



Vanteriors

The Leader in Work Vehicle Modifications

72

1093 Lorimar Drive, Mississauga, ON L5S 1M5 Tel: (905) 565-0540 or (800) 668-7942 Fax: (905) 565-0545

STEP LADDER GUIDE ASSY VR3125, VR3126, VR3127 & VR3128 Assembly & Installation Procedure

Tools Required

5/8" Open end wrench (2), 9/16" open end wrench

General Instructions

The quantity of each part is shown under the part number for the ladder rack ordered. Unpack the box of ladder rack parts and check the contents against the list of materials shown.
Please notify us immediately if anything is missing.

LIST OF COMPONENTS

	PART	DESCRIPTION	QTY
①	VR0012	STRAP STEP LADDER HOLDDOWN	1
②		GUIDE STEP CTR RAIL (VR3360 - 5', VR3361- 6', VR2044-7' & VR2040 - 8')	1
③		GUIDE STEP LADDER (VR3350 - 5', VR2035- 6', VR2043-7' & VR2039 - 8')	2
④	VR2269	STEP LADDER GUIDE EXT. CLAMP	1
⑤	VR3302	ADJUSTABLE STOP POST	1
⑥	VR2174	STIFFENER STAINLESS STEEL	1

LIST OF HARDWARE (VR2065)

PART	DESCRIPTION	QTY
VR2156	NUT 1/4-20 Lock Nylon Ins. S. STL	1
VR2158	BOLT 1/4-20x3/4" TH SOC. S.S.	1
VR2159	WASHER 1/4" S. STL.	2
VR2161	BOLT 3/8-16x1-1/4" Car.GR5 S. STL	8
VR2163	NUT 3/8-16 Hex Flanged S. STL	8
VR2165	WASHER 7/16 CAE S. STL	8



F

BOLT 3/8-16x1-1/4" Car.GR5 S. STL
NUT 3/8-16 Hex Flanged S. STL
WASHER 7/16 CAE S. STL



G

BOLT 1/4-20x3/4" Rd. Hd. S.S.
2 WASHERS 1/4" S. STL
NUT 1/4-20 Lock Nylon Ins. S. STL

**DO NOT EXCEED 20 FT/LBS TORQUE
WHEN TIGHTENING 3/8-16 HARDWARE**

Assembly

Step 1: Pre-assemble holddown strap ① to outer Ladder Step Guide ③ using fas. group **G** (see fig.1). Buckle towards the top so it can be placed over ladder then tightened by pulling down on the strap once it is in the buckle.

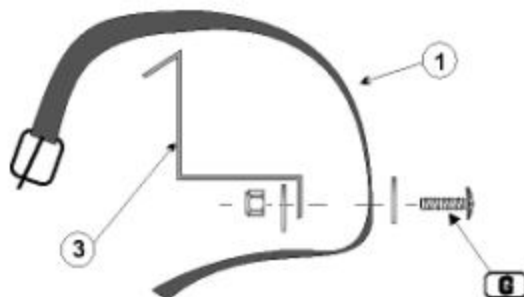

Fig. 1



Vanteriors

The Leader in Work Vehicle Modifications

1093 Lorimar Drive, Mississauga, ON L5S 1M5 Tel: (905) 565-0540 or (800) 668-7942 Fax: (905) 565-0545

STEP LADDER GUIDE ASSY

VR3125, VR3126, VR3127 & VR3128

Assembly & Installation Procedure

Step 2: Pre-assemble adjustable stop post (5) and extended clamp bracket (4) using fas. group (F) (fig.2).

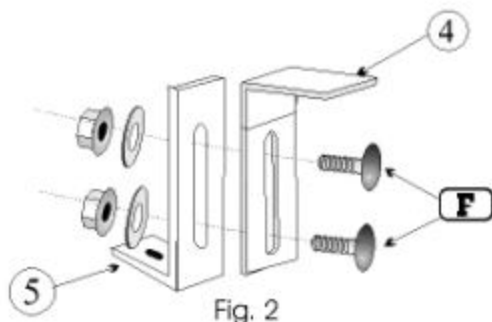

Step 3: Install outer Ladder Step guide with the Holddown Strap attached (Fig.1) to Cross Supports using fas. Group (F) See Fig. 4

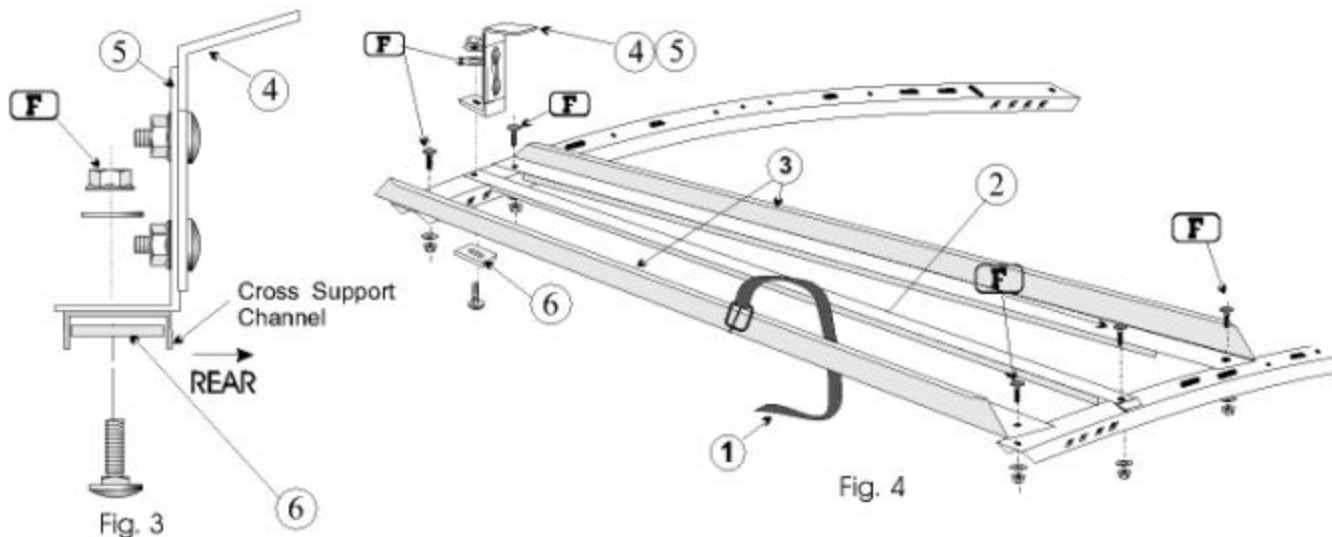

Step 4: Attach Guide Step Rail (2) and pre-assembled (5)(4) unit between the nibs on the top of the forward Cross Support Channel with the extended clamp bracket facing toward the rear Cross Support and Stiffener (6) underneath Support Channel as shown in Fig.3, 4 using fas. Group (F)

Step 5: Install inner ladder step guide (3) to cross support using fas.gr. (F). The rear of the inner ladder step guide is to be attached to one of the slotted holes in the rear cross support, determined by the customer's step ladder's width using fas. group (F) (Fig.4).

Step 6: Lower extended clamp bracket (4) to trap the top of the platform on the step ladder used.