

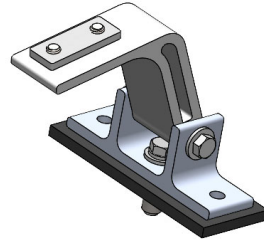

## Mounting Bracket Kit, 2-Pack, White, Transit Connect

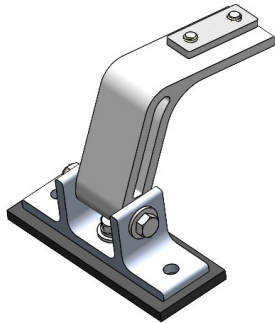

PRODUCT WEIGHT  
**1.6 LBS**

HEIGHT OFF ROOF  
**SEE TABLE BELOW**

CAPACITY  
**REFER TO OEM'S  
RECOMMENDED LOAD  
RATING**  
COLOR

**WHITE**

CATALOG NUMBER

**TCMBK2W**

### PRODUCT FEATURES

**Ford Transit Connect aluminum mounting bracket kit for the PROFILE™ HD Utility Racks to add additional crossbows to 2-Bar rack. Mounting kit works for both 105" and 120" wheelbase vehicles. Can be mounted to any OEM mounting locations to best fit customer's product.**

**Does not work with grip lock or drop down style racks.**

**SEE PAGE 2 FOR APPLICATION NOTES AND ACCESSORIES, OTHER PRODUCTS THAT WORK WITH THIS UNIT.**

### PAGE 1 of 2

The information contained in this document is the sole property of ADRIAN STEEL COMPANY. ADRIAN STEEL COMPANY retains the right to modify and/or change the product of its design at any time without prior notification.



**CATALOG NUMBER TCMBK2W**

**PRODUCT APPLICATION**

**This product is designed to be installed on Ford Transit Connect vans.**

**ACCESSORIES THAT WILL WORK WITH THIS PRODUCT**

CATALOG NUMBER	DESCRIPTION	CATALOG NUMBER	DESCRIPTION
TCMBK4W	Mounting Bracket Kit, 4-Pack, White, Transit Connect	4UPK4B	4" Upright Kit, 4-Pack, Black
2BARCW	2-Crossbar Kit, 58", White, Minivan	4UPK2B	4" Upright Kit, 2-Pack, Black
1BARCW	Single Crossbar Kit, 58", White, Minivan	6UPK4B	6" Upright Kit, 4-Pack, Black
70-1NGLR	4" End Cap for PVC Conduit	6UPK2B	6" Upright Kit, 2-Pack, Black
70-2NGLR	6" End Cap for PVC Conduit	9UPK4B	9" Upright Kit, 4-Pack, Black
		9UPK2B	9" Upright Kit, 2-Pack, Black
		RSK1B	Single Ratchet Upright Kit, 9"
		ULSKB	Single Ladder Stop Kit

**LADDER RACK HEIGHTS MEASURED FROM ROOF OF VEHICLE**

CONFIGURATION	RACK HEIGHT
Base Rack	4.8"
Base + Ladder Stop	10.3"
Base + 4" Uprights	8.3"
Base + 6" Uprights	10.3"
Base + 9"/Ratchet Uprights	13.3"
Base + 4" PVC Conduit Kit	9.2"
Base + 6" PVC Conduit Kit	11.2"
Base + Aluminum Box Conduit Kit	11.3"

INSTR. NUMBER : <b>64473</b>	PG: <b>1</b>	REV: <b>E</b>	ITEM NO.	PART NUMBER	DESCRIPTION	TCMBK4W	TCMBK2W
PART NUMBER : <b>TCMBK</b>			1	68202-W	PROFILE, MOUNTING ARM, W	4	2
			2	63852-W	UTILITY, MOUNTING BRKT, W	4	2
PART DESC. : TC MOUNTING BRKT KIT			3	47106	GASKET, FOOT, MR TRANS L/R	4	2
			4	64930	UTILITY, TRANS CON SPACER	2	-

**NOTE: THIS INSTRUCTION IS VALID FOR THE FOLLOWING KITS:**

**-PART NUMBERS WITH "-W" SUFFIX ARE PAINTED WHITE  
-FOR BLACK MOUNTING KITS, REPLACE "-W" PARTS WITH "-B" PARTS**

- TCMBK4W
- TCMBK2W
- TCMBK4B
- TCMBK2B

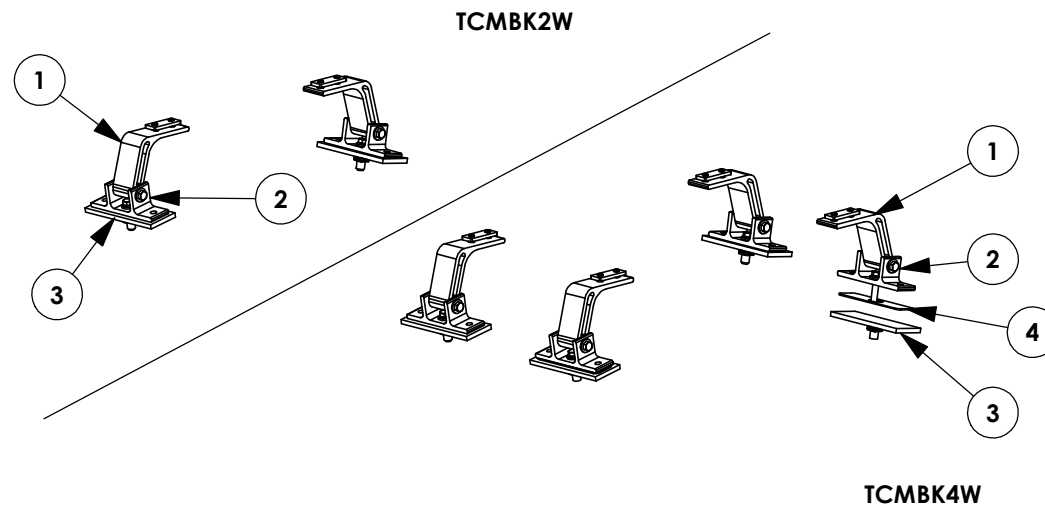

**GET TO KNOW THE VEHICLE** - AT THE BEGINNING OF ANY INSTALLATION, CHECK THE LOCATION OF THE FUEL TANK, FUEL LINES, BRAKE LINES, HIGH VOLTAGE BATTERIES AND WIRING HARNESSSES TO AVOID INJURY OR PROPERTY DAMAGE FROM TOOL CONTACT.

**SEAL ALL EXTERIOR HOLES** - ALL INSTALLATION HOLES SHOULD BE SEALED WITH BUTYL TAPE OR SILICON TO PREVENT WATER AND EXHAUST GASES FROM ENTERING THE VEHICLE.

**CONTROL DRILL DEPTH** - TO AVOID DAMAGE TO THE VEHICLE, USE A DRILL STOP OR CLEARED STEP BIT WHEN DRILLING INSTALLATION HOLES.

**ALWAYS ADD PRIMER** - WHEN ADDING INSTALLATION HOLES BE SURE TO USE A SELF-ETCHING PRIMER TO PREVENT CORROSION, FASTENER FAILURE AND INJURY.

**MOUNTING POINTS MUST HAVE METAL-TO-METAL CONTACT** - USE PROVIDED MOUNTING SPACERS TO ACCOMMODATE FOR VEHICLE FEATURES, CARPET OR SUBFLOORS.

**PROVIDE CLEARANCE FOR SPACERS** - IF THE INSTALLATION VEHICLE CONTAINS A CARPET OR SUBFLOOR, USE A 1-3/16" DIAMETER CARPET CUTTER (P/N: 31183-0) AT ALL MOUNTING LOCATIONS TO OPEN UP ROOM FOR SPACERS.

**CHECK SPACER ORIENTATION** - BE SURE THAT THE INDENT IN THE SPACER COVERS THE PLUSNUT HEAD; THIS ENSURES THE MOST METAL-TO-METAL CONTACT AND REDUCES VIBRATION.

**PLUSNUT INSTALLATION** - A PLUSNUT GUN IS RECOMMENDED FOR PLUSNUT INSTALLATION FOR ITS PRODUCTION SPEED. HOWEVER, A PLUSNUT SETTING TOOL CAN ALSO BE USED (P/N: 22200-0).

**THRU-BOLT CLEARANCE** - WHEN USING A THRU-BOLT AT ANY MOUNTING LOCATION, BE SURE THAT YOUR HOLE HAS 1/16" CLEARANCE.

**FASTENERS USED**

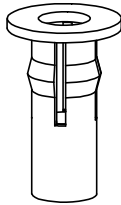

**FAS0091**  
5/16-18 PB  
PLUSNUT  
QTY: 4

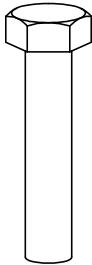

**FAS0242**  
5/16-18X1.5 SS  
HH SCREW  
QTY: 4



**FAS0858**  
5/16-18 X .625 SS  
FHH SCREW  
QTY: 8



**FAS0243**  
5/16-18X2.5 SS  
HH SCREW  
QTY: 4



**FAS0857**  
5/16 SS, CS  
LCK EXT WASHER  
QTY:8



**FAS0861**  
5/16-18 SS  
NLK HEX NUT  
QTY: 4



**FAS0552**  
5/16 SS  
FLAT WASHER  
QTY: 8



**FAS0588**  
5/16 SS  
SPLIT WASHER  
QTY: 4

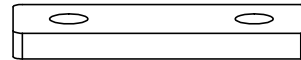

**68042**  
PROFILE FOOT  
MTG PLATE  
QTY: 4

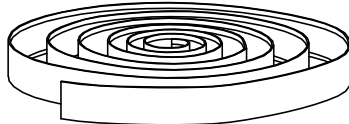

**05586-0**  
BUTYL TAPE  
T224 1FT ROLL  
QTY: 1

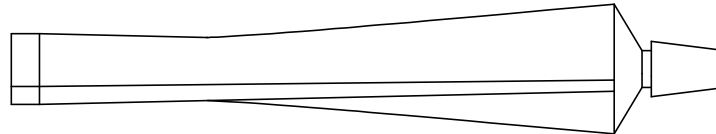

**26618-0**  
SILICONE  
1 OZ TUBE  
QTY: 1

***INTENTIONALLY LEFT BLANK***

**STEP 1 - ASSEMBLE MOUNTING ARMS TO CROSSBOW**

**STEP 1.1:**  
**LOOSELY INSTALL**  
**(2) FAS0857, (2)**  
**FAS0858 & 68042**  
**(2 PLACES PER**  
**CROSSBOW)**  
**3/16" ALLEN**

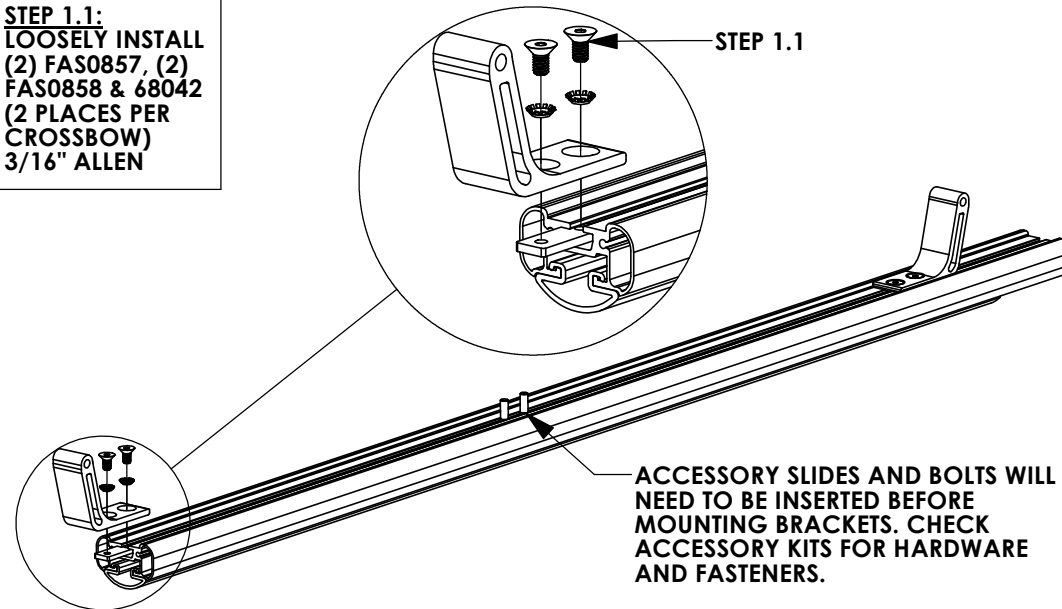

**STEP 2 - INSTALL MOUNTING BRACKETS TO VEHICLE ROOF**

**STEP 2.1:**  
**OPEN UP OEM HOLE WITH 1/2"**  
**DRILL BIT. USE A DRILL STOP TO**  
**PREVENT DAMAGE TO**  
**MATERIAL UNDER HOLE**

**STEP 2.2:**  
**FAS0242, FAS0588, FAS0552,**  
**FAS091**  
**(2 PLACES PER CROSSBOW)**  
**1/2" SOCKET**  
**5/16"-18 PLUSNUT GUN**

**STEP 2.3:**  
**64930 SPACER ONLY USED ON**  
**REAR CROSSBOW**

**POKE FASTENERS THRU FOAM PAD**

**APPLY SILICONE AND BUTLY TAP**  
**TO BOLT BEFORE TIGHTENING**

**CROSSBOW POSITIONING NOTES:**

REAR CROSSBOW - REAR OEM MOUNTING LOCATION

FRONT CROSSBOW - POSITION TO BEST FIT END USER'S PRODUCT

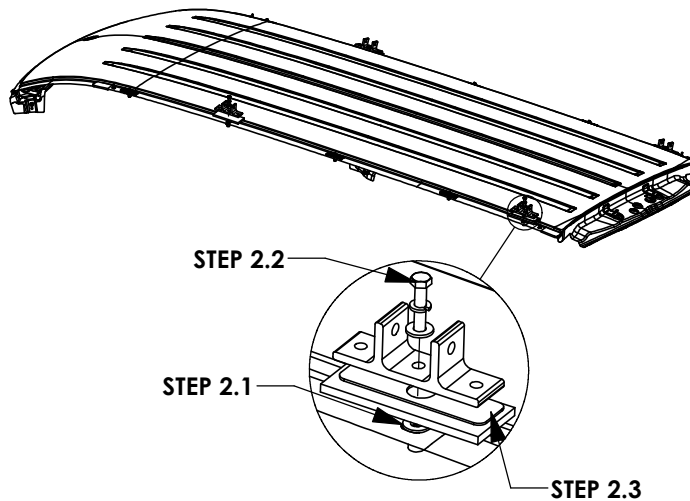

**STEP 3 - ATTACH CROSSBOW ASSEMBLY TO MOUNTING BRACKETS**

**STEP 3.1:**  
FAS0243, FAS0522, FAS0861  
(2 PLACES PER CROSSBOW)  
1/2" SOCKET  
1/2" WRENCH

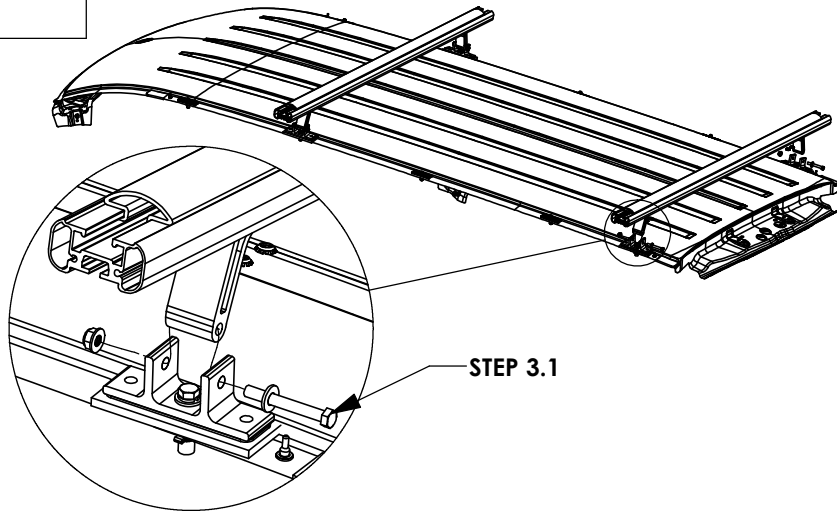

**STEP 4 - SECURE CROSSBOW**

**STEP 4.1:**  
CENTER CROSSBOW AND  
SECURE MOUNTING  
BRACKETS  
(4 PLACES PER  
CROSSBOW)  
3/16" ALLEN

