

# PURCHASED COMPONENT KEY FEATURES

## DESCRIPTION OF REQUIREMENTS

DIMENSIONAL REQUIREMENTS (AS SHOWN ON DRAWING)

N/A

LOAD/RATING REQUIREMENT

N/A

MATERIAL REQUIREMENT

N/A

PACKAGING REQUIREMENT

N/A

OTHER REQUIREMENTS

N/A

## INSTALLATION FASTENERS:

- (2) FAS0521 1/4-20 X 1-3/4 HX.HD.SCW G5
- (4) FAS0522 1/4-20 X 2-3/4 HX.HD.SCW G5
- (4) FAS0125 1/4-20 ELASTIC LOCKNUT SS
- (4) FAS0067 1/4 PLN FLAT WASHER DC

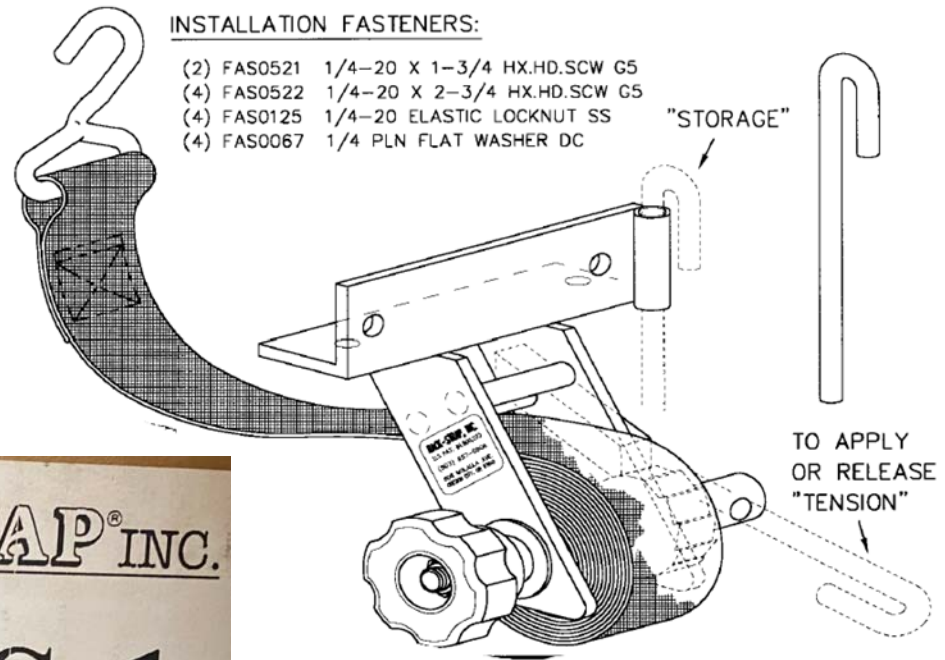

**RACK-STRAP<sup>®</sup> INC.**



**RS-1**

2750 Industrial Ave, Hubbard, OR 97032  
 Phone: (503) 982-1920 Fax: (503) 982-7022  
 Toll Free: (800) 841-5790 www.RackStrap.com

THIS DRAWING IS THE PROPERTY OF ADRIAN STEEL COMPANY AND IS NOT TO BE USED IN ANY MANNER DETRIMENTAL TO THE INTERESTS OF ADRIAN STEEL COMPANY

PRINTED DOCUMENT IS UNCONTROLLED

Sheet 1 of 1

### TOLERANCES & INSPECTION

UNLESS OTHERWISE SPECIFIED  
 ALL BEND ANGLES ARE 90 DEGREES  
 ALL DIMENSIONS ARE IN INCHES.  
 REFERENCE DIMENSIONS (X.XXX)  
 DO NOT REQUIRE INSPECTION

FEATURES	HOLES/SLOTS	ANGLES
0.0 ± .125	0.0 ± .062	0° ± 2°
0.00 ± .062	0.00 ± .031	0.0° ± 1°
0.000 ± .031	0.000 ± .015	

Material Thickness: per ASTM Std.  
 Weld Callouts per AWS

### RELEASE & REVISIONS

INITIAL ECN: **6071**  
 CURRENT ECN: **23488**  
 ECN DESCRIPTION:  
**UPDATED PRINT**  
 REVISED BY: **DTT**

## PURCHASED COMPONENT

REFERENCED SUPPLIER AND/OR MANUFACTURER  
**RACK-STRAP, INC.**  
 REFERENCED SUPPLIER AND/OR MANUFACTURER PART NUMBER  
**RS-1**  
 COLOR (ONLY LIST IF COLOR SPECIFIC)  
 COMODITY ITEM (Y/N) (YES = ALL DIMENSIONS AND NOTES ARE REFERENCE)  
 (NOTE: DIMENSIONS AND FEATURES MAY VARY FOR A COMODITY ITEM.)  
**YES**

### PART / PRODUCT IDENTIFICATION

 <b>ADRIAN STEEL<sup>®</sup></b>		ADRIAN STEEL COMPANY 906 JAMES STREET, ADRIAN, MI 49221	REVISION LEVEL <b>B</b>
MAT'L USED:	<b>PURCHASED</b>	DESIGNED BY:	<b>THOMPSON</b>
DESCRIPTION: <b>RACHET STRAP, SQ. TUBE</b>			
WEIGHT (Lbs.):	<b>2.96</b>	SEGMENT CODE:	<b>VLR</b>
		PART NUMBER:	<b>RS4</b>

**INSTALLATION FASTENERS:**

- (2) FAS0521 1/4-20 X 1-3/4 HX.HD.SCW G5
- (4) FAS0522 1/4-20 X 2-3/4 HX.HD.SCW G5
- (4) FAS0125 1/4-20 ELASTIC LOCKNUT SS
- (4) FAS0067 1/4 PLN FLAT WASHER DC

**SOURCE:**

RACK-STRAP, INC.  
 808 MOLALLA AVE.  
 OREGON CITY, OR 97045  
 (503) 657-0806

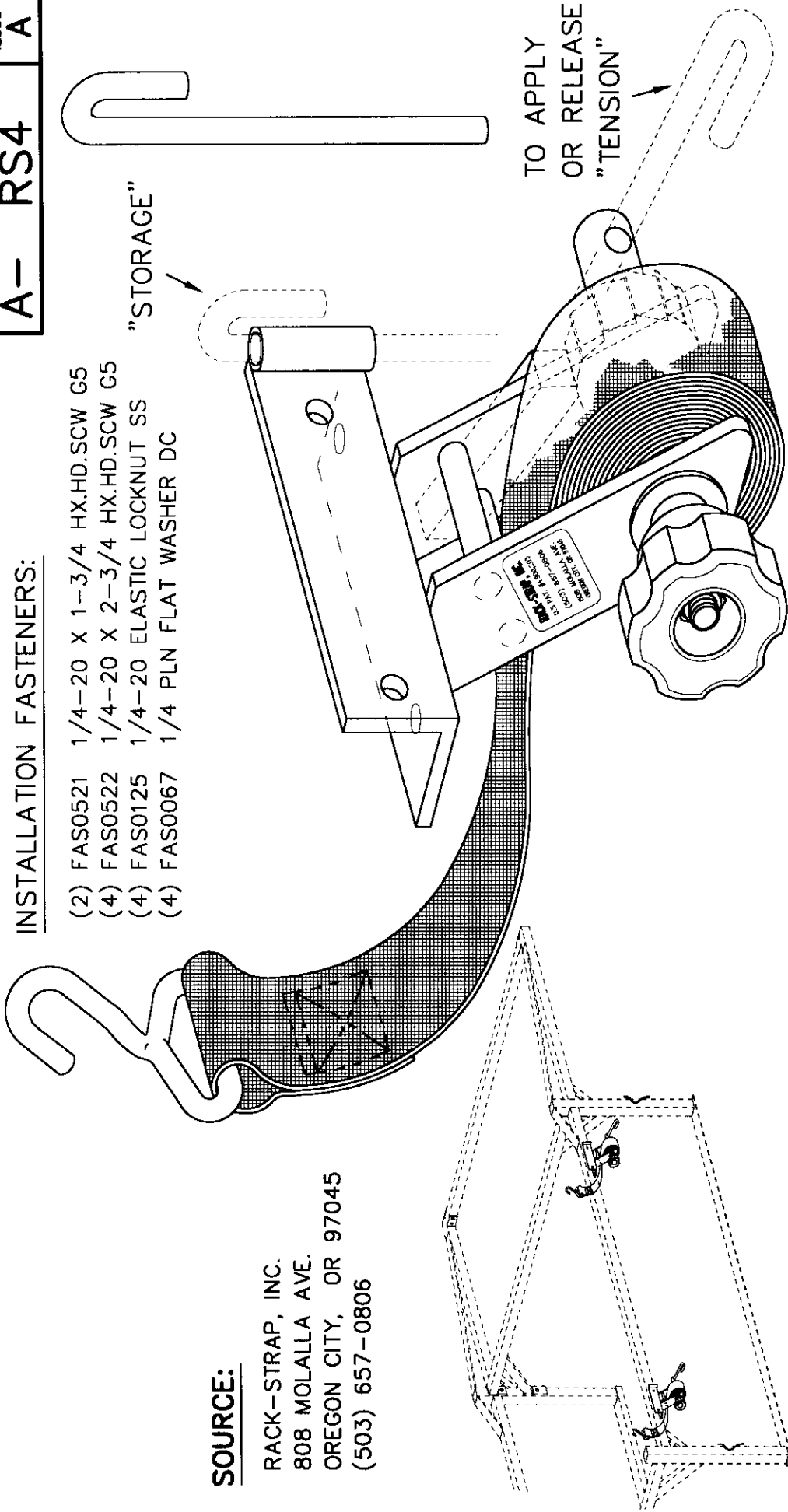

MATERIAL: SEE SOURCE ABOVE WT. 2.97 #	SYMBOL	CHANGE
	EN	6071 6/27/02 RELEASED
FINISH:	ADRIAN STEEL CO. ADRIAN MICHIGAN	
NOTES:	REFERENCE: REF 19750	ISSUE A
FINISHED WT.	BY MAE DATE 6/27/02	NAME
	OR SCALE 1/2	RACK STRAP (RS4)
		A- RS4