



**ADRIAN STEEL®**  
VAN AND PICKUP EQUIPMENT

# RS-3 RATCHET STRAP

## RS-3 RATCHET STRAP INSTALLATION INSTRUCTIONS “LOAD RUNNER LADDER RACKS”

P.N.: 33159-0

ISSUE: B

CHK.BY: \_\_\_\_\_

REV.BY:

DATE: 11/21/12 DWG.BY: DCS

ECN-15217

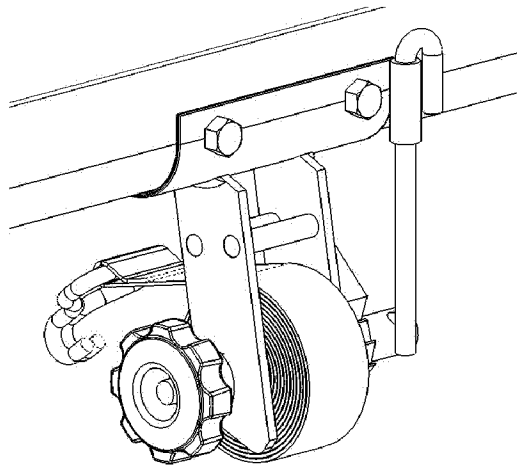
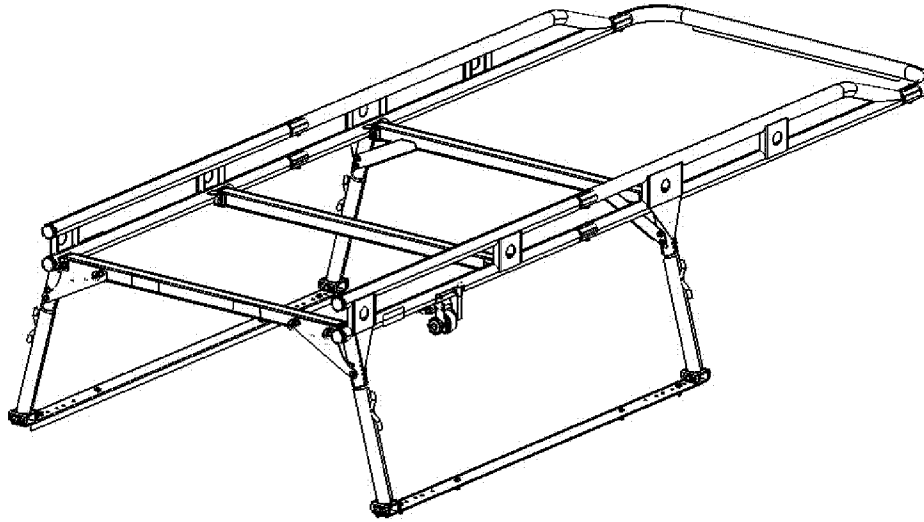



**ADRIAN STEEL®**

VAN AND PICKUP EQUIPMENT

# RS-3 RATCHET STRAP

## BEFORE YOU START!

IMPORTANT INSTALLATION STEPS ARE DENOTED USING A STOP SIGN. THESE STEPS MUST BE PERFORMED AS SPECIFIED IN ORDER TO ENSURE A PROPER INSTALLATION AND MUST BE FOLLOWED IN ORDER TO MAINTAIN YOUR PRODUCT WARRANTY!



CRITICAL INFORMATION PERTAINING TO USER AND/OR VEHICLE SAFETY IS DENOTED USING A CAUTION SIGN. SAFETY ITEMS MUST BE STRICTLY ADHERED TO IN ORDER TO ENSURE A SAFE WORKING ENVIROMENT!



YOU WILL NEED THE FOLLOWING TOOLS IN ORDER TO COMPLETE THIS JOB.

3/8" COMBINATION END WRENCH, RATCHET with 3/8" SOCKET,  
TORQUE WRENCH  
DRILL MOTOR, 13/32" DRILL BIT, PERMANENT MARKER PEN,  
CENTER PUNCH, SAFTEY GLASSES

ALL FASTENERS USED IN THE ASSEMBLY AND INSTALLATION OF THIS PRODUCT SHOULD BE TIGHTENED TO THE SPECIFIED TORQUE AS LISTED WITH EACH FASTENER CALLOUT BOX.



THE USE OF AIR OR ELECTRIC IMPACT TOOLS FOR THE ASSEMBLY OF FASTENERS IS NOT RECOMMENDED AND COULD CAUSE FASTENER FAILURE!



## WARNING



THE USE OF DRILLS WITH INTEGRAL DRILL STOPS ALONG WITH PROPER INSPECTION FOR GAS TANK, GAS LINES, BRAKE LINES AND ELECTRICAL LINES PRIOR TO DRILLING ANY MOUNTING HOLES IS STRONGLY RECOMMENDED TO ENSURE THAT VEHICLE DAMAGE IS AVOIDED!



THE USE OF NON-STANDARD FASTENERS AND/OR DEVIATING FROM THE FASTENERS SPECIFIED IN THE INSTRUCTION (S) MAY VOID YOUR PRODUCT WARRANTY!

ALL DRILLED HOLES IN THE VEHICLE SHOULD HAVE THE RAW METAL EDGES SEALED WITH A SELF-ETCHING PRIMER TO RESIST CORROSION AND POTENTIAL FASTENER POINT FAILURE!

ADRIAN STEEL COMPANY • 906 JAMES ST. • ADRIAN, MI. 49221 • (517) 265-6194



# RS-3 RATCHET STRAP



## STEP – 01

### SELECT RATCHET STRAP MOUNTING LOCATION

Position the RACK-STRAP on the round tubular lower truss rail as illustrated on cover page. Manufacturer suggests RACK-STRAPS should be located on each side of vehicle rack. Spacing the RACK-STRAPS evenly, front-center-back, will secure your load more evenly.

## STEP – 02

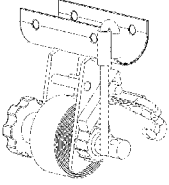
### MOUNTING RATCHET STRAP ON LADDER RACK

 <p><b>RS-3 RATCHET STRAP</b></p>	 <p><b>FAS0620 BOLT, HEX HD, 3/8-16UNC X 3.00" GRADE 8, (2) REQ'D</b></p>	 <p><b>FAS0110 NUT, NYLON LOCK, 3/8-16UNC, SS, (2) REQ'D 30 FT-LBS TORQUE</b></p>
--	--	--

Place the Ratchet Strap in position and mark all (4) mounting holes for drilling. Set the Ratchet Strap aside and center punch all (4) marked mounting hole locations. Drill a 13/32" diameter through hole at each center punch location, de-burr holes as required.

Reposition the Ratchet Strap and secure in place with fasteners as shown in illustration below, tighten the fasteners to 30 FT-LBS

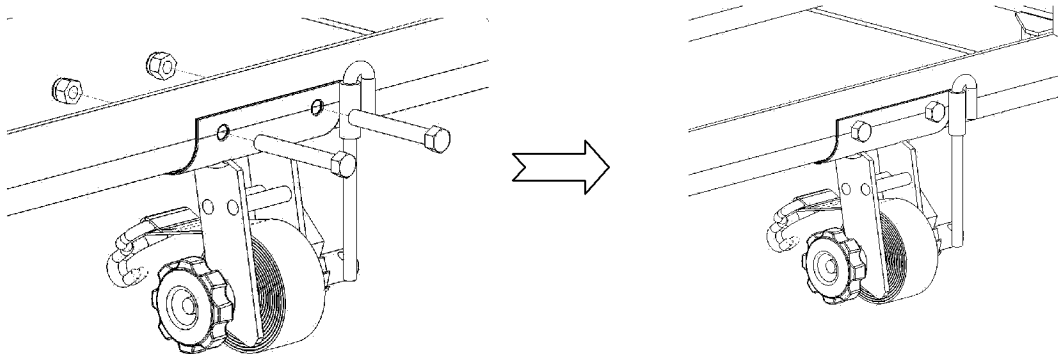

**DOUBLE-CHECK ALL FASTENER LOCATIONS TO BE SURE THAT ALL FASTENERS ARE TIGHTENED TO SPECIFICATIONS!**



**YOUR INSTALLATION IS NOW COMPLETE! STOW THIS COPY IN THE VEHICLE FOR FUTURE REFERANCE!**