

<i>INSTR. NUMBER</i> : <b>64955</b>	<i>PG:</i> <b>1</b>	<i>REV:</i> <b>B</b>	<i>ITEM NO.</i>	<i>PART NUMBER</i>	<i>DESCRIPTION</i>	
			1	64174	REAR ROLLER,BAR ASSM,62"	1
<i>PART NUMBER</i> : <b>RRBPMW</b>			2	64161-W	REAR ROLLER,DS WELD,PM,W	1
<i>PART DESC.</i> : UTILITY,REAR ROLLER,PM,W			3	64162-W	REAR ROLLER,PS WELD,PM,W	1

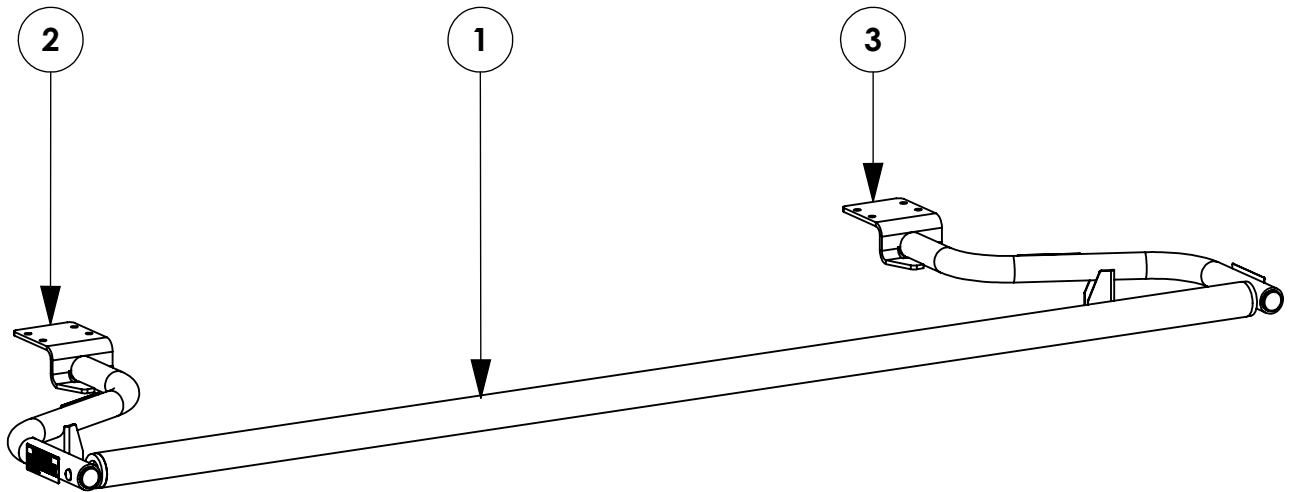

**GET TO KNOW THE VEHICLE** - AT THE BEGINNING OF ANY INSTALLATION, CHECK THE LOCATION OF THE FUEL TANK, FUEL LINES, BRAKE LINES, HIGH VOLTAGE BATTERIES AND WIRING HARNESES TO AVOID INJURY OR PROPERTY DAMAGE FROM TOOL CONTACT.

**SEAL ALL EXTERIOR HOLES** - ALL INSTALLATION HOLES SHOULD BE SEALED WITH BUTYL TAPE OR SILICON TO PREVENT WATER AND EXHAUST GASES FROM ENTERING THE VEHICLE.

**CONTROL DRILL DEPTH** - TO AVOID DAMAGE TO THE VEHICLE, USE A DRILL STOP OR CLEARED STEP BIT WHEN DRILLING INSTALLATION HOLES.

**ALWAYS ADD PRIMER** - WHEN ADDING INSTALLATION HOLES BE SURE TO USE A SELF-ETCHING PRIMER TO PREVENT CORROSION, FASTENER FAILURE AND INJURY.

**MOUNTING POINTS MUST HAVE METAL-TO-METAL CONTACT** - USE PROVIDED MOUNTING SPACERS TO ACCOMMODATE FOR VEHICLE FEATURES, CARPET OR SUBFLOORS.

**PROVIDE CLEARANCE FOR SPACERS** - IF THE INSTALLATION VEHICLE CONTAINS A CARPET OR SUBFLOOR, USE A 1-3/16" DIAMETER CARPET CUTTER (P/N: 31183-0) AT ALL MOUNTING LOCATIONS TO OPEN UP ROOM FOR SPACERS.

**CHECK SPACER ORIENTATION** - BE SURE THAT THE INDENT IN THE SPACER COVERS THE PLUSNUT HEAD; THIS ENSURES THE MOST METAL-TO-METAL CONTACT AND REDUCES VIBRATION.

**PLUSNUT INSTALLATION** - A PLUSNUT GUN IS RECOMMENDED FOR PLUSNUT INSTALLATION FOR ITS PRODUCTION SPEED. HOWEVER, A PLUSNUT SETTING TOOL CAN ALSO BE USED (P/N: 22200-0).

**THRU-BOLT CLEARANCE** - WHEN USING A THRU-BOLT AT ANY MOUNTING LOCATION, BE SURE THAT YOUR HOLE HAS 1/16" CLEARANCE.

***FASTENERS USED***

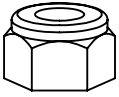

**FAS0248**  
**5/16-18 SS**  
**NLK HEX NUT**  
**QTY: 4**



**FAS0552**  
**5/16 SS**  
**FLAT WASHER**  
**QTY: 4**

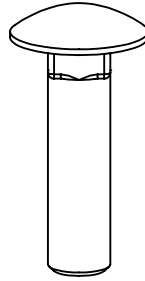

**FAS0812**  
**5/16-18X1.25 SS**  
**CRG BOLT**  
**QTY: 4**

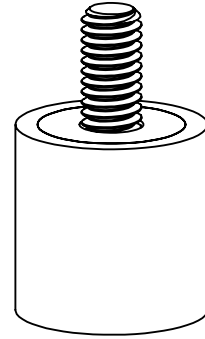

**56098**  
**1 X 1**  
**BUMPER STUD**  
**QTY: 2**

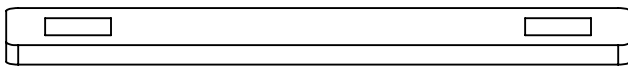

**64830**  
**REAR ROLLER**  
**BOLT PLATE**  
**QTY: 2**

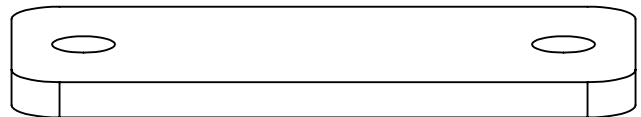

**64831**  
**REAR ROLLER**  
**SPACER**  
**QTY: 2**

**BEGIN ASSEMBLY**

**STEP 1 - ATTACH ROLLER ARMS TO CROSSBOW**

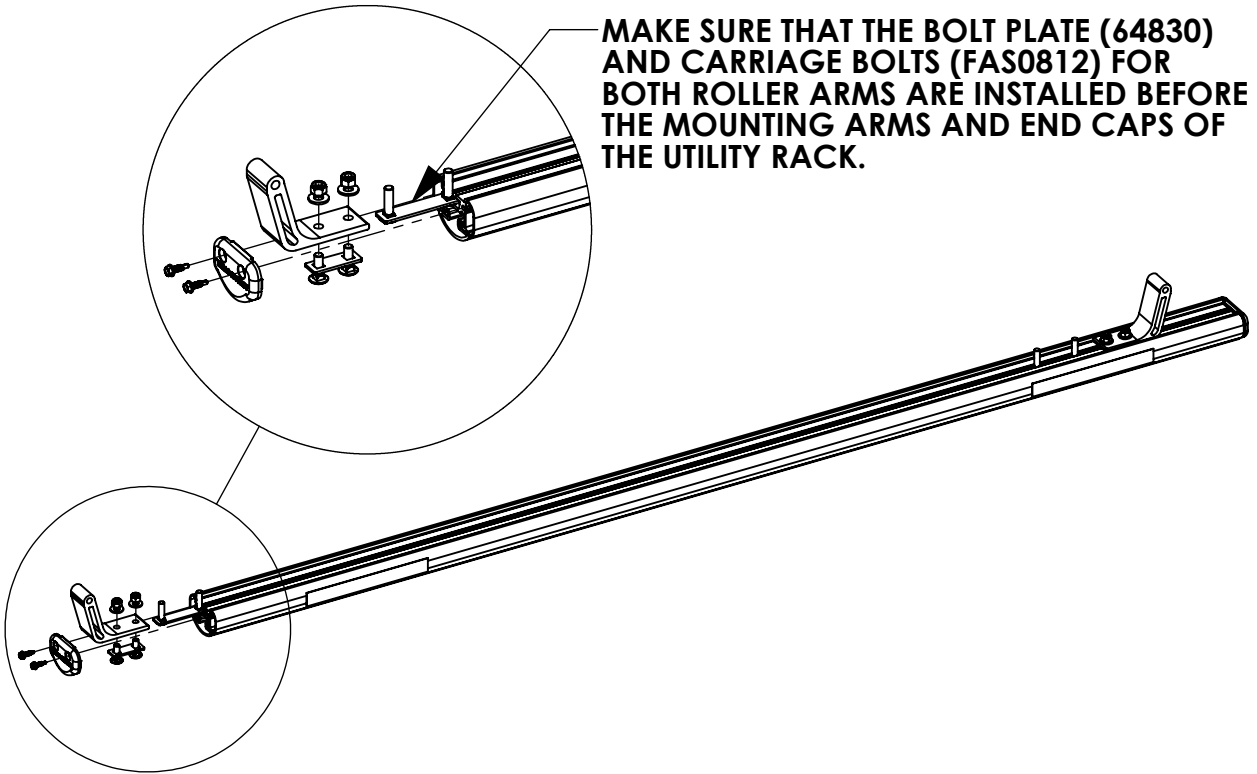

**STEP 2 - ADD ROLLER BAR & SECURE**

ADD 56098 TO EACH ROLLER ARM

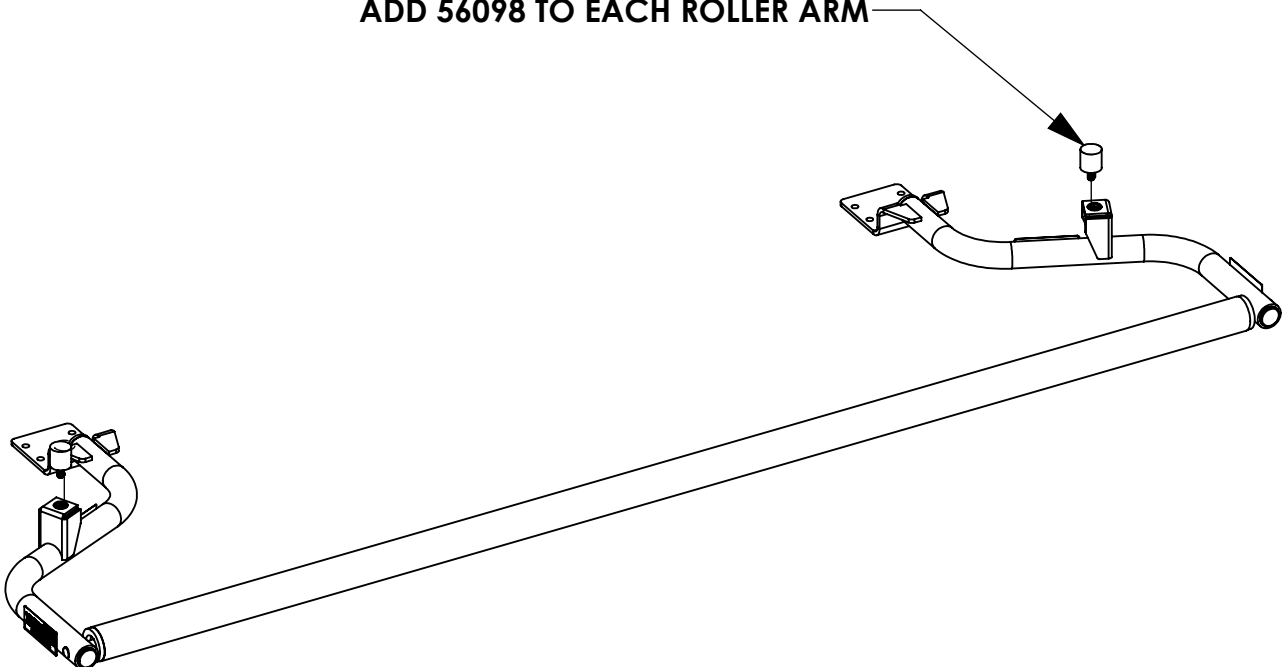

**BEGIN INSTALL**  
**STEP 3 - ATTACH ROLLER ARMS TO CROSSBOW**

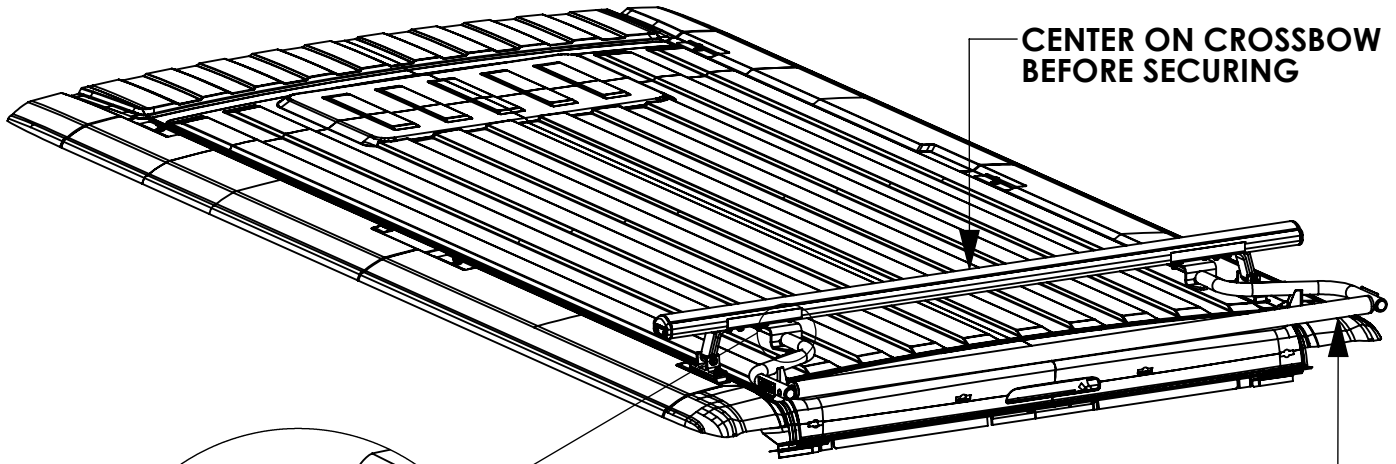

CENTER ON CROSSBOW  
BEFORE SECURING

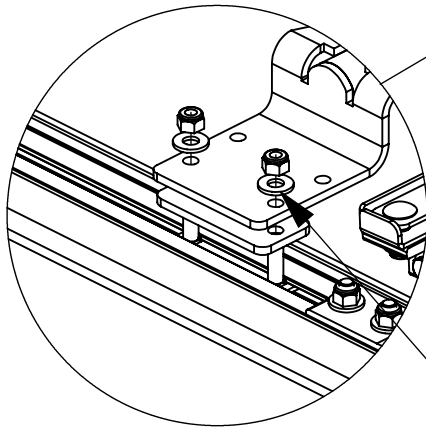

ADD ROLLER BAR  
PRIOR TO INSTALLING  
ARMS

FAS0248, FAS0552  
64831  
(4 PLACES)  
1/2 SOCKET

NOTE: DETAIL VIEW IS  
FROM BOTTOM OF RACK

ENSURE THE RUBBER BUMPERS SIT AS FAR INBOARD IN THE  
VEHICLE ROOF TROUGH BEFORE FULLY TIGHTENING!

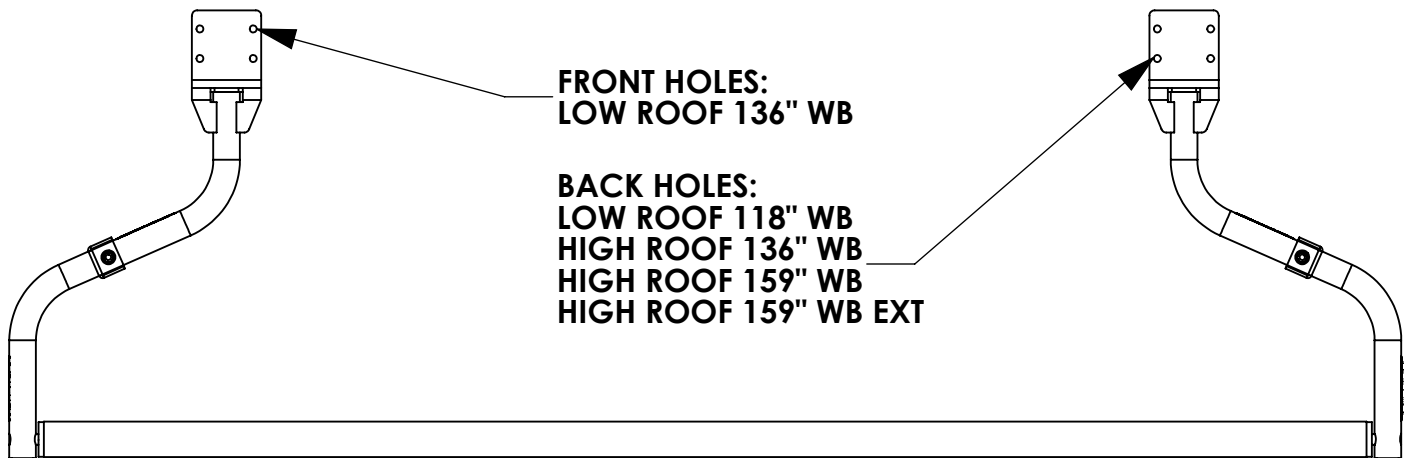

FRONT HOLES:  
LOW ROOF 136" WB

BACK HOLES:  
LOW ROOF 118" WB  
HIGH ROOF 136" WB  
HIGH ROOF 159" WB  
HIGH ROOF 159" WB EXT