



**PRODUCT WEIGHT**  
15 LBS

**WIDTH x DEPTH x HEIGHT**  
71.8" x 31" x 5"

**CAPACITY**  
200 LBS

**COLOR**  
BLACK / WHITE

**CATALOG NUMBER**  
RRBLCV2 -B/-W

**PRODUCT FEATURES**

**REAR ROLLER KIT FOR THE NISSAN NV UTILITY RACK. FOR USE WITH THE 3BNLCV AND 2BNLCV.**

**ALLOWS FOR EASE OF LOADING**

**SEE PAGE 2 FOR APPLICATION NOTES AND ACCESSORIES, OTHER PRODUCTS THAT WORK WITH THIS UNIT.**



**CATALOG NUMBER** RRBLCV2 -B/-W

***PRODUCT APPLICATION***

THIS PRODUCT IS DESIGNED FOR THE NISSIAN NV STD ROOF VAN.  
WILL FIT BOTH AVAILABLE WHEELBASES

***ACCESSORIES THAT WILL WORK WITH THIS PRODUCT***

<b>CATALOG NUMBER</b>	<b>DESCRIPTION</b>
-----------------------	--------------------

***SPECIAL APPLICATION NOTES***

### Introduction / Comments:

This Rear roller is designed to fit in the Nissan 2BARRNV AND 3BARRNV. THIS ONLY FITS THE STANDARD ROOF NV, **DOES NOT FIT ON THE HIGH ROOF VERSION.** THIS WILL NOT WORK WITH PREVIOUSLY MOUNTED 2BNLCV OR 3BNLCV.

**Note:**

It is advised that all fasteners used in this assembly and installation should be checked for tightness at the following intervals: @ 2-weeks and again @ 6-weeks of operation. This preventive maintenance step must be completed to ensure your Rear Roller gives you long service life.

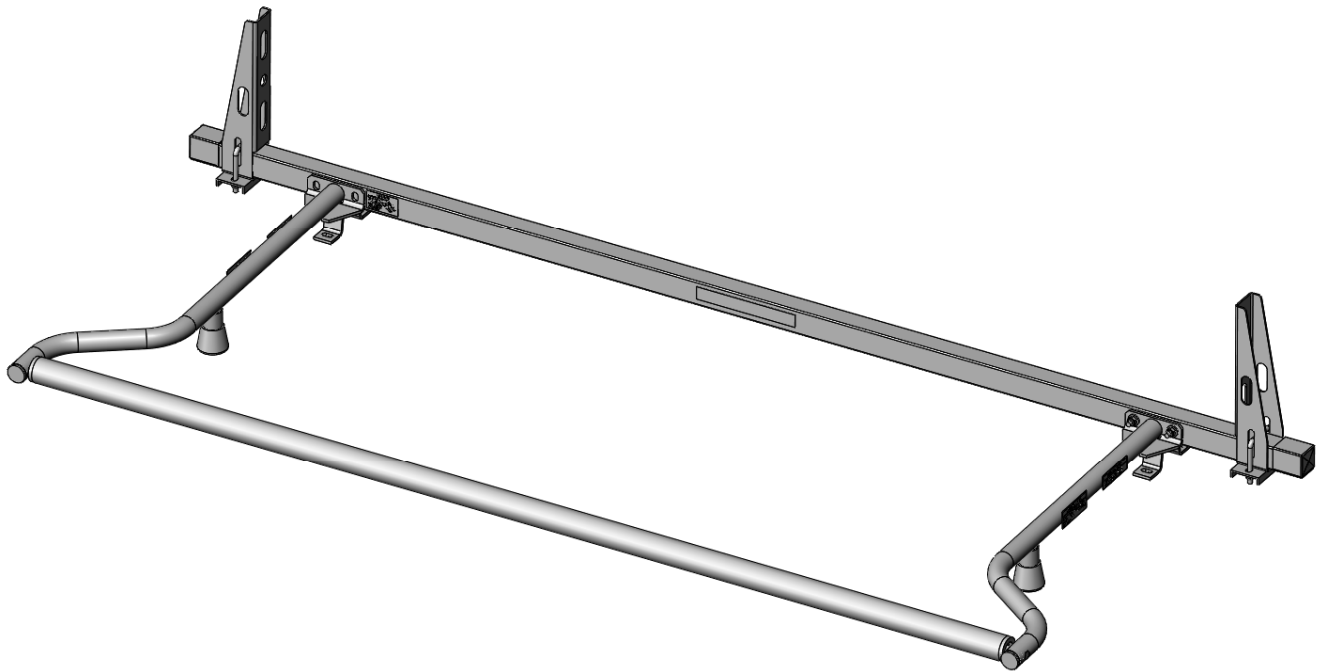

**RRBLCV2-W SHOWN  
ATTACHED TO 43849 FOR REFERENCE**

**RRBLCV2-B and RRBLCV2-W  
Utility Racks for Nissan Std Roof Vans**

## - PRECAUTIONS -





 **CAUTION**   
**THE USE OF AIR IMPACT TOOLS CAN  
OVER-TORQUE FASTENERS AND  
CAUSE FASTENER FAILURE!**



 **CAUTION**   
**ALL INSTALLATION HOLES SHOULD BE SEALED  
WITH SILICON OR BUTYL SEALANT TO PREVENT  
EXHAUST FUMES FROM ENTERING THE VEHICLE!**



 **DANGER**   
**INSPECT FOR FUEL TANK, FUEL LINES, BRAKE LINES, HIGH  
VOLTAGE BATTERIES AND ELECTRICAL LINES PRIOR TO  
DRILLING TO AVOID DAMAGING CRITICAL VEHICLE SYSTEMS  
OR INJURY TO INSTALLER DURING INSTALLATION PROCESS!**



 **CAUTION**   
**TO AVOID DAMAGING THE VEHICLE ALWAYS  
USE DRILL STOPS WHEN DRILLING ANY IN-  
STALLATION HOLES!**



## - IMPORTANT WARRANTY REQUIREMENTS -

1. SUBSTITUTING ADRIAN STEEL SPECIFIED FASTENERS FOR ASSEMBLY AND/OR INSTALLATION WILL VOID YOUR PRODUCT WARRANTY.
2. ALL HOLES DRILLED INTO VEHICLE SHOULD HAVE THE RAW METAL EDGES SEALED WITH A SELF-ETCHING PRIMER TO RESIST CORROSION AND POTENTIAL FASTENER POINT FAILURE.
3. ALL FASTENERS USED IN THE INSTALLATION OF THIS PRODUCT SHOULD BE TIGHTENED TO THE TORQUE(S) SPECIFIED IN THESE INSTRUCTIONS.
4. THESE INSTRUCTIONS SHOULD BE KEPT WITH THE VEHICLE.

### THE BASIC TOOLS NEEDED FOR MOST INSTALLATIONS



DRILL



DRILL BIT WITH  
STOP



RATCHET, SOCKETS  
AND/OR WRENCHES



SCREWDRIVERS



MEASURING TAPE

ADDITIONAL TOOLS MAY BE NEEDED FOR THIS INSTALLATION AND THEY WILL BE IDENTIFIED IN THE STEPS THAT FOLLOW.

If your vehicle contains carpet or a rubber floor mat you will need to prepare the mounting location. Position the product to be installed into the vehicle and once you are satisfied with the mounting locations, mark the mounting locations. Using a 1-3/16" diameter carpet cutter (P/N: 31183-0). Select the appropriate floor spacers as shown in the illustration. Set those aside for use later into the installation process. Using the correct drill bit size for the selected plusnut, drill the mounting holes in the vehicle sheet metal to prepare for installing the plusnuts. If you are thru-bolting at any of the locations simply drill a hole that is 1/16" larger than the bolt size(s) for those locations. Once you have drilled the holes into the vehicle, the raw metal edges should be sealed using a self-etching primer to resist corrosion and potential fastener point failure.

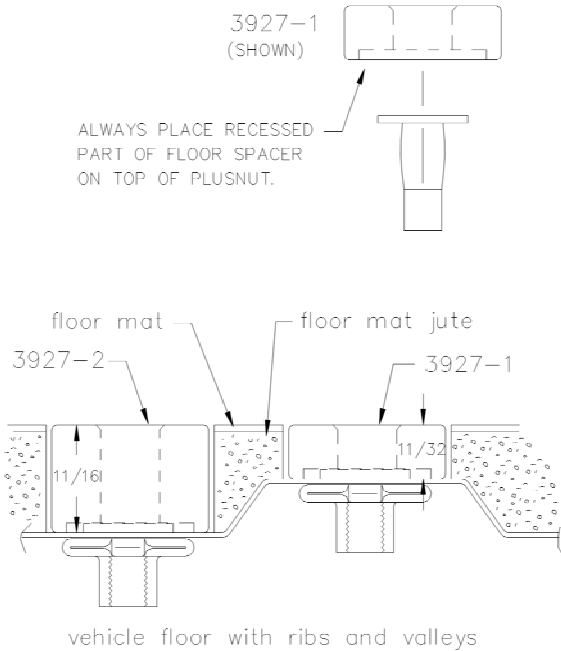

A PLUSNUT (RIVNUT) SETTING TOOL IS REQUIRED FOR PLUSNUT (RIVNUT) INSTALLATION AND IS SUPPLIED WITH THIS KIT. OR USE AN AIR POWERED PLUSNUT SETTING GUN.

1/4-20UNC Plusnut (FAS0052) Use 3/8" dia. drill w/stop  
 FAS0080 SCREW, HXHD, 1/4-20UNCx2.00", G8  
 FAS0067 WASHER, FLAT, 1/4"ID  
 22200-0 PLUSNUT TOOL

5/16-18UNC Plusnut (FAS0091) Use 1/2" dia. drill w/stop  
 FAS0095 SCREW, HXHD, 5/16-18UNCx2.00", G8  
 FAS0086 WASHER, FLAT, 5/16"ID  
 22200-0 PLUSNUT TOOL

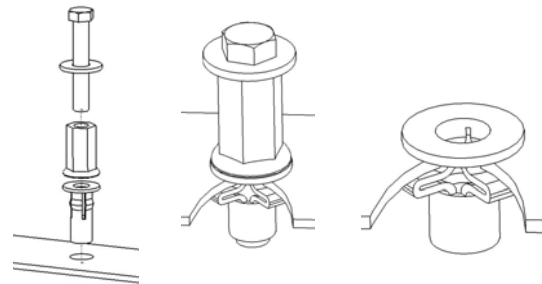





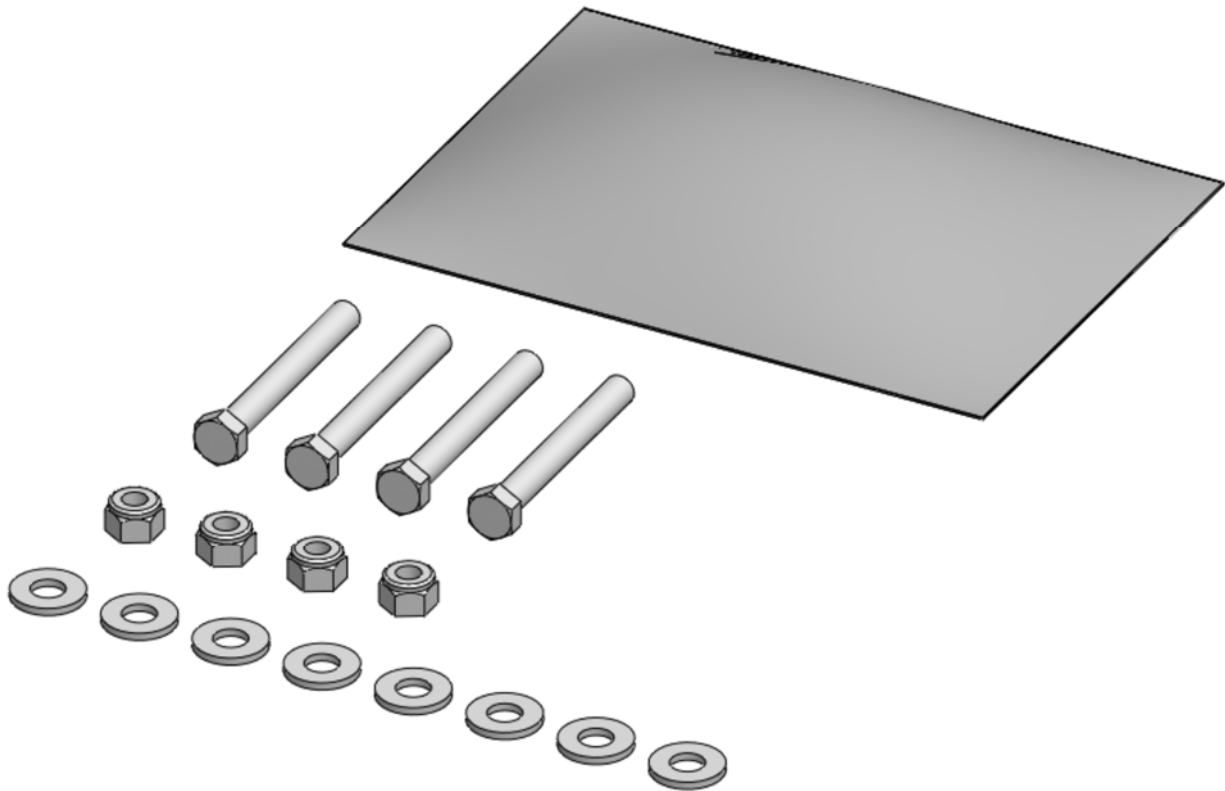

Place barrel of the plusnut body in sheet metal thru hole until flange is flush with sheet metal. Using a 9/16" combination wrench of plusnut tool body and a second hand wrench, ratchet, or air tool, rotate the hex bolt head CW to draw plus nut flanges up (set the plusnut).

**Installation and/or Assembly Fasteners**  
**BAGRRB**

BILL OF MATERIAL AND FASTENER BAG FOR  
BAGRRBDPM

ITEM NO.	PART NUMBER	DESCRIPTION	
1	BAG0507-A	5" x 7" 3MIL AUTOBAG	1
2	FA S0243	Screw, Hex Hd, 5/16-18x2.50 Stainless Steel	4
3	FA S0248	Nut, Nylon Insert Lock, 5/16-18 SST	4
4	FA S0552	Washer, Flat, 5/16, SST	8



<b>PARTS YOU WILL USE FOR</b>  <b>STEP 1</b>	57547-W RLR SPT ARM NV, SS (1) REQ'D	57546-W RLR SPT ARM NV, CS (1) REQ'D		
				
	FAS0243 5/16-18 X 2.50 HEX SCREW (2) REQ'D	FAS0552 5/16" FLAT WASHER (4) REQ'D	FAS0248 5/16-18 HEX NUT (2) REQ'D	
				

## Instructions for Step 1

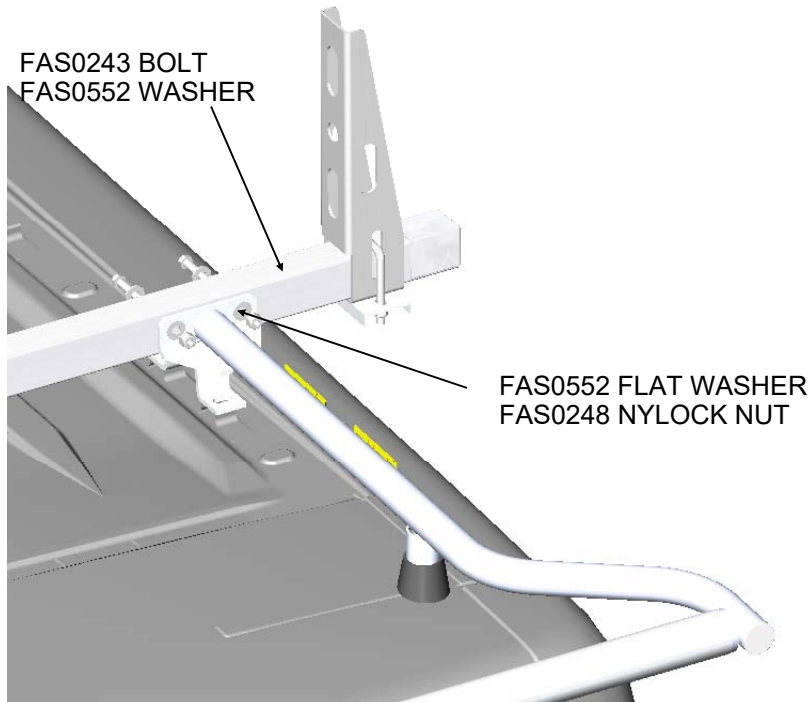

CURB SIDE SHOWN  
57546-W/B

ASSEMBLE ONE ROLLER ARM ASM TO REAR CROSSBAR AS SHOWN. CLEAN ROOF AREA WHERE LOWER LEG OF ROLLER ARM WILL CONTACT. PEEL BACKING FROM TAPE ON UNDER-SIDE OF ROLLER ARM LEG SO IT WILL STICK TO ROOF. TORQUE FASTENERS TO 12 FT LBS.

<b>PARTS YOU WILL USE FOR</b>          <b>STEP 2</b>	43619 REAR ROLLER ASM (1) REQ'D			
				

## Instructions for Step 2

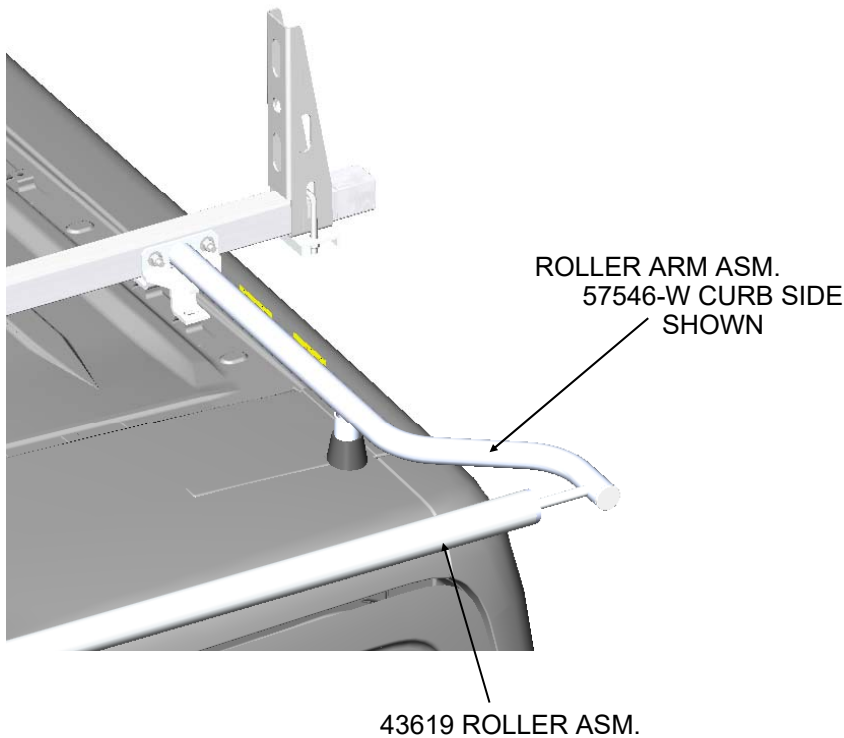

ASSEMBLE ONE END OF ROLLER OVER PIN ON INSTALLED ARM ASM. ASSEMBLE OPPOSITE SIDE ARM ASM SAME AS FIRST.

TORQUE ALL FASTENERS ON RACK TO 10-12 FT LBS



# Instructions for Step 3

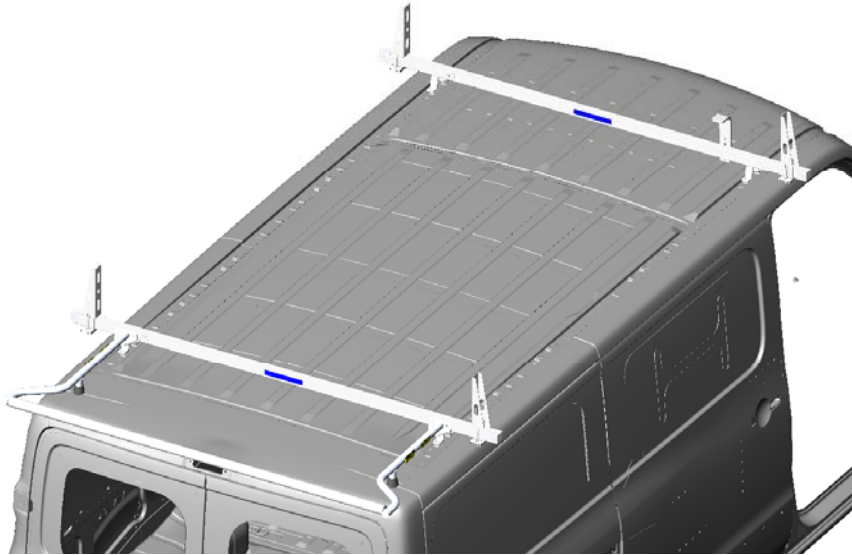

YOUR INSTALLATION IS NOW COMPLETE. THE ROLLER BAR ADDITION IS SHOWN INSTALLED AT LEFT ON A 2BNLCV-W . MAKE SURE ALL FASTENERS ARE PROPERLY TORQUED. CHECK FASTENERS AFTER 2 WEEKS AND AGAIN EVERY FEW WEEKS TO ASSURE PROPER PERFORMANCE OF YOUR RACK.

**NOTE : ALL CARGO MUST BE PROPERLY TIED DOWN TO RACK PRIOR TO TRANSPORT.**

**DOUBLE CHECK ALL FASTENERS LOCATIONS TO BE SURE THAT ALL FASTENERS ARE TIGHTENED TO SPECIFICATIONS.  
YOUR INSTALLATION IS NOW COMPLETE!  
STOW THIS COPY IN THE VEHICLE FOR FUTURE REFERENCES!**