

INSTR. NUMBER	PG:	REV:	ITEM NO.	PART NUMBER	DESCRIPTION	QTY.
: <b>64956</b>	<b>1</b>	<b>B</b>	1	64174	REAR ROLLER,BAR ASSM,62"	1
			2	64168-W	REAR ROLLER,DS WELD,GM,W	1
PART NUMBER : <b>RRBGMW</b>			3	64169-W	REAR ROLLER,PS WELD,GM,W	1
PART DESC. : UTILITY,REAR ROLLER,GM,W			4	22856-0	FOOT CLAMP - GMT600,WHITE	2

**NOTE: (IF NECESSARY,  
DELETE IF NOT USED)**

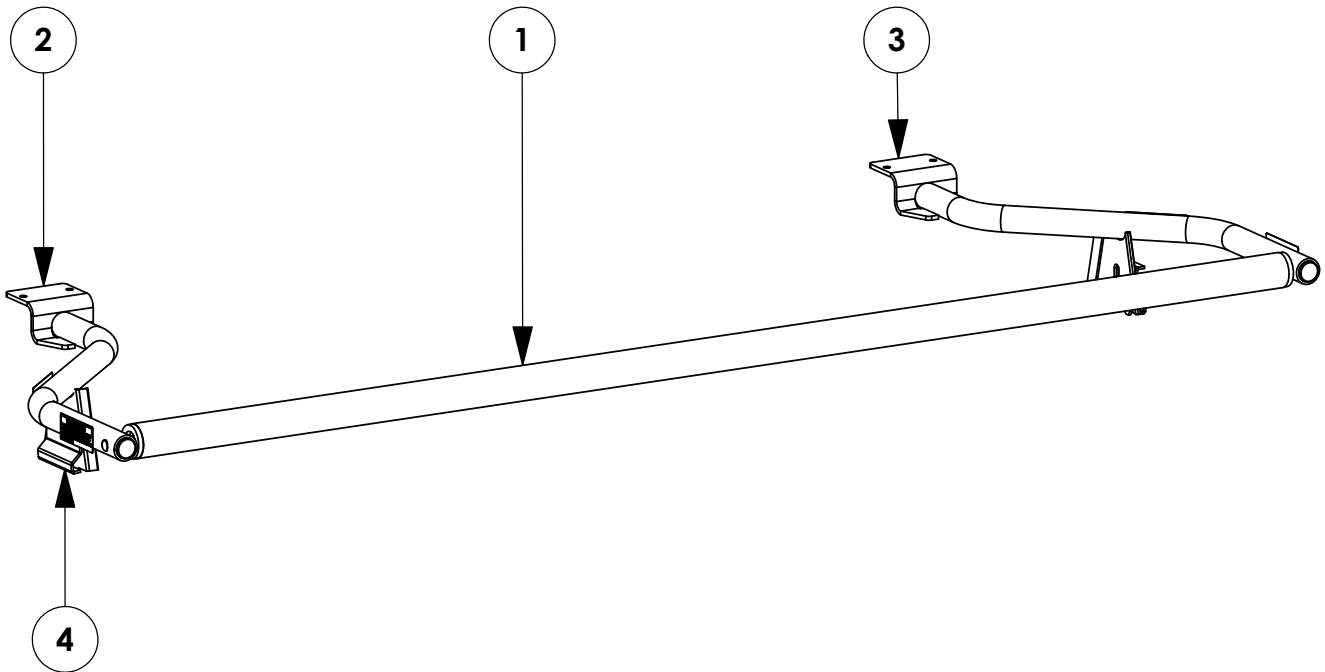

**GET TO KNOW THE VEHICLE** - AT THE BEGINNING OF ANY INSTALLATION, CHECK THE LOCATION OF THE FUEL TANK, FUEL LINES, BRAKE LINES, HIGH VOLTAGE BATTERIES AND WIRING HARNESSSES TO AVOID INJURY OR PROPERTY DAMAGE FROM TOOL CONTACT.

**SEAL ALL EXTERIOR HOLES** - ALL INSTALLATION HOLES SHOULD BE SEALED WITH BUTYL TAPE OR SILICON TO PREVENT WATER AND EXHAUST GASES FROM ENTERING THE VEHICLE.

**CONTROL DRILL DEPTH** - TO AVOID DAMAGE TO THE VEHICLE, USE A DRILL STOP OR CLEARED STEP BIT WHEN DRILLING INSTALLATION HOLES.

**ALWAYS ADD PRIMER** - WHEN ADDING INSTALLATION HOLES BE SURE TO USE A SELF-ETCHING PRIMER TO PREVENT CORROSION, FASTENER FAILURE AND INJURY.

**MOUNTING POINTS MUST HAVE METAL-TO-METAL CONTACT** - USE PROVIDED MOUNTING SPACERS TO ACCOMMODATE FOR VEHICLE FEATURES, CARPET OR SUBFLOORS.

**PROVIDE CLEARANCE FOR SPACERS** - IF THE INSTALLATION VEHICLE CONTAINS A CARPET OR SUBFLOOR, USE A 1-3/16" DIAMETER CARPET CUTTER (P/N: 31183-0) AT ALL MOUNTING LOCATIONS TO OPEN UP ROOM FOR SPACERS.

**CHECK SPACER ORIENTATION** - BE SURE THAT THE INDENT IN THE SPACER COVERS THE PLUSNUT HEAD; THIS ENSURES THE MOST METAL-TO-METAL CONTACT AND REDUCES VIBRATION.

**PLUSNUT INSTALLATION** - A PLUSNUT GUN IS RECOMMENDED FOR PLUSNUT INSTALLATION FOR ITS PRODUCTION SPEED. HOWEVER, A PLUSNUT SETTING TOOL CAN ALSO BE USED (P/N: 22200-0).

**THRU-BOLT CLEARANCE** - WHEN USING A THRU-BOLT AT ANY MOUNTING LOCATION, BE SURE THAT YOUR HOLE HAS 1/16" CLEARANCE.

**FASTENERS USED**

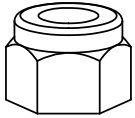

**FAS0110**  
3/8-16 SS  
NLK HEX NUT  
QTY: 2

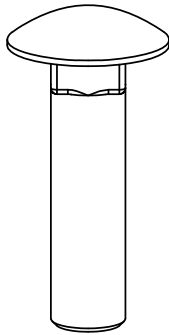

**FAS0117**  
3/8-16X1.5 SS  
CRG BOLT  
QTY: 2

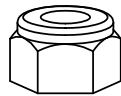

**FAS0248**  
5/16-18 SS  
NLK HEX NUT  
QTY: 4



**FAS0552**  
5/16 SS  
FLAT WASHER  
QTY: 4

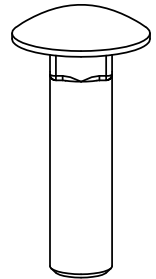

**FAS0812**  
5/16-18 SS  
CRG BOLT  
QTY: 4

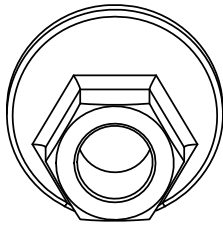

**07466-0**  
ADJUSTING  
CAM NUT  
QTY: 2

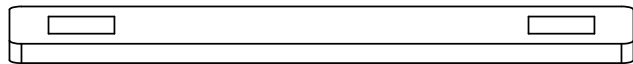

**64830**  
REAR ROLLER  
BOLT PLATE  
QTY: 2

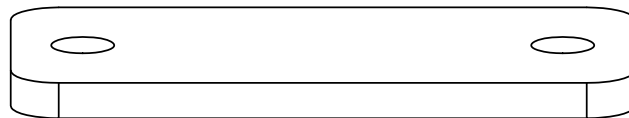

**64831**  
REAR ROLLER  
SPACER  
QTY: 2

**BEGIN ASSEMBLY**

**STEP 1 - ATTACH ROLLER ARMS TO CROSSBOW**

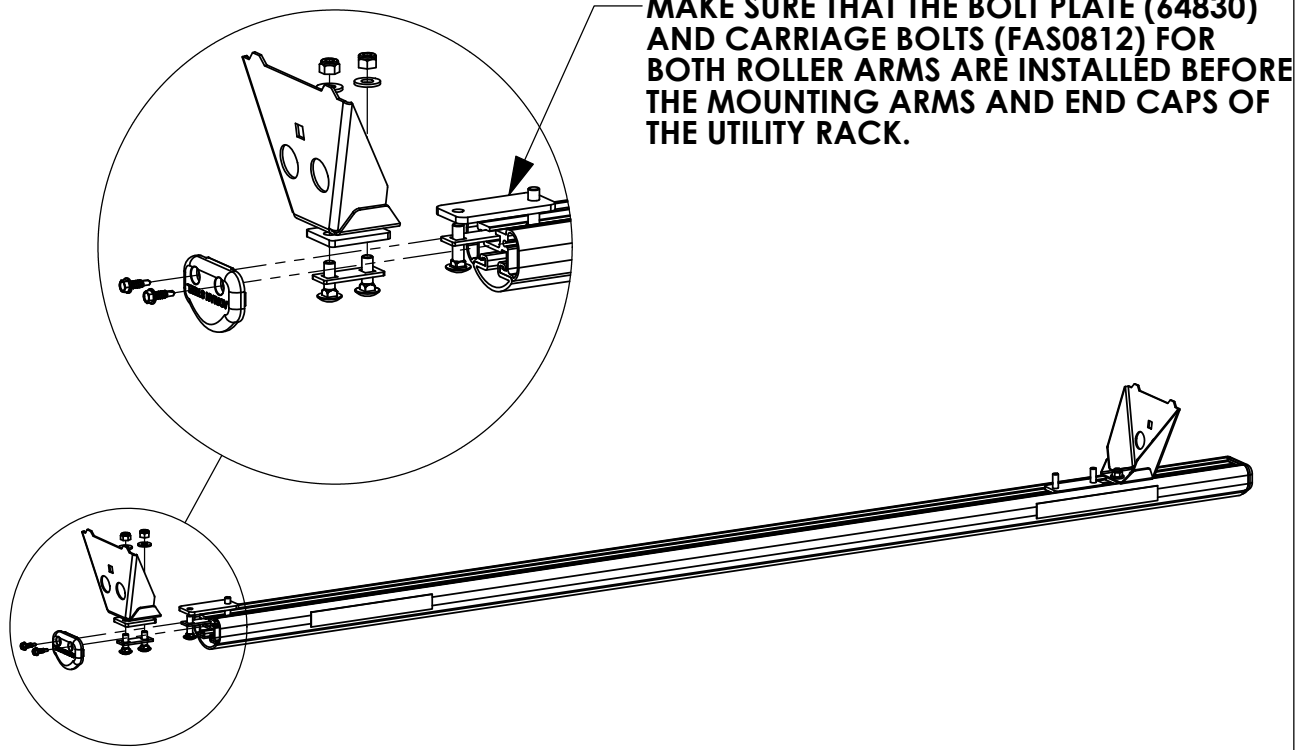

**STEP 2 - ADD ROLLER BAR & SECURE**

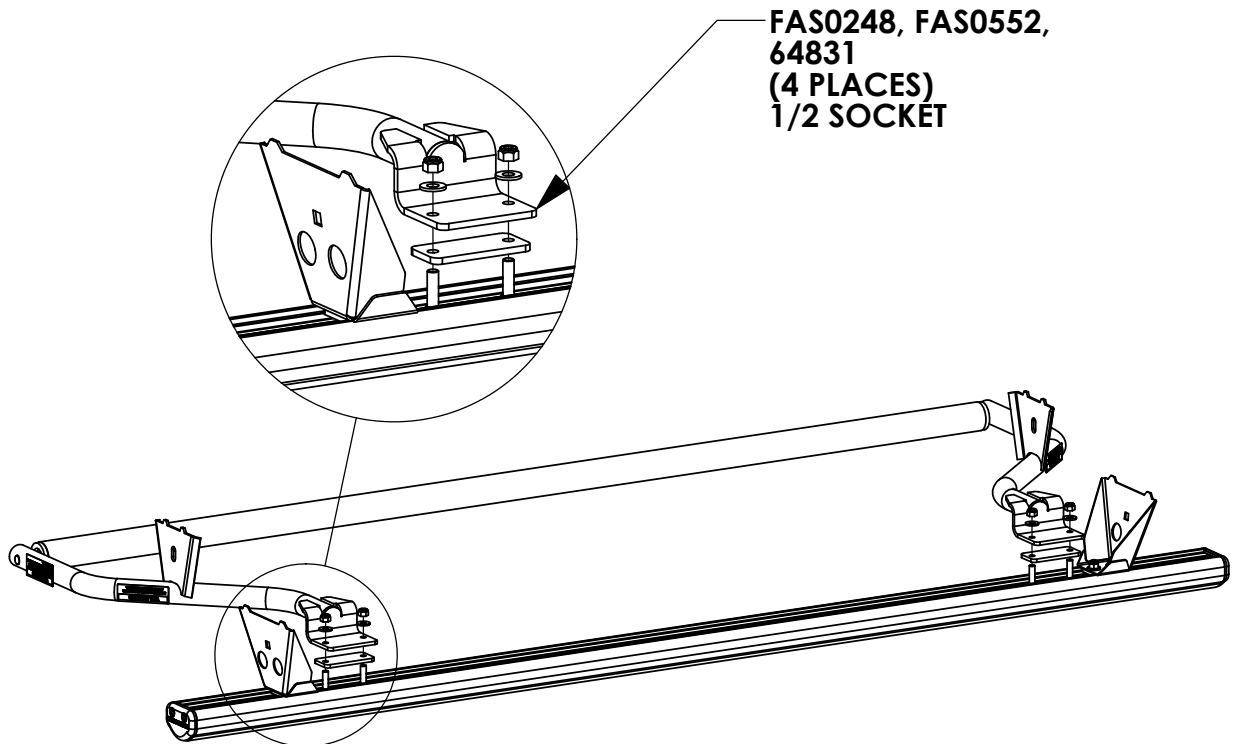

**BEGIN INSTALLATION  
STEP 3 - SECURE ROLLER ARMS TO ROOF**

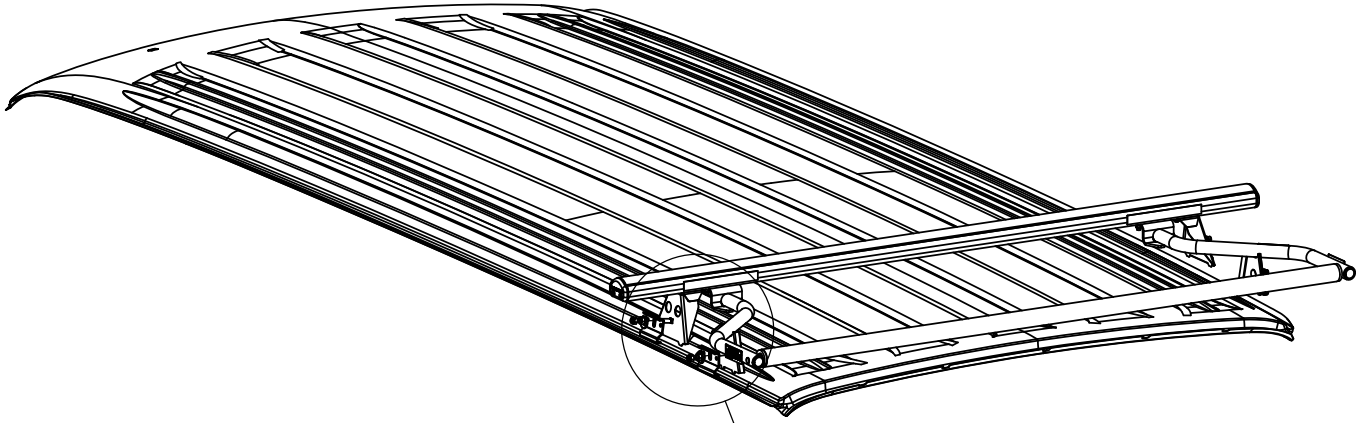

**DO NOT OVERTIGHTEN  
ECCENTRIC WASHER!**

**FAS0110, 07466-0,  
FAS0117  
(2 PLACES PER CROSSBOW)  
(2 PLACES PER ROLLER)  
9/16 SOCKET  
5/8 WRENCH**

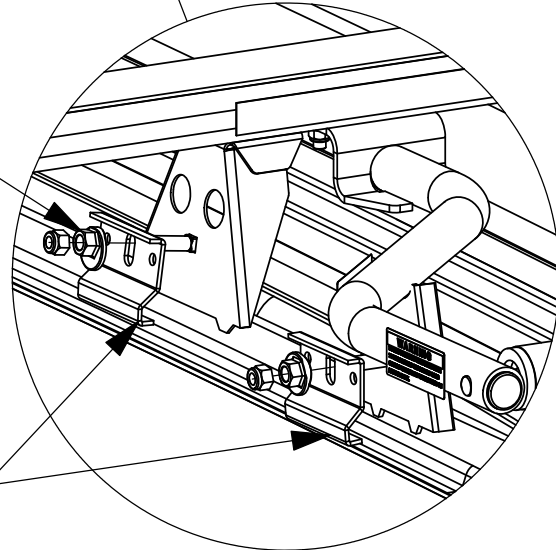

**CROSSBOW PLACEMENT MEASUREMENT**

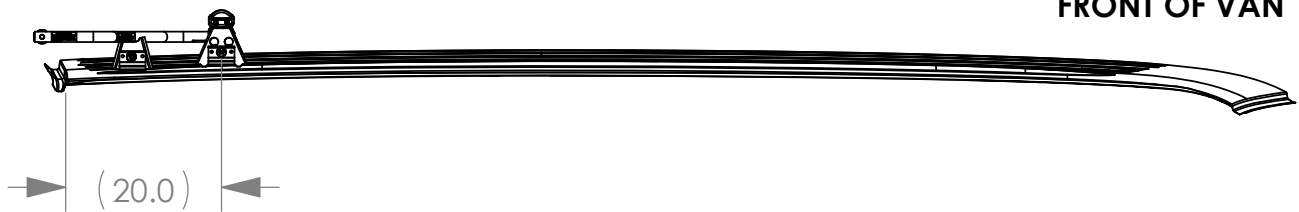

**FRONT OF VAN**