



PRODUCT WEIGHT
10 LBS

WIDTH x DEPTH x HEIGHT
71.8" x 19" x 5"

CAPACITY
200 LBS

COLOR
BLACK / WHITE

CATALOG NUMBER
RRBFTRP2 -B/-W

PRODUCT FEATURES

**REAR ROLLER KIT FOR THE FORD TRANSIT AND RAM PRO-
MASTER UTILITY RACK. FOR USE WITH THE 3BFT, 2BFT, 3BPM,
AND 2BPM.**

ALLOWS FOR EASE OF LOADING

**SEE PAGE 2 FOR APPLICATION NOTES AND ACCESSORIES, OTHER PRODUCTS THAT
WORK WITH THIS UNIT.**



CATALOG NUMBER RRBFTPR -B/-W

PRODUCT APPLICATION

THIS PRODUCT IS DESIGNED FOR THE FORD TRANSIT AND RAM PRO-MASTER STD ROOF VAN. WILL FIT BOTH AVAILABLE WHEELBASES

ACCESSORIES THAT WILL WORK WITH THIS PRODUCT

<i>CATALOG NUMBER</i>	<i>DESCRIPTION</i>
------------------------------	---------------------------

SPECIAL APPLICATION NOTES

Introduction / Comments:

This Rear roller is designed to fit in the Dodge 2BARRPM AND 3BARRPM, and the Ford 2BARRFT AND 3BARRFT. THIS ONLY FITS THE STANDARD ROOF PROMASTER AND TRANSIT, **DOES NOT FIT ON THE HIGH ROOF VERSIONS.**

Note:

It is advised that all fasteners used in this assembly and installation should be checked for tightness at the following intervals: @ 2-weeks and again @ 6-weeks of operation. This preventive maintenance step must be completed to ensure your Rear Roller gives you long service life.

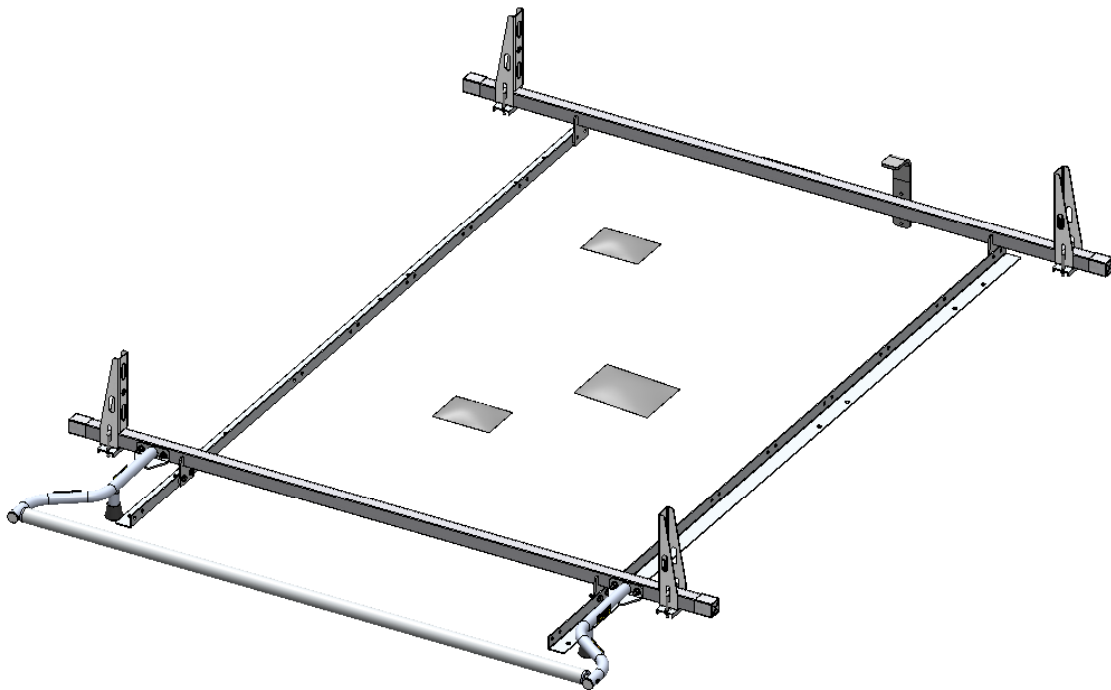

RRBFTRP2-W SHOWN
ATTACHED TO 2BFT-W FOR REFERENCE

RRBFTPM-B and RRBFTPM-W
Utility Racks for Ford Transit / Dodge Promaster
Std Roof Vans

- PRECAUTIONS -



CAUTION
THE USE AIR IMPACT TOOLS CAN
OVER-TORQUE FASTENERS AND
CAUSE FASTENER FAILURE!



CAUTION
ALL INSTALLATION HOLES SHOULD BE SEALED
WITH SILICON OR BUTYL SEALANT TO PREVENT
EXHAUST FUMES FROM ENTERING THE VEHICLE!



DANGER
INSPECT FOR FUEL TANK, FUEL LINES, BRAKE LINES, HIGH
VOLTAGE BATTERIES AND ELECTRICAL LINES PRIOR TO
DRILLING TO AVOID DAMAGING CRITICAL VEHICLE SYSTEMS
OR INJURY TO INSTALLER DURING INSTALLATION PROCESS!



CAUTION
TO AVOID DAMAGING THE VEHICLE ALWAYS
USE DRILL STOPS WHEN DRILLING ANY IN-
STALLATION HOLES!



- IMPORTANT WARRANTY REQUIREMENTS -

1. SUBSTITUTING ADRIAN STEEL SPECIFIED FASTENERS FOR ASSEMBLY AND/OR INSTALLATION WILL VOID YOUR PRODUCT WARRANTY.
2. ALL HOLES DRILLED INTO VEHICLE SHOULD HAVE THE RAW METAL EDGES SEALED WITH A SELF-ETCHING PRIMER TO RESIST CORROSION AND POTENTIAL FASTENER POINT FAILURE.
3. ALL FASTENERS USED IN THE INSTALLATION OF THIS PRODUCT SHOULD BE TIGHTENED TO THE TORQUE(S) SPECIFIED IN THESE INSTRUCTIONS.
4. THESE INSTRUCTIONS SHOULD BE KEPT WITH THE VEHICLE.

THE BASIC TOOLS NEEDED FOR MOST INSTALLATIONS



DRILL



DRILL BIT WITH
STOP



RATCHET, SOCKETS
AND/OR WRENCHES



SCREWDRIVERS





MEASURING TAPE

ADDITIONAL TOOLS MAY BE NEEDED FOR THIS INSTALLATION AND THEY WILL BE IDENTIFIED IN THE STEPS THAT FOLLOW.

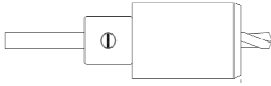

WHEN INSTALLING PLUSNUTS MAKE SURE YOU USE THE CORRECT DRILL BIT SIZE WITH A STOP!

PLUSNUT SIZE	DRILL BIT SIZE
1/4-20 PLUSNUT, FAS0052	USE A 3/8" DIAMETER DRILL BIT WITH A STOP.
5/16-18 PLUSNUT, FAS0091	USE A 1/2" DIAMETER DRILL BIT WITH A STOP.
  NOTE: A PLUSNUT SETTING TOOL IS REQUIRED FOR PLUSNUT INSTALLATION AND IS NOT SUPPLIED WITH THIS KIT. ORDER PLUSNUT TOOLS FROM ADRIAN STEEL (P.N. 22200-0) OR USE AN AIR POWERED PLUSNUT SETTING GUN.	
NOTE: If your vehicle contains carpet or a rubber floor mat you will need to prepare the mounting locations using a 1-3/16" carpet cutter.	1-3/16" DIAMETER CARPET CUTTER P.N. 31183-0. 

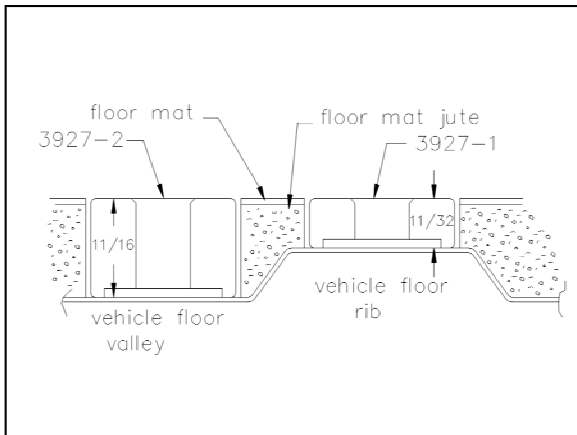

Step 01
Optional Based on Vehicle

If your vehicle contains carpet or a rubber floor mat you will need to prepare the mounting locations. **(if not, skip to STEP 02)**

Position the product to be installed into the vehicle and once you are satisfied with the mounting locations, mark the mounting locations. Using a 1-3/16" diameter carpet cutter. Select the appropriate floor spacers as shown in the illustration to the left. Set those aside for use later into the installation process.

Once you have prepared the carpet/floor mat for mounting, proceed to **STEP 02**.

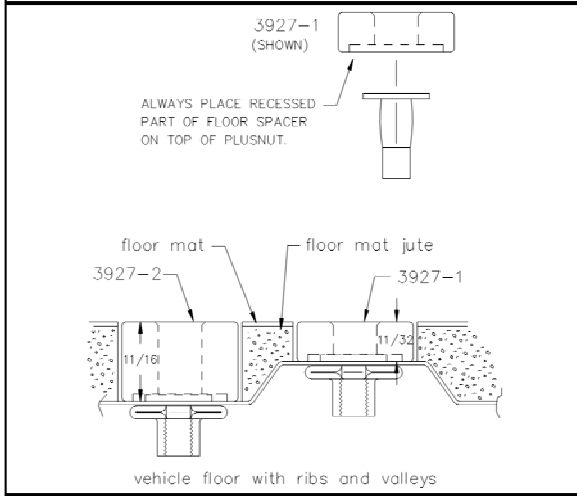

Step 02
Prepare Mounting Locations

Using a drill and drill bit (see table at top of page for correct size) drill the mounting holes in the vehicle sheet metal to prepare for installing the plusnuts.

If you are thru-bolting at any of the locations simply drill a hole that is 1/16" larger than the bolt size(s) for those locations.

Once you have drilled the holes into the vehicle, the raw metal edges should be sealed using a self-etching primer to resist corrosion and potential fastener point failure.

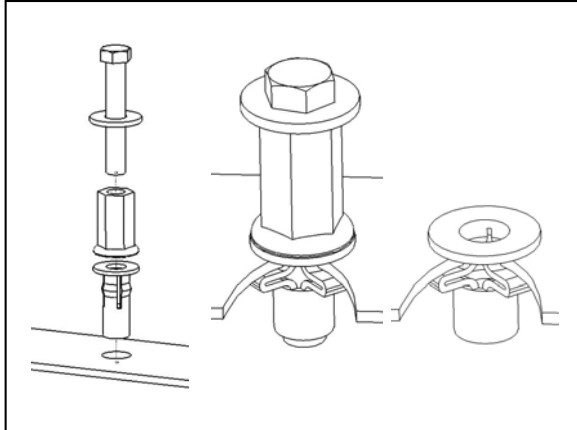

Step 03
Setting Plusnuts

Use a Air Powered Plusnut Setting Gun to "set the plusnut" or if installing manually with hand tools, assembly the following.

1/4-20UNC Plusnut (FAS0052)
FAS0080 SCREW, HXHD, 1/4-20UNCx2.00, G8
FAS0067 WASHER, FLAT, 1/4"ID
22200-0 PLUSNUT TOOL

5/16-18UNC Plusnut (FAS0091)
FAS0095 SCREW, HXHD, 5/16-18UNCx2.00", G8
FAS0086 WASHER, FLAT, 5/16"ID
22200-0 PLUSNUT TOOL

Place barrel of the plusnut body in sheet metal thru hole until flange is flush with sheet metal.

Using a 9/16" combination wrench of plusnut tool body and a second hand wrench, ratchet, or air tool, rotate the hex bolt head CW to draw plus nut flanges up (set the plusnut).

Remove hex bolt, washer, and plusnut. Inspect installation.





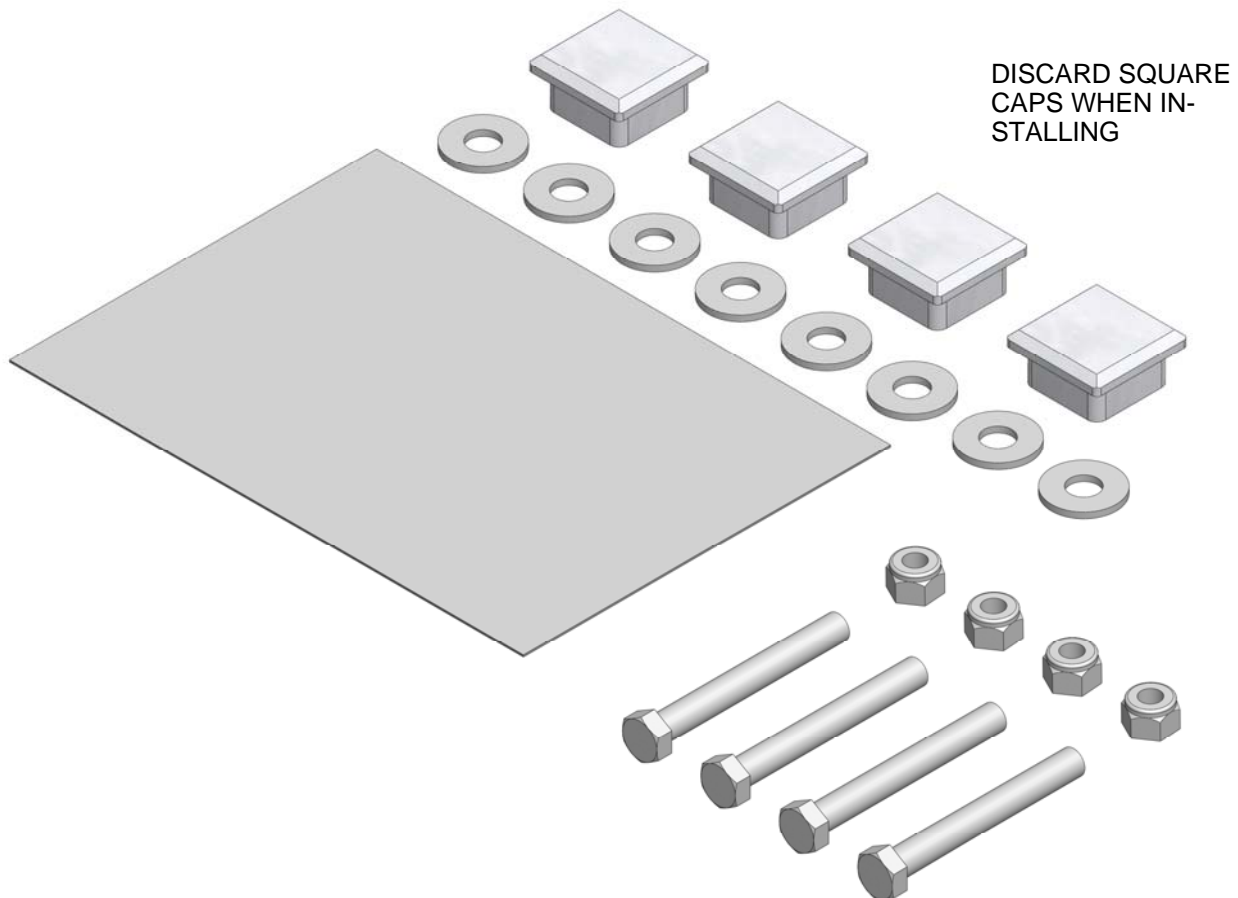

**Installation and/or Assembly Fasteners
BAGRRBDPM**

BILL OF MATERIAL AND FASTENER BAG FOR
BAGRRBDPM

ITEM NO.	PART NUMBER	DESCRIPTION	BAGRRBDPM/QTY.
1	BAG0507-A	5" x 7" 3MIL AUTOBAG	1
2	35017-0	SQUARE TUBE PLUG	4
3	FAS0243	Screw, Hex Hd, 5/16-18x2.50 Stainless Steel	4
4	FAS0248	Nut, Nylon Insert Lock, 5/16-18 SST	4
5	FAS0552	Washer, Flat, 5/16, SST	8





<p>PARTS YOU WILL USE FOR</p> <p>STEP 1</p>	59640-W RLR SPT ARM FT/PM SS (1) REQ'D	59641-W RLR SPT ARM FT/PM CS (1) REQ'D		
				
	FAS0243 5/16-18 X 2.50 HEX SCREW (2) REQ'D	FAS0552 5/16" FLAT WASHER (4) REQ'D	FAS0248 5/16-18 HEX NUT (2) REQ'D	
				

Instructions for Step 1

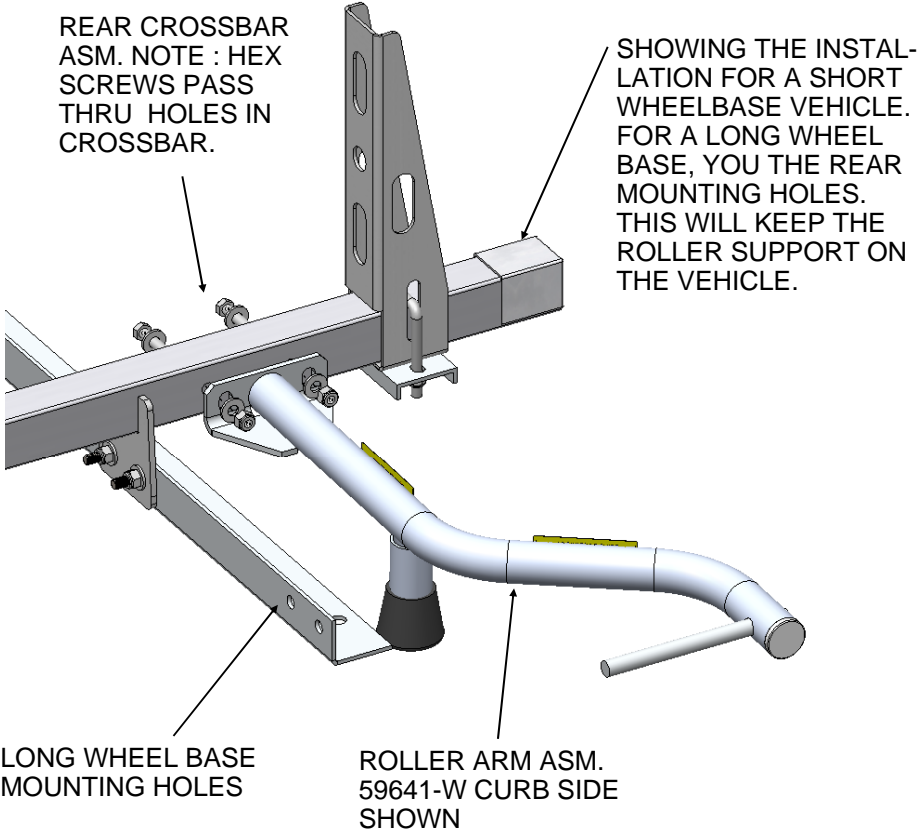

REAR CROSSBAR ASM. NOTE : HEX SCREWS PASS THRU HOLES IN CROSSBAR.

SHOWING THE INSTALLATION FOR A SHORT WHEELBASE VEHICLE. FOR A LONG WHEELBASE, YOU THE REAR MOUNTING HOLES. THIS WILL KEEP THE ROLLER SUPPORT ON THE VEHICLE.

LONG WHEEL BASE MOUNTING HOLES

ROLLER ARM ASM. 59641-W CURB SIDE SHOWN

ASSEMBLE ONE ROLLER ARM ASM TO REAR CROSSBAR AS SHOWN. CLEAN ROOF AREA WHERE LOWER LEG OF ROLLER ARM WILL CONTACT. PEEL BACKING FROM TAPE ON UNDER-SIDE OF ROLLER ARM LEG SO IT WILL STICK TO ROOF. TORQUE FASTENERS TO 12 FT LBS.



PARTS YOU WILL USE FOR	43619 REAR ROLLER ASM (1) REQ'D			
				

STEP 2

Instructions for Step 2

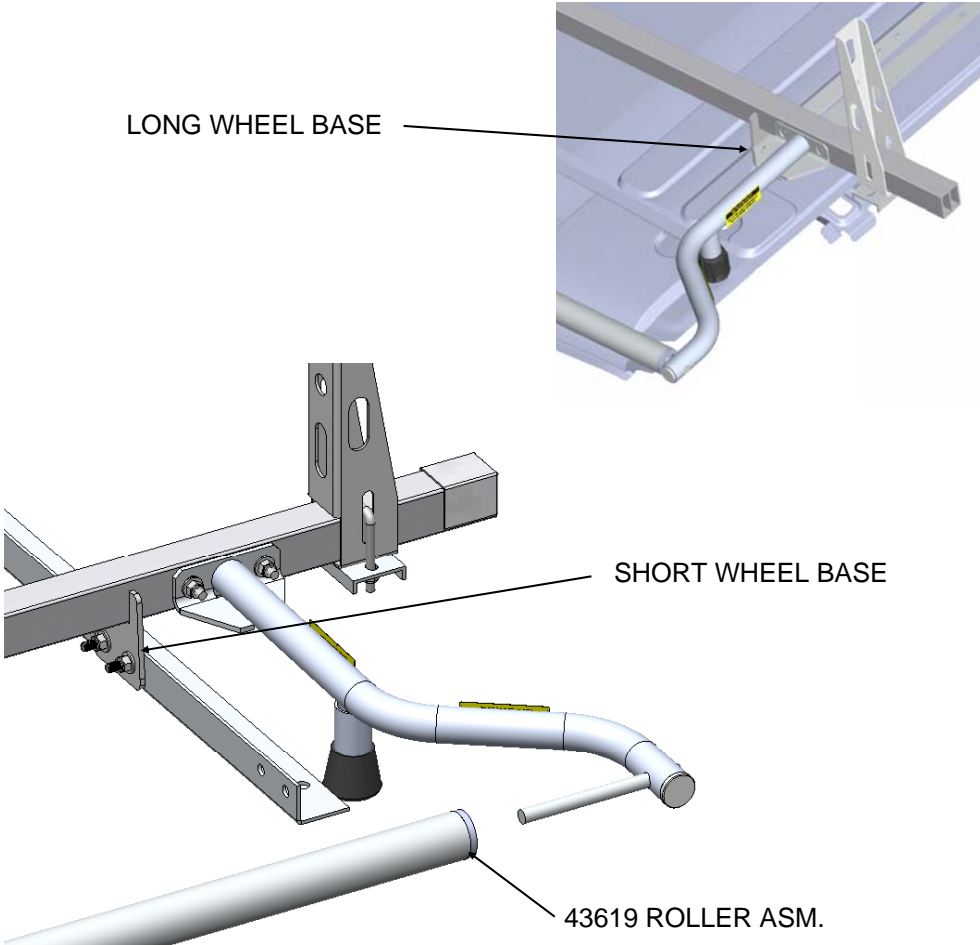

LONG WHEEL BASE

SHORT WHEEL BASE

43619 ROLLER ASM.

ASSEMBLE ONE END OF ROLLER OVER PIN ON INSTALLED ARM ASM. ASSEMBLE OPPOSITE SIDE ARM ASM SAME AS FIRST.

TORQUE ALL FASTENERS ON RACK TO 10-12 FT LBS



Instructions for Step 3

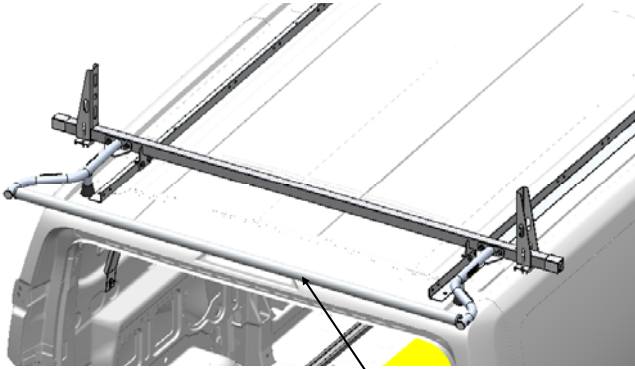

SHORT WHEEL BASE VEHICLE

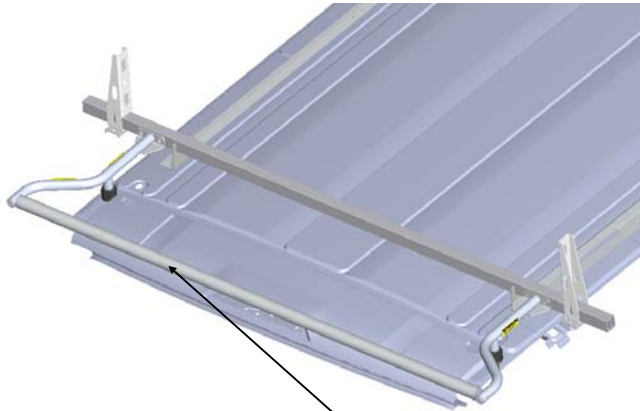

LONG WHEEL BASE VEHICLE

YOUR INSTALLATION IS NOW COMPLETE. THE ROLLER BAR ADDITION IS SHOWN INSTALLED AT LEFT ON A 2BFT-W. MAKE SURE ALL FASTENERS ARE PROPERLY TORQUED. CHECK FASTENERS AFTER 2 WEEKS AND AGAIN EVERY FEW WEEKS TO ASSURE PROPER PERFORMANCE OF YOUR RACK.

NOTE : ALL CARGO MUST BE PROPERLY TIED DOWN TO RACK PRIOR TO TRANSPORT.



Installation note : OEM antenna

GENERIC RACK SHOWN

2020 TRANSIT SHARK FIN INTERFERENCE

MOVE FRONT BAR ASSEMBLY TO THIS SET OF HOLES.

IF YOUR RACK IS NEAR THE OEM ANTENNA, YOU MAY HAVE TO MOVE THE BAR ASSEMBLY TO THE NEXT SET OF HOLES.

**DOUBLE CHECK ALL FASTENERS LOCATIONS TO BE SURE THAT ALL FASTENERS ARE TIGHTENED TO SPECIFICATIONS.
YOUR INSTALLATION IS NOW COMPLETE!
STOW THIS COPY IN THE VEHICLE FOR FUTURE REFERENCES!**