

INSTR. NUMBER : **69484**

PG: **1** REV: **A**

PART NUMBER • **Standard Drop ProLift**
• **Low & Compact Vans**

PART DESC. • ProLift Adjustment Instructions -
• **Standard Drop**
• **Low Roof & Compact Vans**

Step 3: With 1/2" Socket loosen nut, slide post so that it is snug against the ladder. Tighten nut

Step 1: With 1/2" Socket loosen nut, slide post so that it is snug against the ladder. Tighten nut

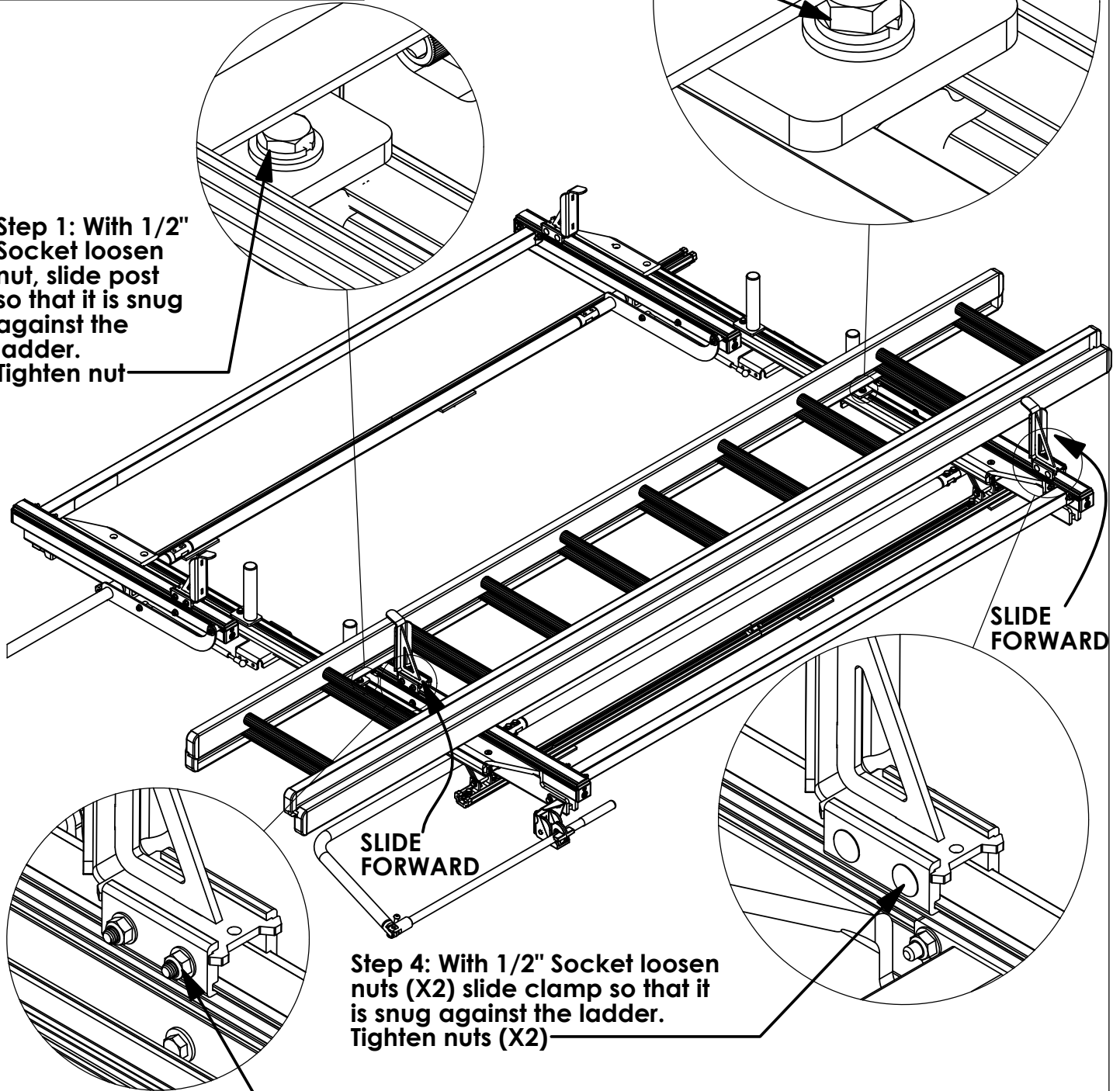

Step 4: With 1/2" Socket loosen nuts (X2) slide clamp so that it is snug against the ladder. Tighten nuts (X2)

Step 2: With 1/2" Socket loosen nuts (X2) slide clamp so that it is snug against the ladder. Tighten nuts (X2)

Once all brackets are adjusted operate rack to make sure clamps are not too tight

INSTR. NUMBER	PG:	REV:	ITEM NO.	PART NUMBER	DESCRIPTION	QTY.
: 68497	1	C	1	68298-W	STD DROP CARTRIDGE, LR DS, WHITE	1
			2	68013-W	DROP DOWN FRONT ARM ASM DS, WHITE	1
			3	66563-B	DROP DOWN, SS CENTER DRIVELINE, BLK	1
PART NUMBER : PLSDPSL & PLSDDSL			4	66959-W	DROP DOWN OUTER BAR, WELDMENT, WHITE	1
			5	66611-B	DROP DOWN, PIVOT HANDLE, BLK	1
PART • PROLIFT,STD,PS,LR DESC. • & PROLIFT,STD,DS,LR			6	58239	COMPRESSION DAMPER	1
			7	48265	DAMPER ASSEMBLY	1
PLSDDSLW			8	68186-W	PROLIFT INNER POST, WHITE	2
			9	68180-W	DROP DOWN LATCH BRACKET, WHITE	1
			10	25340-0	HANDLE LATCH-STD	1
			11	68037-B	CLAMP PAD, 6.5", BLACK	2
			12	68045-W	PROLIFT DAMPER MOUNT, WHITE	2

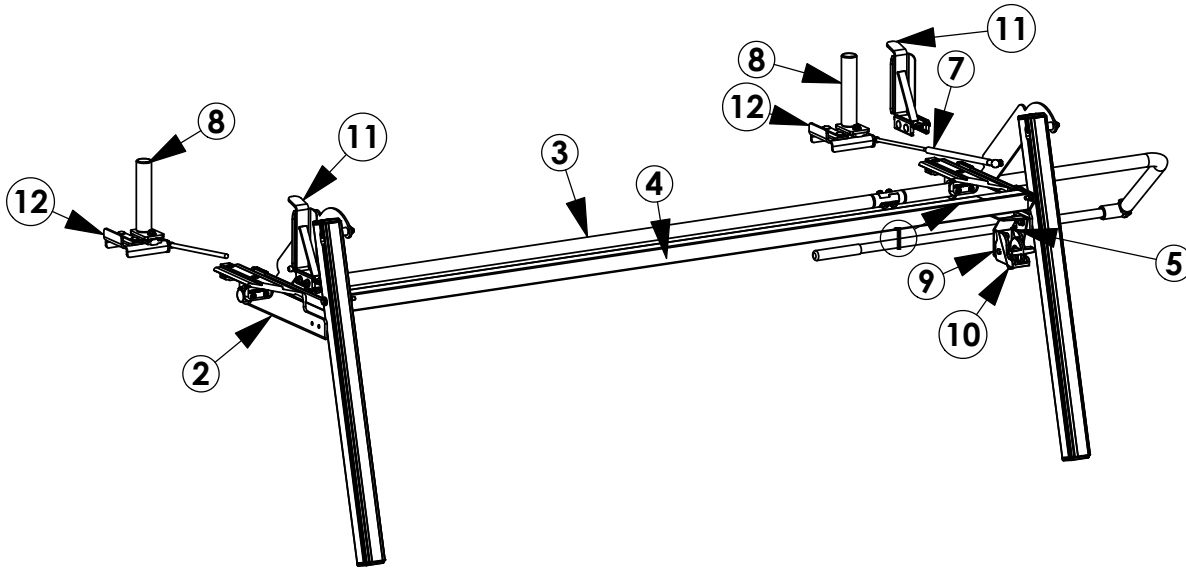

ITEM NO.	PART NUMBER	DESCRIPTION	QTY.
1	68297-W	STD DROP CARTRIDGE, LR PS, WHITE	1
2	68031-W	DROP DOWN FRONT ARM ASSM PS, WHITE	1
3	66572-B	DROP DOWN, CS CENTER DRIVELINE, BLK	1
4	66959-W	DROP DOWN OUTER BAR, WELDMENT, WHITE	1
5	66611-B	DROP DOWN, PIVOT HANDLE, BLK	1
6	58239	COMPRESSION DAMPER	1
7	48265	DAMPER ASSEMBLY	1
8	68045-W	PROLIFT DAMPER MOUNT, WHITE	2
9	68186-W	PROLIFT INNER POST, WHITE	2
10	68180-W	DROP DOWN LATCH BRACKET, WHITE	1
11	25340-0	HANDLE LATCH-STD	1
12	68037-B	CLAMP PAD, 6.5", BLACK	2

PLSDPSLW

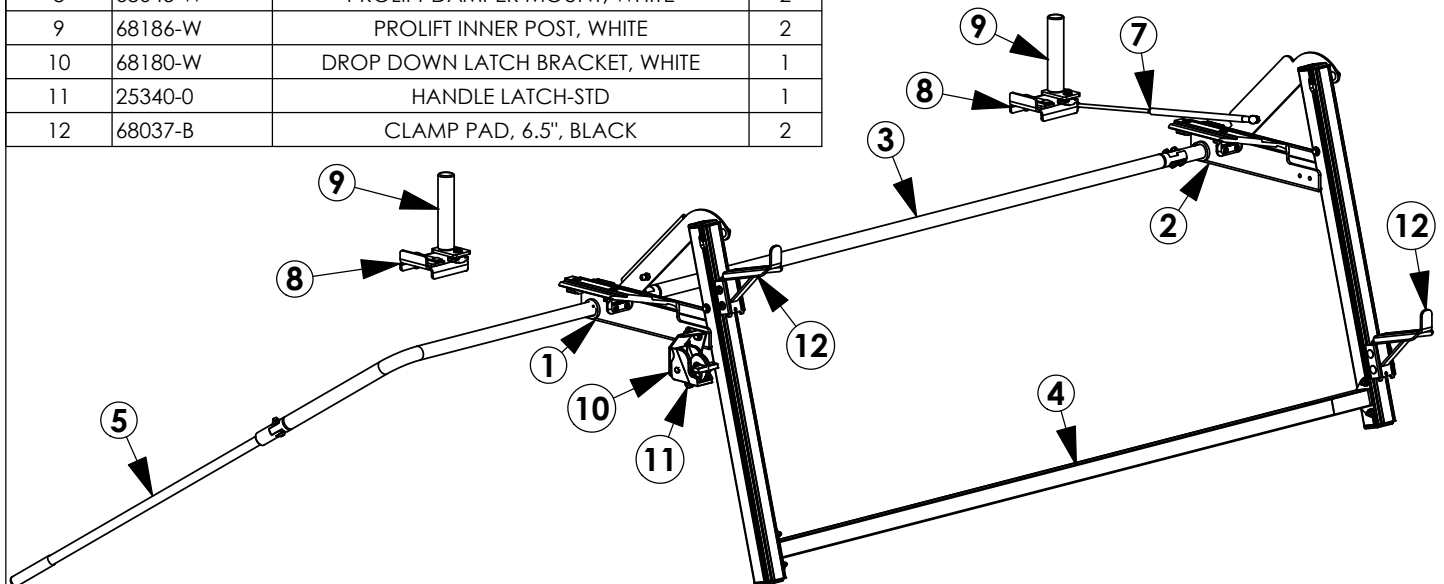

GET TO KNOW THE VEHICLE - AT THE BEGINNING OF ANY INSTALLATION, CHECK THE LOCATION OF THE FUEL TANK, FUEL LINES, BRAKE LINES, HIGH VOLTAGE BATTERIES AND WIRING HARNESSSES TO AVOID INJURY OR PROPERTY DAMAGE FROM TOOL CONTACT.

SEAL ALL EXTERIOR HOLES - ALL INSTALLATION HOLES SHOULD BE SEALED WITH BUTYL TAPE OR SILICON TO PREVENT WATER AND EXHAUST GASES FROM ENTERING THE VEHICLE.

CONTROL DRILL DEPTH - TO AVOID DAMAGE TO THE VEHICLE, USE A DRILL STOP OR CLEARED STEP BIT WHEN DRILLING INSTALLATION HOLES.

ALWAYS ADD PRIMER - WHEN ADDING INSTALLATION HOLES BE SURE TO USE A SELF-ETCHING PRIMER TO PREVENT CORROSION, FASTENER FAILURE AND INJURY.

MOUNTING POINTS MUST HAVE METAL-TO-METAL CONTACT - USE PROVIDED MOUNTING SPACERS TO ACCOMMODATE FOR VEHICLE FEATURES, CARPET OR SUBFLOORS.

PROVIDE CLEARANCE FOR SPACERS - IF THE INSTALLATION VEHICLE CONTAINS A CARPET OR SUBFLOOR, USE A 1-3/16" DIAMETER CARPET CUTTER (P/N: 31183-0) AT ALL MOUNTING LOCATIONS TO OPEN UP ROOM FOR SPACERS.

CHECK SPACER ORIENTATION - BE SURE THAT THE INDENT IN THE SPACER COVERS THE PLUSNUT HEAD; THIS ENSURES THE MOST METAL-TO-METAL CONTACT AND REDUCES VIBRATION.

PLUSNUT INSTALLATION - A PLUSNUT GUN IS RECOMMENDED FOR PLUSNUT INSTALLATION FOR ITS PRODUCTION SPEED. HOWEVER, A PLUSNUT SETTING TOOL CAN ALSO BE USED (P/N: 22200-0).

THRU-BOLT CLEARANCE - WHEN USING A THRU-BOLT AT ANY MOUNTING LOCATION, BE SURE THAT YOUR HOLE HAS 1/16" CLEARANCE.

FASTENERS AND HARDWARE USED

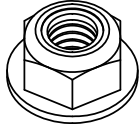

FAS0861
NUT,HEX NLK FLG 5/16-18
QTY: 18



FAS0110
NUT,HEX NLK 3/8-16
QTY: 01



FAS0399
NUT,HEX NLK LT 3/8-16
QTY: 01

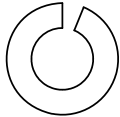

FAS0588
WASHER,LCK SPLIT 5/16
QTY: 03

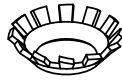

FAS0857
WASHER,LCK EXT CS 5/16
QTY: 04

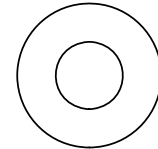

FAS0552
WASHER,FLAT USS 5/16
QTY: 09

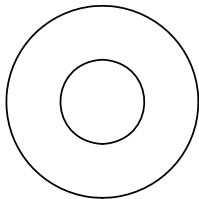

FAS0720
WASHER,FLAT USS 3/8
QTY: 01

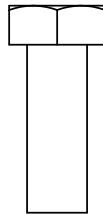

FAS0283
SCREW,HH 5/16-18X.875
QTY: 02

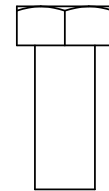

FAS0799
SCREW,HH 5/16-18X.75
QTY: 02

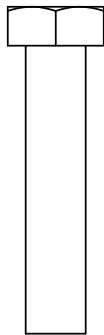

FAS0242
SCREW,HH 5/16-18X1.5
QTY: 04

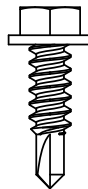

FAS0473
SCREW,HH TEK #12X.75
QTY: 04



FAS0856
SCREW,FHH 5/16-18X1.13
QTY: 04

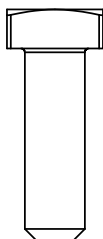

FAS0035
BOLT,SQ HD 5/16-18X1.0
QTY: 08

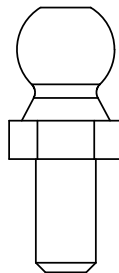

34927-0
BALL STUD 13MM X 5/16-18
QTY: 02

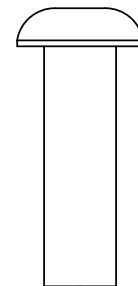

FAS0701
SCREW,BHCS 3/8-16X1.25
QTY: 01

FASTENERS AND HARDWARE USED

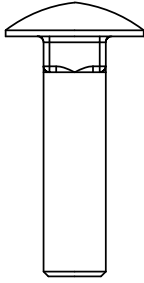

FAS0812
BOLT,CRG 5/16-18X1.25
QTY: 04

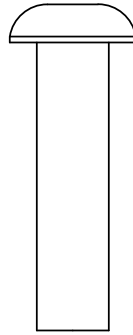

FAS0819
SCREW,BHCS 3/8-16X1.5
QTY: 01

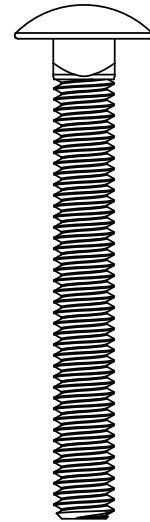

FAS0838
BOLT,CRG 5/16-18X2.5
QTY: 04

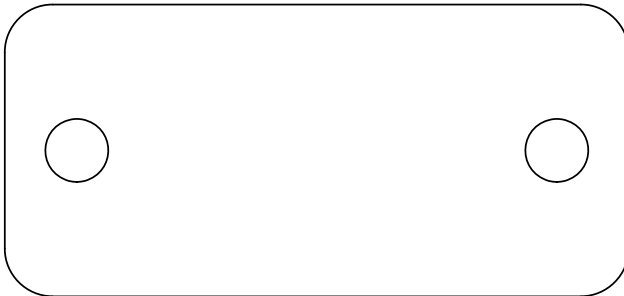

64831
REAR ROLLER, SPACER
QTY: 02

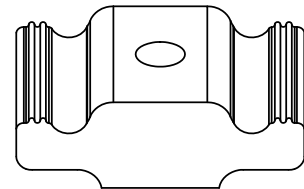

63490
RAIL SLIDE, 1"
QTY: 06



64830
REAR ROLLER, BOLT PLATE
QTY: 02

DISCARD

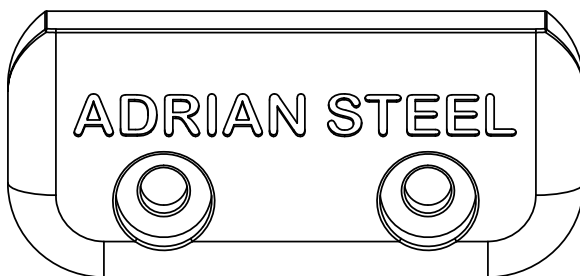

65961
DROP DOWN END CAP
QTY: 02

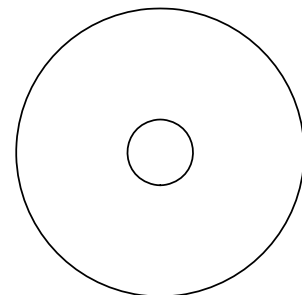

FAS0603
SCREW,HH 5/16-18X.875
QTY: 02

BEGIN ASSEMBLY

STEP 1 - INSTALL CLAMPS AND HARDWARE ON DROP DOWN CARTRIDGES

**PASSENGER SIDE
CARTRIDGES**

**REAR SUB-
ASSEMBLY**

MUST BE THIS ORIENTATION!

**FRONT SUB-
ASSEMBLY**

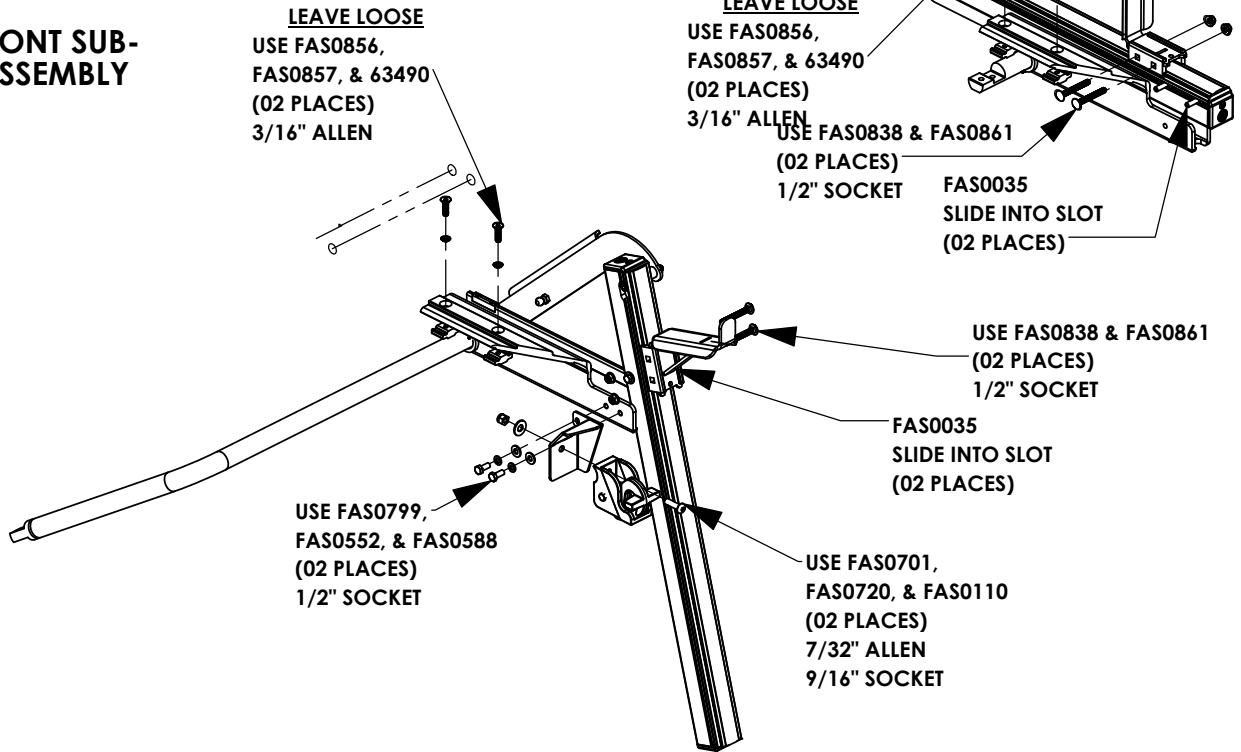

**DRIVER SIDE
CARTRIDGES**

**REAR SUB-
ASSEMBLY**

MUST BE THIS ORIENTATION!

**FRONT SUB-
ASSEMBLY**

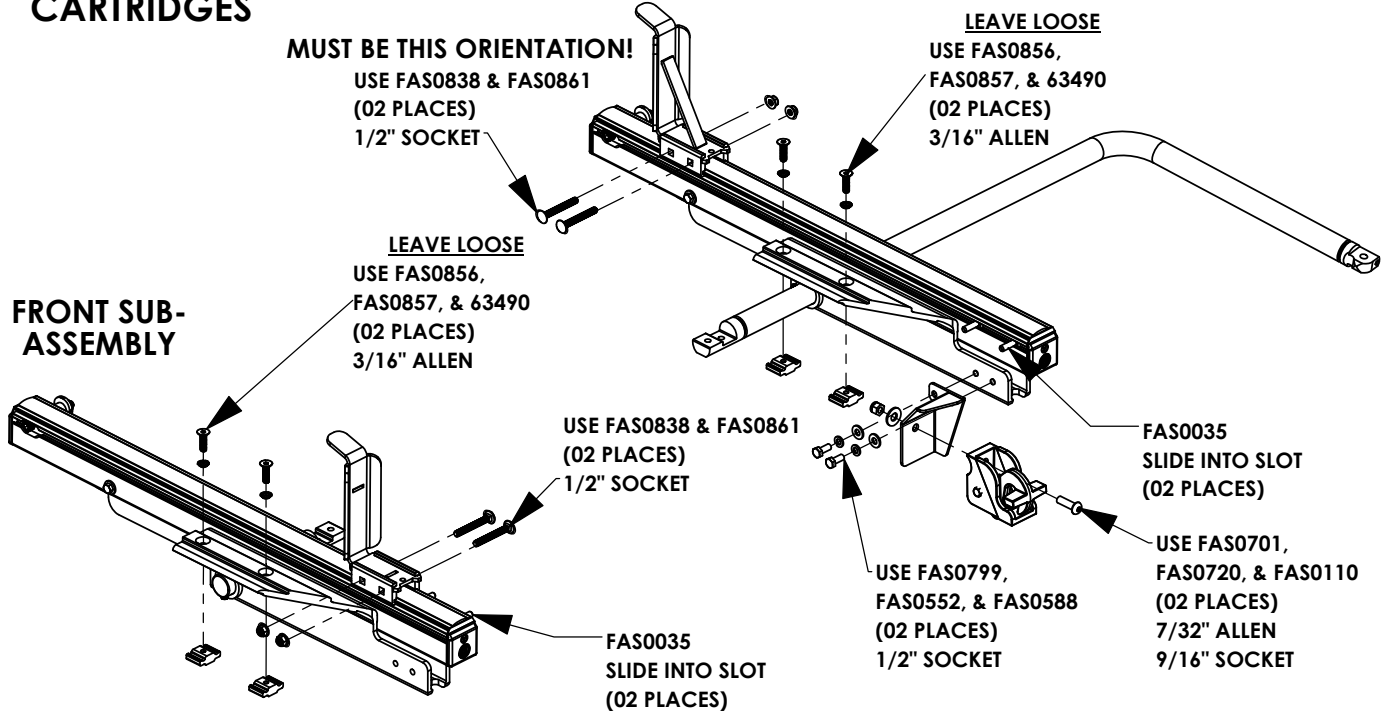

STEP 2 - MOUNT DAMPER BRACKETS AND INNER STOPS TO CROSSBOWS

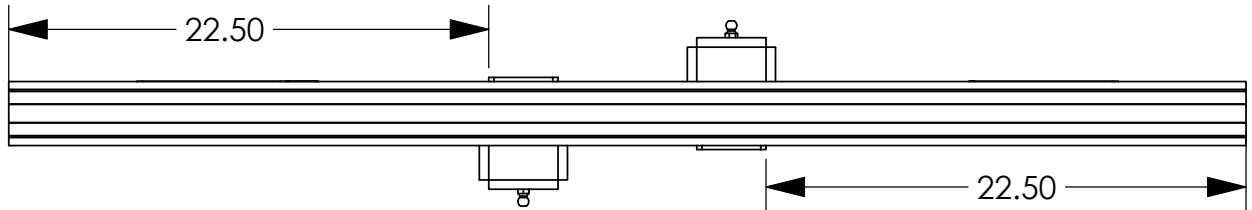
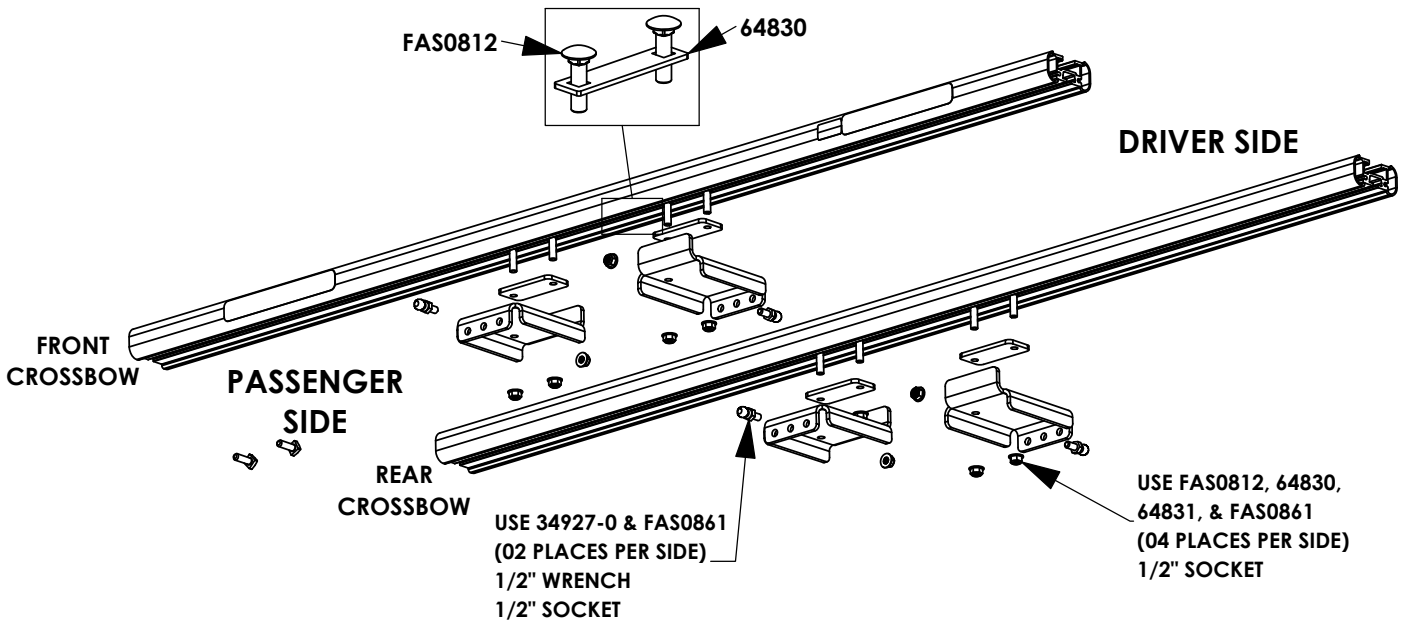

MOUNT 22" FROM THE END OF THE CROSSBOW

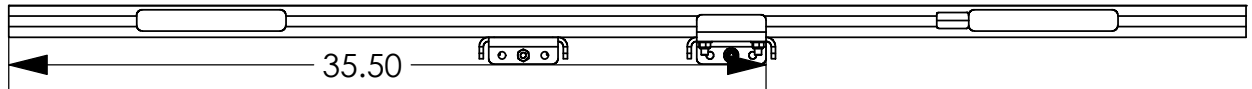

USE FAS0283, FAS0552, & 63490 (02 PLACES PER SIDE)
1/2" SOCKET

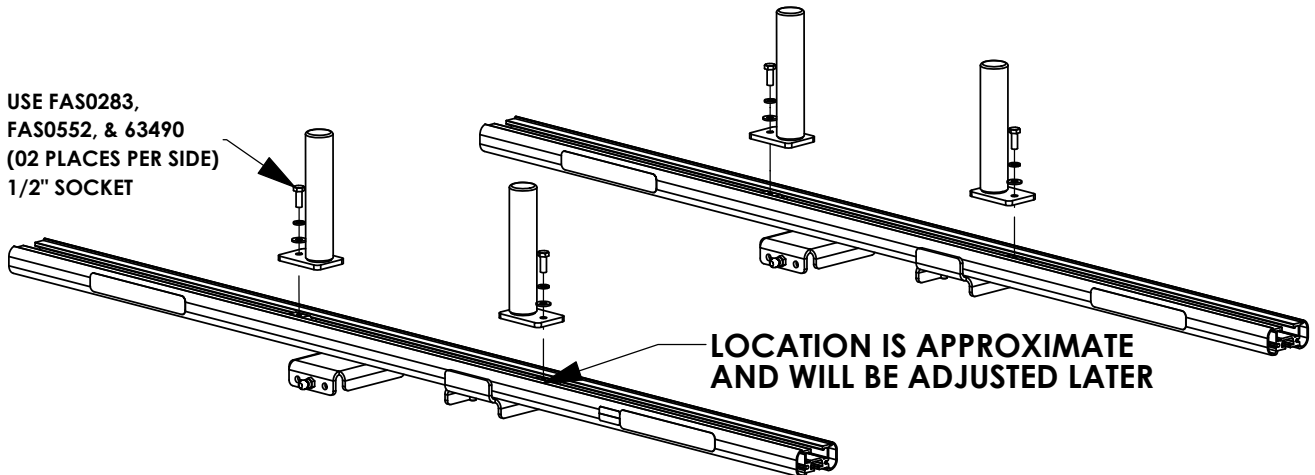

STEP 3 - INSTALL CARTRIDGES ON CROSSBOWS

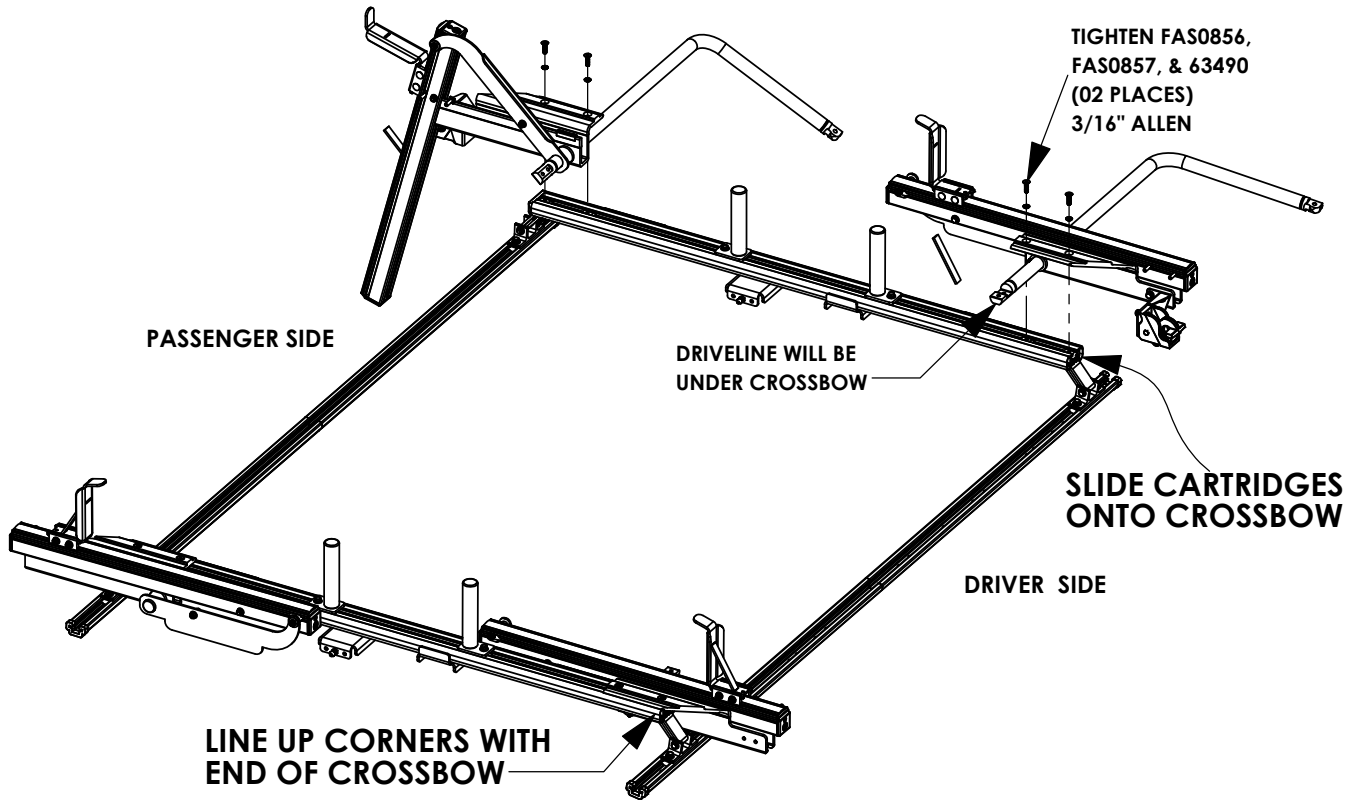

STEP 4 - INSTALL CROSSBOW END CAPS

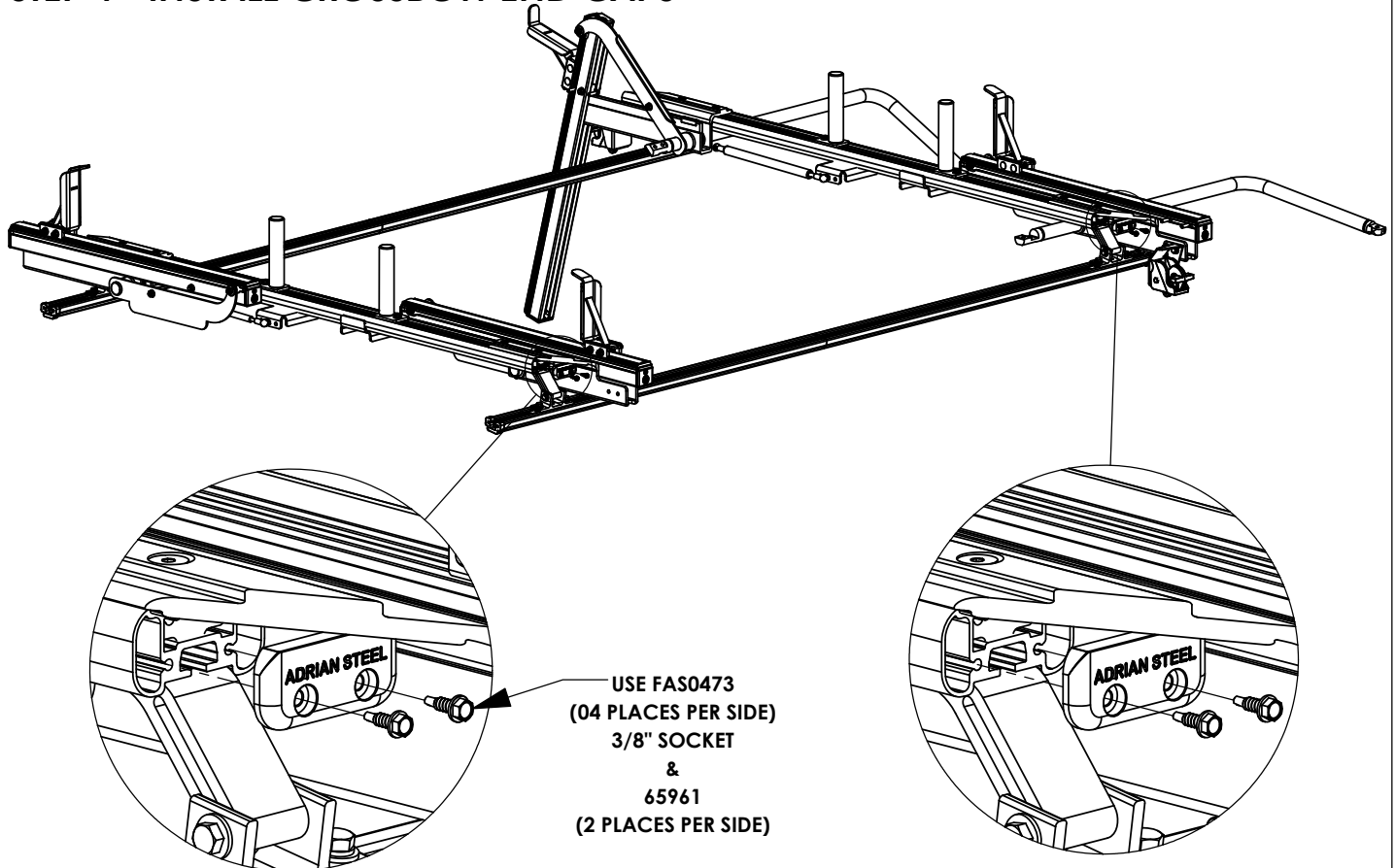

STEP 5 - INSTALL DAMPERS AND DROP DOWN HANDLE

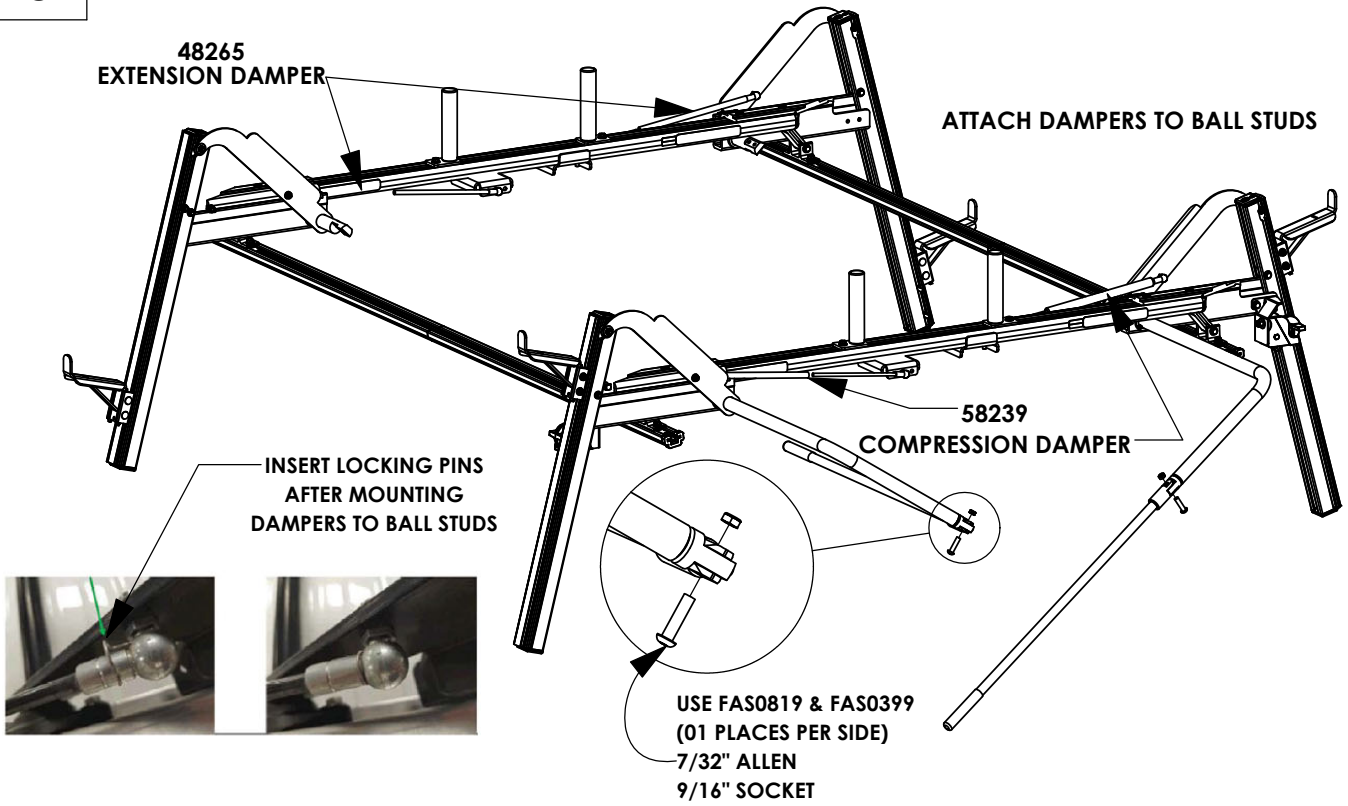

STEP 6 - INSTALL DRIVELINE AND O.S. BAR

