

INSTR. NUMBER	PG.	REV.	ITEM NO.	PART NUMBER	DESCRIPTION	QTY.
: 68558	1	A	1	68202-W	PROFILE, MOUNTING ARM, W	4
			2	63852-W	UTILITY, MOUNTING BRKT, W	4
PART NUMBER : CRMBK4W			3*	63915-W	UTILITY, CROSSBOW, 58", WHITE	2
			4*	63914	UTILITY, WEAR STRIP, 58"	2
PART : DESC. : COMPCT,MNT BKT KT,RAIL,4W			5*	63851	UTILITY RCK,END CAP,BLACK	4

ITEMS NOTED (#*) ARE PART OF: 2BARCW

NOTE: THIS INSTRUCTION IS VALID FOR THE FOLLOWING KITS:

- MOUNTING KITS**
- URMBK4W (SHOWN)
 - URMBK4B
 - URMBK2W
 - URMBK2B

- CROSSBOW KITS**
- 2BARCW (SHOWN) -1BARCW
 - 2BARCB -1BARCB
 - 2BARTOPW -1BARTOPW
 - 2BARTOPB -1BARTOPB
 - 2BARW -1BARW
 - 2BARB -1BARB

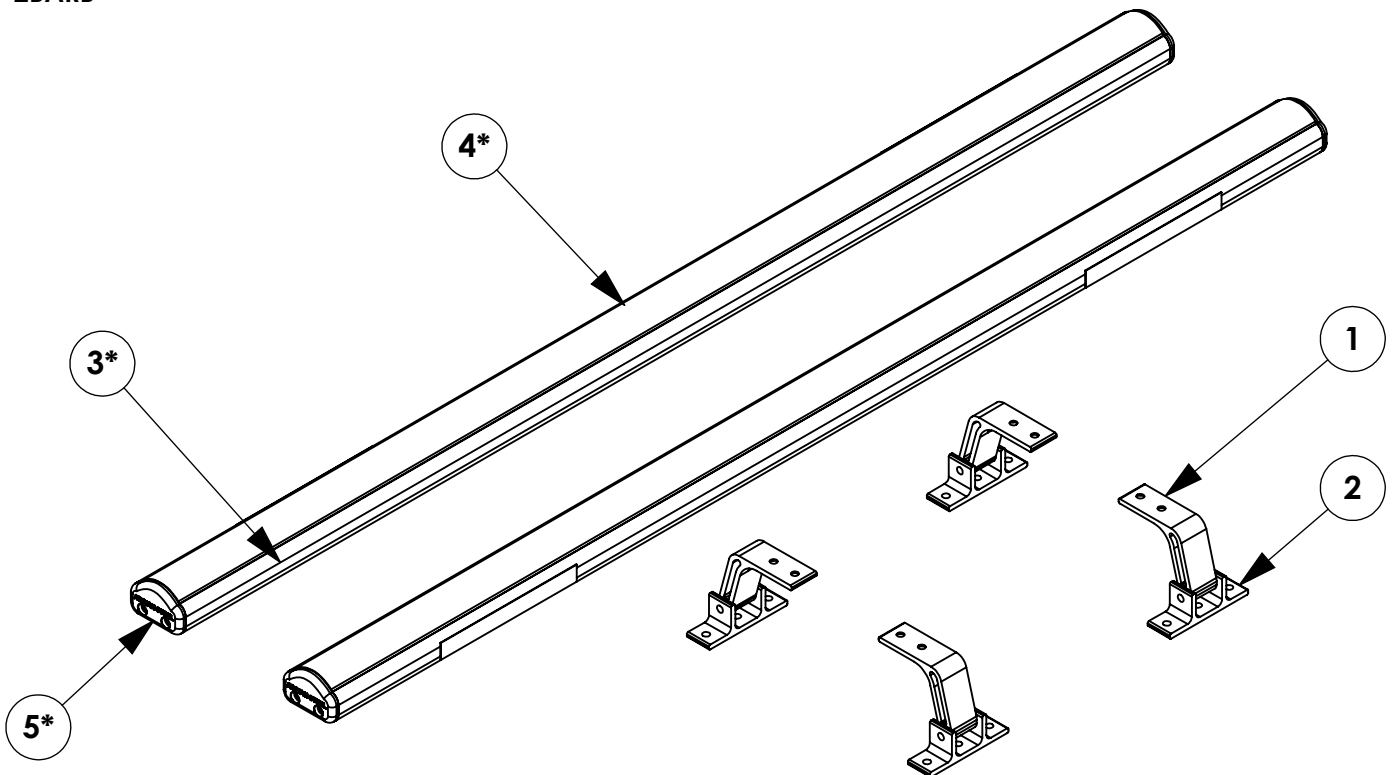

GET TO KNOW THE VEHICLE - AT THE BEGINNING OF ANY INSTALLATION, CHECK THE LOCATION OF THE FUEL TANK, FUEL LINES, BRAKE LINES, HIGH VOLTAGE BATTERIES AND WIRING HARNESES TO AVOID INJURY OR PROPERTY DAMAGE FROM TOOL CONTACT.

SEAL ALL EXTERIOR HOLES - ALL INSTALLATION HOLES SHOULD BE SEALED WITH BUTYL TAPE OR SILICON TO PREVENT WATER AND EXHAUST GASES FROM ENTERING THE VEHICLE.

CONTROL DRILL DEPTH - TO AVOID DAMAGE TO THE VEHICLE, USE A DRILL STOP OR CLEARED STEP BIT WHEN DRILLING INSTALLATION HOLES.

ALWAYS ADD PRIMER - WHEN ADDING INSTALLATION HOLES BE SURE TO USE A SELF-ETCHING PRIMER TO PREVENT CORROSION, FASTENER FAILURE AND INJURY.

MOUNTING POINTS MUST HAVE METAL-TO-METAL CONTACT - USE PROVIDED MOUNTING SPACERS TO ACCOMMODATE FOR VEHICLE FEATURES, CARPET OR SUBFLOORS.

PROVIDE CLEARANCE FOR SPACERS - IF THE INSTALLATION VEHICLE CONTAINS A CARPET OR SUBFLOOR, USE A 1-3/16" DIAMETER CARPET CUTTER (P/N: 31183-0) AT ALL MOUNTING LOCATIONS TO OPEN UP ROOM FOR SPACERS.

CHECK SPACER ORIENTATION - BE SURE THAT THE INDENT IN THE SPACER COVERS THE PLUSNUT HEAD; THIS ENSURES THE MOST METAL-TO-METAL CONTACT AND REDUCES VIBRATION.

PLUSNUT INSTALLATION - A PLUSNUT GUN IS RECOMMENDED FOR PLUSNUT INSTALLATION FOR ITS PRODUCTION SPEED. HOWEVER, A PLUSNUT SETTING TOOL CAN ALSO BE USED (P/N: 22200-0).

THRU-BOLT CLEARANCE - WHEN USING A THRU-BOLT AT ANY MOUNTING LOCATION, BE SURE THAT YOUR HOLE HAS 1/16" CLEARANCE.

FASTENERS USED

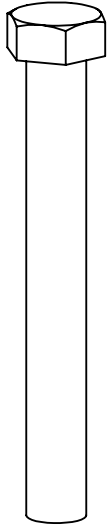

FAS0243
5/16-18 X 2.5 SS
HH SCREW
QTY: 4



FAS0552
5/16 SS
FLAT WASHER
QTY: 12



FAS0588
5/16 SS
SPLIT WASHER
QTY: 8

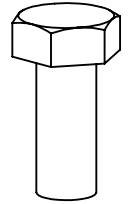

FAS0799
5/16-18 X .75 SS
HH SCREW
QTY: 8



FAS0857
5/16 SS
CS EXT LCK WASHER
QTY: 8

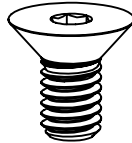

FAS0858
5/16-18 X .625 SS
FHH CS SCREW
QTY: 8

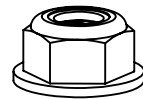

FAS0861
5/16-18 SS
NLK HFLNG NUT
QTY: 4

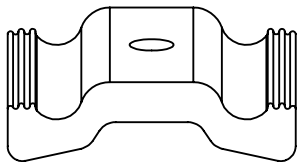

35335-0
1.5" AD RAIL
QTY: 8

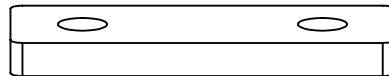

68042
PROFILE FOOT MTG PLATE
QTY: 4

BEGIN ASSEMBLY

STEP 1 - ASSEMBLE MOUNTING ARMS TO CROSSBOW

(2) FAS0857, (2) FAS0858
68042
(2 PLACES PER CROSSBOW)
LOOSE INSTALL

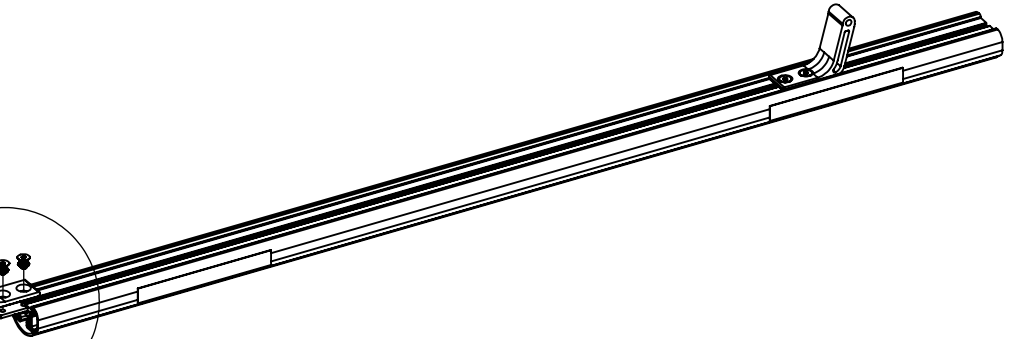
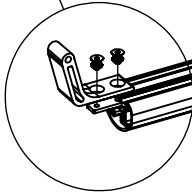
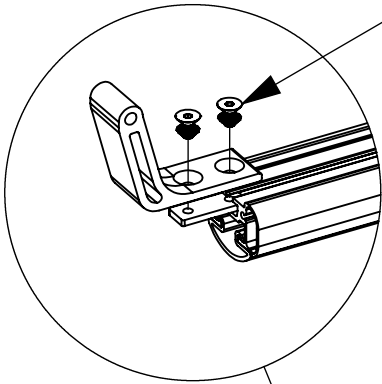

STEP 2 - ASSEMBLE MOUNTING BRACKETS TO MOUNTING ARMS

FAS0243, FAS0552, FAS0861
(2 PLACES PER CROSSBOW)
LOOSE INSTALL

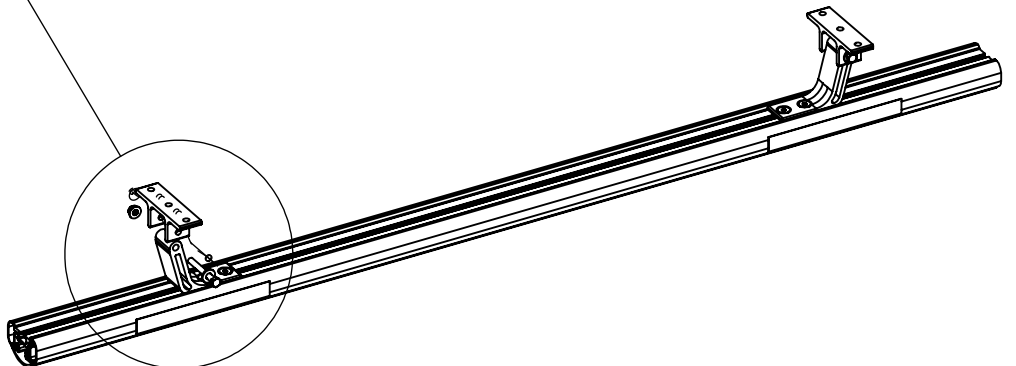
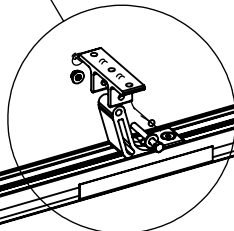
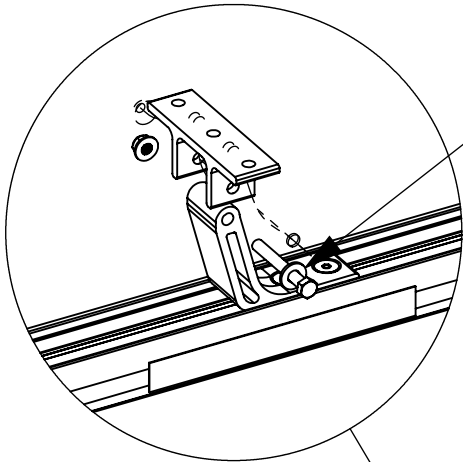

BEGIN INSTALLATION

STEP 3 - INSTALL MOUNTING BRACKET TO RAIL

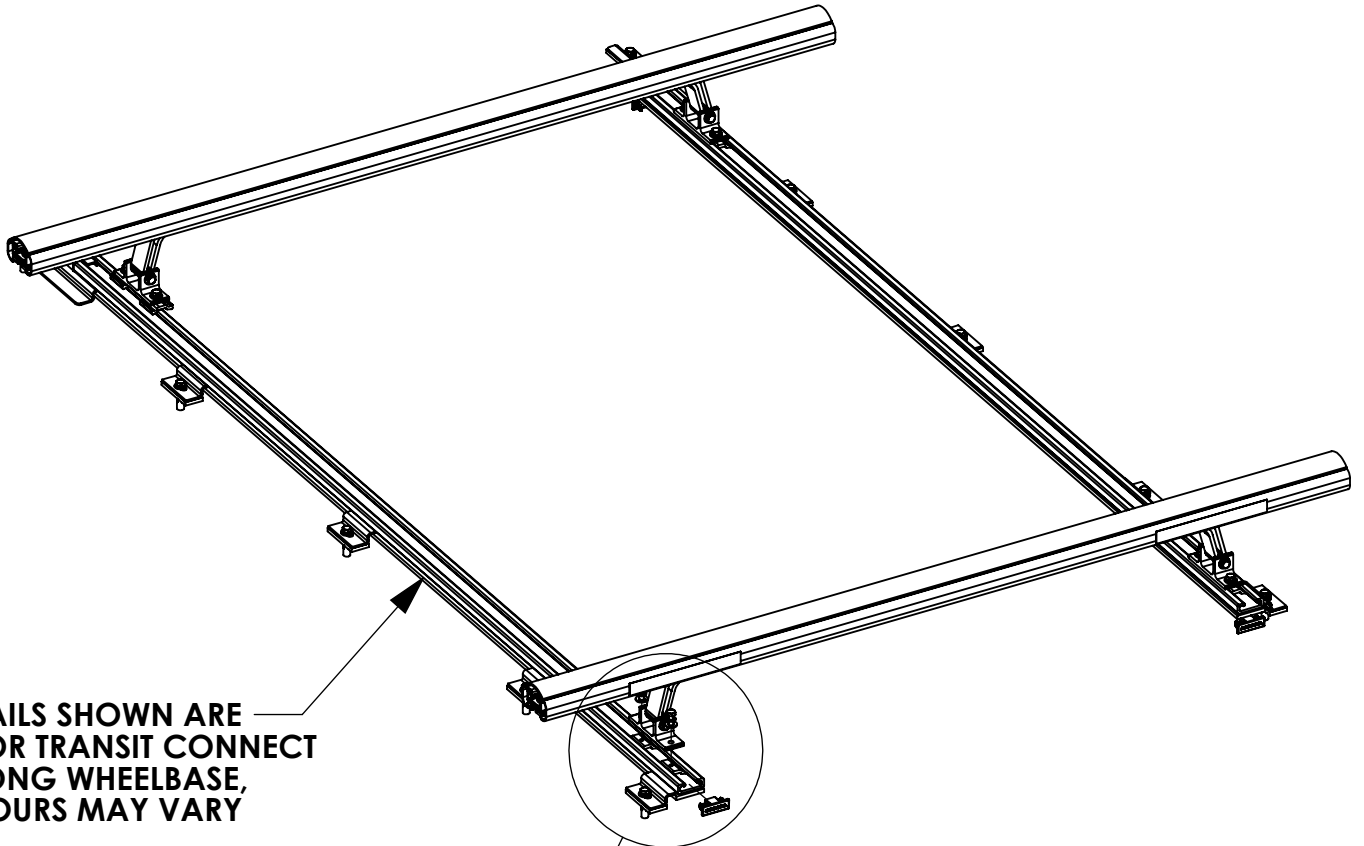

RAILS SHOWN ARE FOR TRANSIT CONNECT LONG WHEELBASE, YOURS MAY VARY

FAS0799, FAS0588, FAS0552, 35335-0 (4 PLACES PER CROSSBOW) 1/2 SOCKET

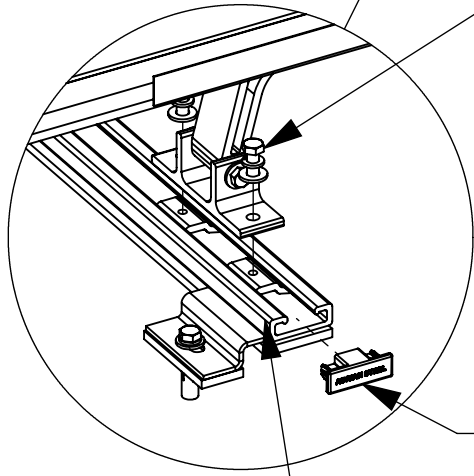

AFTER MOUNTING BRACKET KIT IS IN, ADD END CAP TO RAIL

DISTANCE OFF OF THE REAR IS PROVIDED IN YOUR SPECIFIC ACCESSORY INSTALLATION INSTRUCTIONS.

STEP 4 - CENTER CROSSBOW AND SECURE

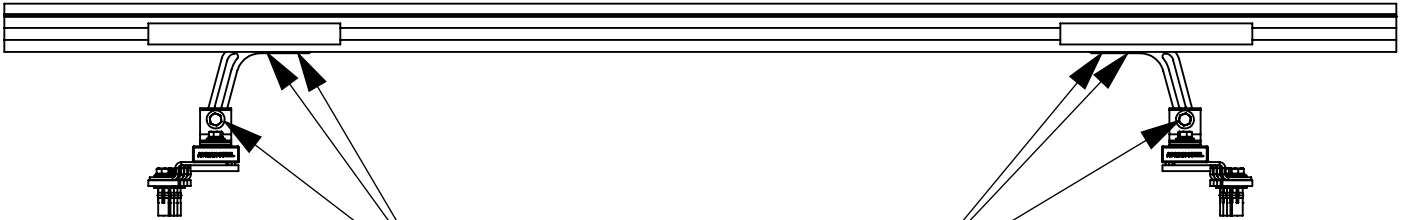

**CENTER CROSSBOW AND
SECURE MOUNTING BRACKETS
(6 PLACES PER CROSSBOW)
1/2 SOCKET
1/2 WRENCH
5/32 ALLEN**

INSTR. NUMBER : **69484**

PG: **1** REV: **A**

PART NUMBER • **Standard Drop ProLift**
• **Low & Compact Vans**

PART DESC. • ProLift Adjustment Instructions -
• **Standard Drop**
• **Low Roof & Compact Vans**

Step 3: With 1/2" Socket loosen nut, slide post so that it is snug against the ladder. Tighten nut

Step 1: With 1/2" Socket loosen nut, slide post so that it is snug against the ladder. Tighten nut

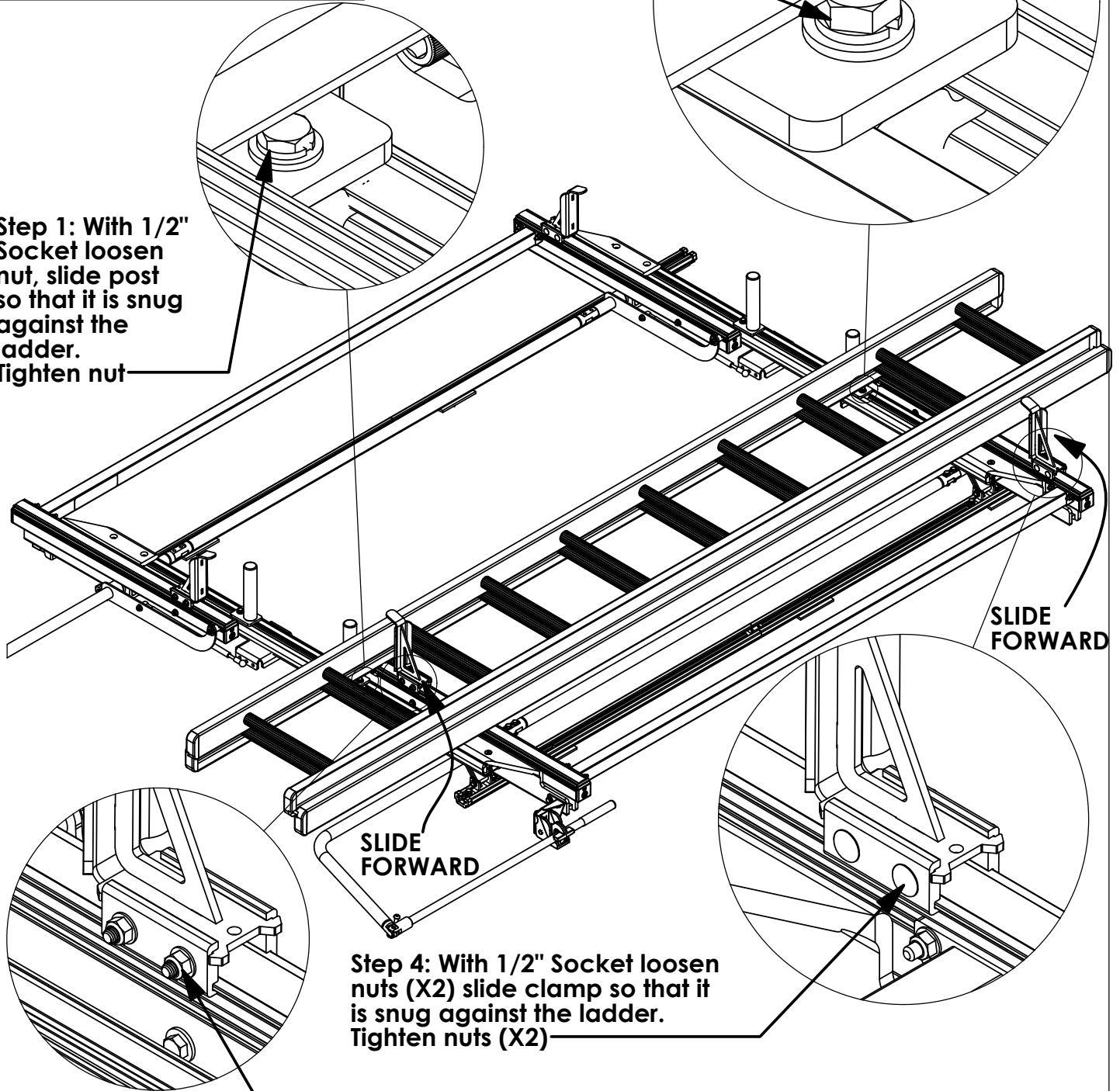

SLIDE FORWARD

SLIDE FORWARD

Step 4: With 1/2" Socket loosen nuts (X2) slide clamp so that it is snug against the ladder. Tighten nuts (X2)

Step 2: With 1/2" Socket loosen nuts (X2) slide clamp so that it is snug against the ladder. Tighten nuts (X2)

Once all brackets are adjusted operate rack to make sure clamps are not too tight

INSTR. NUMBER	PG:	REV:	ITEM NO.	PART NUMBER	DESCRIPTION	PLSDPSC	PLSDDSC
: 68581	1	B	1	68418-W	PROLIFT, CP, PS RR CRT, W	1	-
			2	68414-B	PROLIFT, CP, PS DLINE WLD, BLK	1	-
PART NUMBER • PLSDDSC & PLSDPSC			3	68412-W	PROLIFT, CP, OS BAR WLD, BLK	1	1
			4	68435-B	PROLIFT, CP, OS BAR WLD, WHITE	1	1
PART • PROLIFT,STD,DS,CPT & DESC. • PROLIFT,STD,PS,CPT			5	68031-W	DROP DOWN FRONT ARM ASSM PS, WHITE	1	-
			6	68045-W	PROLIFT DAMPER MOUNT, WHITE	2	2
			7	68180-W	DROP DOWN LATCH BRACKET, WHITE	1	1
			8	25340-0	HANDLE LATCH-STD	1	1
			9	58239	COMPRESSION DAMPER	1	1
			10	68628-W	PROLIFT,HR,DAMPER BRKT, W	2	2
			11	68422-W	PROLIFFT, CP, DS RR CRT, WHITE	-	1
			12	68419-B	PROLIFT, CP, DS DLINE WLD, BLK	-	1
			13	68013-W	DROP DOWN FRONT ARM ASM DS, WHITE	-	1

- PART NUMBERS WITH "-W" SUFFIX ARE PAINTED WHITE
- FOR BLACK MOUNTING KITS, REPLACE "-W" PARTS WITH "-B" PARTS

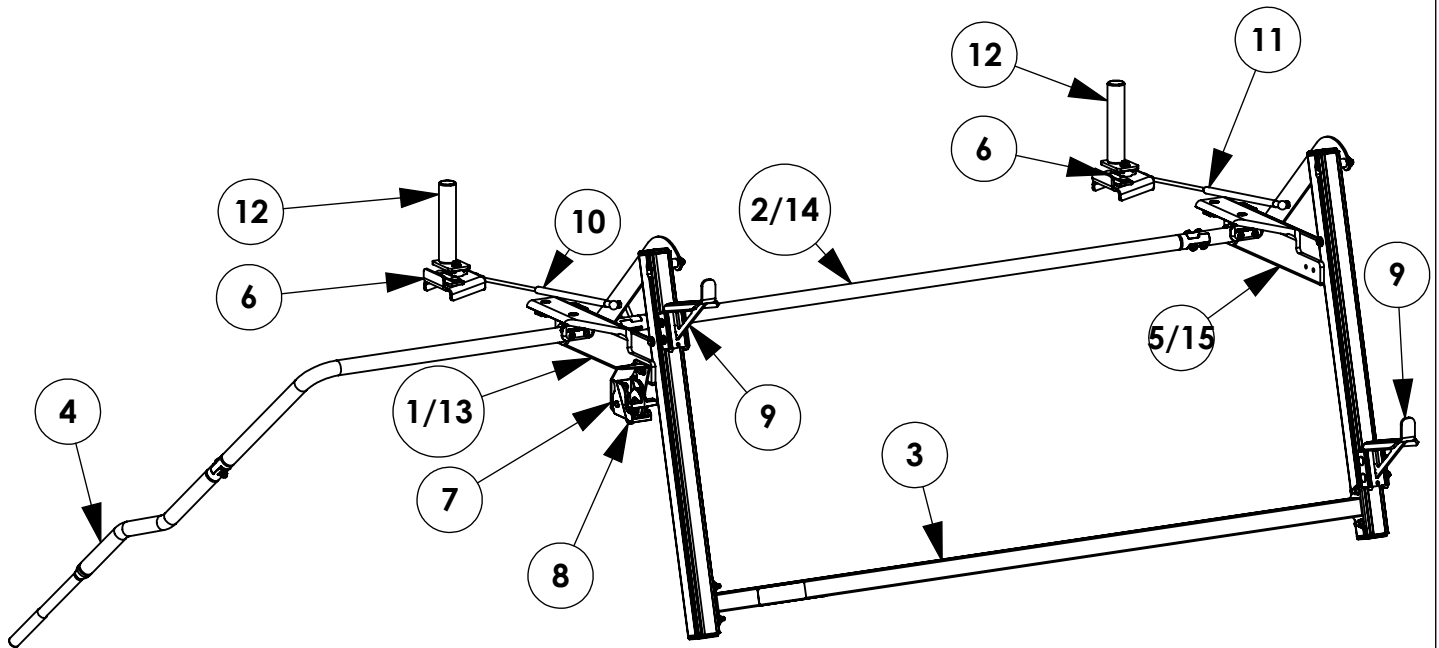

- TOOLS NEEDED:**
- 1/2" SOCKET
 - 1/2" WRENCH
 - 9/16" SOCKET
 - 3/8" SOCKET
 - DRIVE RATCHET
 - 7/32" ALLEN WRENCH
 - 3/16" ALLEN WRENCH
 - 13mm WRENCH
 - TAPE MEASURE
 - RUBBER Mallet
 - IMPACT DRIVER

****IF BUILDING A DUAL SIDED RACK BUILD BOTH SIDES IN PARALLEL FOR EACH STEP. IF BUILDING SINGLE SIDED REFERENCE ONLY THAT SIDE WHEN BUILDING.****

GET TO KNOW THE VEHICLE - AT THE BEGINNING OF ANY INSTALLATION, CHECK THE LOCATION OF THE FUEL TANK, FUEL LINES, BRAKE LINES, HIGH VOLTAGE BATTERIES AND WIRING HARNESES TO AVOID INJURY OR PROPERTY DAMAGE FROM TOOL CONTACT.

SEAL ALL EXTERIOR HOLES - ALL INSTALLATION HOLES SHOULD BE SEALED WITH BUTYL TAPE OR SILICON TO PREVENT WATER AND EXHAUST GASES FROM ENTERING THE VEHICLE.

CONTROL DRILL DEPTH - TO AVOID DAMAGE TO THE VEHICLE, USE A DRILL STOP OR CLEARED STEP BIT WHEN DRILLING INSTALLATION HOLES.

ALWAYS ADD PRIMER - WHEN ADDING INSTALLATION HOLES BE SURE TO USE A SELF-ETCHING PRIMER TO PREVENT CORROSION, FASTENER FAILURE AND INJURY.

MOUNTING POINTS MUST HAVE METAL-TO-METAL CONTACT - USE PROVIDED MOUNTING SPACERS TO ACCOMMODATE FOR VEHICLE FEATURES, CARPET OR SUBFLOORS.

PROVIDE CLEARANCE FOR SPACERS - IF THE INSTALLATION VEHICLE CONTAINS A CARPET OR SUBFLOOR, USE A 1-3/16" DIAMETER CARPET CUTTER (P/N: 31183-0) AT ALL MOUNTING LOCATIONS TO OPEN UP ROOM FOR SPACERS.

CHECK SPACER ORIENTATION - BE SURE THAT THE INDENT IN THE SPACER COVERS THE PLUSNUT HEAD; THIS ENSURES THE MOST METAL-TO-METAL CONTACT AND REDUCES VIBRATION.

PLUSNUT INSTALLATION - A PLUSNUT GUN IS RECOMMENDED FOR PLUSNUT INSTALLATION FOR ITS PRODUCTION SPEED. HOWEVER, A PLUSNUT SETTING TOOL CAN ALSO BE USED (P/N: 22200-0).

THRU-BOLT CLEARANCE - WHEN USING A THRU-BOLT AT ANY MOUNTING LOCATION, BE SURE THAT YOUR HOLE HAS 1/16" CLEARANCE.

FASTENERS AND HARDWARE USED
BAG REFERENCE: BAG68181 & BAG68182

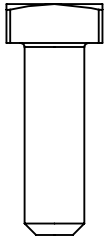

FAS0035
5/16-18 X 1.0
SQ HD, BOLT
QTY: 4

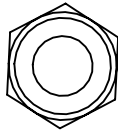

FAS0110
3/8-19
NYL HEX NUT
QTY: 1

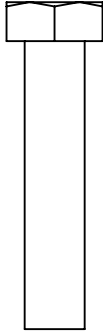

FAS0242
5/16-18 X 1.5
HH SCREW
QTY: 4

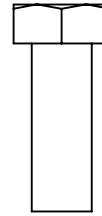

FAS0283
5/16-18 X .875
HH SCREW
QTY: 2

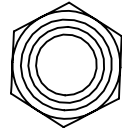

FAS0399
3/8-16
NYL HEX NUT
QTY: 1

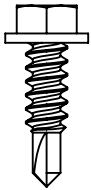

FAS0473
#12 X .75
HH TEK SCREW
QTY: 4

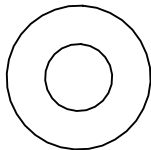

FAS0552
5/16
FLAT WASHER
QTY: 8

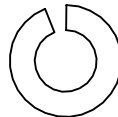

FAS0588
5/16
SPLIT WASHER
QTY: 4

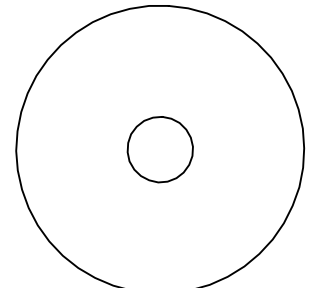

DISCARD FAS0603
5/16 X 1.5 OD
FENDER WASHER
QTY: 2

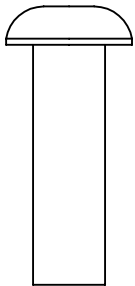

FAS0701
3/8-16 X 1.25
BHC SCREW
QTY: 1

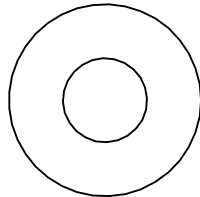

FAS0720
3/8
FLAT WASHER
QTY: 1

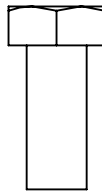

FAS0799
5/16-18 X .75
HH SCREW
QTY: 2

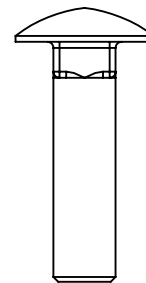

FAS0812
5/16-18 X 1.25
CRG BOLT
QTY: 4

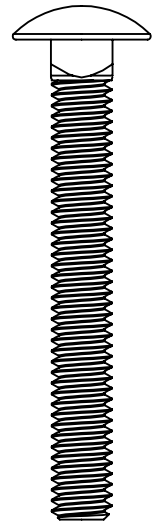

FAS0838
5/16-18 X 2.5
CRG BOLT
QTY: 4

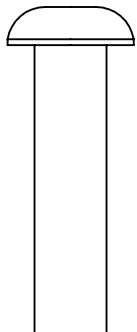

FAS0819
3/8-16 X 1.5
BHC SCREW
QTY: 1

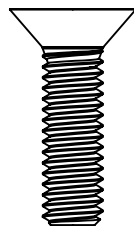

FAS0856
5/16-18 X 1.125
FHH SCREW
QTY: 4

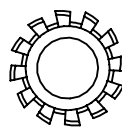

FAS0857
5/16 CS
LCK EXT WASHER
QTY: 4

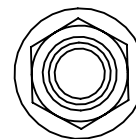

FAS0861
5/16-18
NYL HEX NUT
QTY: 18

INTENTIONALLY LEFT BLANK

FASTENERS AND HARDWARE USED

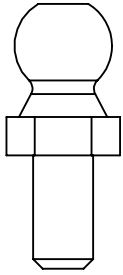

34927-0
5/16-18 X 13mm
BALL STUD
QTY: 2

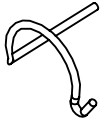

34928-0
13mm RETAINER
SPRING CLIP
QTY: 4



64830
BOLT PLATE
REAR ROLLER
QTY: 2

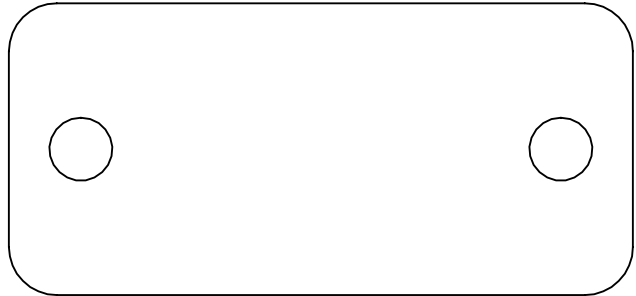

64831
SPACER
REAR ROLLER
QTY: 2

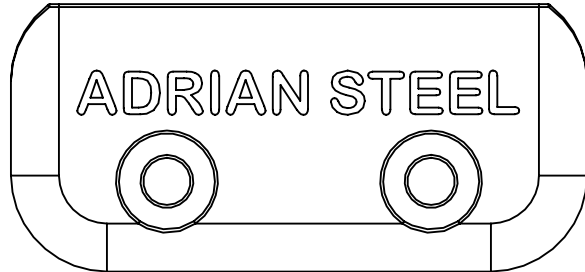

65961
DROP DOWN
END CAP
QTY: 2

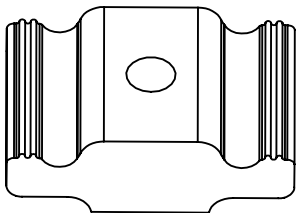

63490
1" RAIL SLIDE
QTY: 6

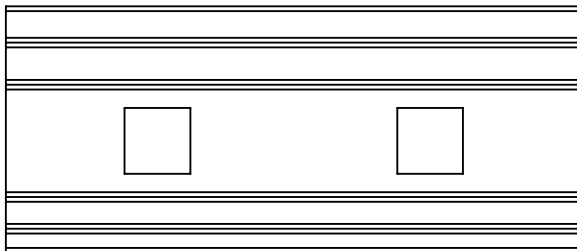

65963-W
STOP CLAMP
WHITE
QTY: 4

INTENTIONALLY LEFT BLANK

STEP 1 - MOUNT DAMPER BRACKETS

Step 1.1
FULLY TIGHTEN
34927-0 & FAS0861
(02 PLACES PER
SIDE)
13mm WRENCH
1/2" SOCKET

STEP 1.2
FULLY TIGHTEN
(02) FAS0812,
64830, 64831, &
(02) FAS0861
(02 PLACES PER
SIDE)
1/2" SOCKET

A.2

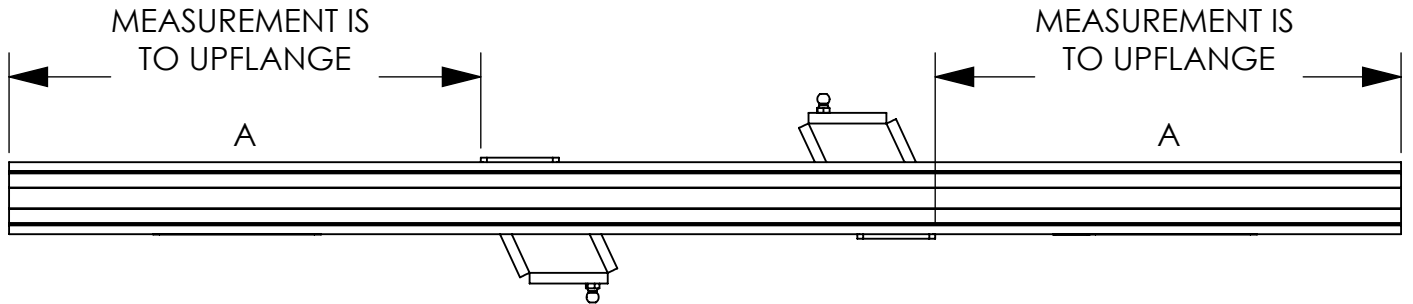
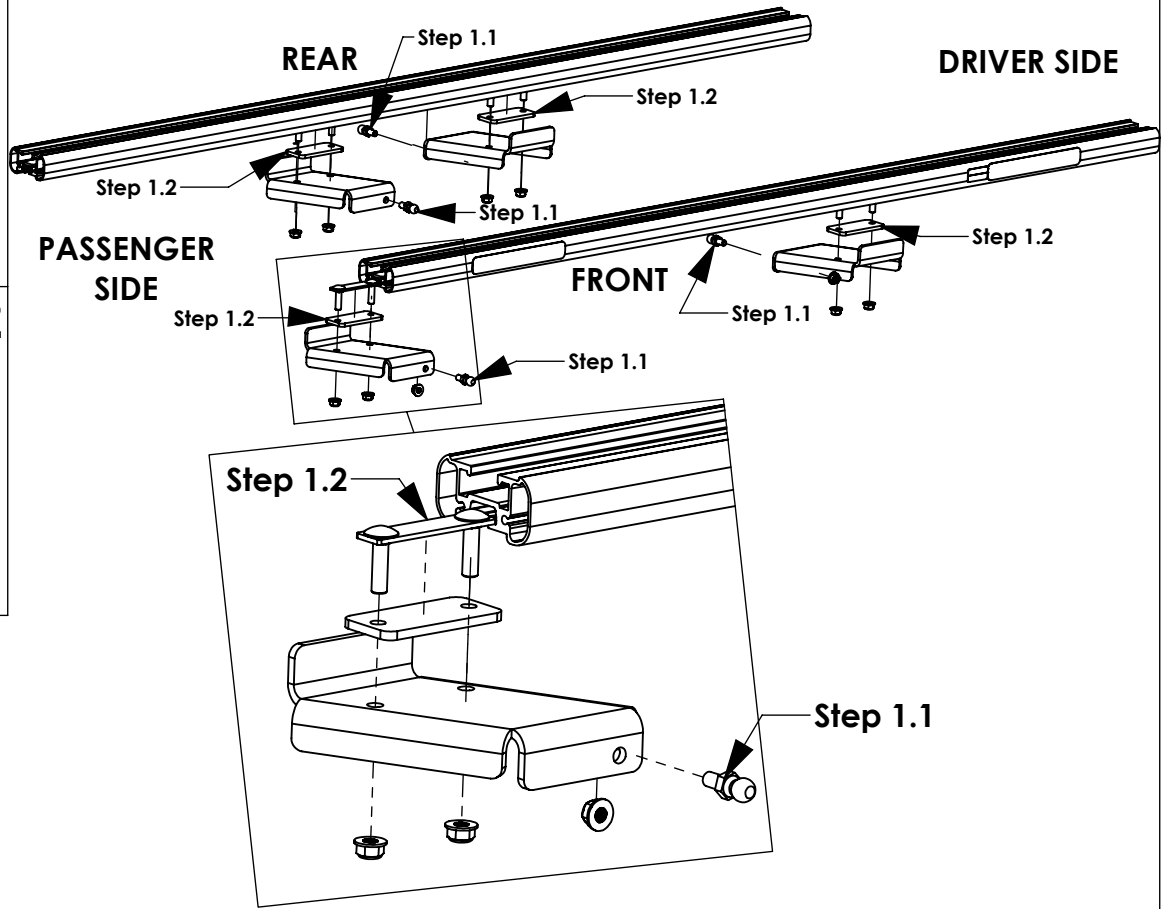

REFER TO BELOW TABLE FOR DISTANCE FROM END OF CROSSBOW



TABLE: 68581-1

VEHICLE	TRANSIT CONNECT LONG WB	TRANSIT CONNECT SHORT WB	PROMASTER CITY	MERCEDES METRIS LONG WB	MERCEDES METRIS SHORT WB
MEASUREMENT "A"	19 5/8"	19 5/8"	19 5/8"	19 5/8"	19 5/8"
CROSSBOW TYPE	48" CROSSBOW	48" CROSSBOW	58" CROSSBOW	58" CROSSBOW	58" CROSSBOW

STEP 2 - MOUNT INNER STOPS TO CROSSBOW

Step 2.1
FAS0283,
FAS0552,
FAS0861
(2 PLACES PER
SIDE)
1/2" SOCKET

B.1

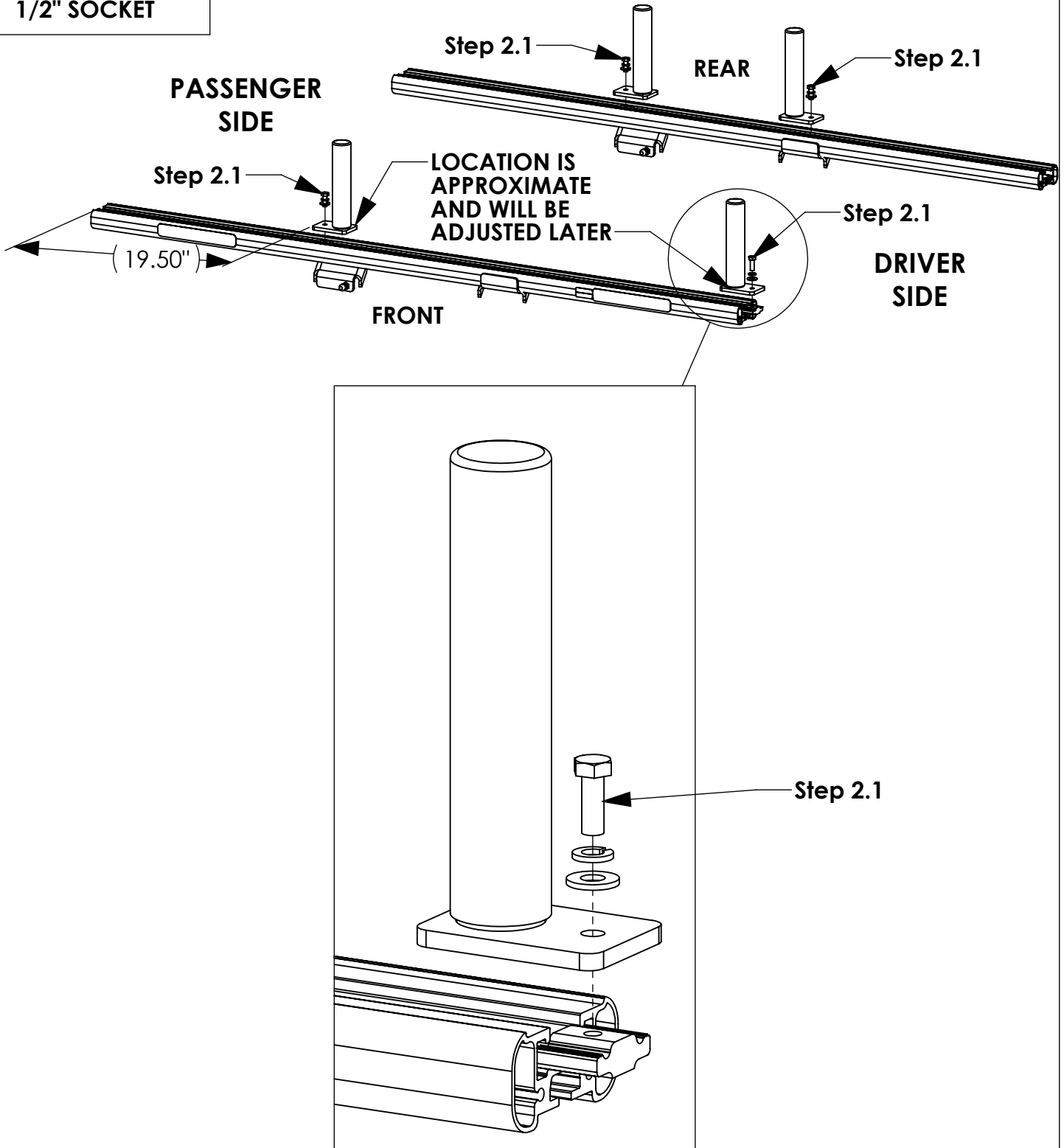

STEP 3 - INSTALL CLAMPS AND HARDWARE ON DROP DOWN CARTRIDGES

REAR SUB-ASSEMBLY

PASSENGER SIDE
68418-W

STEP 3.1
FULLY TIGHTEN
FAS0838 &
FAS0861
(02 PLACES)
1/2" SOCKET

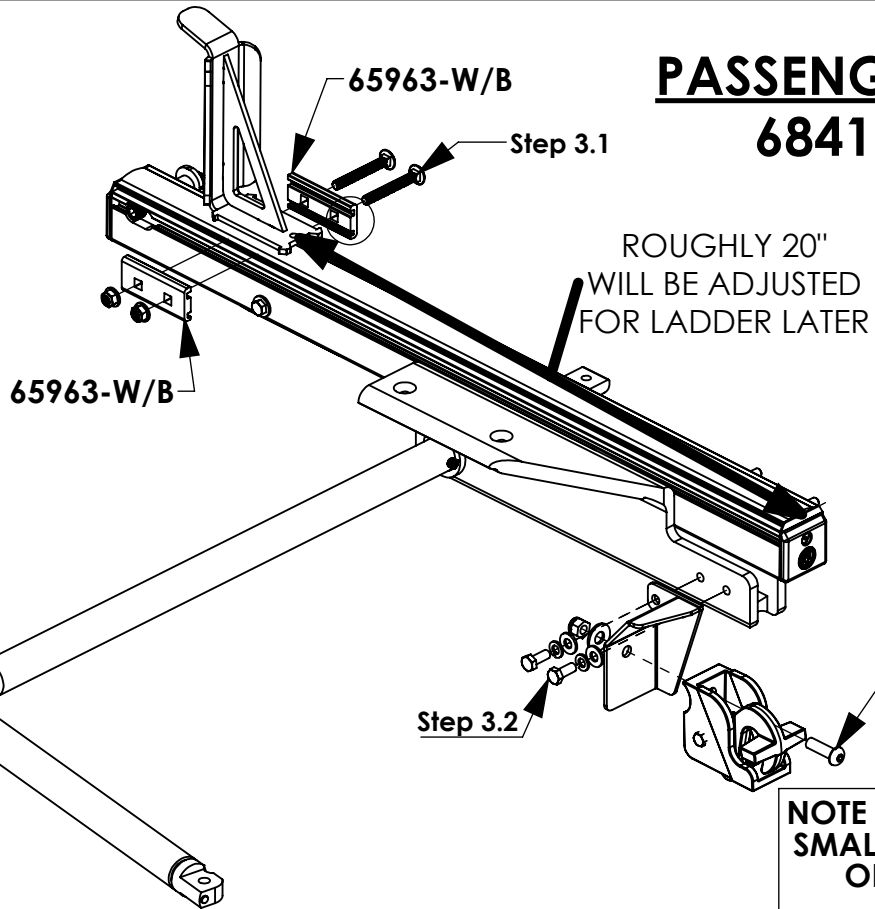

STEP 3.2
FULLY TIGHTEN
FAS0799,
FAS0552, &
FAS0588
(02 PLACES)
1/2" SOCKET

NOTE ORIENTATION:
SMALLER CHANNEL
ON BOTTOM

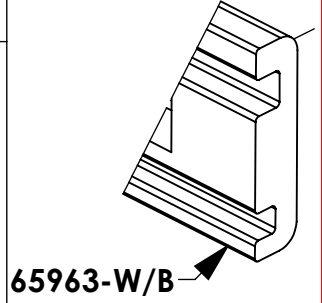

DRIVER SIDE
68422-W

STEP 3.3
FULLY TIGHTEN
FAS0701, FAS0720,
& FAS0110
(01 PLACE)
7/32" ALLEN
9/16" SOCKET

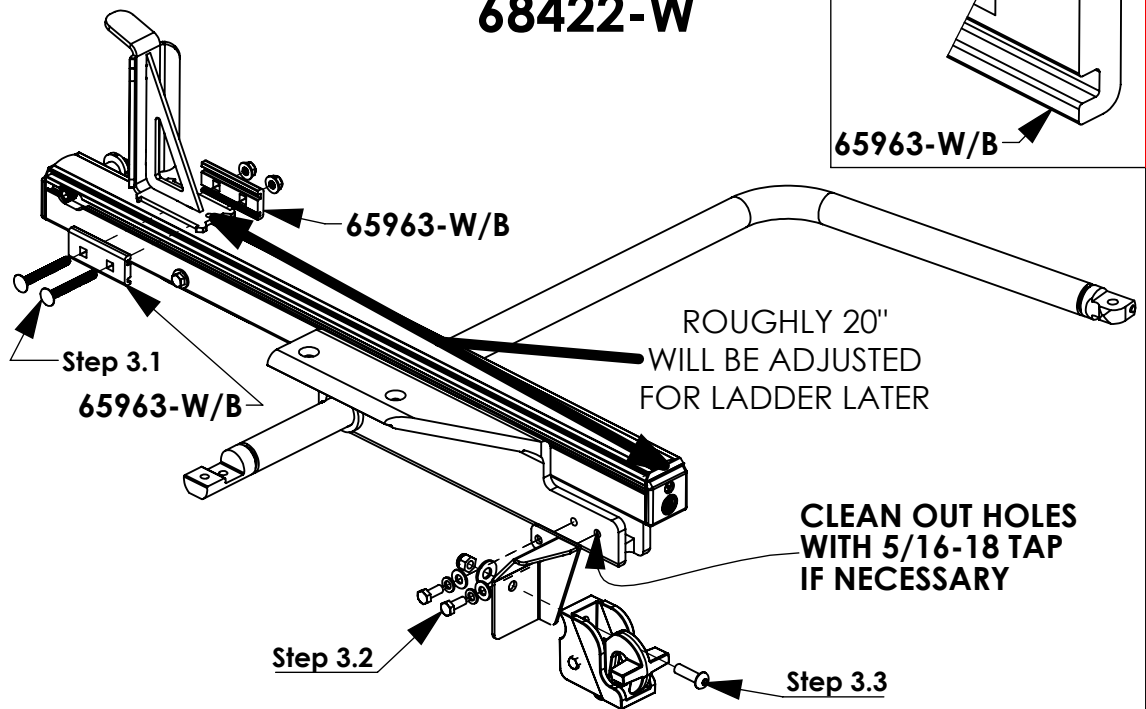

STEP 3 - INSTALL CLAMPS AND HARDWARE ON DROP DOWN CARTRIDGES

FRONT SUB-ASSEMBLY

STEP 3.4
FULLY TIGHTEN
FAS0838 &
FAS0861
(02 PLACES)
1/2" SOCKET

STEP 3.5
FAS0035
SLIDE INTO SLOT
(02 PLACES)

PASSENGER SIDE
68031-W

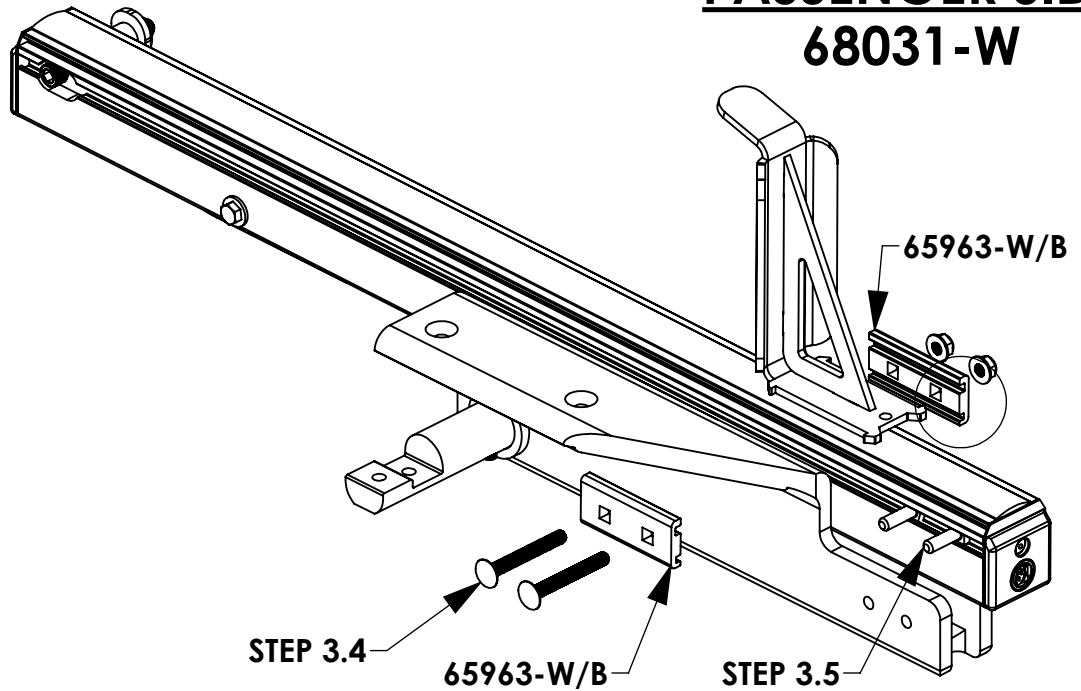

NOTE ORIENTATION:
SMALLER CHANNEL
ON BOTTOM

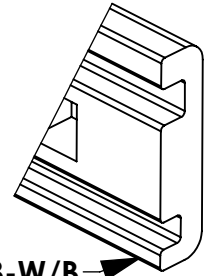

DRIVER SIDE
68013-W

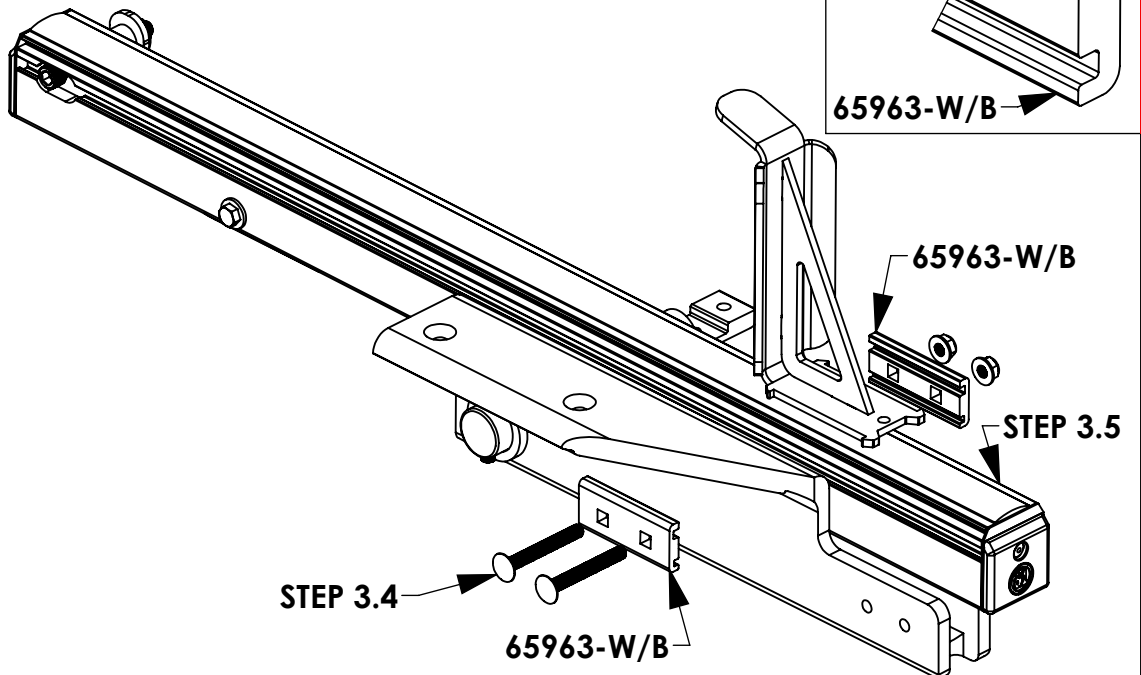



**REFERENCE INSTALLATION GUIDE 68895 TABLES 1-3
INSTALLATION OF A.1, A.2, B.1, & B.2 SHOULD BE
COMPLETE BEFORE PROCEEDING TO STEP 4**

STEP 4 - INSTALL CARTRIDGES ON CROSSBOWS

STEP 4.1
SLIDE 63490 INTO
END OF
CROSSBOWS

C.1

STEP 4.2
LINE UP CORNERS
WITH END OF
CROSSBOW

STEP 4.3
FULLY TIGHTEN
(02) FAS0856,
(02) FAS0857, &
(02) 63490
(02 PLACES PER
SIDE)
3/16" ALLEN

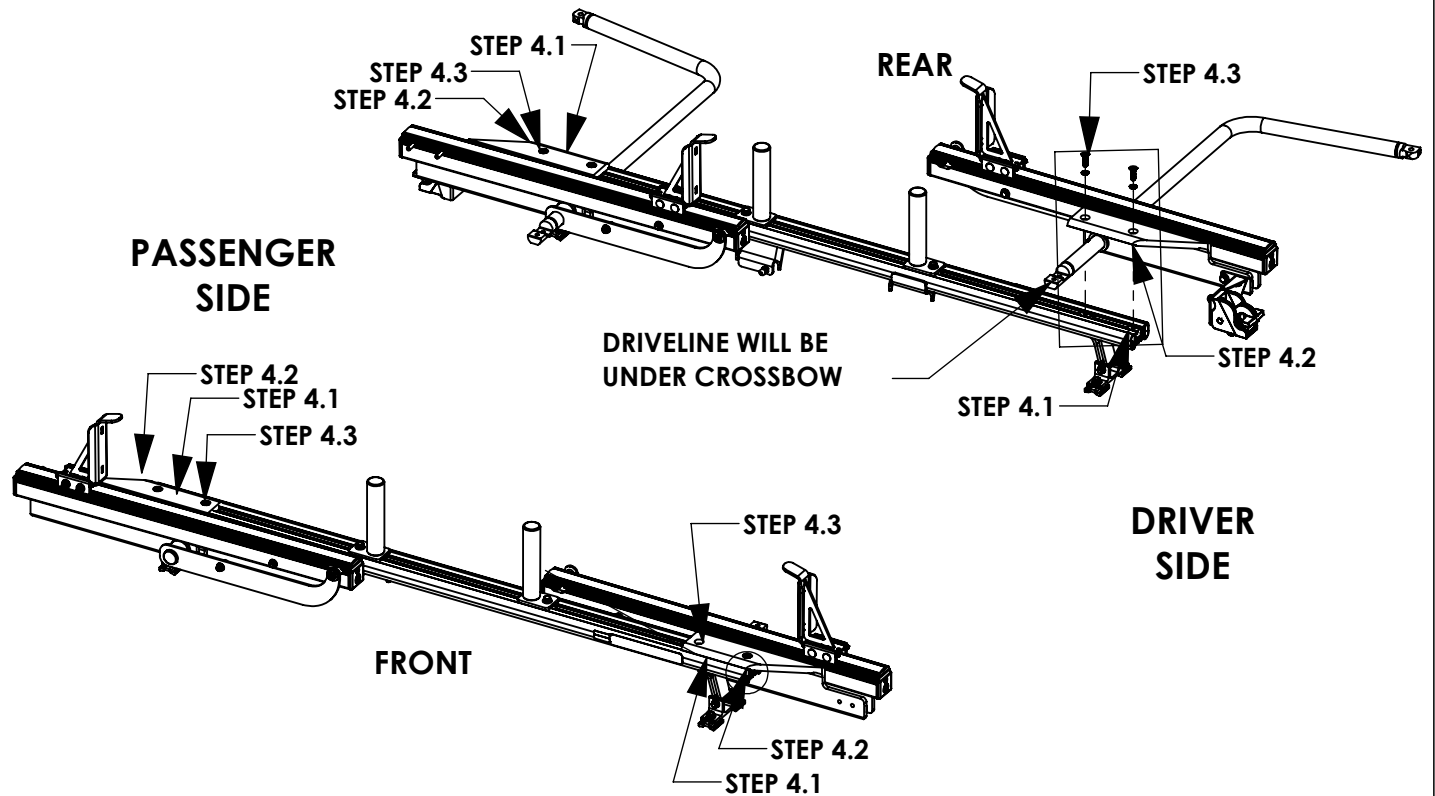
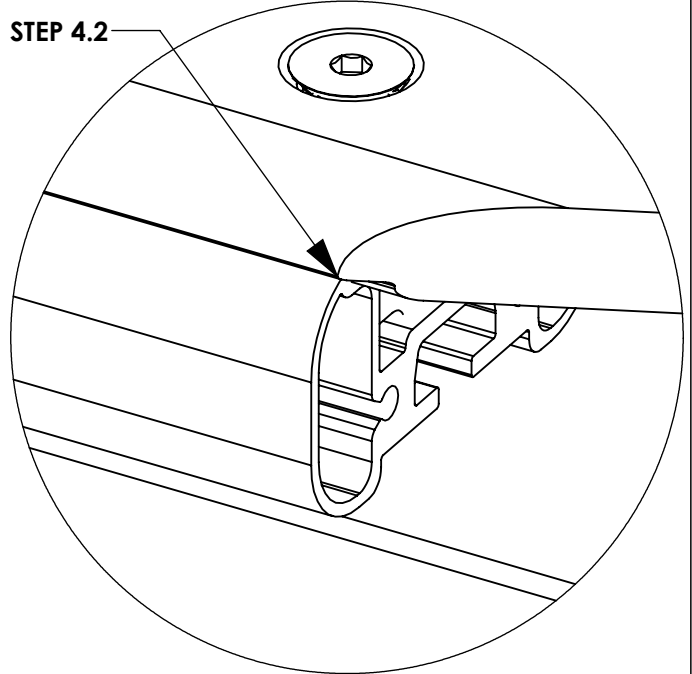
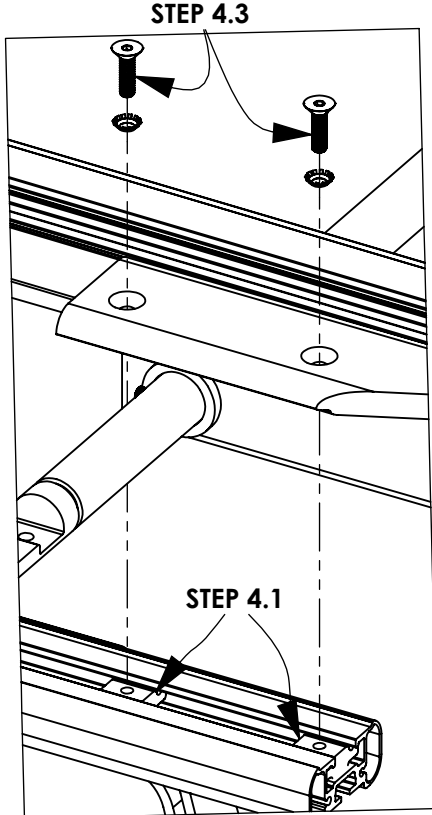

STEP 5 - INSTALL DRIVELINE

STEP 5.1
FULLY TIGHTEN
FAS0242, FAS0552
& FAS0861
(04 PLACES PER
SIDE)
1/2" WRENCH
1/2" SOCKET

BEST PRACTICE:
WHEN INSTALLING
BOLTS OPEN RACK
ROUGHLY 45
DEGREES FOR
EASIER ACCESS &
INSTALLATION

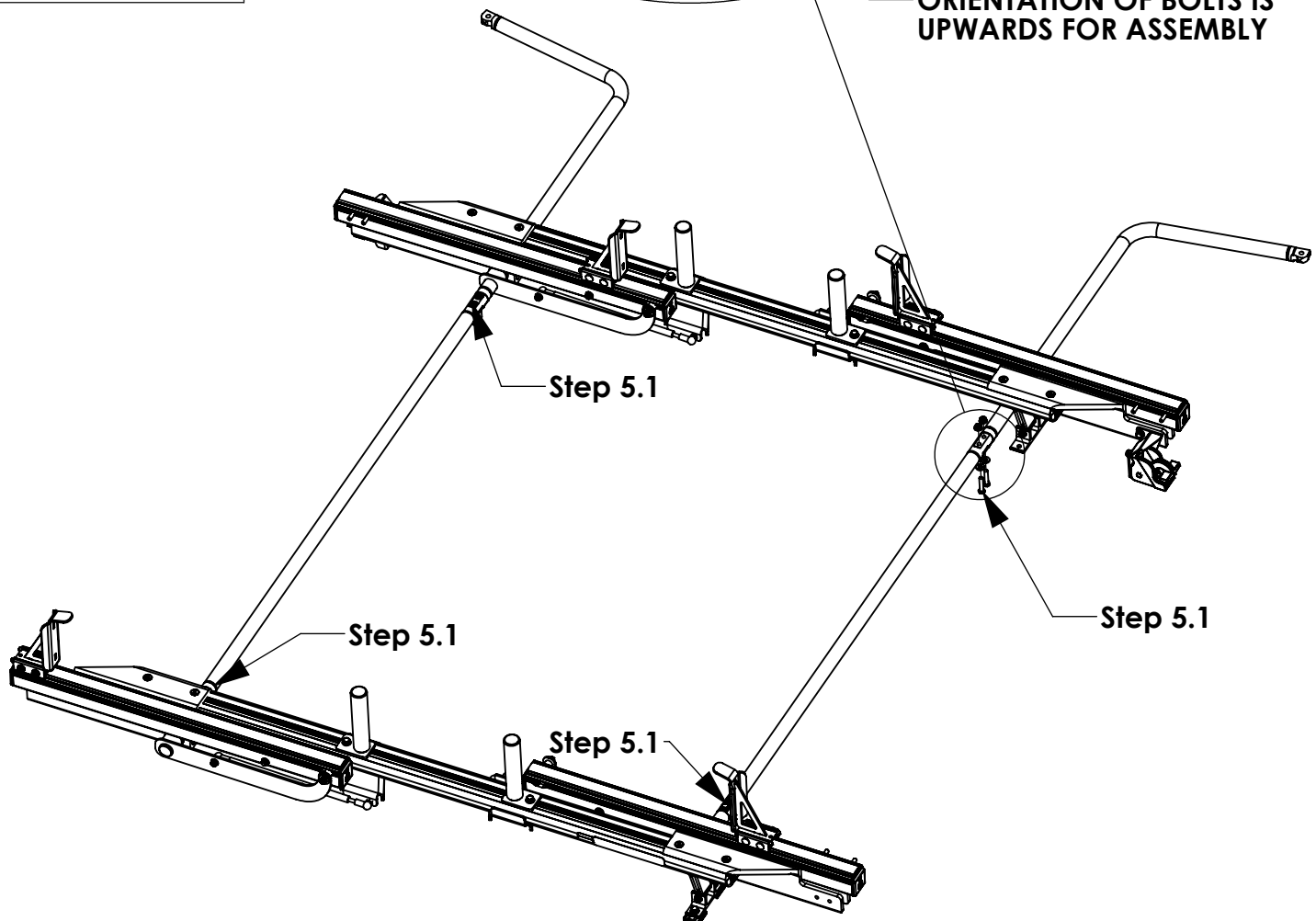
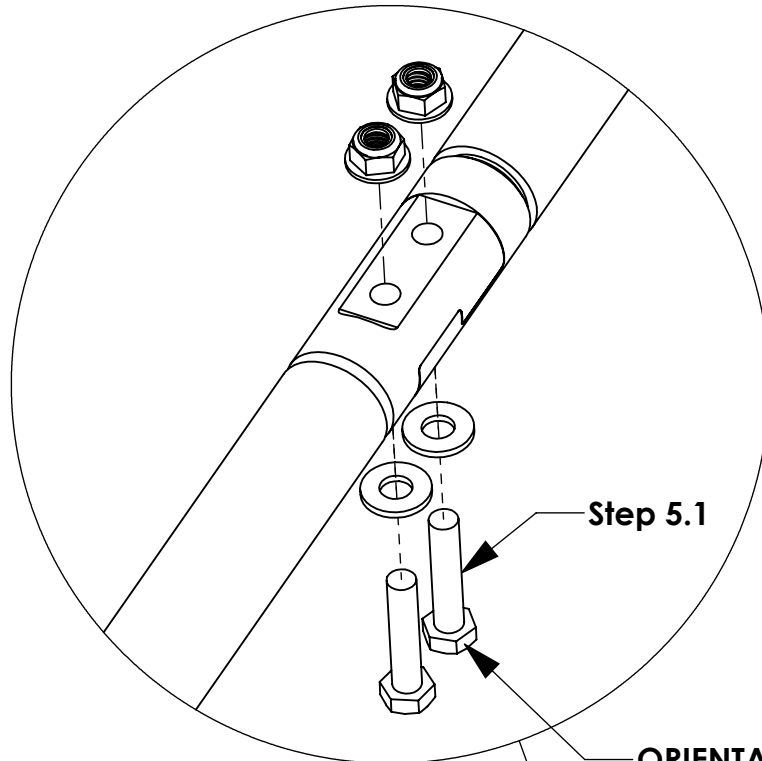

STEP 6 - DEPLOY RACK & INSTALL DAMPERS AND DROP DOWN HANDLE

Step 6.1
 ATTACH EXTENSION
 DAMPERS (48625) TO
 BALL STUDS.
ORIENTATION OF
 DAMPER MATTERS!!!
 (01 PLACE PER SIDE)

Step 6.2
 ATTACH
 COMPRESSION
 DAMPERS (58239) TO
 BALL STUDS.
ORIENTATION OF
 DAMPER MATTERS!!!
 (01 PLACE PER SIDE)

Step 6.3
 INSERT LOCKING
 PINS (34928-0)
 AFTER MOUNTING
 DAMPERS TO BALL
 STUDS
 (04 PLACES PER SIDE)

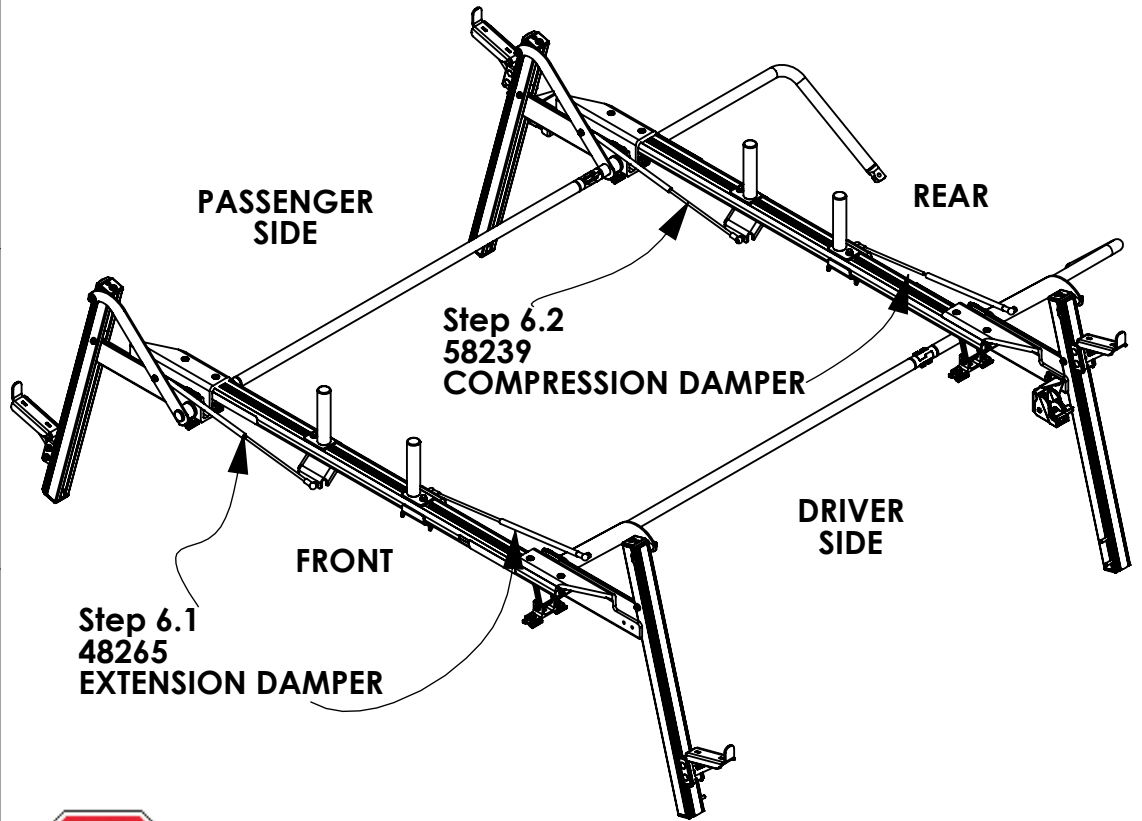

ORIENTATION OF DAMPER MATTERS!!!!

LARGE CYLINDER OF DAMPER ATTACHES TO ARM
 SMALL ROD END ATTACHES TO DAMPER BRACKET

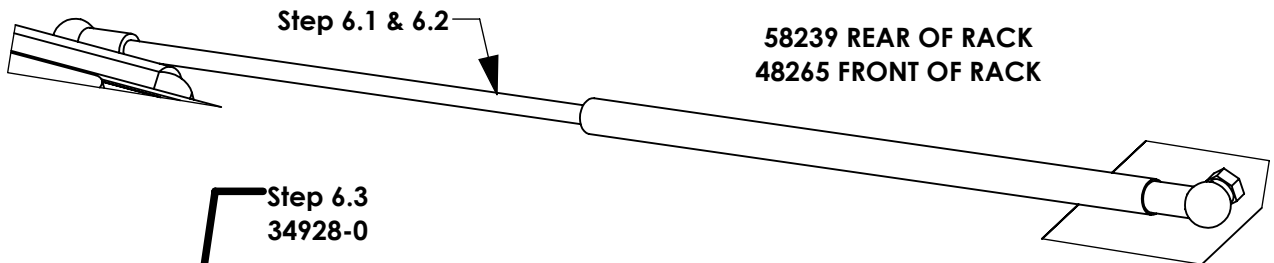

Step 6.3
 34928-0

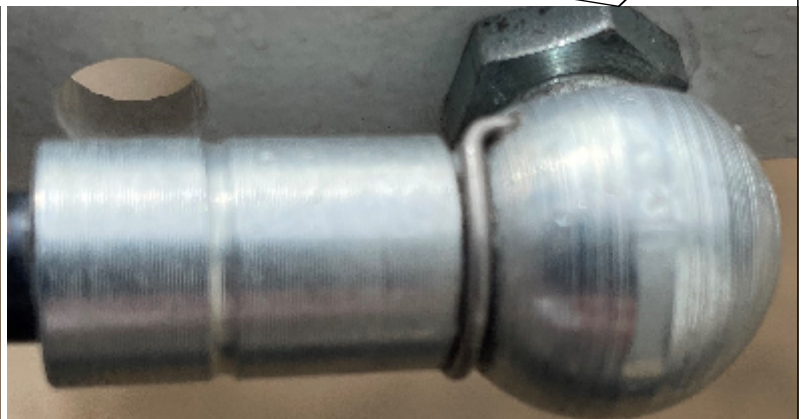
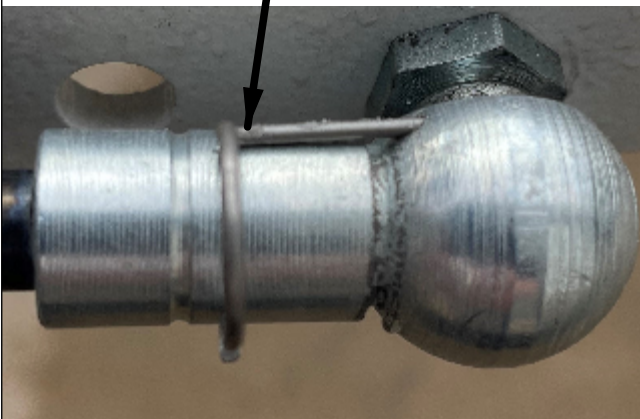

STEP 7 - WHILE RACK DEPLOYED INSTALL O.S. BAR

Step 7.1
FULLY TIGHTEN
FAS0861
(04 PLACES PER
SIDE)
1/2" SOCKET

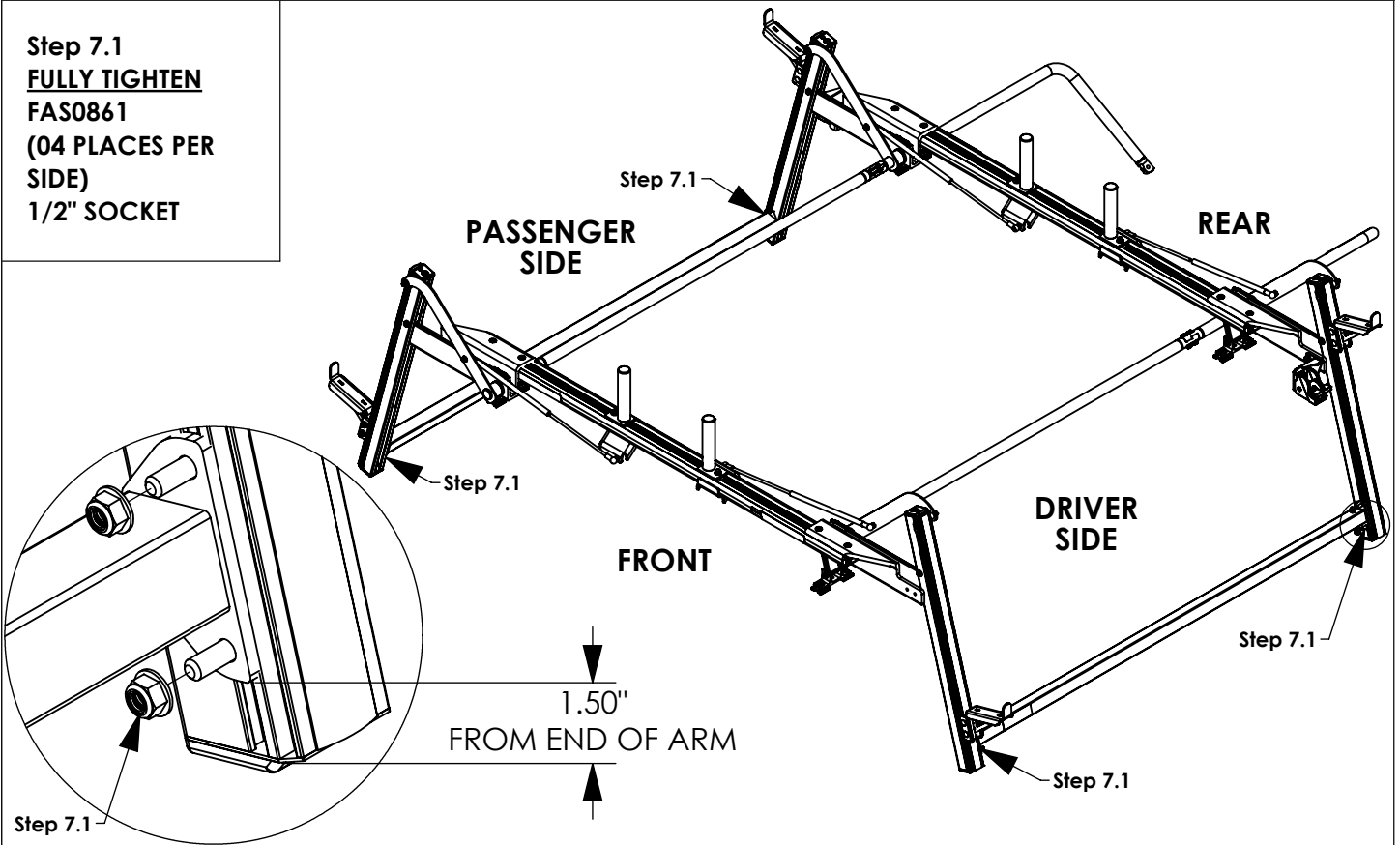

STEP 8 - INSTALL DROP DOWN HANDLE

Step 8.1
FULLY TIGHTEN
FAS0819 & FAS0399
(01 PLACES PER
SIDE)
7/32" ALLEN
9/16" SOCKET

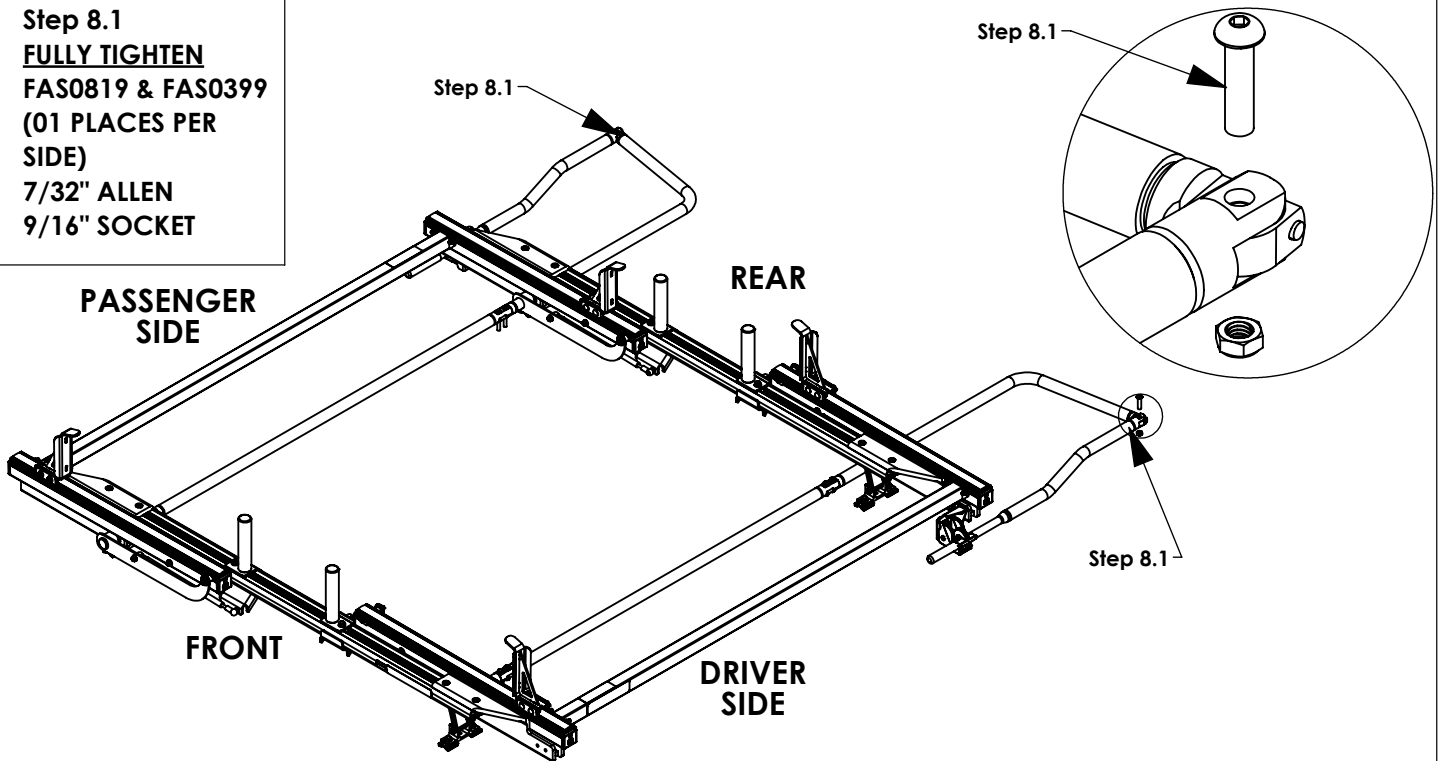

MAKE SURE ALL FASTENERS ARE TIGHTENED!!! INSTALLATION IS COMPLETE

STEP 9 - INSTALL CROSSBOW END CAPS

Step 9.1
FULLY TIGHTEN
(02) AS0473, 65961
(02 PLACES PER
SIDE)
3/8" SOCKET

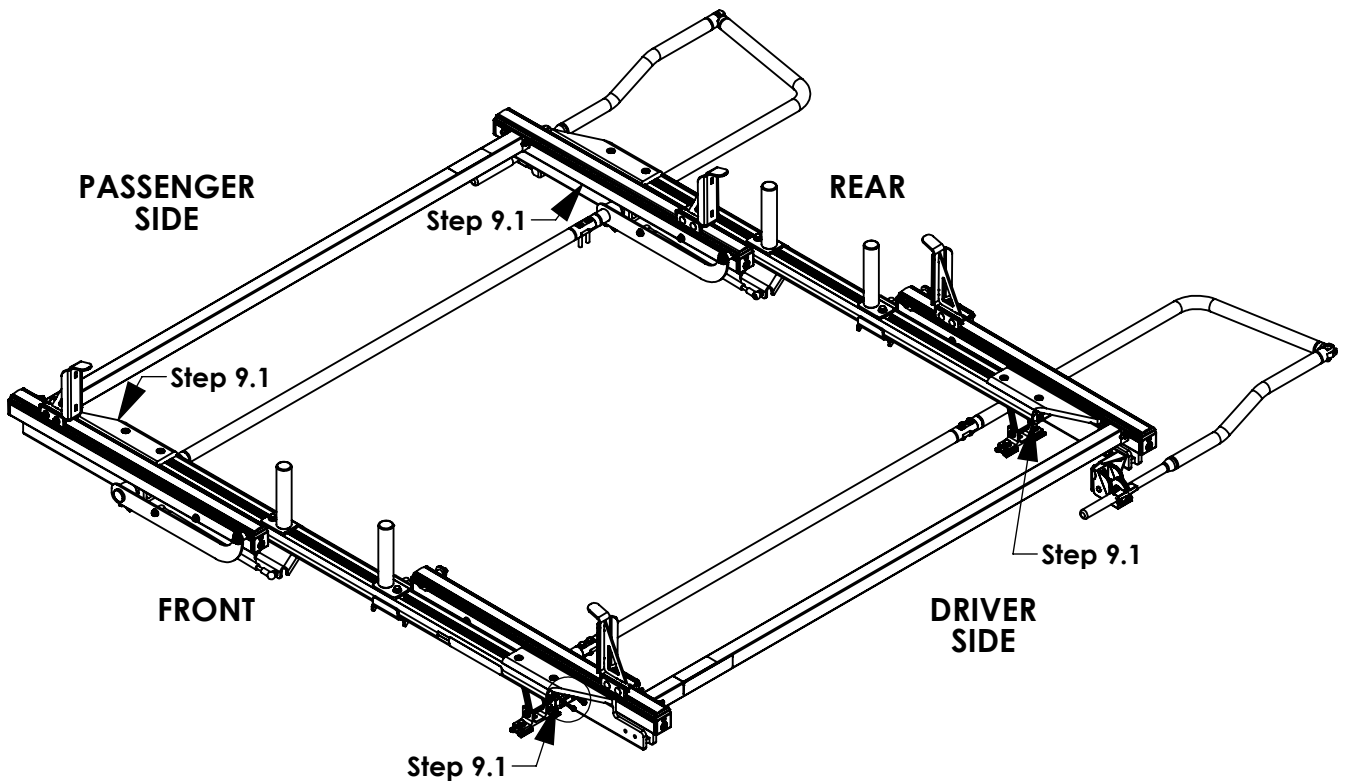
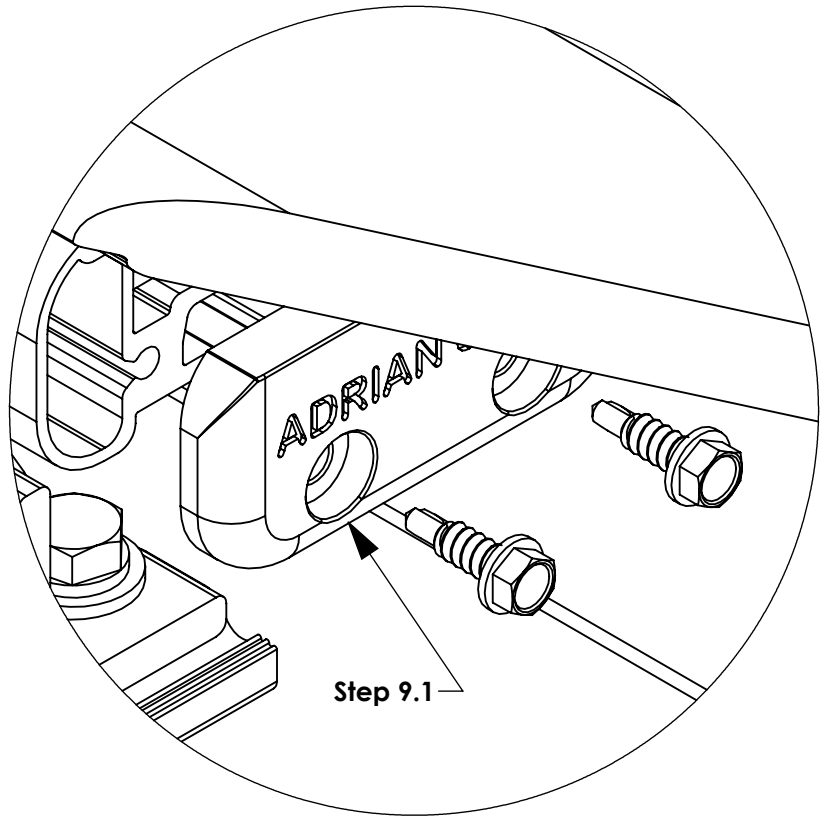

MAKE SURE ALL FASTENERS ARE TIGHTENED!!! INSTALLATION IS COMPLETE

<i>INSTR. NUMBER</i> : 68570	<i>PG:</i> 1	<i>REV:</i> A	<i>ITEM NO.</i>	<i>PART NUMBER</i>	<i>DESCRIPTION</i>	<i>QTY.</i>
			1	68569	ROOF RAIL W/FOAM,MMS,DS	1
<i>PART NUMBER</i> : RRKMMS			2	68568	ROOF RAIL W/FOAM,MMS,PS	1
<i>PART DESC.</i> : ROOF RAIL KIT, MM SWB						

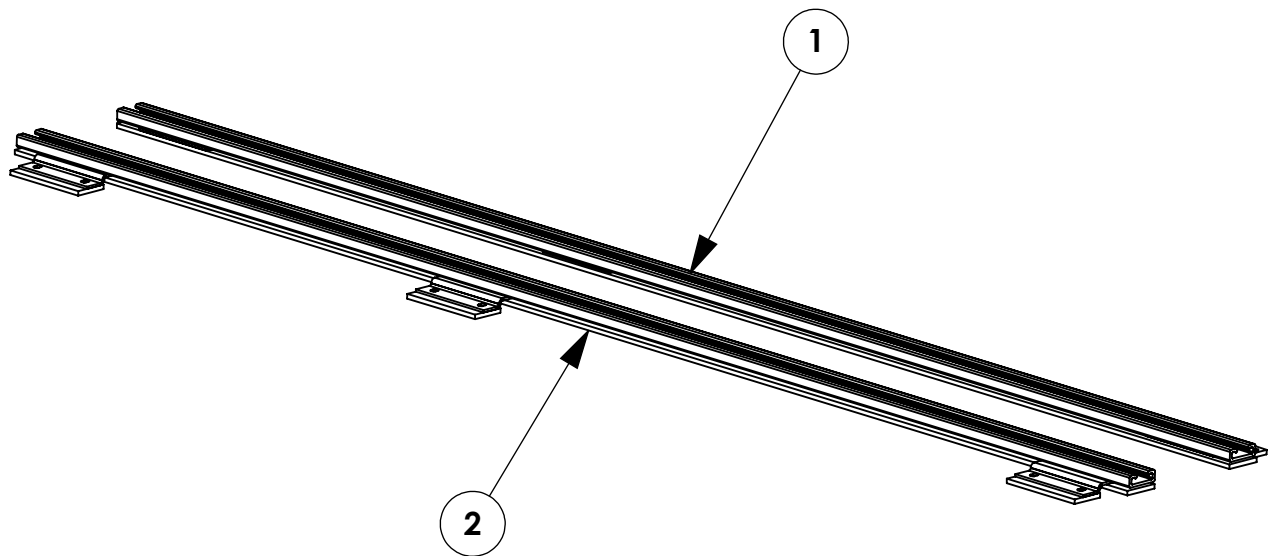

GET TO KNOW THE VEHICLE - AT THE BEGINNING OF ANY INSTALLATION, CHECK THE LOCATION OF THE FUEL TANK, FUEL LINES, BRAKE LINES, HIGH VOLTAGE BATTERIES AND WIRING HARNESSSES TO AVOID INJURY OR PROPERTY DAMAGE FROM TOOL CONTACT.

SEAL ALL EXTERIOR HOLES - ALL INSTALLATION HOLES SHOULD BE SEALED WITH BUTYL TAPE OR SILICON TO PREVENT WATER AND EXHAUST GASES FROM ENTERING THE VEHICLE.

CONTROL DRILL DEPTH - TO AVOID DAMAGE TO THE VEHICLE, USE A DRILL STOP OR CLEARED STEP BIT WHEN DRILLING INSTALLATION HOLES.

ALWAYS ADD PRIMER - WHEN ADDING INSTALLATION HOLES BE SURE TO USE A SELF-ETCHING PRIMER TO PREVENT CORROSION, FASTENER FAILURE AND INJURY.

MOUNTING POINTS MUST HAVE METAL-TO-METAL CONTACT - USE PROVIDED MOUNTING SPACERS TO ACCOMMODATE FOR VEHICLE FEATURES, CARPET OR SUBFLOORS.

PROVIDE CLEARANCE FOR SPACERS - IF THE INSTALLATION VEHICLE CONTAINS A CARPET OR SUBFLOOR, USE A 1-3/16" DIAMETER CARPET CUTTER (P/N: 31183-0) AT ALL MOUNTING LOCATIONS TO OPEN UP ROOM FOR SPACERS.

CHECK SPACER ORIENTATION - BE SURE THAT THE INDENT IN THE SPACER COVERS THE PLUSNUT HEAD; THIS ENSURES THE MOST METAL-TO-METAL CONTACT AND REDUCES VIBRATION.

PLUSNUT INSTALLATION - A PLUSNUT GUN IS RECOMMENDED FOR PLUSNUT INSTALLATION FOR ITS PRODUCTION SPEED. HOWEVER, A PLUSNUT SETTING TOOL CAN ALSO BE USED (P/N: 22200-0).

THRU-BOLT CLEARANCE - WHEN USING A THRU-BOLT AT ANY MOUNTING LOCATION, BE SURE THAT YOUR HOLE HAS 1/16" CLEARANCE.

FASTENERS USED

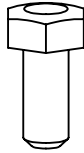

**FAS0268
M6-1 X 14.0 SS
HH SCREW
QTY: 12**



**FAS0672
1/4 SS
SPL WASHER
QTY: 12**



**FAS0234
1/4 SS
FLAT WASHER
QTY: 12**

STEP 1 - PREP ROOF HOLES

- a) REMOVE OEM PLASTIC PLUGS FROM REAR 3 ROOF MOUNTING PAIRS ON EACH SIDE OF ROOF.
- b) PROVIDED SCREWS ARE SHORT, BUT LONGER SCREWS MAY BOTTOM OUT IN THE ROOF AND PREVENT ADEQUATE CLAMPING OF THE RACK.

STEP 2 - INSTALL ROOF RAILS

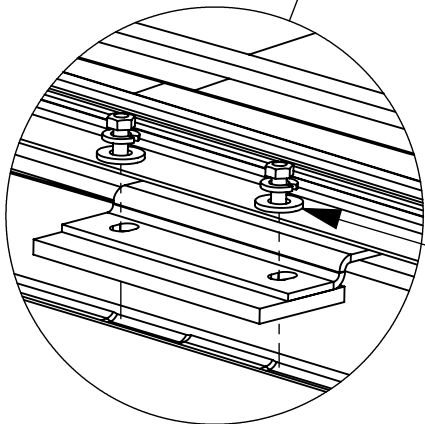
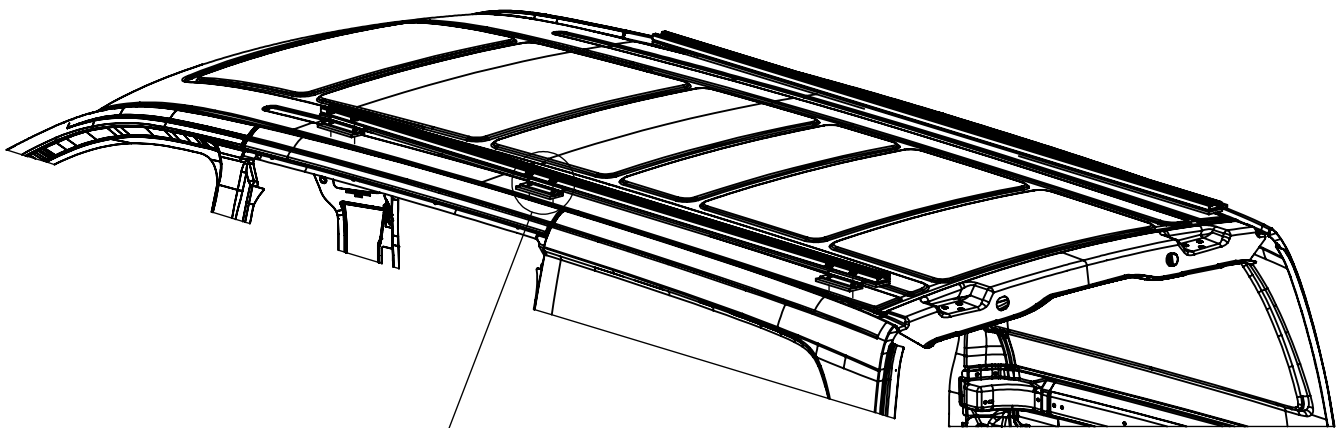

FAS0268, FAS0588,
FAS0234
(6 PLACES PER RAIL)
10mm SOCKET

ADD SILICONE TO THREADS

NOTE: END CAPS CANNOT BE ADDED UNTIL AFTER MOUNTING BRACKET KIT IS INSTALLED.



2-Crossbar Kit, 58", White, Minivan



PRODUCT WEIGHT
16.1 LBS

CROSSBOW LENGTH X
HEIGHT

59" x 2"

CAPACITY

**REFER TO OEM'S
RECOMMENDED LOAD
RATING**

COLOR

WHITE

CATALOG NUMBER

2BARCW

PRODUCT FEATURES

Aluminum base 2-crossbow kit for PROFILE™ HD Utility, grip lock, drop down, or combo ladder racks. Works with all compact van platforms for each respective wheelbase and Ford Transit Ship Thru. Works with and without OEM specific rail kit and generic mounting bracket kits.

Optional uprights and conduit kits available.

Please refer to OEM specific mounting kit or rail kit for additional information on compatible accessories.

INSTALLATION GUIDE FOR PROFILE™ SERIES LADDER RACKS

INSTRUCTION #:
68895

REV:
B

THIS INSTRUCTION PROVIDES A GENERAL GUIDE OF INSTALLATION SEQUENCE FOR ALL PROFILE™ SERIES LADDER RACKS. PLEASE ENSURE ALL ACCESSORIES ARE INSTALLED PER TYPE OF RACK BEFORE PROCEEDING TO NEXT PAGE.

REFERENCE THIS INSTRUCTION THROUGHOUT THE ENTIRETY OF YOUR INSTALL TO PREVENT ACCESSORIES BEING INSTALLED INCORRECTLY/OUT OF SEQUENCE!

STEPS 21 - 81 ON PAGE 3 IS THE RECOMMENDED ASSEMBLY SEQUENCE FOR A FULL TABLE ASSEMBLY BEFORE INSTALLING ON THE ROOF OF THE VEHICLE.

STEPS 2R - 8R ON PAGE 4 IS AN ALTERNATE ASSEMBLY SEQUENCE TO INSTALL THE RACK ON THE VEHICLE ROOF AS IT IS BUILT.

PLEASE SELECT THE ASSEMBLY SEQUENCE THAT BEST WORKS FOR YOU!

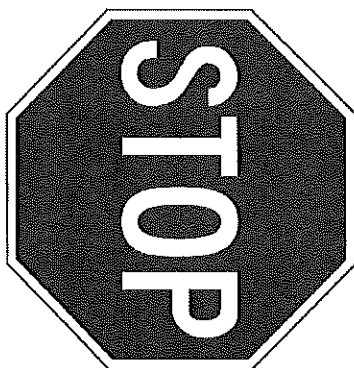

ASSEMBLY STEPS:

STEP 1A. SUB-ASSEMBLE EACH CROSSBOW WITH DESIRED ACCESSORIES FOR SECTIONS A.1 & A.2.

INSTRUCTIONS FOR EACH KIT CAN BE FOUND IN THEIR RESPECTIVE CARTON!

TOP OF CROSSBOW *IMAGE NOT TO SCALE!

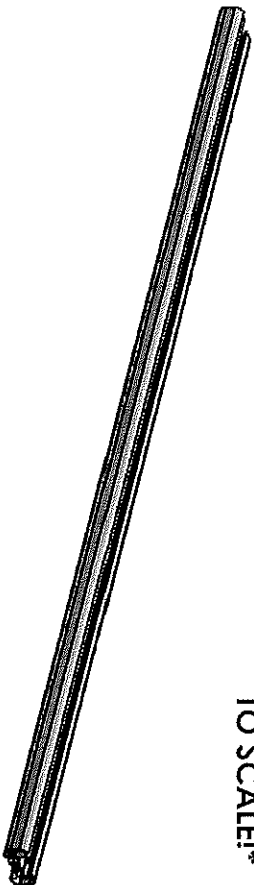

BOTTOM OF CROSSBOW

TABLE 1

TOP OF CROSSBOW		COMPONENTS TO INSTALL
HD UTILITY		- CONDUIT KIT OR BEACON
Grip-Lock		- CONDUIT KIT OR BEACON
ProLift		- CONDUIT KIT OR BEACON
BOTTOM OF CROSSBOW		
COMPONENTS TO INSTALL		
HD UTILITY		- LADDER STOP, STROBE BRACKET, AND/OR REAR ROLLER
Grip-Lock		- Grip-Lock SUB-ASSEMBLY
ProLift		- DAMPER BRACKET

STEP 1B. SUB-ASSEMBLE EACH CROSSBOW WITH DESIRED ACCESSORIES FOR SECTIONS B.1 & B.2. INSTRUCTIONS FOR EACH KIT CAN BE FOUND IN THEIR RESPECTIVE CARTON!

TOP OF CROSSBOW

IMAGE NOT TO SCALE!

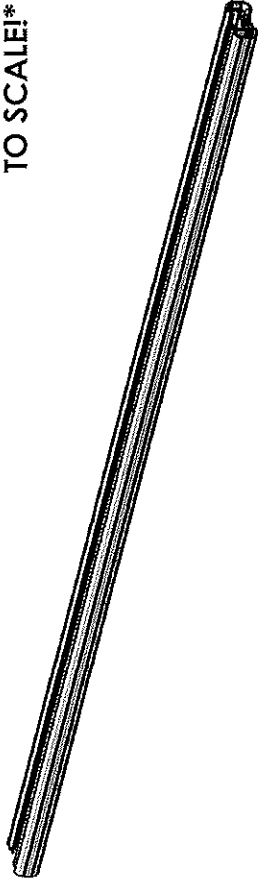

BOTTOM OF CROSSBOW

TABLE 2

TOP OF CROSSBOW	
COMPONENTS TO INSTALL	
HD UTILITY	- WEAR STRIP (MODIFY IF NECESSARY, TABLE 3)
Grip-Lock	- WEAR STRIP (MODIFY IF NECESSARY, TABLE 3)
ProLift	- INNER STOP POST
BOTTOM OF CROSSBOW	
COMPONENTS TO INSTALL	
HD UTILITY	- MOUNTING BRACKETS
Grip-Lock	- MOUNTING BRACKETS
ProLift	- MOUNTING BRACKETS

ALTER WEAR STRIP AND INSTALL ON CROSSBOW (IF APPLICABLE)! REFERENCE TABLE 3 BELOW FOR WEAR STRIP ALTERATION INSTRUCTIONS!

TABLE 3

ADDED ACCESSORIES	ALTERATION FOR WEAR STRIP
4" UPRIGHT***	REMOVE 2" FROM END OF WEAR STRIP
4" PVC CONDUIT KIT	REMOVE 7.25" FROM CENTER OF WEAR STRIP
6" PVC CONDUIT KIT	REMOVE 9.50" FROM CENTER OF WEAR STRIP
ALUMINUM BOX CONDUIT KIT	REMOVE 13.25" FROM CENTER OF WEAR STRIP
BEACON	REMOVE 4" FROM CENTER OF WEAR STRIP
ProLift (SINGLE SIDE)	CUT WEAR STRIP IN HALF, DO NOT INSTALL ON ProLift SIDE
ProLift (DUAL SIDE)	DO NOT INSTALL WEAR STRIP

SLIDE WEAR STRIP INTO RAIL AND CENTER (1 PER CROSSBOW)

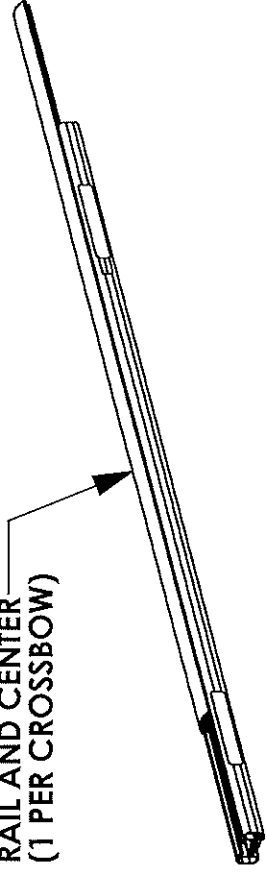

STEP 1C SUB-ASSEMBLE EACH CROSSBOW WITH DESIRED ACCESSORIES FOR SECTIONS C.1 & C.2

TOP OF CROSSBOW
IMAGE NOT TO SCALE!

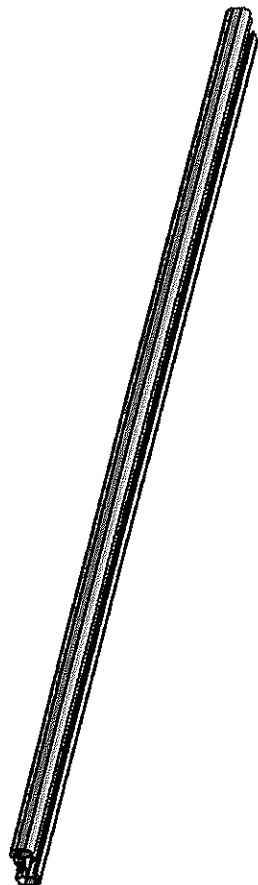

BOTTOM OF CROSSBOW

TABLE 4

TOP OF CROSSBOW		COMPONENTS TO INSTALL
	HD UTILITY	- 4" UPRIGHT
C.1	Grip-Lock	- N/A
	Prolift	- SLIDES FOR BASE EXTRUSION
BOTTOM OF CROSSBOW		
COMPONENTS TO INSTALL		
	HD UTILITY	- UPRIGHTS (6", 9", RATCHET)
C.2	Grip-Lock	- STROBES
	Prolift	- STROBES

ASSEMBLY STEPS (FULL BENCH ASSEMBLY):

- 2T. ADD DRIVELINES (IF INSTALLING Prolift)
- 3T. ADD HANDLES (IF INSTALLING Grip-Lock OR Prolift) AND DAMPERS (IF INSTALLING Prolift)
- 4T. ADD OUTER SUPPORT BARS (IF INSTALLING Grip-Lock OR Prolift)
- 5T. ADD STEP LADDER KIT (Grip-Lock OR Prolift ONLY)

6T. ASSEMBLE ENDS CAPS TO CROSSBOW

USED FOR HD UTILITY & Grip-Lock RACKS

LOCATED IN CROSSBOW KIT

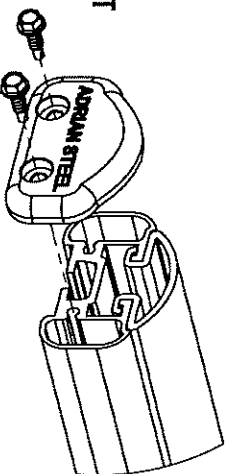

FULLY TIGHTEN
(2) FAS0473, 63851
(2 PLACES PER END CAP)
5/16" SOCKET

USED FOR Prolift RACKS
LOCATED IN Prolift Kit

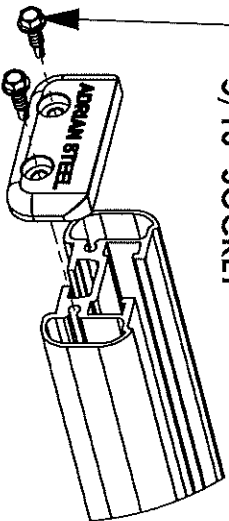

7T. INSTALL ROOF RAIL KIT ON VEHICLE ROOF OR BOTTOM MOUNTING BRACKETS

(ROOF RAIL KIT REQUIRED FOR Grip-Lock & Prolift OPTIONAL FOR HD UTILITY, NOT NEEDED FOR GM LADDER RACKS)

8T. MOUNT CROSSBOW SUB-ASSEMBLIES FROM STEP 1 TO VEHICLE/MOUNTING BRACKET, OR ROOF RAIL (LOOSE INSTALL)

ALTERNATE ASSEMBLY METHOD!
(ASSEMBLE ON VEHICLE ROOF):

- 2R. INSTALL ROOF RAIL KIT ON VEHICLE ROOF OR BOTTOM MOUNTING BRACKETS
(ROOF RAIL KIT REQUIRED FOR Grip-Lock & ProLift, OPTIONAL FOR HD UTILITY, NOT NEEDED FOR GM LADDER RACKS)
- 3R. MOUNT CROSSBOW SUB-ASSEMBLIES FROM STEP 1 TO VEHICLE/MOUNTING BRACKET, OR ROOF RAIL (LOOSE INSTALL)
- 4R. ADD DRIVELINES (IF INSTALLING ProLift)
- 5R. ADD HANDLES (IF INSTALLING Grip-Lock OR ProLift) AND DAMPERS (IF INSTALLING ProLift)
- 6R. ADD OUTER SUPPORT BARS (IF INSTALLING Grip-Lock OR ProLift)
- 7R. ADD STEP LADDER KIT (Grip-Lock OR ProLift ONLY!)

8R. ASSEMBLE END CAPS TO CROSSBOW

USED FOR HD UTILITY & Grip-Lock RACKS

LOCATED IN CROSSBOW KIT

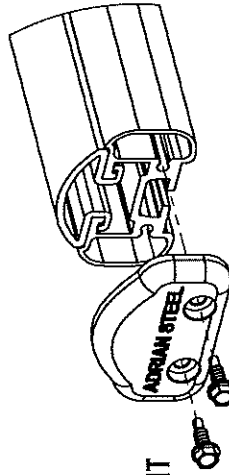

FULLY TIGHTEN
(2) FAS0473, 63851
(2 PLACES PER END CAP)
5/16" SOCKET

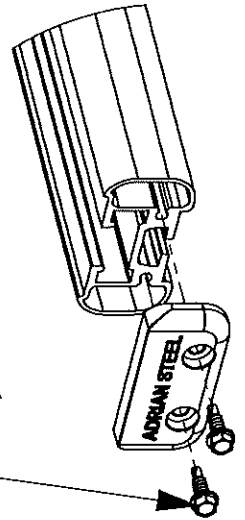

USED FOR ProLift RACKS
LOCATED IN ProLift Kit