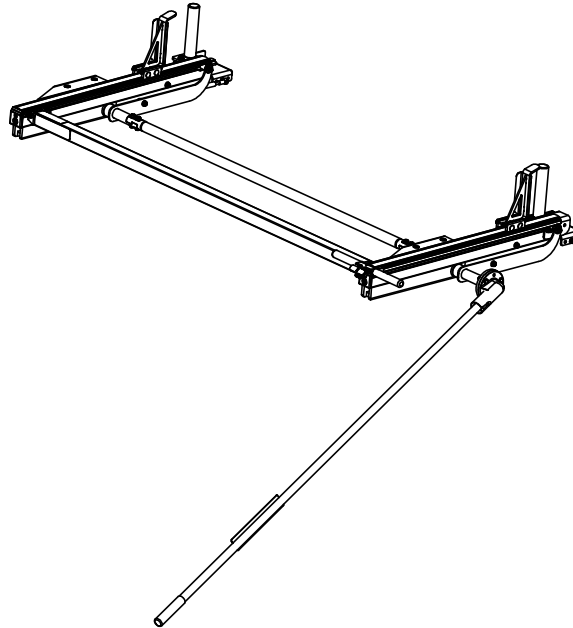

**ADRIAN STEEL**

Cargo Management Solutions for Commercial Vehicles

PROLIFT MAX DROP MID TOPPER 5' PASSENGERS SIDE LADDER RACK

PRODUCT WEIGHT**65.5 LBS****WIDTH X DEPTH X HEIGHT****82.00" X 32.00" X4.00"****CAPACITY****SINGLE LADDER****COLOR****WHITE/BLACK****CATALOG NUMBER****PLMDPSMT5W, PLMDPSMT5B**

PRODUCT FEATURES

ProLift™ Max Drop Topper racks can be used on ADRIAN STEEL BIFF, LEER, UNICOVER and ARE truck toppers with bed lengths from 6'2" - 6'10" with appropriate rail kit, crossbow kit and mounting bracket kit. Use rail kits, crossbow kits, and mounting bracket kits listed in the table below to create new rack combinations.

NOTE: Unicover Toppers will use roof rail kits ending in UC (Ex. 4'6" Unicover topper would use RRKTOP55UC)

Ignore the roof rail kit when ordering racks for ASC BIFF toppers as they ship with pre-installed rails.

Commercial Part Numbers

Vehicle Platform	Bed Length	Bed Length (in)	Roof Rail Kit	Crossbow kit	Mounting Bracket Kit	Pro-Lift (Passenger Side)	Pro-Lift (Drivers Side)
All	6'2" - 6'10"	74" - 82"	RRKTOP74/UC	2BARTOPW	URMBK4W	PLSDPSLT5	PLSDDSLT5

NOTE:CROSSBAR KIT IS DIFFERENT FOR COMBO WITH GRIPLOCK. IN THIS CASE,USE 2BAR53W/B

SEE PAGE 2 FOR APPLICATION NOTES, ACCESSORIES AND OTHER PRODUCTS THAT WORK WITH THIS UNIT.



PROLIFT MAX DROP MID TOPPER 5' PASSENGERS SIDE LADDER RACK

CATALOG NUMBER

PLMDPSMT5W, PLMDPSMT5B

PRODUCT APPLICATION

TOPPER PROLIFT LADDER RACKS ARE FOR USE ON PICKUP TRUCK BED TOPPERS, AVAILABLE IN 4 FT, 5 FT, AND 6 FT LENGTHS FOR ALL DIFFERENT SIZE TRUCK BEDS.

Reduce back and shoulder injuries while loading/unloading ladders by eliminating the need to climb on bumpers and tires to reach the cargo on the roof of your vehicle.

The ProLift™ uses unique, patent-pending, mechanical advantages, and high-performing spring assist struts to raise and lower ladders with an almost effortless pull.

ACCESSORIES THAT WILL WORK WITH THIS PRODUCT

CATALOG NUMBER	DESCRIPTION (smart)
RRKTOP74	ROOF RAIL KIT,TOPPER,74"
RRKTOP74UC	ROOF RAIL KIT,TOPPER,74" UNICOVER
2BARTOPW / B	2BAR UTILITY RACK, TOP
2BAR53W / B	2BAR, CROSSBOW,53"
URMBK4W / B	UTILITY,MNT BKT KT,RAIL
GL-CVDSW / B	GRIP-LOCK,COMP VAN DS
PLMDDSMT5W/B	PROLIFT,MAX,PS,MID T,5

INSTR. NUMBER : 69483	PG: 1	REV: A
PART NUMBER • Max Drop ProLift - Low & Mid-Roof		
PART • ProLift Low & Mid-Roof DESC. • Adjustment Instructions		

**Step 2: With 1/2" Socket loosen nut, slide post so that it is snug against ladder
Tighten nut**

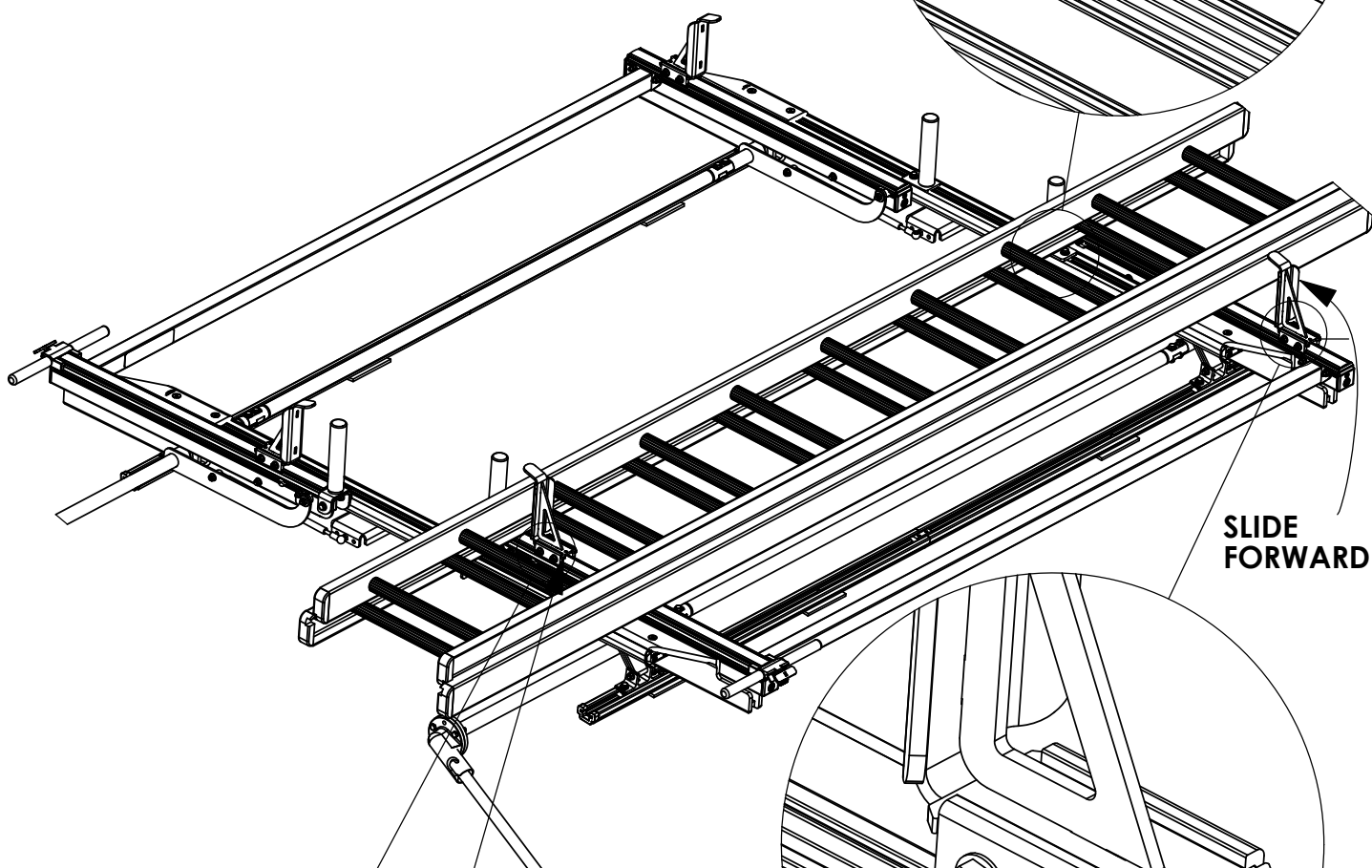
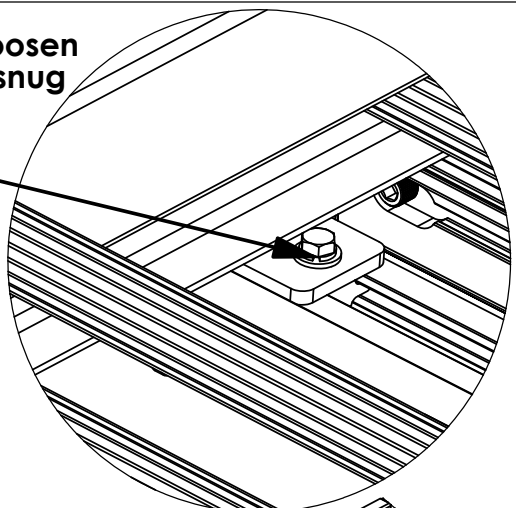

SLIDE FORWARD

SLIDE FORWARD

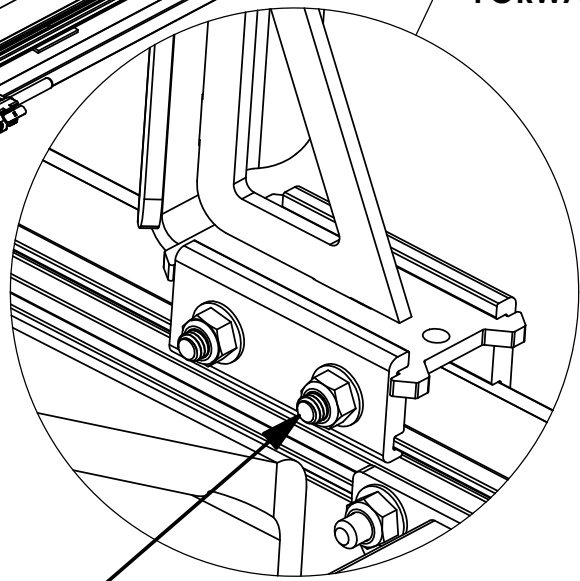

**Step 3: With 1/2" Socket loosen nuts (x2) slide clamp so that it is snug against outside of ladder
Tighten nuts (X2)**

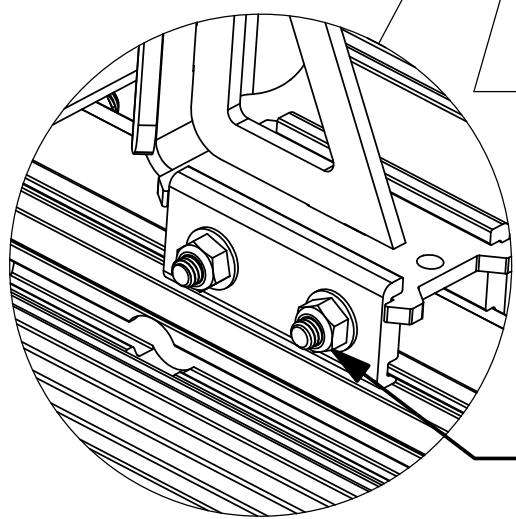

**Step 1: With 1/2" Socket loosen nuts (x2) slide clamp so that it is snug against ladder
Tighten nuts (X2)**

Once all brackets are adjusted operate rack to make sure clamps are not too tight

INSTR. NUMBER	PG:	REV:	ITEM NO.	PART NUMBER	DESCRIPTION	PLMDPSMT	PLMDDSMT
: 70120	1	B	1/14	70108-W	PROLIFT,MMT,DR ASM,PS,R,W	1	-
			2/15	68031-W	DROP DOWN FRONT ARM ASSM PS, WHITE	1	-
PART NUMBER : PLMDPSMT & PLMDDSMT			3/16	66572-B	DROP DOWN, CS CENTER DRIVELINE, BLK	1	-
PART DESC. • PROLIFT,MAX,PS,MT & PROLIFT,MAX,DS,MT			4	48265	DAMPER ASSEMBLY	1	1
			5	58239	COMPRESSION DAMPER	1	1
			6	51989	HANDLE ASM, NO PAINT	1	1
			7	68037-B	CLAMP PAD, 6.5", BLACK	2	2
			8	65961	DROP DOWN END CAP	2	2
			9	66959-W	DROP DOWN OUTER BAR, WELDMENT, WHITE	1	1
			10	65963-W	STOP CLAMP, WHITE	4	4
			11	68186-W	PROLIFT INNER POST, WHITE	1	1
			12	68196-W	PROLIFT MAX DROP STOP, WHITE	1	1
			13	68628-W	PROLIFT HR DAMPER MOUNT, WHITE	2	2
			14	70109-W	PROLIFT,MMT,DR ASM,DS,R,W	-	1
			15	68013-W	DROP DOWN FRONT ARM ASSM DS, WHITE	-	1
			16	66959-B	DROP DOWN, SS CENTER DRIVELINE, BLK	-	1

- PART NUMBERS WITH "-W" SUFFIX ARE PAINTED WHITE
- FOR BLACK MOUNTING KITS, REPLACE "-W" PARTS WITH "-B" PARTS

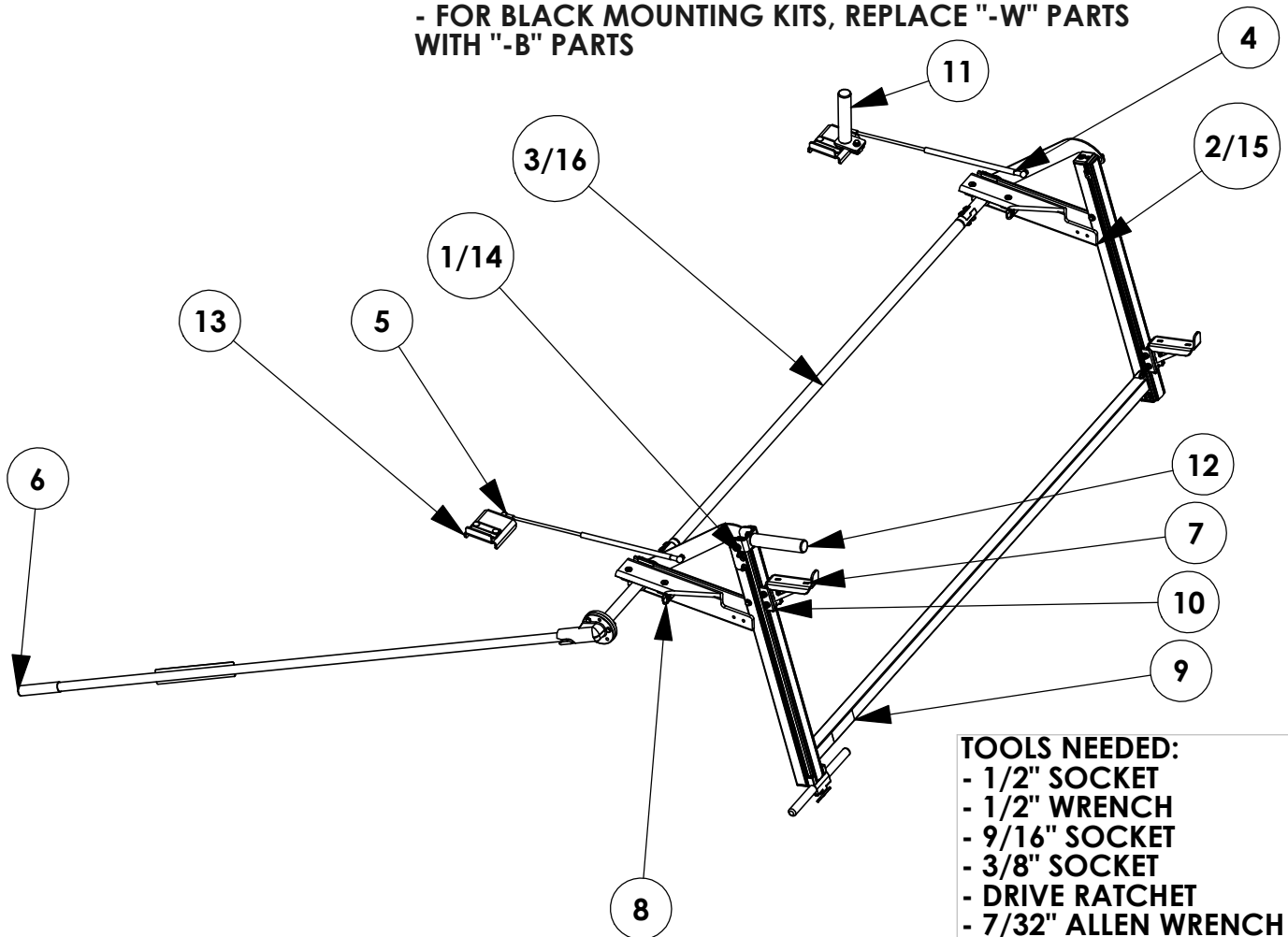

- TOOLS NEEDED:**
- 1/2" SOCKET
 - 1/2" WRENCH
 - 9/16" SOCKET
 - 3/8" SOCKET
 - DRIVE RATCHET
 - 7/32" ALLEN WRENCH
 - 3/16" ALLEN WRENCH
 - 13mm WRENCH
 - TAPE MEASURE
 - RUBBER Mallet
 - IMPACT DRIVER

****IF BUILDING A DUAL SIDED RACK BUILD BOTH SIDES IN PARALLEL FOR EACH STEP. IF BUILDING SINGLE SIDED REFERENCE ONLY THAT SIDE WHEN BUILDING.****

GET TO KNOW THE VEHICLE - AT THE BEGINNING OF ANY INSTALLATION, CHECK THE LOCATION OF THE FUEL TANK, FUEL LINES, BRAKE LINES, HIGH VOLTAGE BATTERIES AND WIRING HARNESSSES TO AVOID INJURY OR PROPERTY DAMAGE FROM TOOL CONTACT.

SEAL ALL EXTERIOR HOLES - ALL INSTALLATION HOLES SHOULD BE SEALED WITH BUTYL TAPE OR SILICON TO PREVENT WATER AND EXHAUST GASES FROM ENTERING THE VEHICLE.

CONTROL DRILL DEPTH - TO AVOID DAMAGE TO THE VEHICLE, USE A DRILL STOP OR CLEARED STEP BIT WHEN DRILLING INSTALLATION HOLES.

ALWAYS ADD PRIMER - WHEN ADDING INSTALLATION HOLES BE SURE TO USE A SELF-ETCHING PRIMER TO PREVENT CORROSION, FASTENER FAILURE AND INJURY.

MOUNTING POINTS MUST HAVE METAL-TO-METAL CONTACT - USE PROVIDED MOUNTING SPACERS TO ACCOMMODATE FOR VEHICLE FEATURES, CARPET OR SUBFLOORS.

PROVIDE CLEARANCE FOR SPACERS - IF THE INSTALLATION VEHICLE CONTAINS A CARPET OR SUBFLOOR, USE A 1-3/16" DIAMETER CARPET CUTTER (P/N: 31183-0) AT ALL MOUNTING LOCATIONS TO OPEN UP ROOM FOR SPACERS.

CHECK SPACER ORIENTATION - BE SURE THAT THE INDENT IN THE SPACER COVERS THE PLUSNUT HEAD; THIS ENSURES THE MOST METAL-TO-METAL CONTACT AND REDUCES VIBRATION.

PLUSNUT INSTALLATION - A PLUSNUT GUN IS RECOMMENDED FOR PLUSNUT INSTALLATION FOR ITS PRODUCTION SPEED. HOWEVER, A PLUSNUT SETTING TOOL CAN ALSO BE USED (P/N: 22200-0).

THRU-BOLT CLEARANCE - WHEN USING A THRU-BOLT AT ANY MOUNTING LOCATION, BE SURE THAT YOUR HOLE HAS 1/16" CLEARANCE.

BEST PRACTICE: ORGANIZE ALL FASTENERS & VERIFY THAT ALL ARE ACCOUNTED FOR

PAGE:

3

FASTENERS AND HARDWARE USED

BAG REFERENCE: BAG68181 & BAG68182

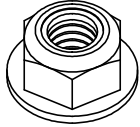

FAS0861
NUT,HEX NLK FLG 5/16-18
QTY: 20



FAS0110
NUT,HEX NLK 3/8-16
QTY: 01



FAS0399
NUT,HEX NLK LT 3/8-16
QTY: 01

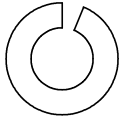

FAS0588
WASHER,LCK SPLIT 5/16
QTY: 03

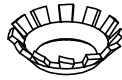

FAS0857
WASHER,LCK EXT CS 5/16
QTY: 04

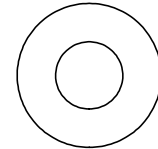

FAS0552
WASHER,FLAT USS 5/16
QTY: 09

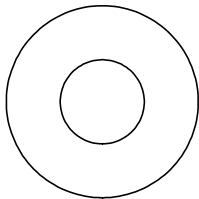

FAS0720
WASHER,FLAT USS 3/8
QTY: 01



FAS0283
SCREW,HH 5/16-18X.875
QTY: 03

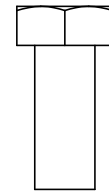

FAS0799
SCREW,HH 5/16-18X.75
QTY: 02

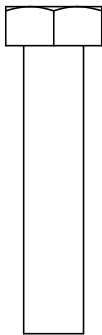

FAS0242
SCREW,HH 5/16-18X1.5
QTY: 04

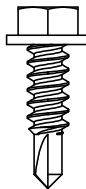

FAS0473
SCREW,HH TEK #12X.75
QTY: 04



FAS0856
SCREW,FHH 5/16-18X1.13
QTY: 04

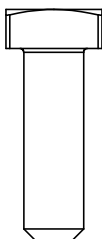

FAS0035
BOLT,SQ HD 5/16-18X1.0
QTY: 02

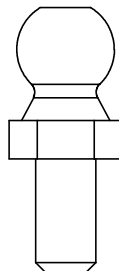

34927-0
BALL STUD 13MM X 5/16-18
QTY: 02

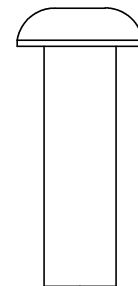

FAS0701
SCREW,BHCS 3/8-16X1.25
QTY: 01

INTENTIONALLY LEFT BLANK

FASTENERS AND HARDWARE USED

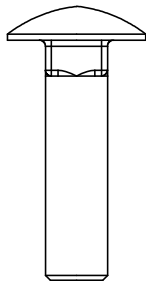

FAS0812
BOLT,CRG 5/16-18X1.25
QTY: 04

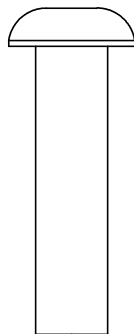

FAS0819
SCREW,BHCS 3/8-16X1.5
QTY: 01

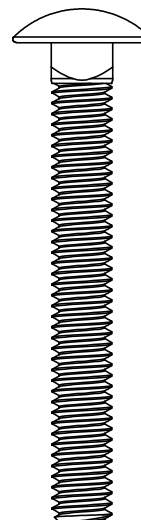

FAS0838
BOLT,CRG 5/16-18X2.5
QTY: 04



64831
REAR ROLLER, SPACER
QTY: 02

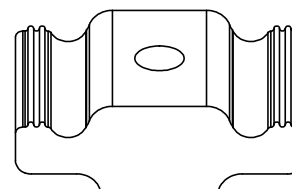

63490
RAIL SLIDE, 1"
QTY: 05

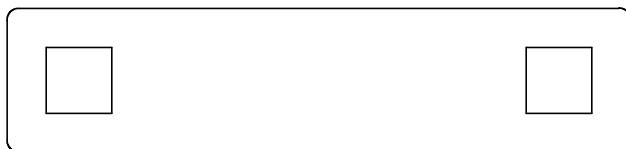

64830
REAR ROLLER, BOLT PLATE
QTY: 02



34928-0
CLIP, SPRING, RETAINER, 13MM
QTY: 04

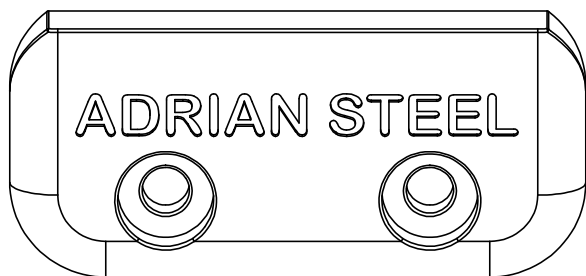

65961
DROP DOWN END CAP
QTY: 02

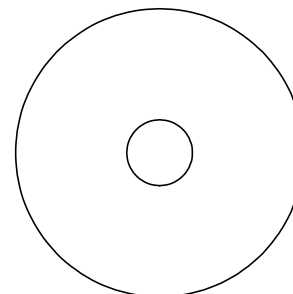

DISCARD FAS0603
SCREW,HH 5/16-18X.875
QTY: 01

INTENTIONALLY LEFT BLANK

STEP 1 - MOUNT DAMPER BRACKETS

A.2

Step 1.1
FULLY TIGHTEN
 34927-0 & FAS0861
 (02 PLACES PER
 SIDE)
 13mm WRENCH
 1/2" SOCKET

STEP 1.2
FULLY TIGHTEN
 (02) FAS0812,
 64830, 64831, &
 (02) FAS0861
 (02 PLACES PER
 SIDE)
 1/2" SOCKET

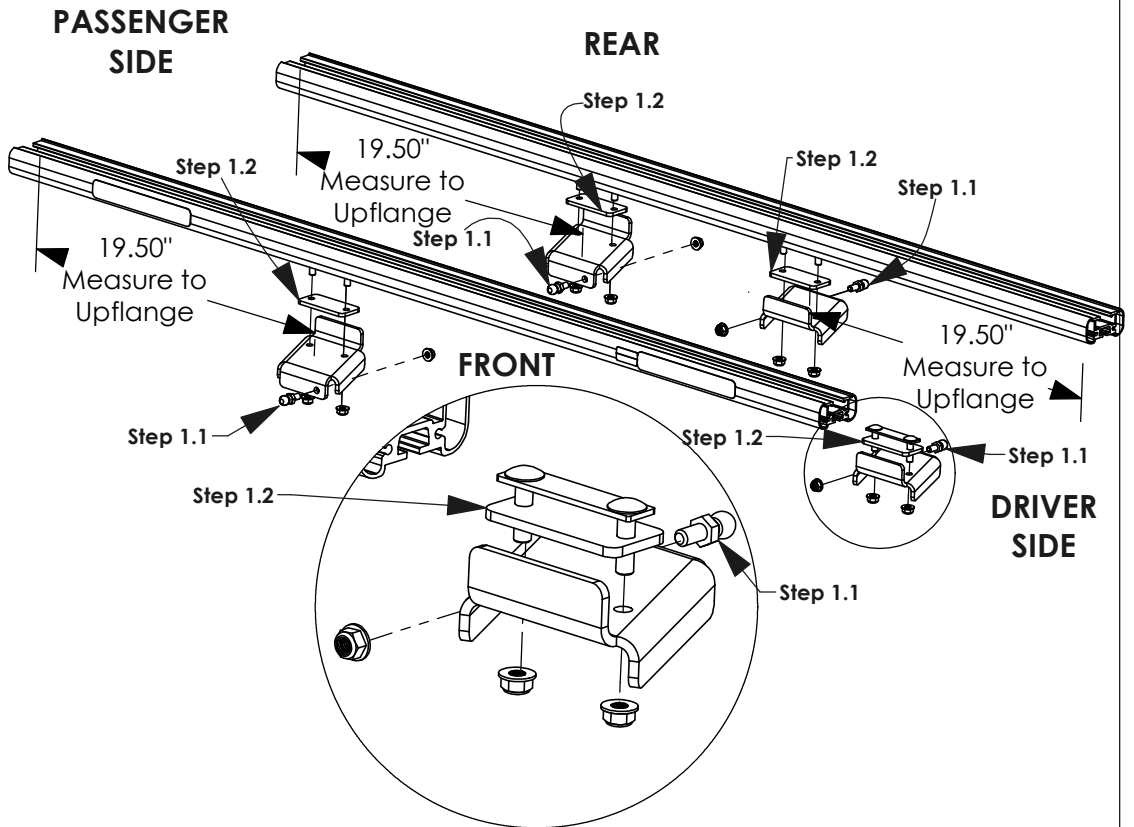

STEP 2 - MOUNT INNER STOPS TO FRONT CROSSBOW

B.1

STEP 2.1
FULLY TIGHTEN
 FAS0283, FAS0552,
 & FAS0588, 63490
 (01 PLACE PER
 SIDE)
 1/2" SOCKET

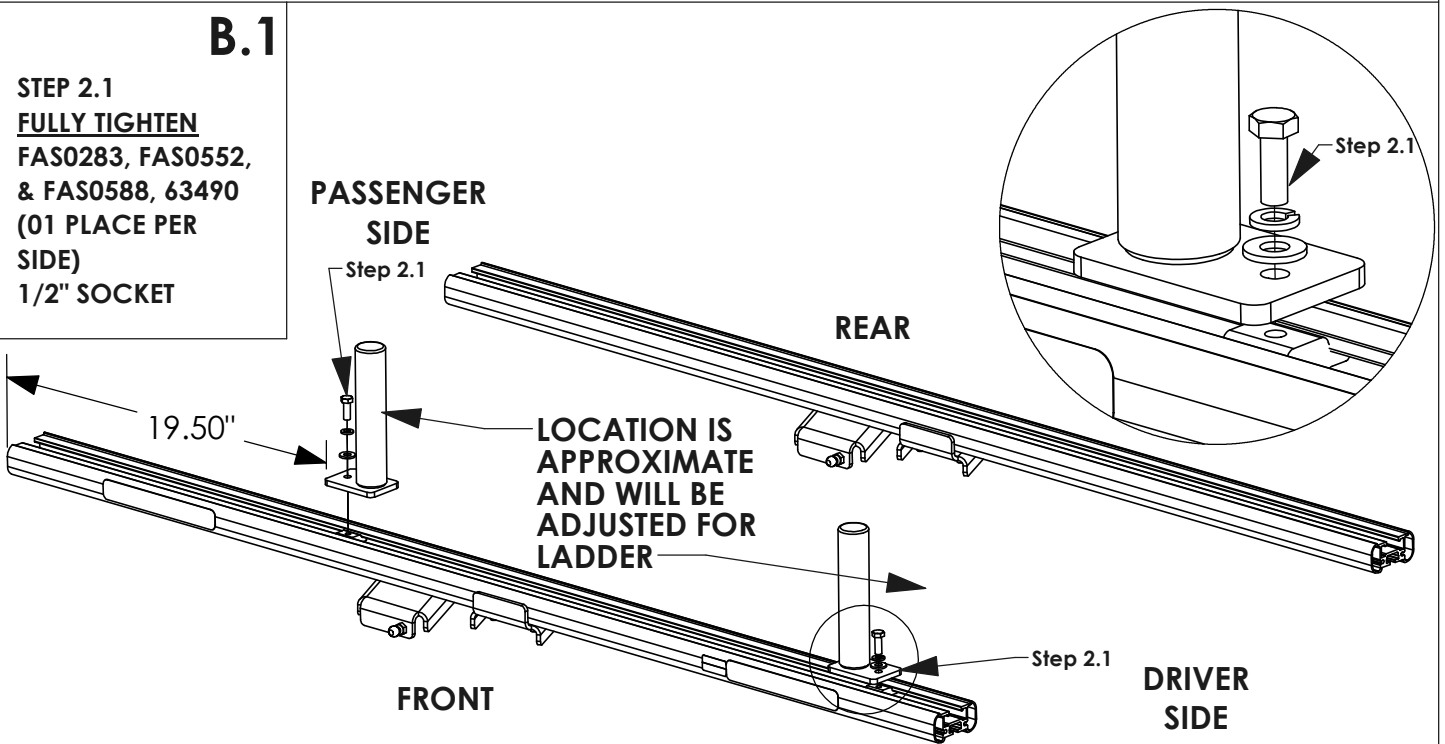

STEP 3 - INSTALL CLAMPS AND HARDWARE ON DROP DOWN CARTRIDGES

REAR SUB-ASSEMBLY

PASSENGER SIDE

68012-W/B

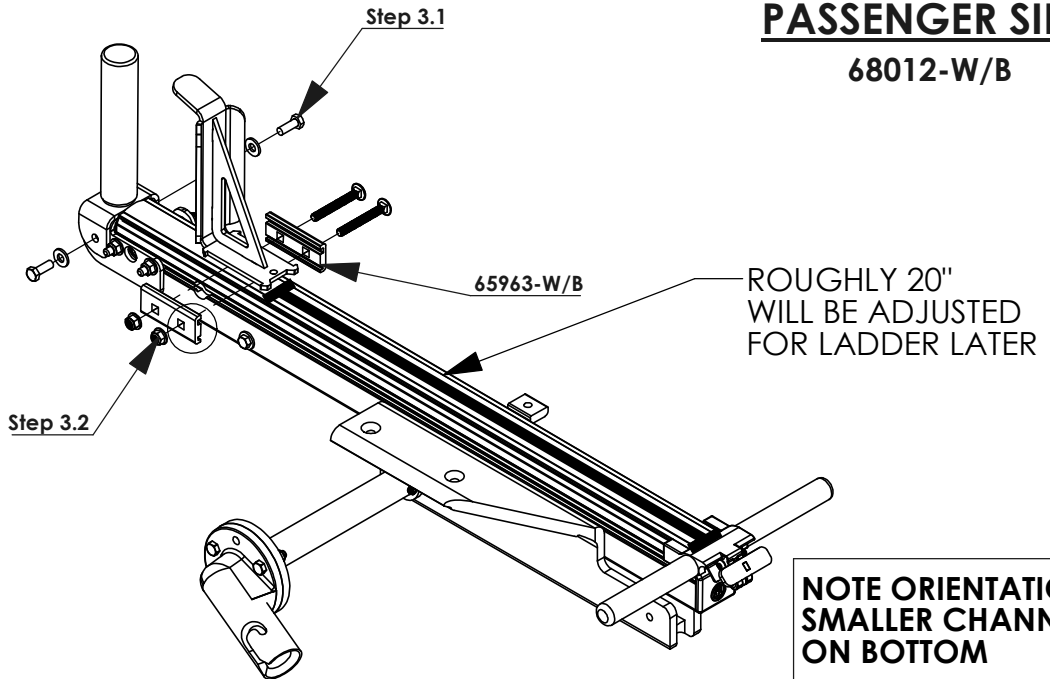

STEP 3.1
FULLY TIGHTEN
 FAS0283, FAS0552,
 & FAS0861
 (02 PLACES)
 1/2" WRENCH
 1/2" SOCKET

**NOTE ORIENTATION:
 SMALLER CHANNEL
 ON BOTTOM**

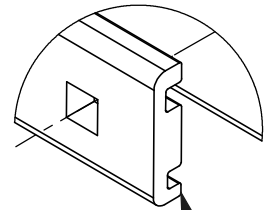

65963-W/B

DRIVERS SIDE

68012-W/B

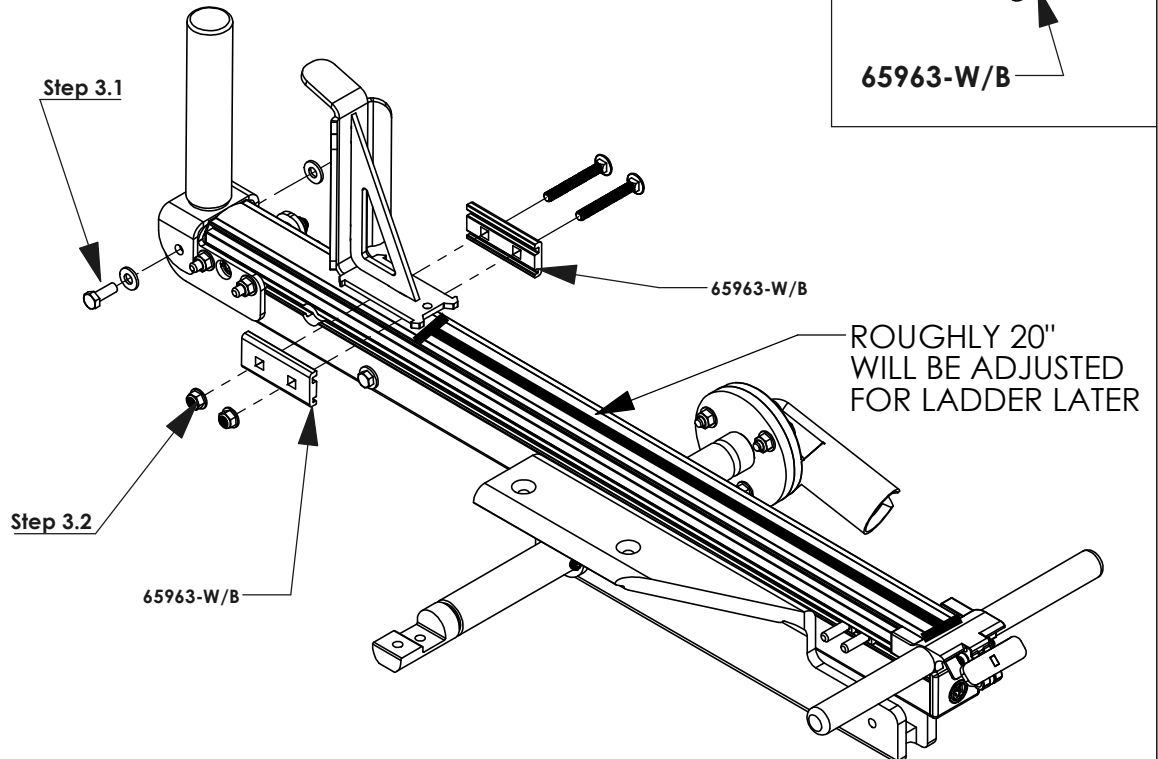

STEP 3.2
FULLY TIGHTEN
 FAS0838 &
 FAS0861
 (02 PLACES)
 1/2" SOCKET

FRONT SUB-ASSEMBLY

PASSENGER SIDE

68031-W/B

STEP 3.5
FULLY TIGHTEN
FAS0838 &
FAS0861
(02 PLACES)
1/2" SOCKET

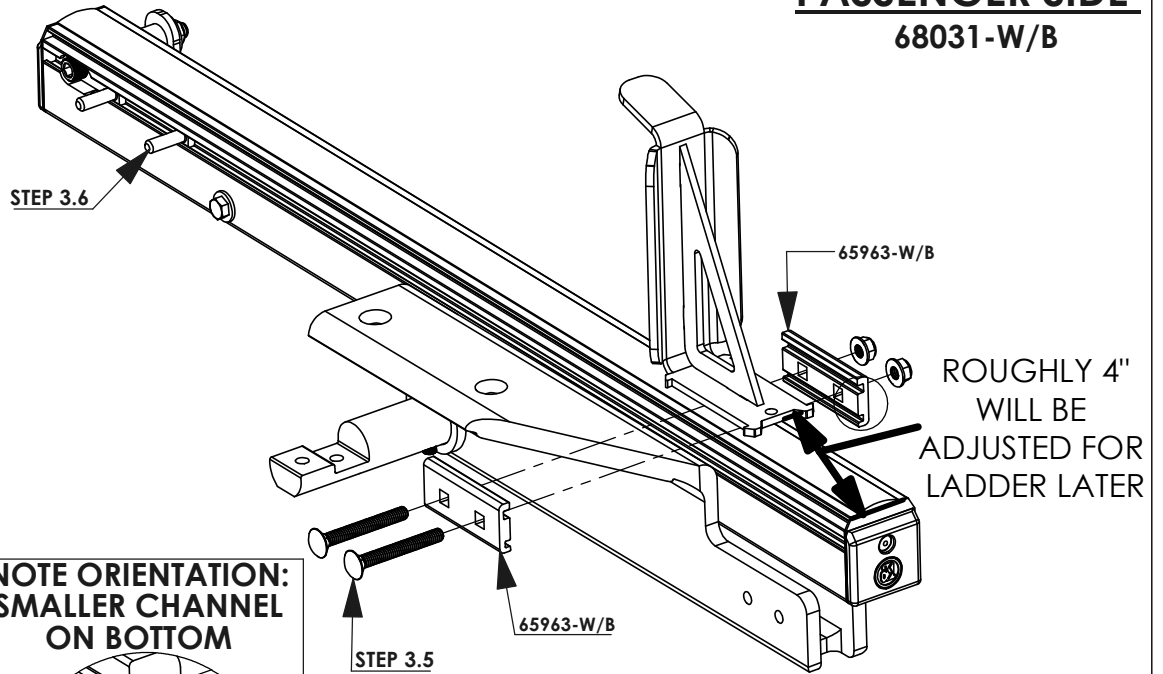

NOTE ORIENTATION:
SMALLER CHANNEL
ON BOTTOM

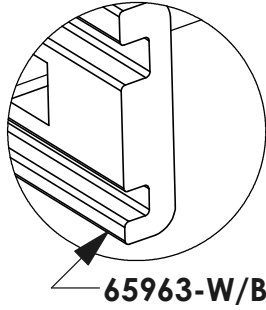

DRIVER SIDE

68013-W/B

STEP 3.6
FAS0035
SLIDE INTO SLOT
(02 PLACES)

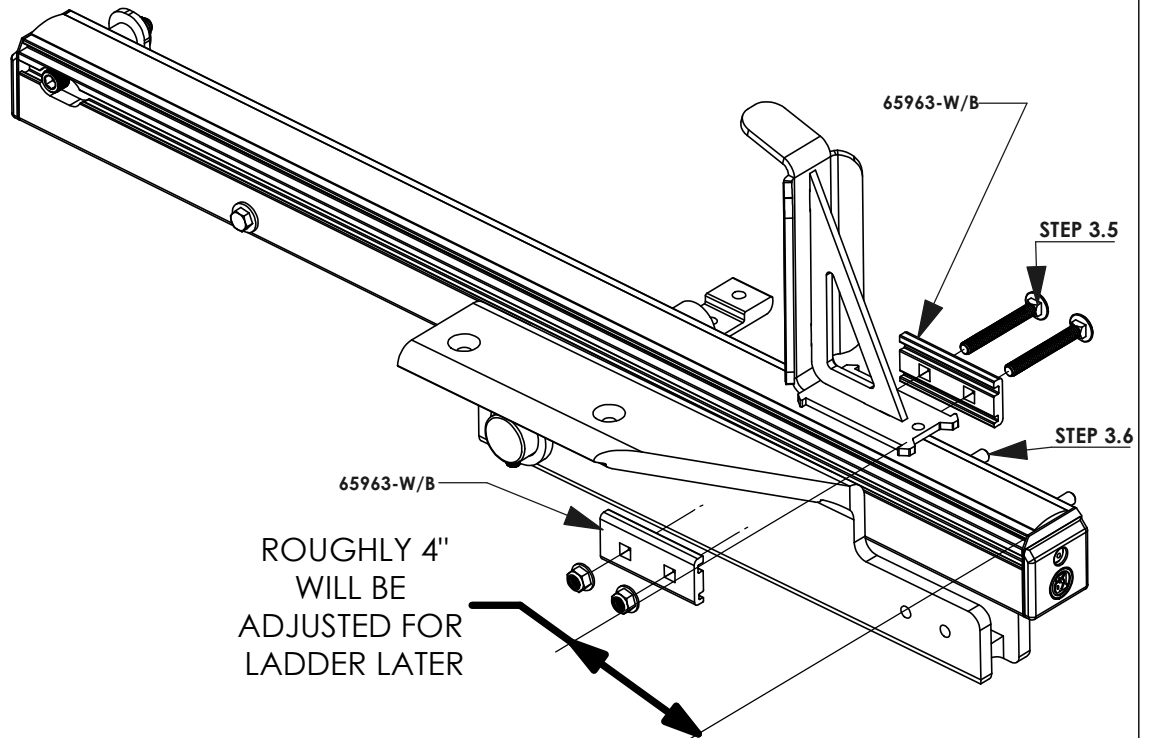



REFERENCE INSTALLATION GUIDE 68895 TABLES 1-3 INSTALLATION OF A.1, A.2, B.1, & B.2 SHOULD BE COMPLETE BEFORE PROCEEDING TO STEP 4

STEP 4 - INSTALL CARTRIDGES ON CROSSBOWS

STEP 4.1
SLIDE 63490 INTO
END OF
CROSSBOWS

C.1

STEP 4.2
LINE UP CORNERS
WITH END OF
CROSSBOW

STEP 4.3
FULLY TIGHTEN
(02) FAS0856,
(02) FAS0857, &
(02) 63490
(02 PLACES PER
SIDE)
3/16" ALLEN

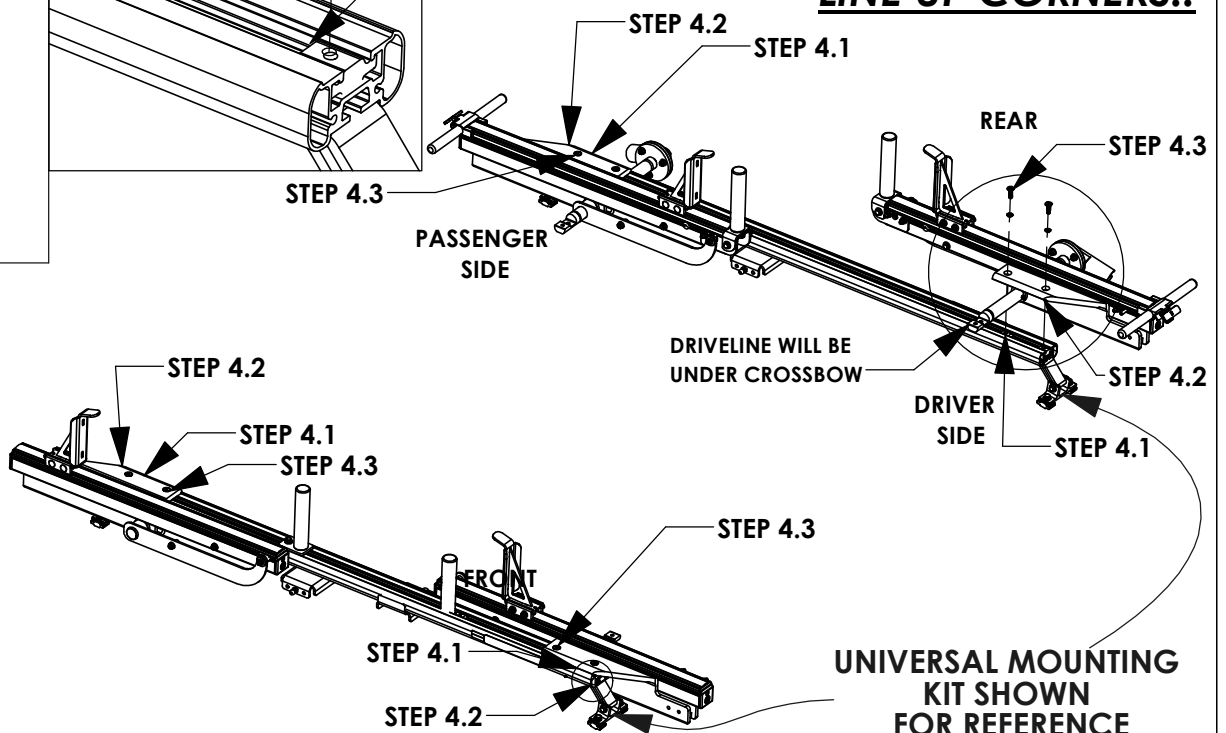
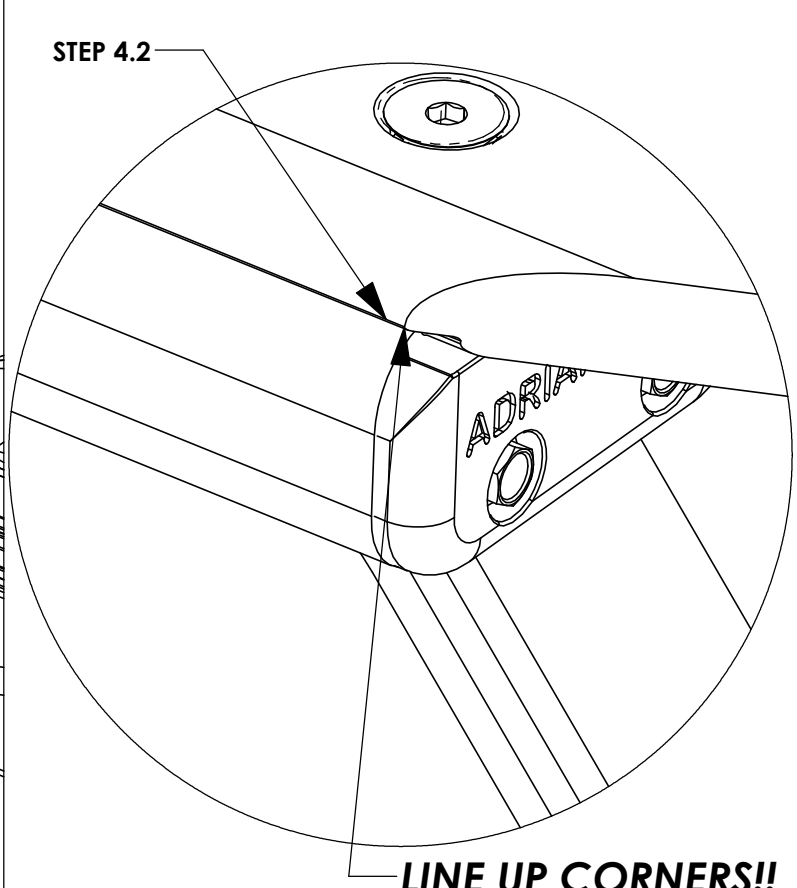
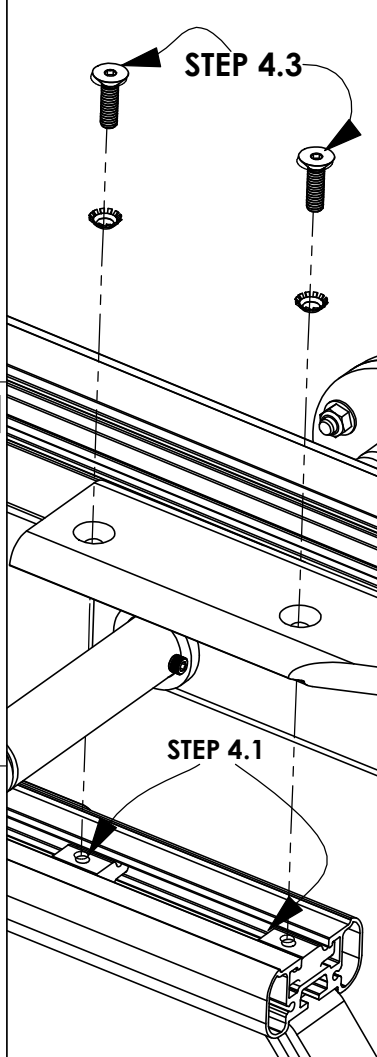

STEP 5 - INSTALL DRIVELINE

STEP 5.1
FULLY TIGHTEN
FAS0242, FAS0552
& FAS0861
(04 PLACES PER
SIDE)
1/2" WRENCH
1/2" SOCKET

BEST PRACTICE:
WHEN INSTALLING
BOLTS OPEN RACK
ROUGHLY 45
DEGREES FOR
EASIER ACCESS &
INSTALLATION

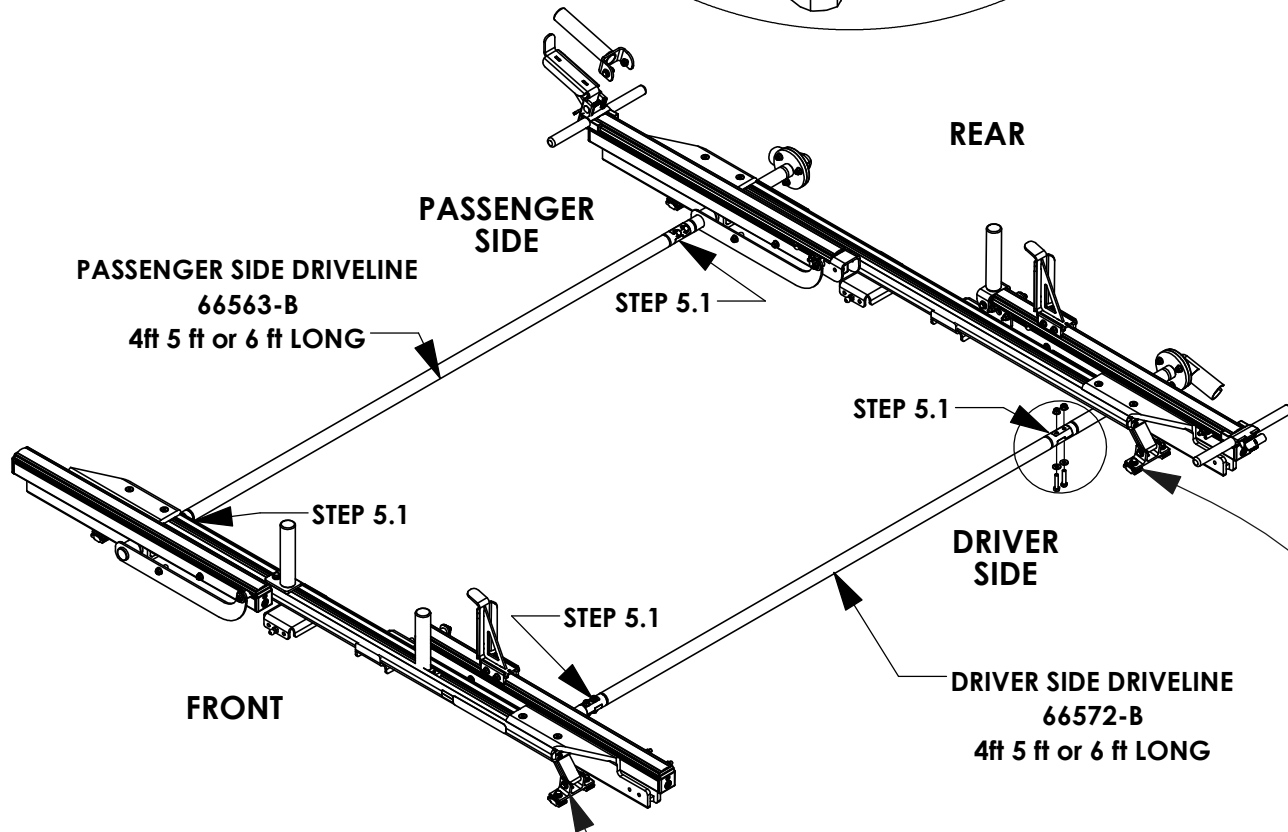
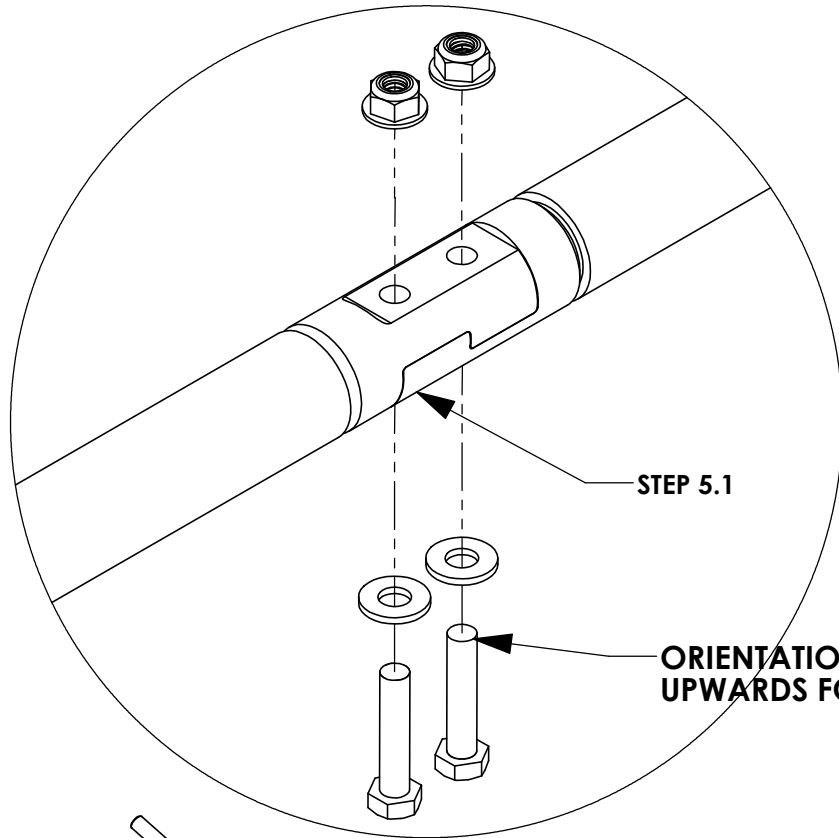

UNIVERSAL MOUNTING
KIT SHOWN
FOR REFERENCE

STEP 6 - DEPLOY RACK & INSTALL DAMPERS AND DROP DOWN HANDLE

Step 6.1
 ATTACH EXTENSION DAMPERS (48265) TO BALL STUDS.
ORIENTATION OF DAMPER MATTERS!!!
 (01 PLACE PER SIDE)

Step 6.2
 ATTACH COMPRESSION DAMPERS (58239) TO BALL STUDS.
ORIENTATION OF DAMPER MATTERS!!!
 (01 PLACE PER SIDE)

Step 6.3
 INSERT LOCKING PINS (34928-0) AFTER MOUNTING DAMPERS TO BALL STUDS
 (04 PLACES PER SIDE)

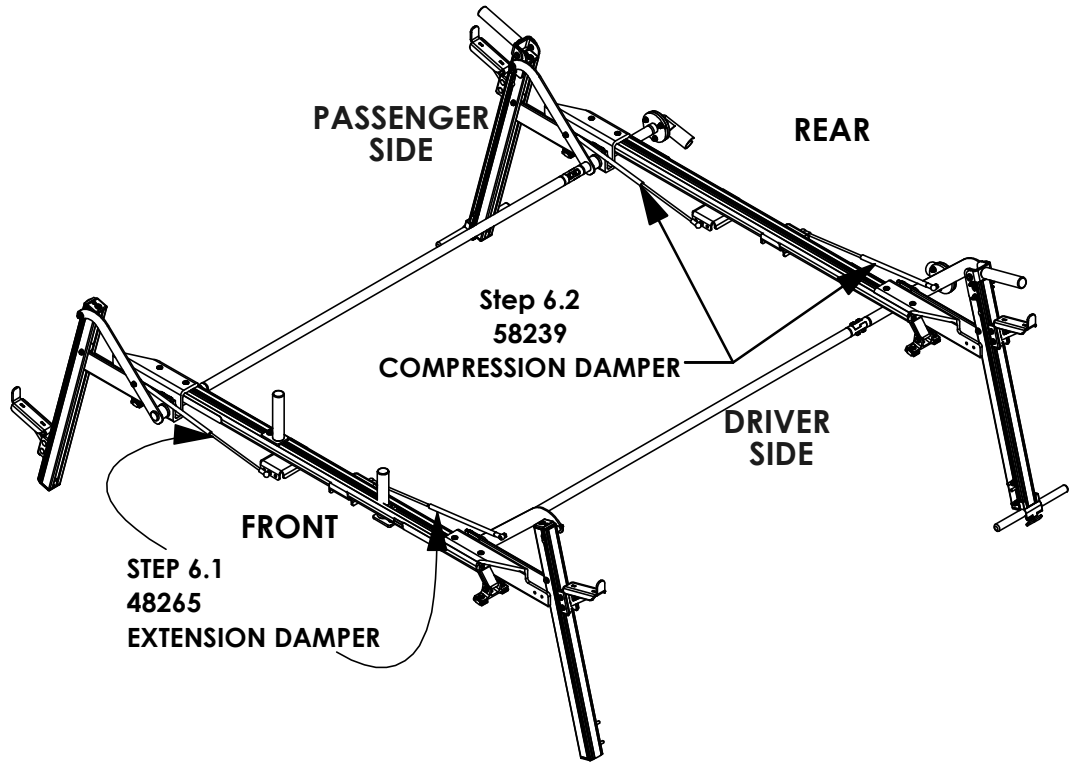

ORIENTATION OF DAMPER MATTERS!!!!

LARGE CYLINDER OF DAMPER ATTACHES TO ARM
 SMALL ROD END ATTACHES TO DAMPER BRACKET

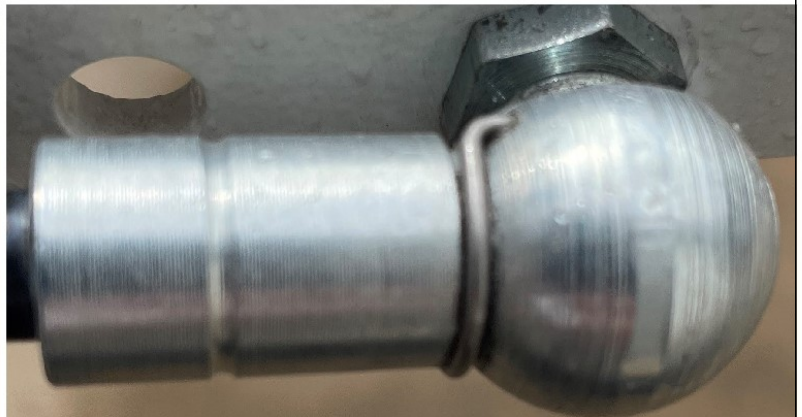
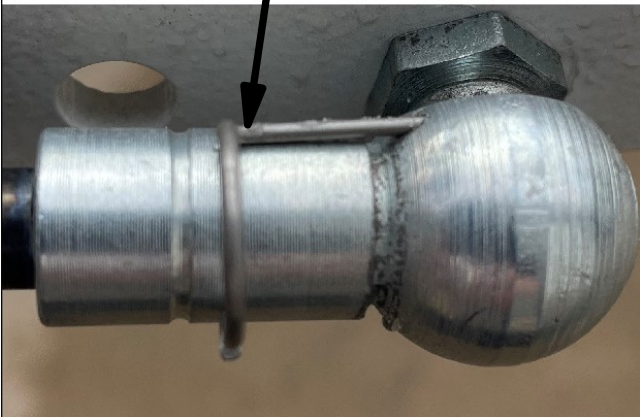
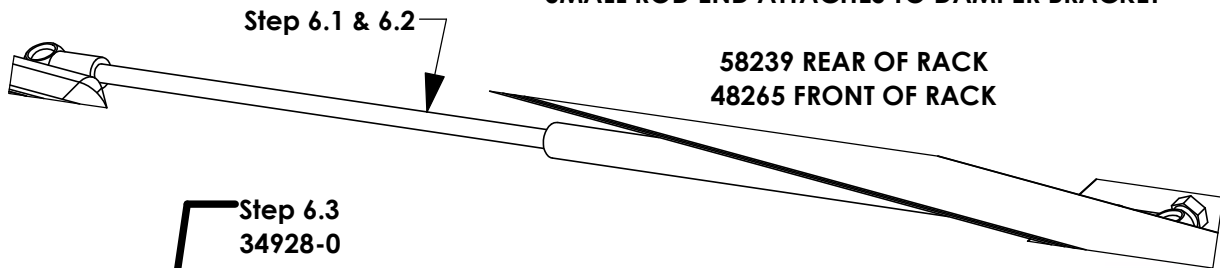

STEP 7 - WHILE RACK DEPLOYED INSTALL O.S. BAR

Step 7.1
FULLY TIGHTEN
FAS0861
(04 PLACES PER
SIDE)
1/2" SOCKET

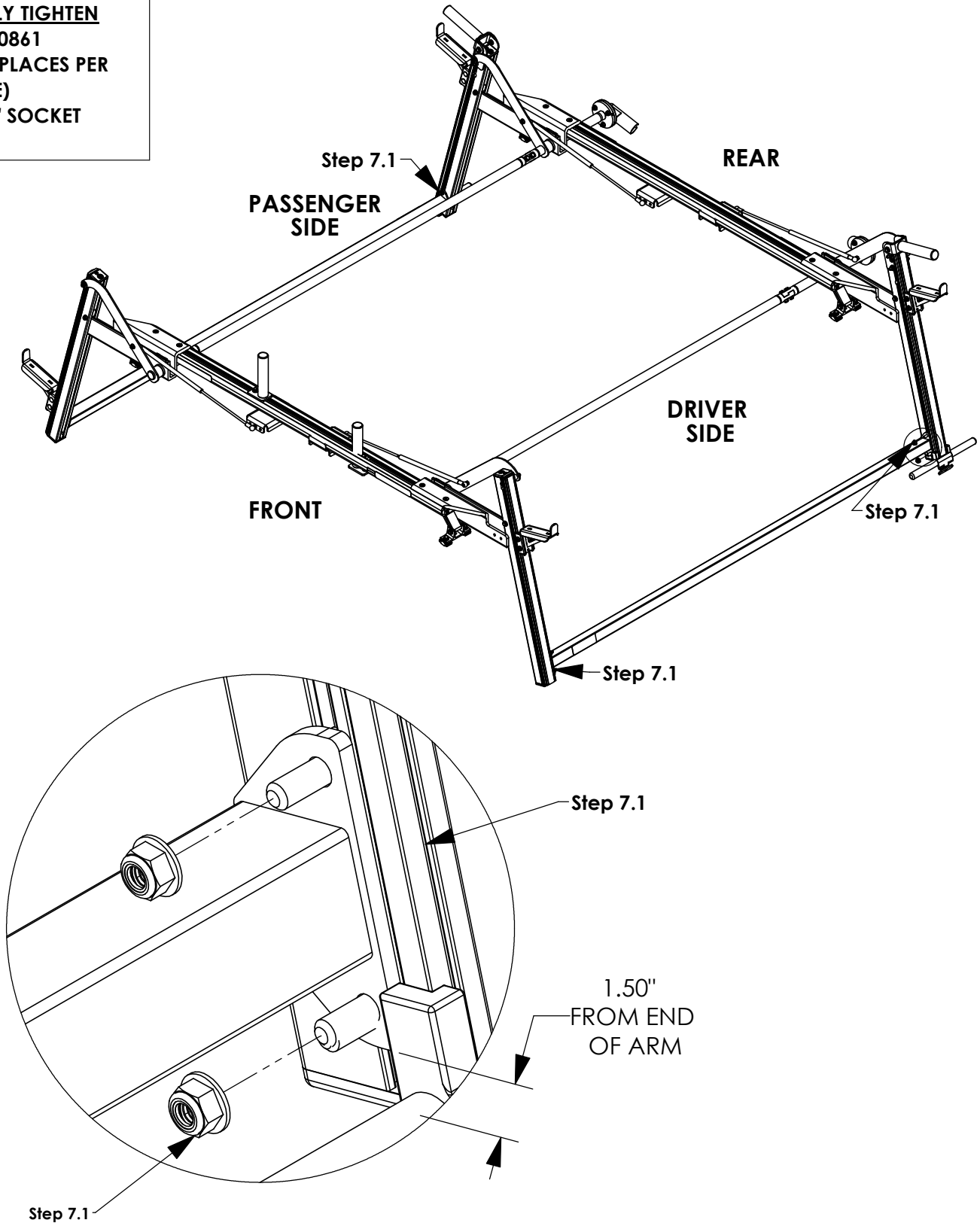

MAKE SURE ALL FASTENERS ARE TIGHTENED!!! INSTALLATION IS COMPLETE

STEP 8 - INSTALL CROSSBOW END CAPS

Step 8.1
FULLY TIGHTEN
(02) FAS0473, 65961
(02 PLACES PER SIDE)
3/8" SOCKET

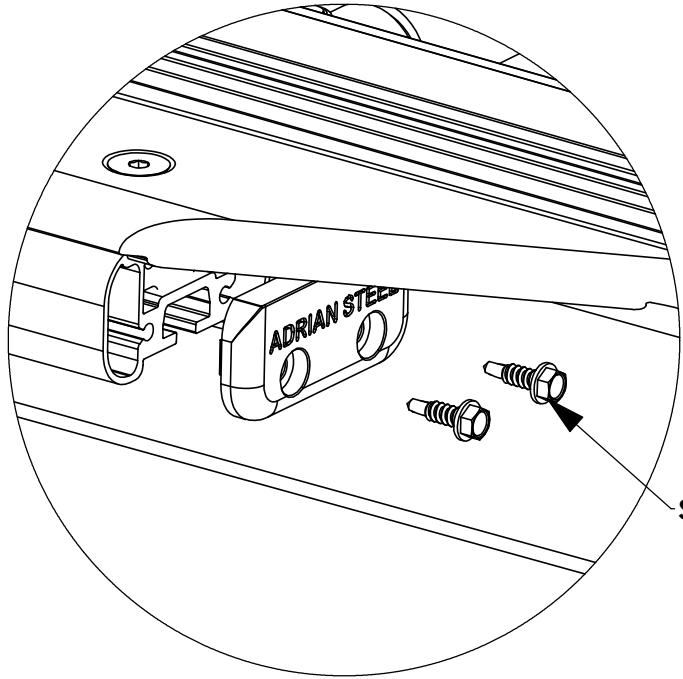

Step 9.1

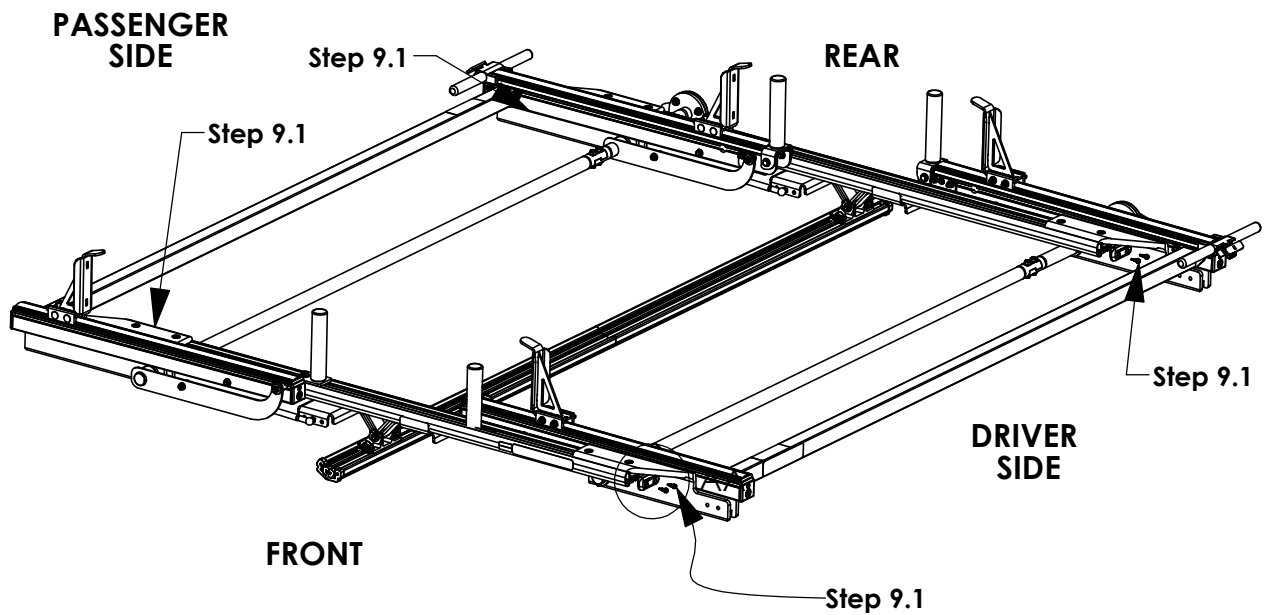

MAKE SURE ALL FASTENERS ARE TIGHTENED!!! INSTALLATION IS COMPLETE