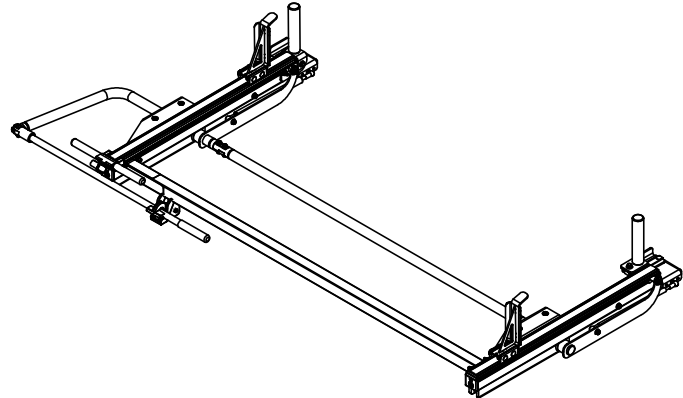

**ADRIAN STEEL®**

Cargo Management Solutions for Commercial Vehicles

# PROLIFT MAX DROP 5' PASSENGER SIDE LOW TOPPER LADDER RACKS

**PRODUCT WEIGHT****66.0 LBS****WIDTH X DEPTH X HEIGHT****82.00" X 32.00" X 4.00"****CAPACITY****SINGLE LADDER****COLOR****WHITE/BLACK****CATALOG NUMBER****PLMDPSLT5W, PLMDPSLT5B**

## PRODUCT FEATURES

ProLift™ Max Drop LOW Topper racks can be used on ADRIAN STEEL BIFF, LEER, UNICOVER and ARE truck toppers with bed lengths from 6'2" - 6'10" with appropriate rail kit, crossbow kit and mounting bracket kit. Use rail kits, crossbow kits, and mounting bracket kits listed in the table below to create new rack combinations. These racks include an attached handle.

The Max-Drop ProLift™ has a single function that lowers the ladder to a single set height and a secondary function that lowers the rear of the ladder even further to a safer more ergonomic height. Most similar to our previous DDLR drop-down series.

Unicover Toppers will use roof rail kits ending in UC (Ex. 4'6" Unicvoer topper would use RRKTOP55UC)

Ignore the roof rail kit when ordering racks for ASC BIFF toppers as they ship with pre-installed rails.

### Commercial Part Numbers

Vehicle Platform	Bed Length	Bed Length (in)	Roof Rail Kit	Crossbow kit	Mounting Bracket Kit	Pro-Lift (Passenger Side)	Pro-Lift (Drivers Side)
All	6'2" - 6'10"	74" - 82"	RRKTOP74/UC	2BARTOPW	URMBK4W	PLSDPSLT5	PLSDDSLT5

**NOTE: CROSSBAR KIT IS DIFFERENT FOR COMBO WITH GRIPLOCK. IN THIS CASE, USE 2BAR53W/B**

SEE PAGE 2 FOR APPLICATION NOTES, ACCESSORIES AND OTHER PRODUCTS THAT WORK WITH THIS UNIT.



# **PROLIFT MAX DROP 5' PASSENGER SIDE LOW TOPPER LADDER RACKS**

## **CATALOG NUMBER**

**PLMDPSLT5W, PLMDPSLT5B**

## **PRODUCT APPLICATION**

**TOPPER PROLIFT LADDER RACKS ARE FOR USE ON PICKUP TRUCK BED TOPPERS, AVAILABLE IN 4 FT, 5 FT, AND 6 FT LENGTHS FOR ALL DIFFERENT SIZE TRUCK BEDS.**

**Reduce back and shoulder injuries while loading/unloading ladders by eliminating the need to climb on bumpers and tires to reach the cargo on the roof of your vehicle.**

**The ProLift™ uses unique, patent-pending, mechanical advantages, and high-performing spring assist struts to raise and lower ladders with an almost effortless pull.**

## **ACCESSORIES THAT WILL WORK WITH THIS PRODUCT**

CATALOG NUMBER	DESCRIPTION (smart)
RRKTOP74	ROOF RAIL KIT, TOPPER, 74"
RRKTOP74UC	ROOF RAIL KIT, TOPPER, 74" UNICOVER
2BARTOPW / B	2BAR UTILITY RACK, TOP
2BAR53W / B	2BAR, CROSSBOW, 53"
URMBK4W / B	UTILITY, MNT BKT KT, RAIL
PLMDDSLT5W / B	PROLIFT, MAX, DS, LOW TOP, 5'
GL-CVDSW / B	GRIP-LOCK, COMP VAN DS

INSTR. NUMBER : <b>69483</b>	PG: <b>1</b>	REV: <b>A</b>
PART NUMBER • <b>Max Drop ProLift - Low &amp; Mid-Roof</b>		
PART • ProLift Low & Mid-Roof DESC. • Adjustment Instructions		

**Step 2: With 1/2" Socket loosen nut, slide post so that it is snug against ladder  
Tighten nut**

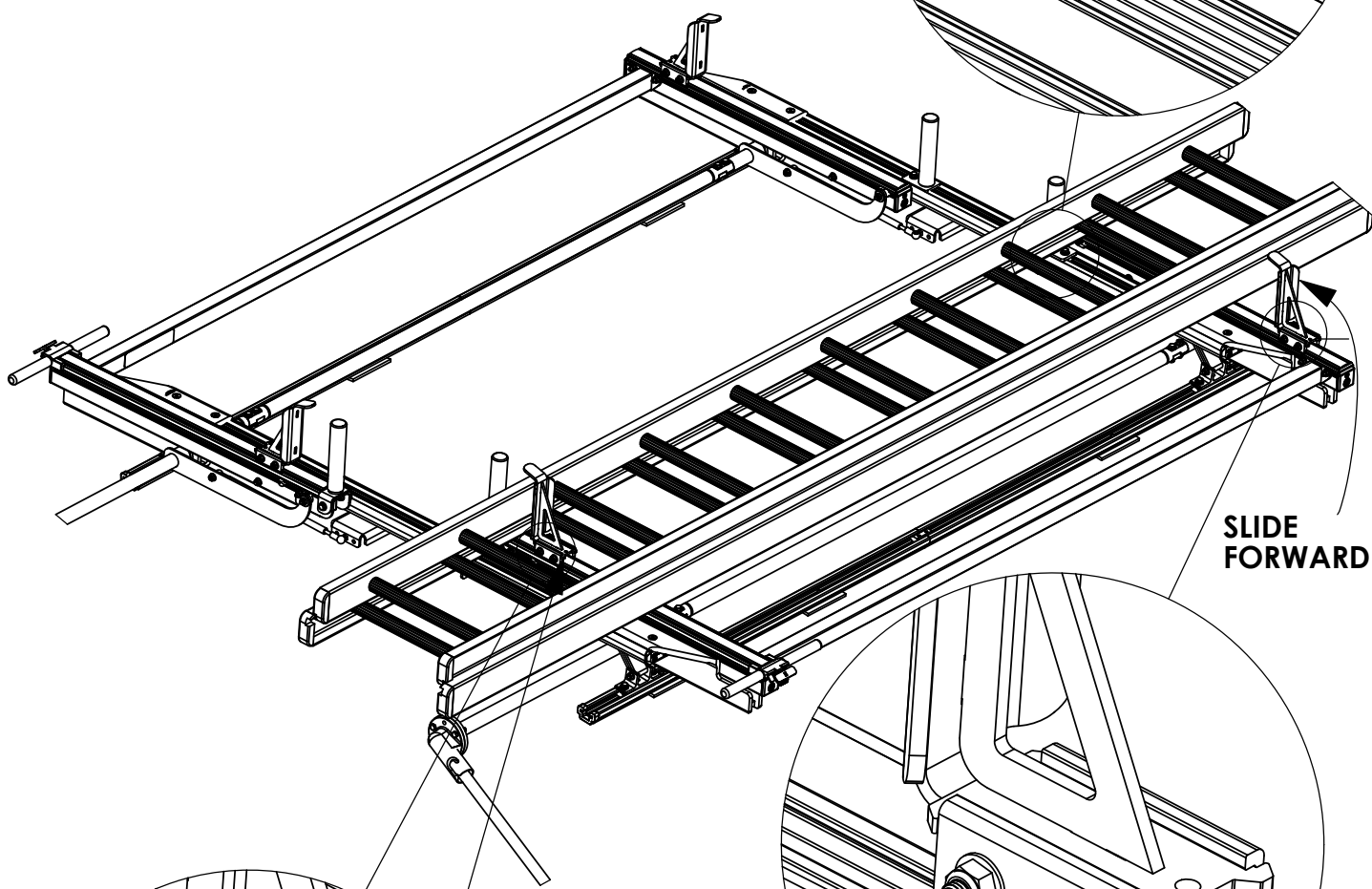

**SLIDE FORWARD**

**SLIDE FORWARD**

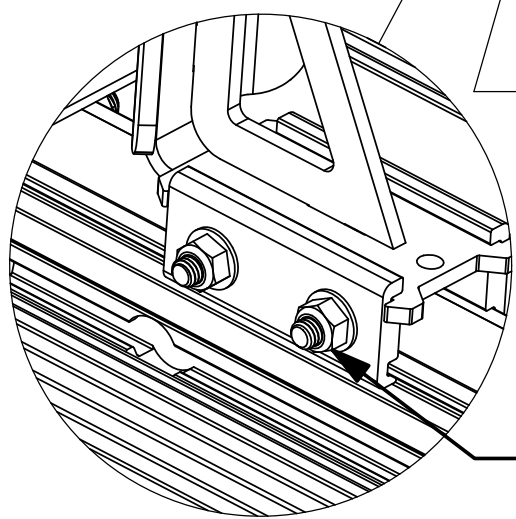

**Step 1: With 1/2" Socket loosen nuts (x2) slide clamp so that it is snug against ladder  
Tighten nuts (X2)**

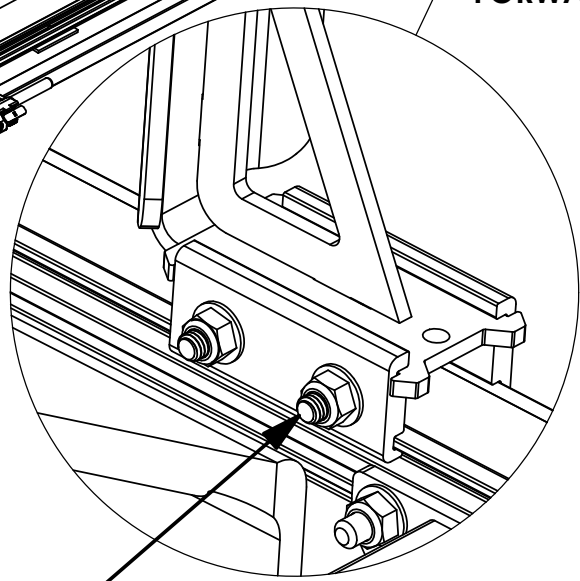

**Step 3: With 1/2" Socket loosen nuts (x2) slide clamp so that it is snug against outside of ladder  
Tighten nuts (X2)**

**Once all brackets are adjusted operate rack to make sure clamps are not too tight**

INSTR. NUMBER	PG:	REV:	ITEM NO.	PART NUMBER	DESCRIPTION	PLMDPSLT	PLMDDSLT
<b>: 70119</b>	<b>1</b>	<b>B</b>	1/15	70106-W	PROLIFT,LMT,DR ASM,PS,R,W	1	-
			2/16	68031-W	DROP DOWN FRONT ARM ASSM PS, WHITE	1	-
<b>PART NUMBER : PLMDPSLT &amp; PLMDDSLT</b>			3	68037-B	CLAMP PAD, 6.5", BLACK	2	2
<b>PART • PROLIFT,MAX,PS,LT DESC. • &amp; PROLIFT,MAX,DS,LT</b>			3/17	66572-B	DROP DOWN, CS CENTER DRIVELINE, BLK	1	-
			5	66611-B	DROP DOWN, PIVOT HANDLE, BLK	1	1
			6	48265	DAMPER ASSEMBLY	1	1
			7	58239	COMPRESSION DAMPER	1	1
			8	65963-W	STOP CLAMP, WHITE	4	4
			9	68186-W	PROLIFT INNER POST, WHITE	1	1
			10	68196-W	PROLIFT MAX DROP STOP, WHITE	1	1
			11	68628-W	PROLIFT HR DAMPER MOUNT, WHITE	2	2
			12	68180-W	DROP DOWN LATCH BRACKET, WHITE	1	1
			13	25340-0	HANDLE LATCH-STD	1	1
			14	72698-W	PL, 6' DS, OS BAR W/ LATCH CLAMP, WHITE	1	1
			15	70107-W	PROLIFT,LMT,DR ASM,PS,R,W	-	1
			16	68031-W	DROP DOWN FRONT ARM ASSM DS, WHITE	-	1
			17	6563-B	DROP DOWN, CS CENTER DRIVELINE, BLK	-	1

- PART NUMBERS WITH "-W" SUFFIX ARE PAINTED WHITE  
- FOR BLACK MOUNTING KITS, REPLACE "-W" PARTS WITH "-B" PARTS

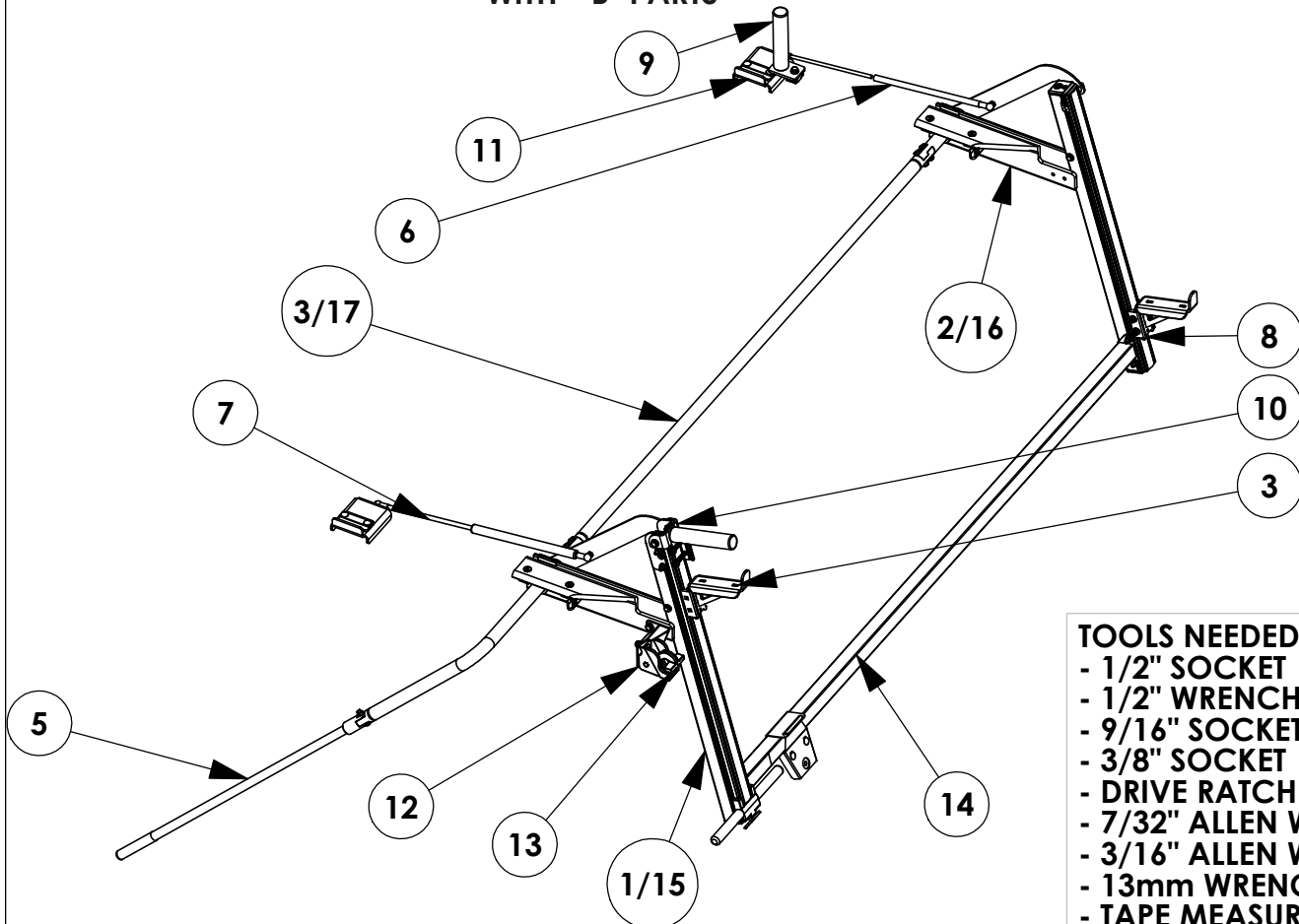

- TOOLS NEEDED:**
- 1/2" SOCKET
  - 1/2" WRENCH
  - 9/16" SOCKET
  - 3/8" SOCKET
  - DRIVE RATCHET
  - 7/32" ALLEN WRENCH
  - 3/16" ALLEN WRENCH
  - 13mm WRENCH
  - TAPE MEASURE
  - RUBBER Mallet
  - IMPACT DRIVER

**\*\*IF BUILDING A DUAL SIDED RACK BUILD BOTH SIDES IN PARALLEL FOR EACH STEP. IF BUILDING SINGLE SIDED REFERENCE ONLY THAT SIDE WHEN BUILDING.\*\***

**GET TO KNOW THE VEHICLE** - AT THE BEGINNING OF ANY INSTALLATION, CHECK THE LOCATION OF THE FUEL TANK, FUEL LINES, BRAKE LINES, HIGH VOLTAGE BATTERIES AND WIRING HARNESSSES TO AVOID INJURY OR PROPERTY DAMAGE FROM TOOL CONTACT.

**SEAL ALL EXTERIOR HOLES** - ALL INSTALLATION HOLES SHOULD BE SEALED WITH BUTYL TAPE OR SILICON TO PREVENT WATER AND EXHAUST GASES FROM ENTERING THE VEHICLE.

**CONTROL DRILL DEPTH** - TO AVOID DAMAGE TO THE VEHICLE, USE A DRILL STOP OR CLEARED STEP BIT WHEN DRILLING INSTALLATION HOLES.

**ALWAYS ADD PRIMER** - WHEN ADDING INSTALLATION HOLES BE SURE TO USE A SELF-ETCHING PRIMER TO PREVENT CORROSION, FASTENER FAILURE AND INJURY.

**MOUNTING POINTS MUST HAVE METAL-TO-METAL CONTACT** - USE PROVIDED MOUNTING SPACERS TO ACCOMMODATE FOR VEHICLE FEATURES, CARPET OR SUBFLOORS.

**PROVIDE CLEARANCE FOR SPACERS** - IF THE INSTALLATION VEHICLE CONTAINS A CARPET OR SUBFLOOR, USE A 1-3/16" DIAMETER CARPET CUTTER (P/N: 31183-0) AT ALL MOUNTING LOCATIONS TO OPEN UP ROOM FOR SPACERS.

**CHECK SPACER ORIENTATION** - BE SURE THAT THE INDENT IN THE SPACER COVERS THE PLUSNUT HEAD; THIS ENSURES THE MOST METAL-TO-METAL CONTACT AND REDUCES VIBRATION.

**PLUSNUT INSTALLATION** - A PLUSNUT GUN IS RECOMMENDED FOR PLUSNUT INSTALLATION FOR ITS PRODUCTION SPEED. HOWEVER, A PLUSNUT SETTING TOOL CAN ALSO BE USED (P/N: 22200-0).

**THRU-BOLT CLEARANCE** - WHEN USING A THRU-BOLT AT ANY MOUNTING LOCATION, BE SURE THAT YOUR HOLE HAS 1/16" CLEARANCE.

**BEST PRACTICE: ORGANIZE ALL FASTENERS & VERIFY THAT ALL ARE ACCOUNTED FOR**

PAGE:

**3**

**FASTENERS AND HARDWARE USED**

**BAG REFERENCE: BAG6820 & BAG72688**

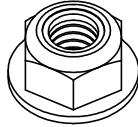

FAS0861  
NUT,HEX NLK FLG 5/16-18  
QTY: 20

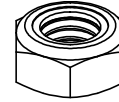

FAS0399  
NUT,HEX NLK LT 3/8-16  
QTY: 02

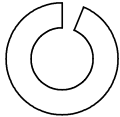

FAS0588  
WASHER,LCK SPLIT 5/16  
QTY: 02

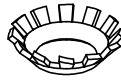

FAS0857  
WASHER,LCK EXT CS 5/16  
QTY: 04

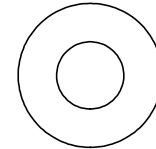

FAS0552  
WASHER,FLAT USS 5/16  
QTY: 07

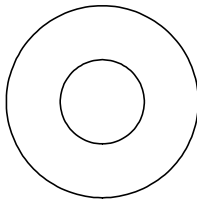

FAS0720  
WASHER,FLAT USS 3/8  
QTY: 01

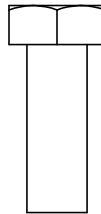

FAS0283  
SCREW,HH 5/16-18X.875  
QTY: 03

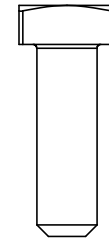

FAS0035  
BOLT,SQ HD 5/16-18X1.0  
QTY: 02

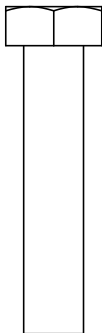

FAS0242  
SCREW,HH 5/16-18X1.5  
QTY: 04

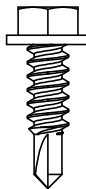

FAS0473  
SCREW,HH TEK #12X.75  
QTY: 04

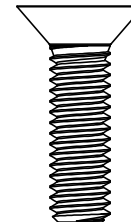

FAS0856  
SCREW,FHH 5/16-18X1.13  
QTY: 04

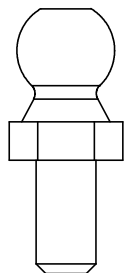

34927-0  
BALL STUD 13MM X 5/16-18  
QTY: 02



FAS0820  
SCREW,BHCS 3/8-16X1.00  
QTY: 01

**INTENTIONALLY LEFT BLANK**

**FASTENERS AND HARDWARE USED**

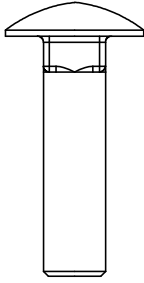

FAS0812  
BOLT,CRG 5/16-18X1.25  
QTY: 04

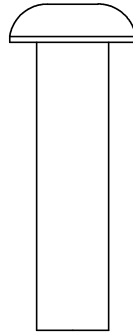

FAS0819  
SCREW,BHCS 3/8-16X1.5  
QTY: 01

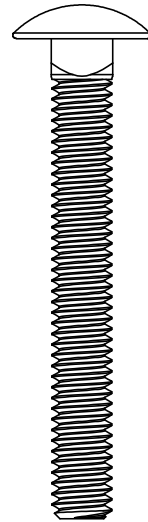

FAS0838  
BOLT,CRG 5/16-18X2.5  
QTY: 04

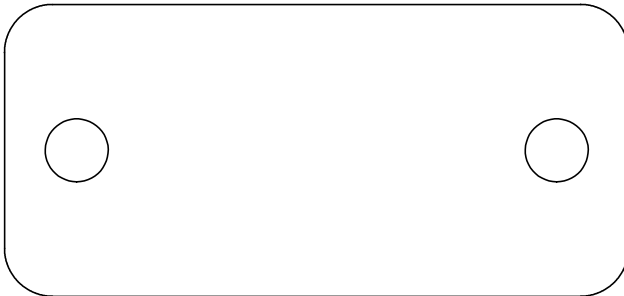

64831  
REAR ROLLER, SPACER  
QTY: 02

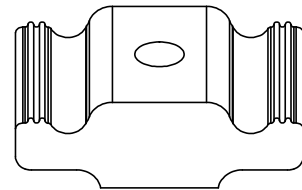

63490  
RAIL SLIDE, 1"  
QTY: 05



64830  
REAR ROLLER, BOLT PLATE  
QTY: 02



34928-0  
CLIP, SPRING, RETAINER, 13MM  
QTY: 04

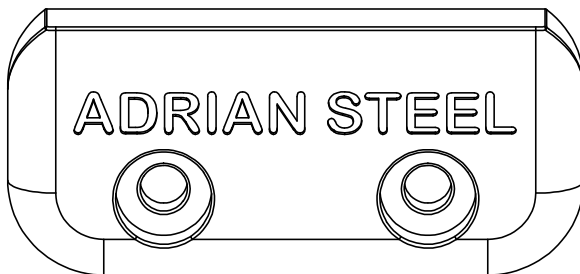

65961  
DROP DOWN END CAP  
QTY: 02

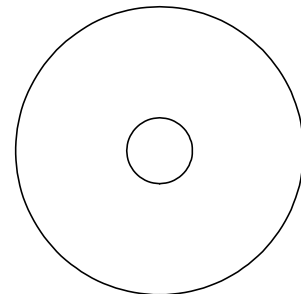

**DISCARD** FAS0603  
SCREW,HH 5/16-18X.875  
QTY: 01



**INTENTIONALLY LEFT BLANK**

**STEP 1 - MOUNT DAMPER BRACKETS**

**A.2**

**Step 1.1**  
**FULLY TIGHTEN**  
 34927-0 & FAS0861  
 (02 PLACES PER  
 SIDE)  
 13mm WRENCH  
 1/2" SOCKET

**STEP 1.2**  
**FULLY TIGHTEN**  
 (02) FAS0812,  
 64830, 64831, &  
 (02) FAS0861  
 (02 PLACES PER  
 SIDE)  
 1/2" SOCKET

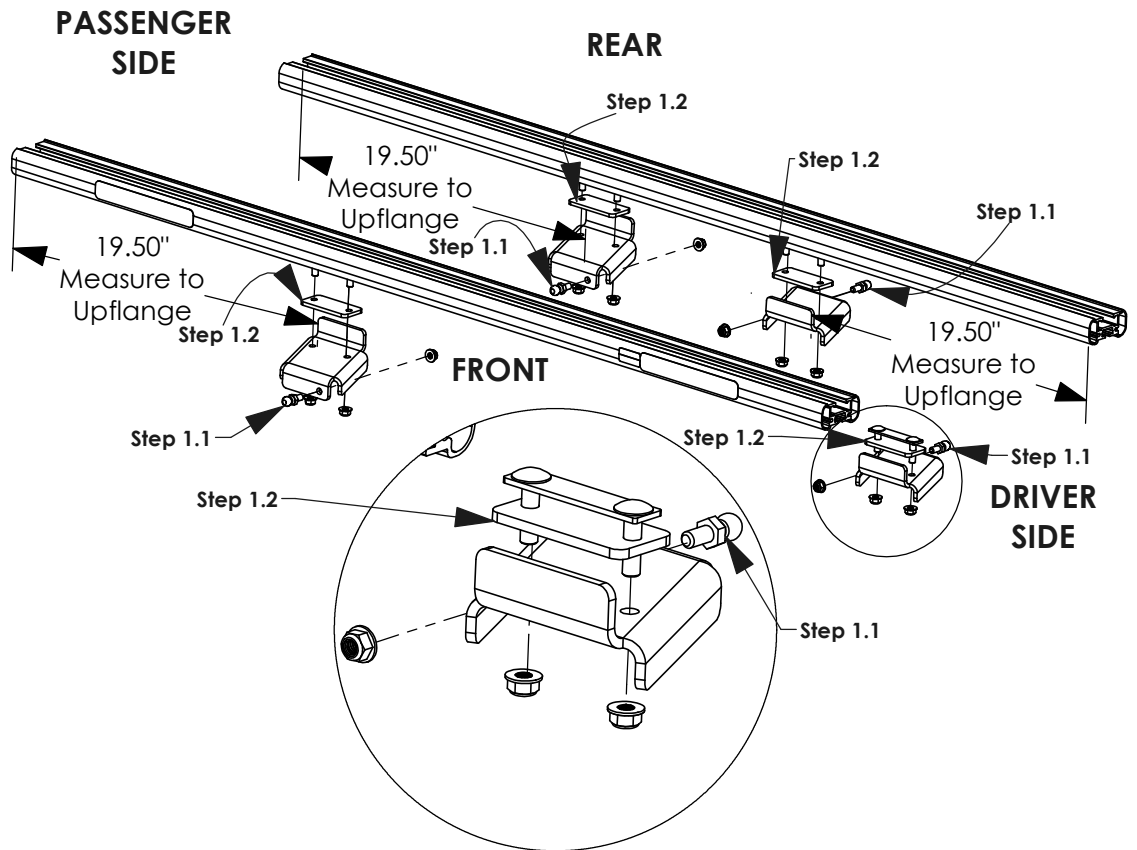

**STEP 2 - MOUNT INNER STOPS TO FRONT CROSSBOW**

**B.1**

**STEP 2.1**  
**FULLY TIGHTEN**  
 FAS0283, FAS0552,  
 & FAS0588, 63490  
 (01 PLACE PER  
 SIDE)  
 1/2" SOCKET

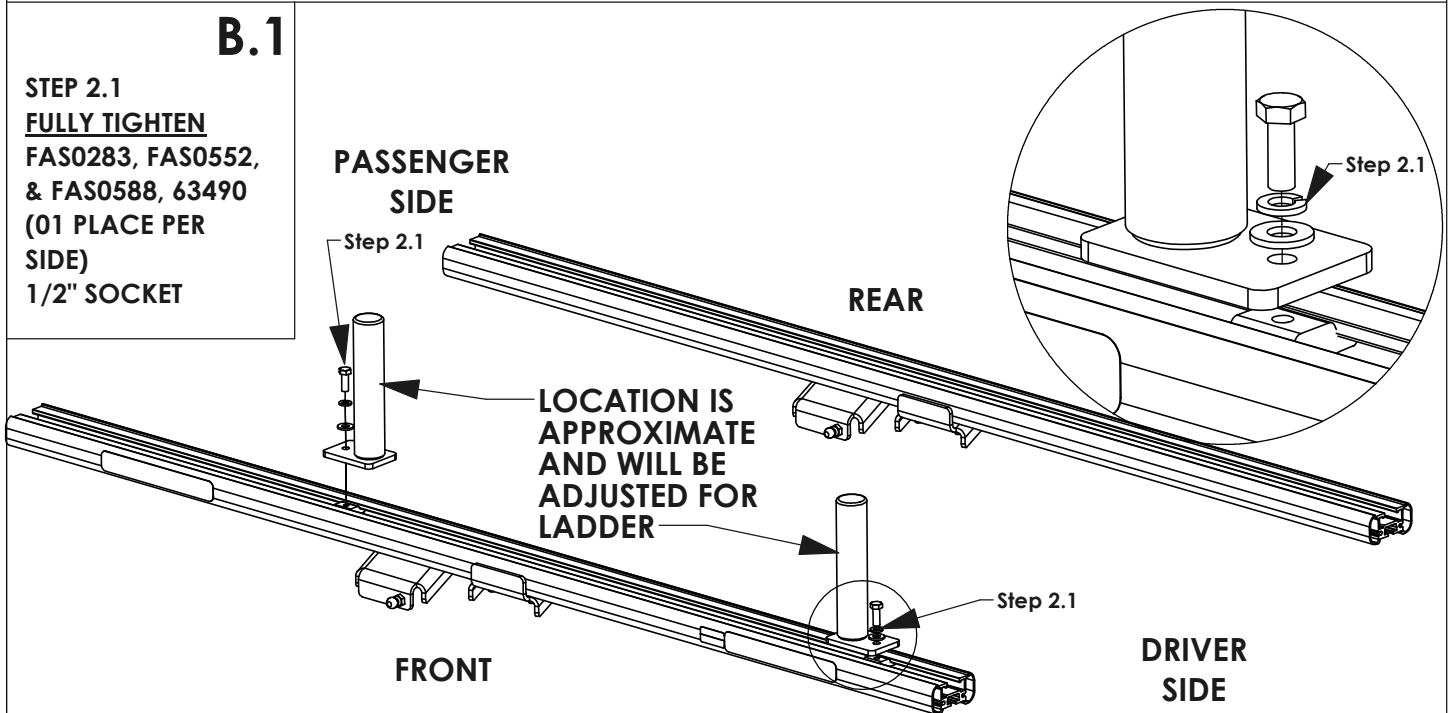

# STEP 3 - INSTALL CLAMPS AND HARDWARE ON DROP DOWN CARTRIDGES

## REAR SUB-ASSEMBLY

**STEP 3.1**  
**FULLY TIGHTEN**  
 FAS0283, FAS0552,  
 & FAS0861  
 (02 PLACES)  
 1/2" WRENCH  
 1/2" SOCKET

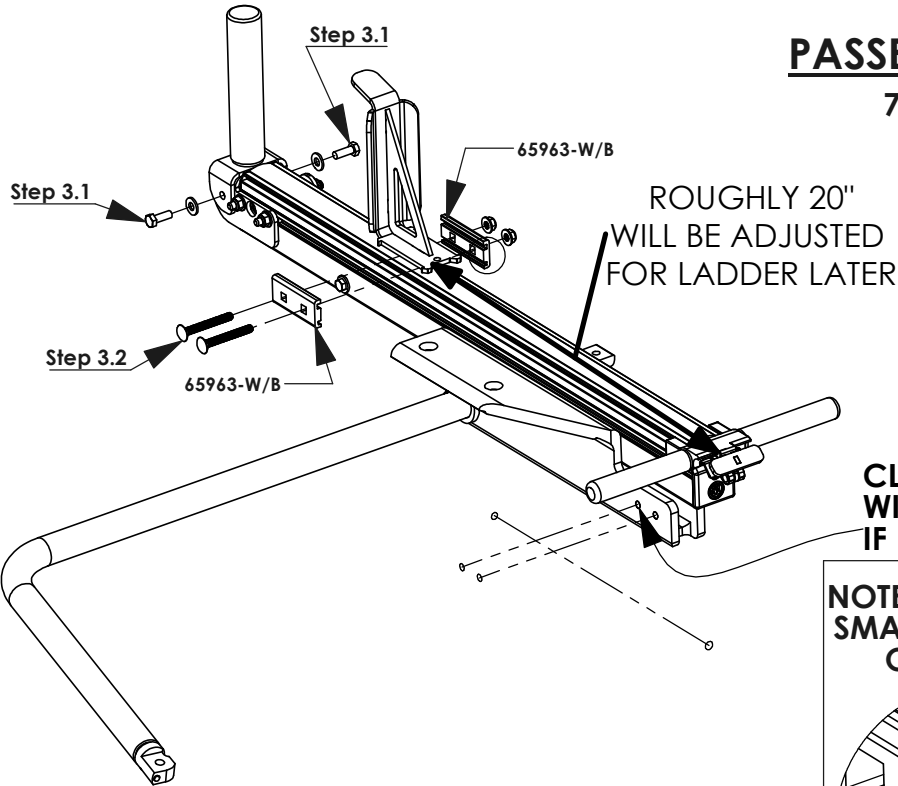

**NOTE ORIENTATION:**  
 SMALLER CHANNEL  
 ON BOTTOM

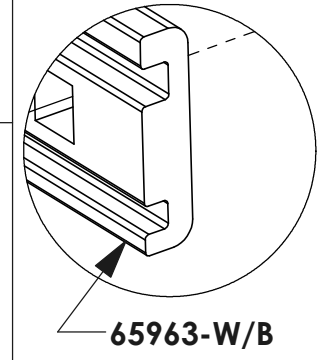

## DRIVER SIDE

  
 70107-W/B

**STEP 3.2**  
**FULLY TIGHTEN**  
 FAS0838 &  
 FAS0861  
 (02 PLACES)  
 1/2" SOCKET

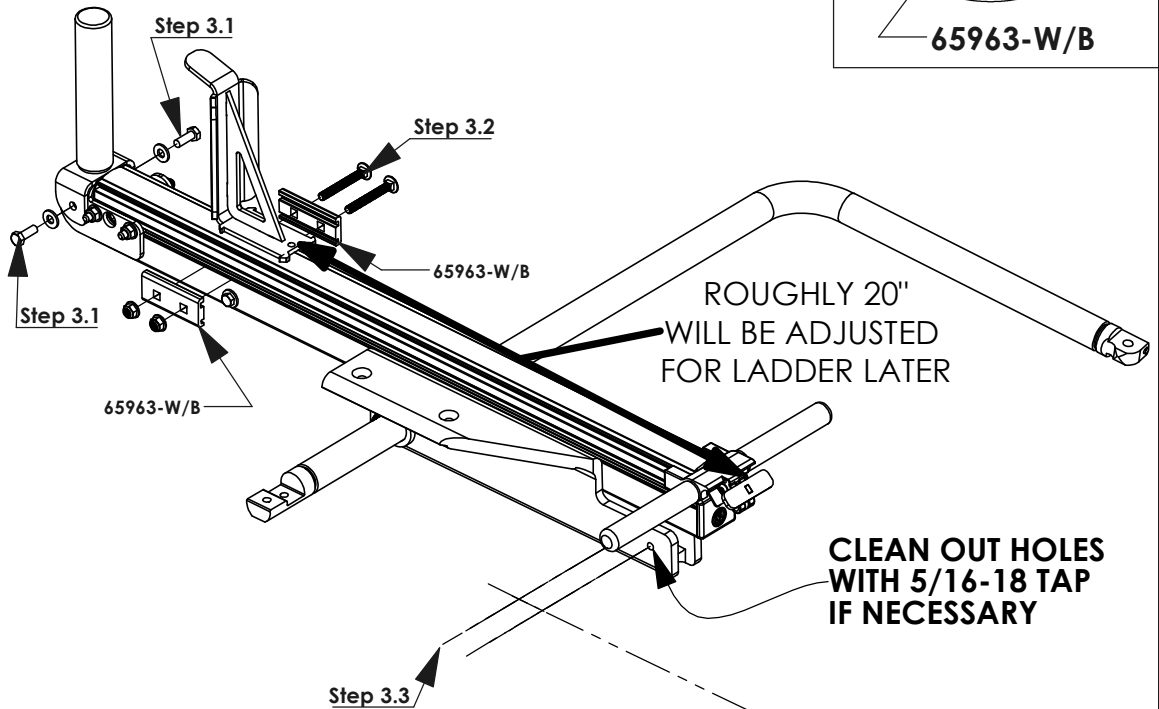

# FRONT SUB-ASSEMBLY

## PASSENGER SIDE

68031-W/B

**STEP 3.3**  
**FULLY TIGHTEN**  
**FAS0838 &**  
**FAS0861**  
**(02 PLACES)**  
**1/2" SOCKET**

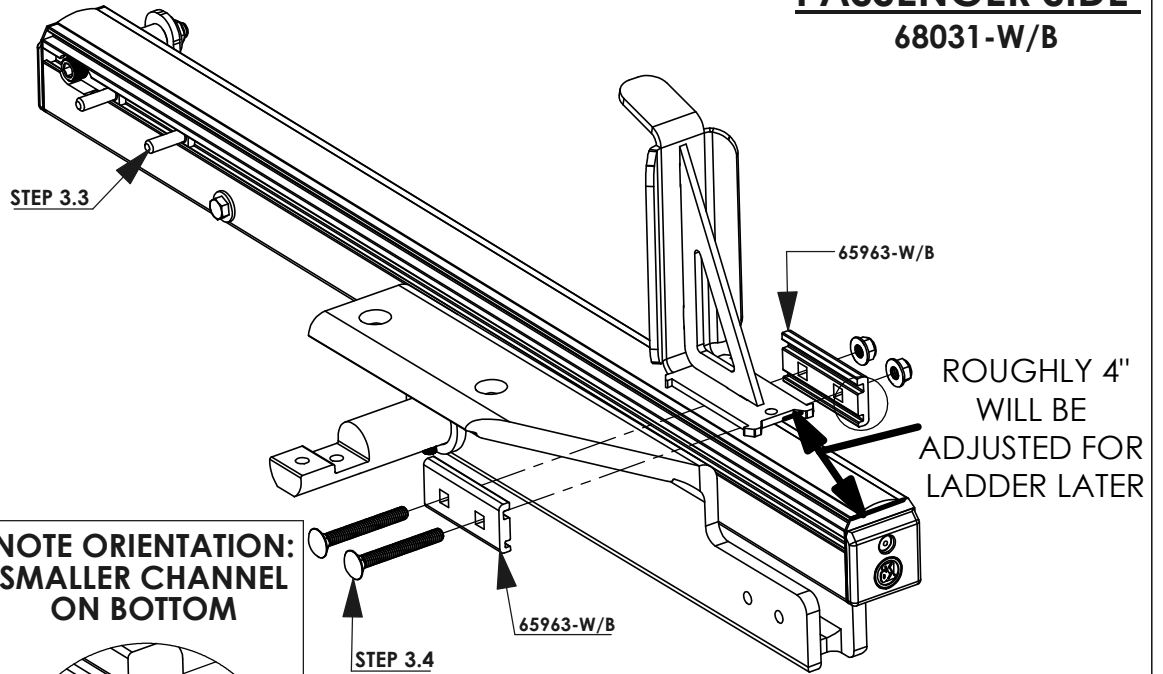

**NOTE ORIENTATION:**  
**SMALLER CHANNEL**  
**ON BOTTOM**

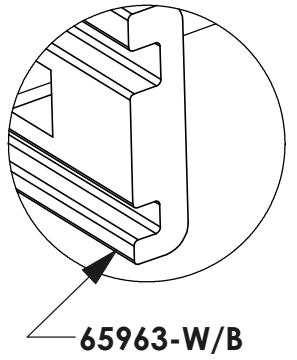

## DRIVER SIDE

68013-W/B

**STEP 3.4**  
**FAS0035**  
**SLIDE INTO SLOT**  
**(02 PLACES)**

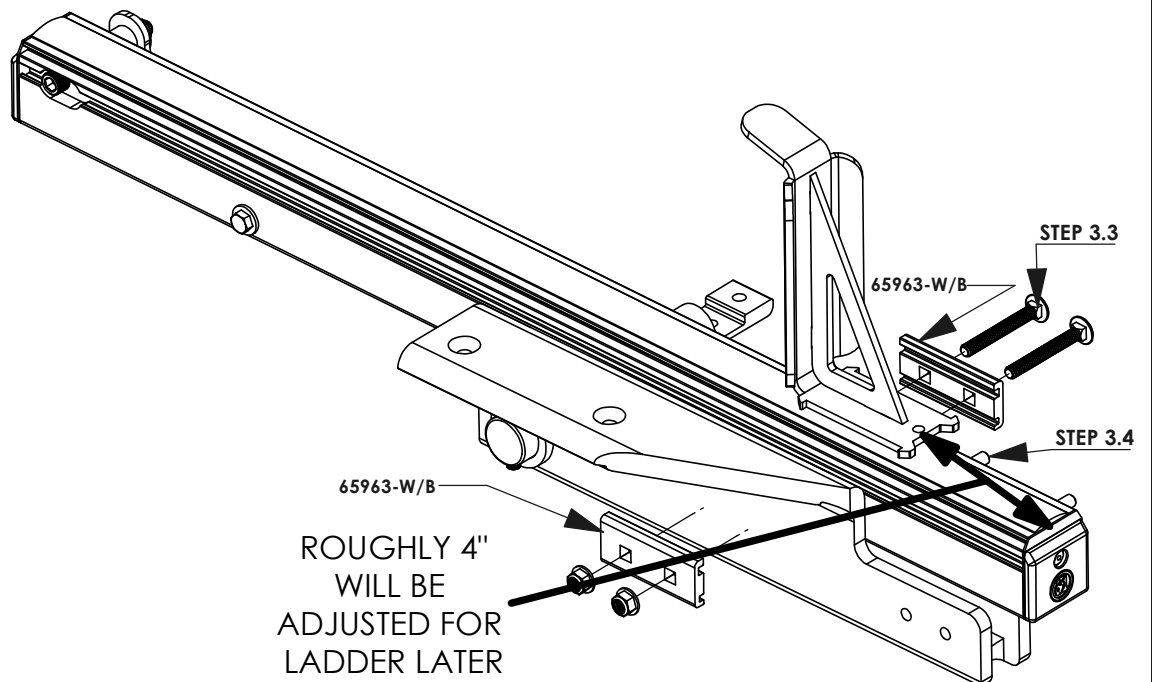



# REFERENCE INSTALLATION GUIDE 68895 TABLES 1-3 INSTALLATION OF A.1, A.2, B.1, & B.2 SHOULD BE COMPLETE BEFORE PROCEEDING TO STEP 4

## STEP 4 - INSTALL CARTRIDGES ON CROSSBOWS

**STEP 4.1**  
SLIDE 63490 INTO  
END OF  
CROSSBOWS

**C.1**

**STEP 4.2**  
LINE UP CORNERS  
WITH END OF  
CROSSBOW

**STEP 4.3**  
**FULLY TIGHTEN**  
(02) FAS0856,  
(02) FAS0857, &  
(02) 63490  
(02 PLACES PER  
SIDE)  
3/16" ALLEN

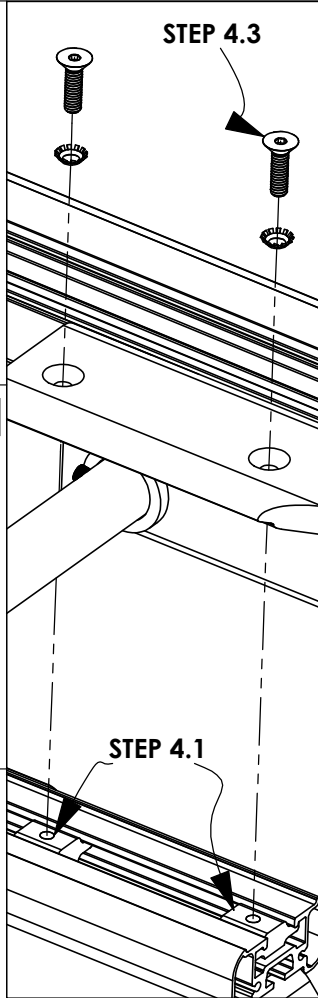

**LINE UP CORNERS!!**

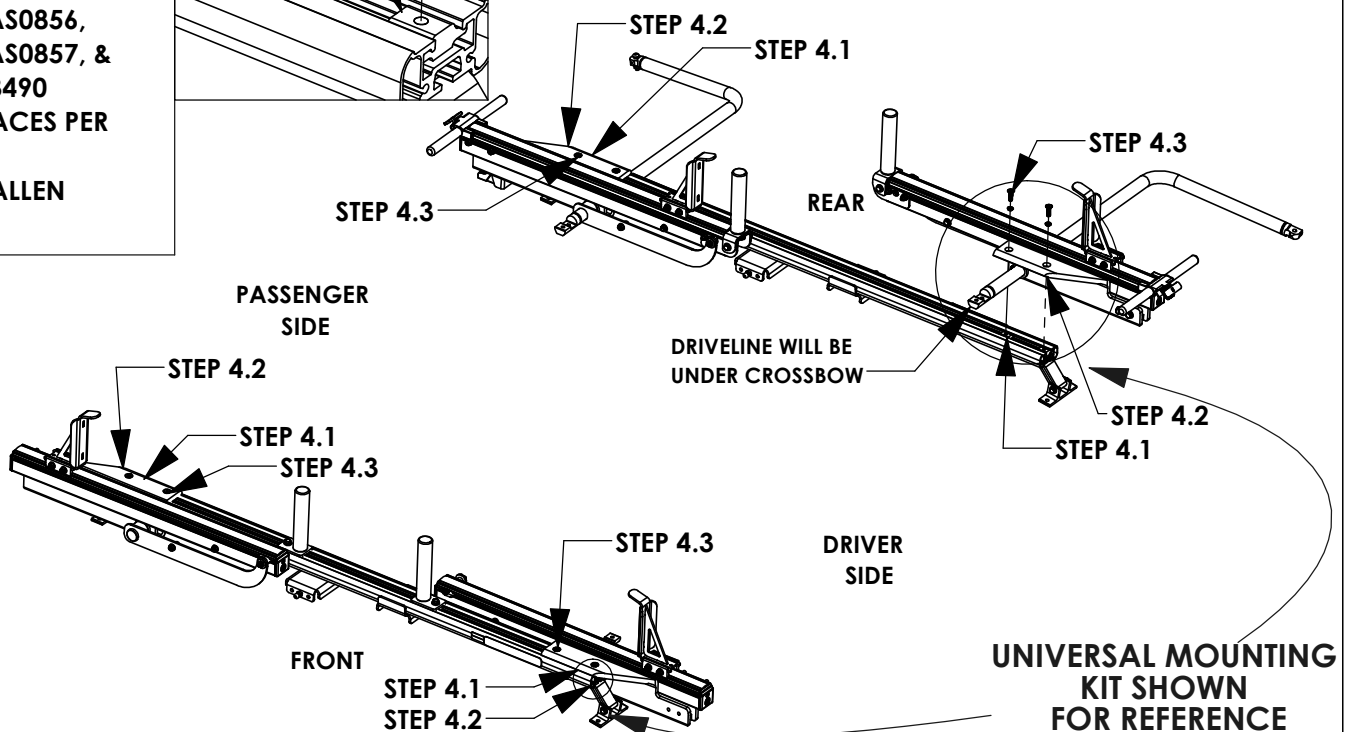

# STEP 5 - INSTALL DRIVELINE

**STEP 5.1**  
**FULLY TIGHTEN**  
**FAS0242, FAS0552**  
**& FAS0861**  
**(04 PLACES PER**  
**SIDE)**  
**1/2" WRENCH**  
**1/2" SOCKET**

**BEST PRACTICE:**  
**WHEN INSTALLING**  
**BOLTS OPEN RACK**  
**ROUGHLY 45**  
**DEGREES FOR**  
**EASIER ACCESS &**  
**INSTALLATION**

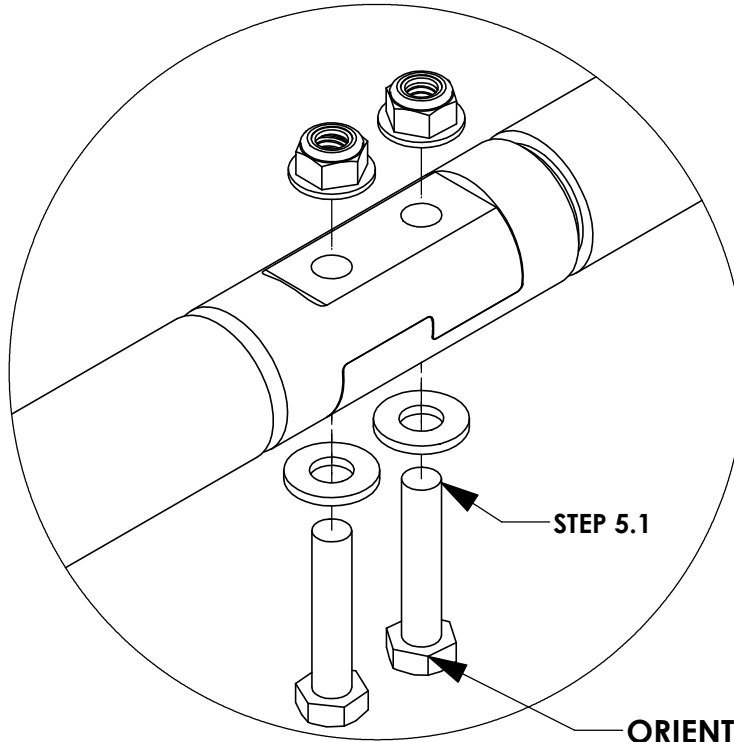

**ORIENTATION OF BOLTS IS UPWARDS FOR ASSEMBLY**

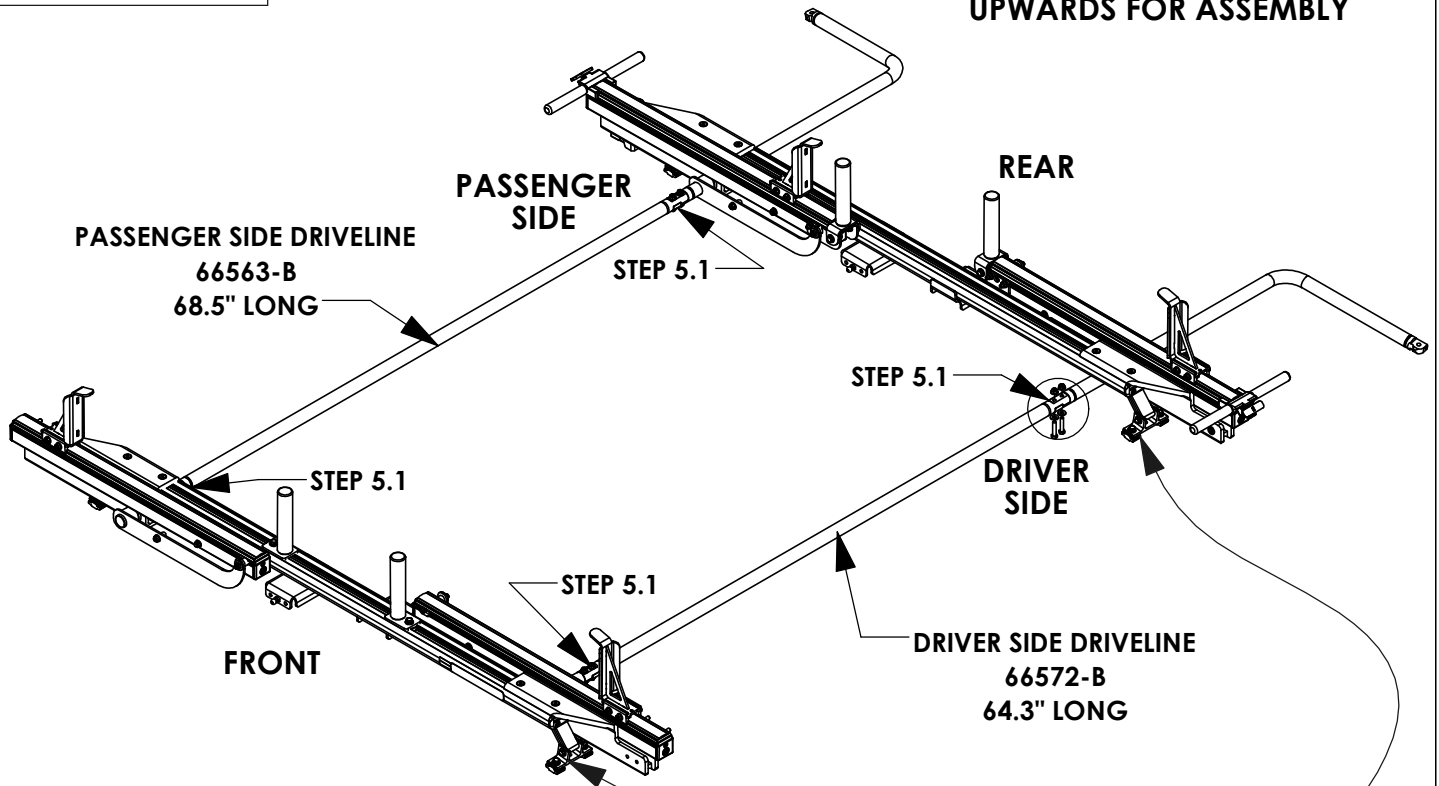

**UNIVERSAL MOUNTING**  
**KIT SHOWN**  
**FOR REFERENCE**

# STEP 6 - DEPLOY RACK & INSTALL DAMPERS AND DROP DOWN HANDLE

**Step 6.1**  
 ATTACH EXTENSION DAMPERS (48625) TO BALL STUDS.  
ORIENTATION OF DAMPER MATTERS!!!  
 (01 PLACE PER SIDE)

**Step 6.2**  
 ATTACH COMPRESSION DAMPERS (58239) TO BALL STUDS.  
ORIENTATION OF DAMPER MATTERS!!!  
 (01 PLACE PER SIDE)

**Step 6.3**  
 INSERT LOCKING PINS (34928-0) AFTER MOUNTING DAMPERS TO BALL STUDS  
 (04 PLACES PER SIDE)

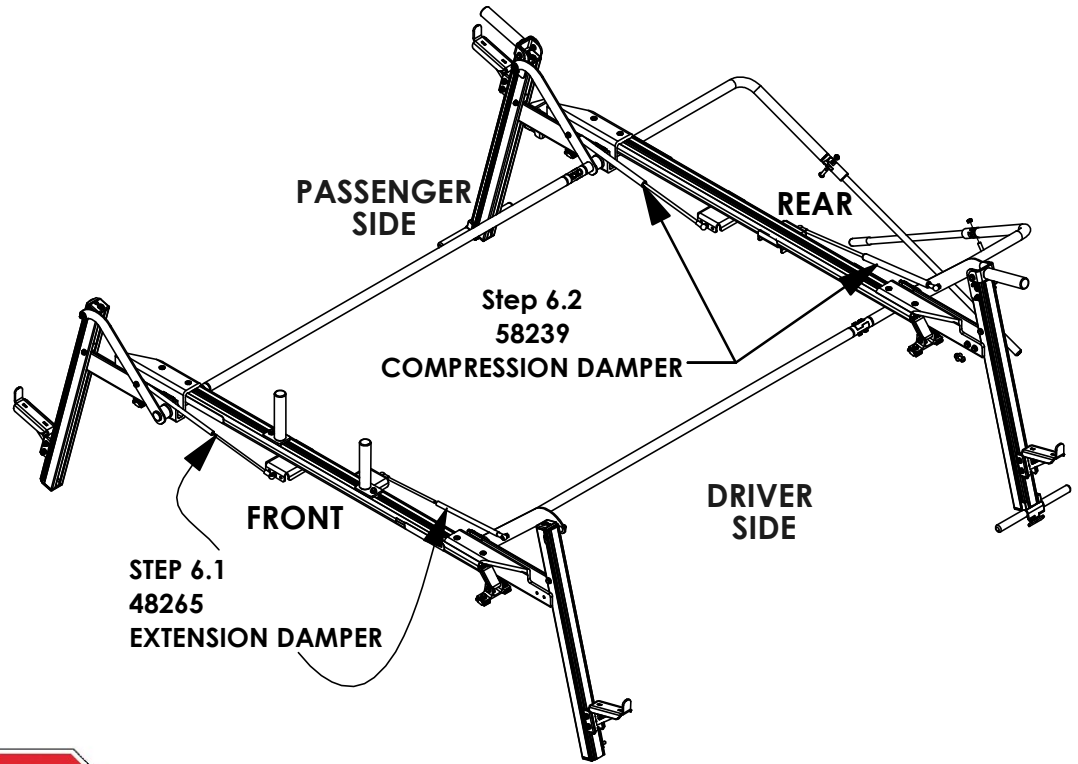

## ORIENTATION OF DAMPER MATTERS!!!!

LARGE CYLINDER OF DAMPER ATTACHES TO ARM  
 SMALL ROD END ATTACHES TO DAMPER BRACKET

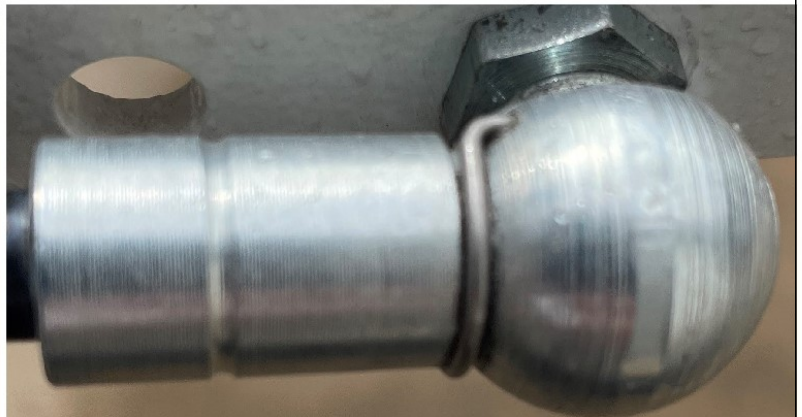
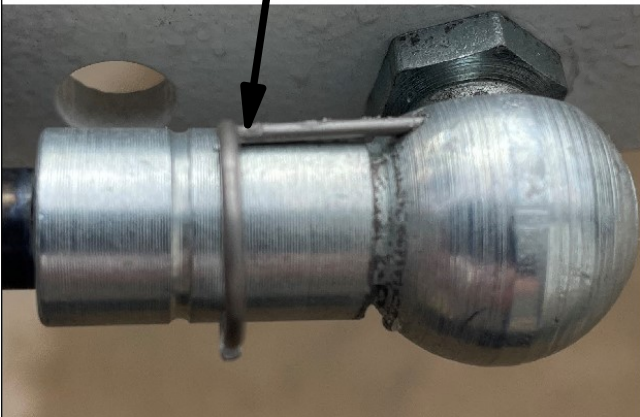
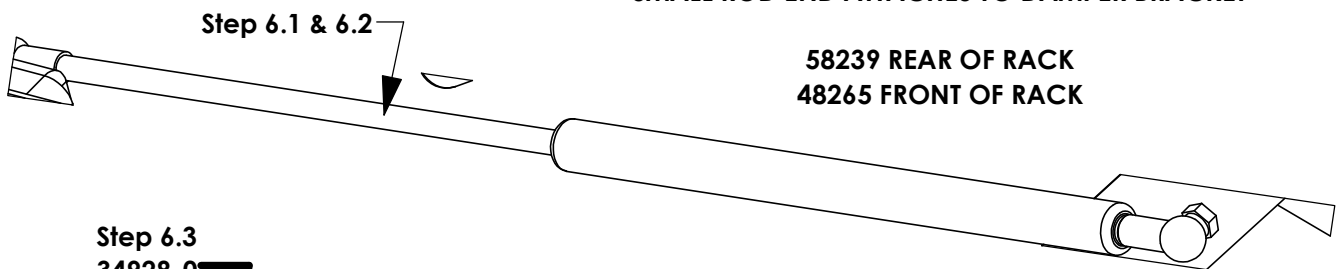

# STEP 7 - WHILE RACK DEPLOYED INSTALL O.S. BAR

Step 7.1  
**FULLY TIGHTEN**  
FAS0861  
(04 PLACES PER  
SIDE)  
1/2" SOCKET

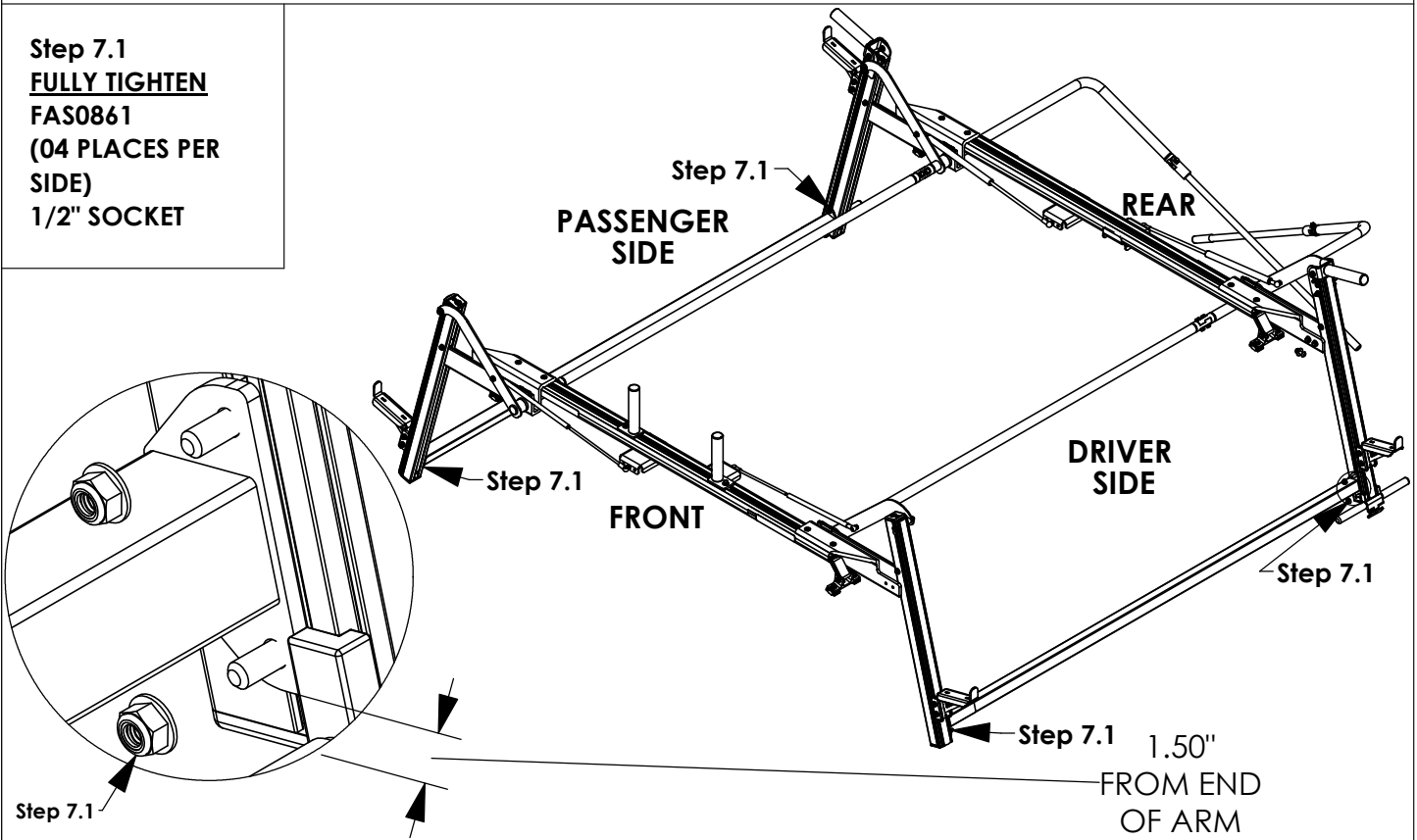

# STEP 8 - INSTALL DROP DOWN HANDLE

Step 8.1  
**FULLY TIGHTEN**  
FAS0819 & FAS0399  
(01 PLACES PER  
SIDE)  
7/32" ALLEN  
9/16" SOCKET

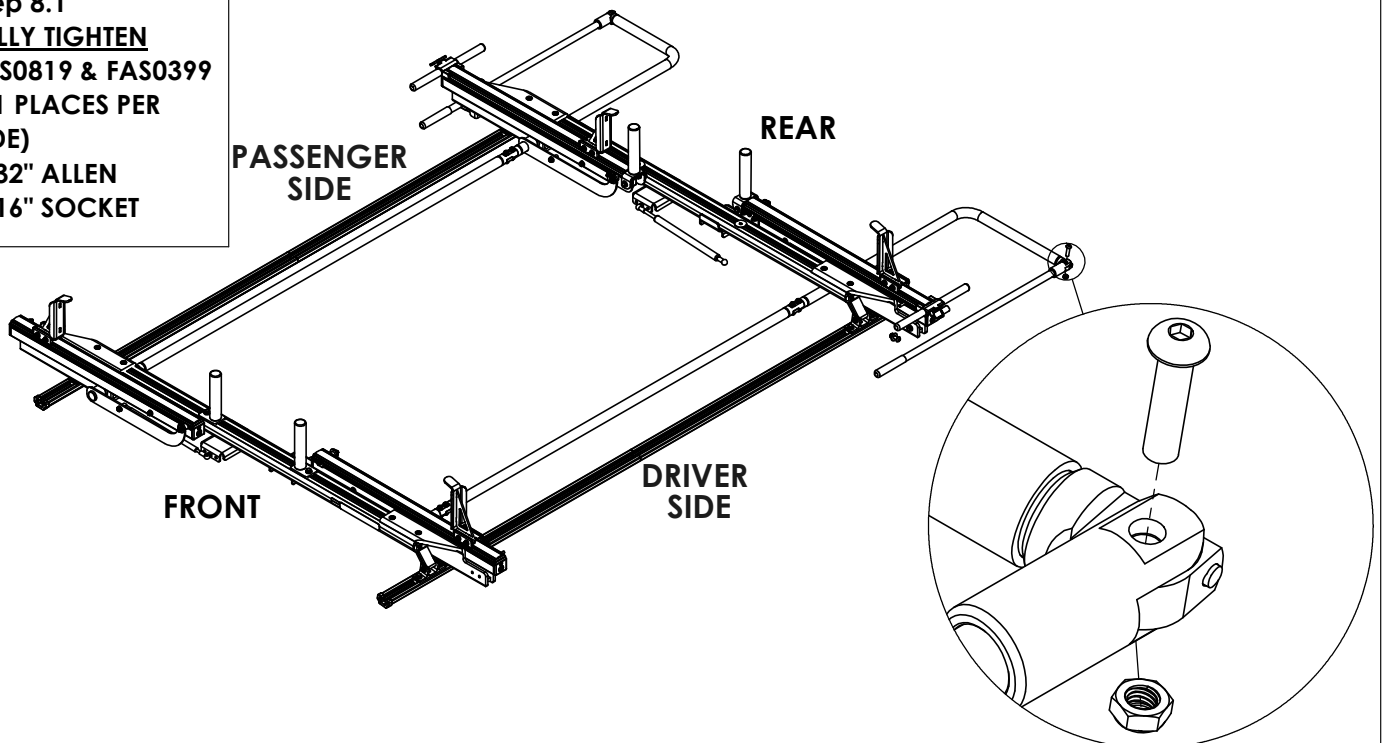



# STEP 9 - INSTALL CROSSBOW END CAPS

Step 9.1  
**FULLY TIGHTEN**  
(02) FAS0473, 65961  
(02 PLACES PER SIDE)  
3/8" SOCKET

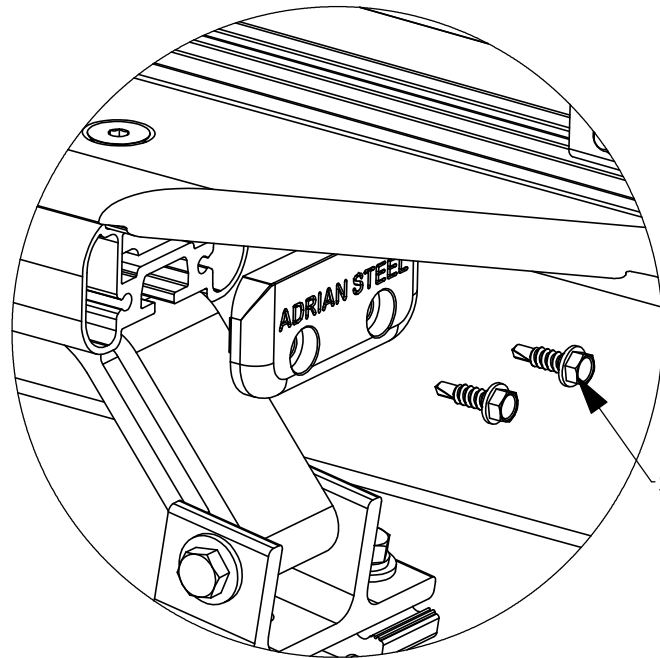

Step 9.1

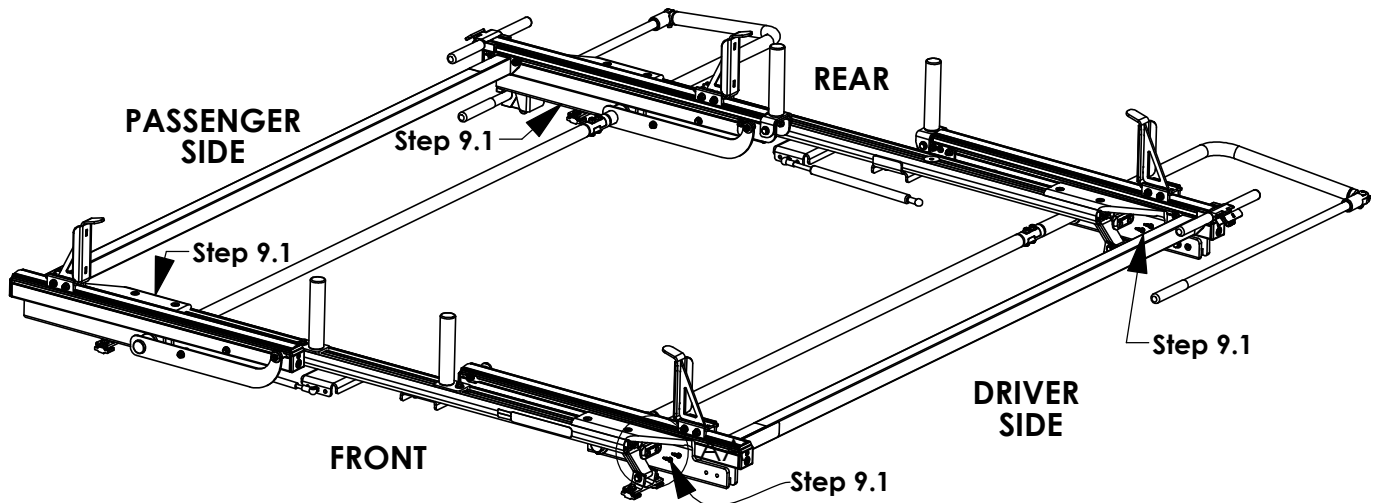

PASSENGER  
SIDE

REAR

Step 9.1

Step 9.1

Step 9.1

DRIVER  
SIDE

FRONT

Step 9.1

# STEP 10 - INSTALL HANDLE LATCH

STEP 10.1  
FULLY TIGHTEN  
FAS0819, FAS0399,  
(01 PLACE)  
7/32" ALLEN  
9/16" SOCKET

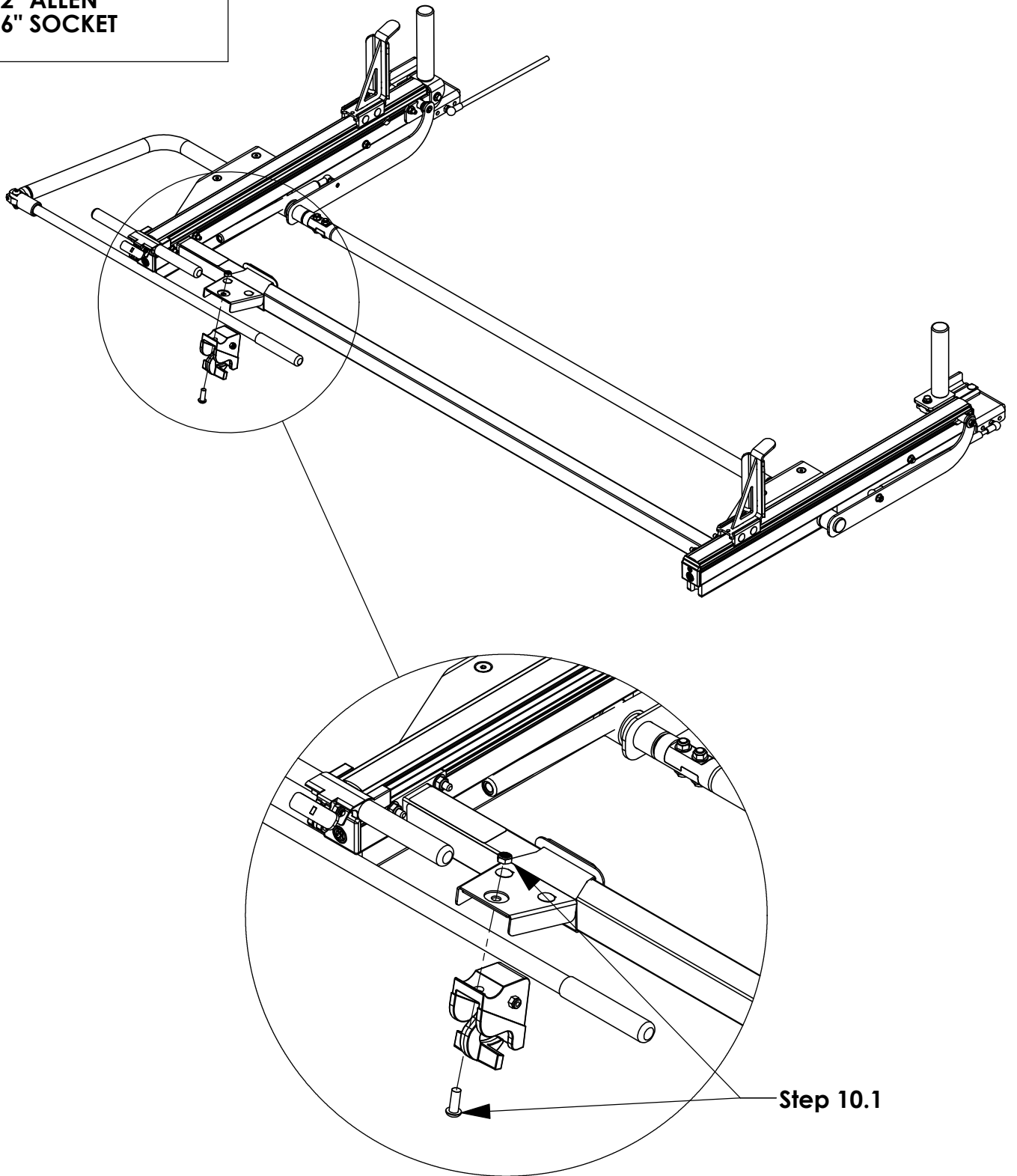

**MAKE SURE ALL FASTENERS ARE TIGHTENED!!! INSTALLATION IS COMPLETE**