

INSTR. NUMBER : 68499	PG: 1	REV: A	ITEM NO.	PART NUMBER	DESCRIPTION	QTY.	
	PART NUMBER : PLMDPSM & PLMDDSM			1	68190-W	MAX DROP ARM ASM,MR,DS, WHITE	1
				2	68013-W	DROP DOWN FRONT ARM ASM DS, WHITE	1
PART DESC. : PROLIFT,MAX,PS,MR & PROLIFT,MAX,DS,MR			3	48265	DAMPER ASSEMBLY	1	
			4	66959-W	DROP DOWN OUTER BAR, WELDMENT, WHITE	1	
			5	58239	COMPRESSION DAMPER	1	
			6	51989	HANDLE ASM, NO PAINT	1	
			7	66563-B	DROP DOWN, SS CENTER DRIVELINE, BLK	1	
			8	68037-B	CLAMP PAD, 6.5", BLACK	2	
			9	68186-W	PROLIFT INNER POST, WHITE	1	
			10	68196-W	PROLIFT MAX DROP STOP, WHITE	1	
			11	68045-W	PROLIFT DAMPER MOUNT, WHITE	2	

PLMDDSMW

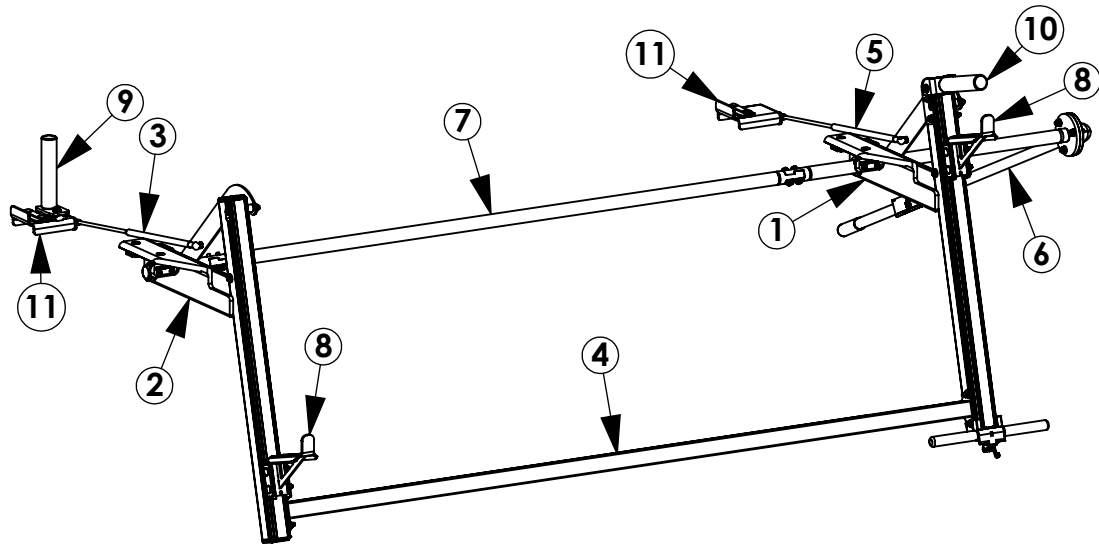

ITEM NO.	PART NUMBER	DESCRIPTION	QTY.
1	68189-W	MAX DROP ARM ASM,MR,PS,WHITE	1
2	68031-W	DROP DOWN FRONT ARM ASSM PS, WHITE	1
3	48265	DAMPER ASSEMBLY	1
4	66959-W	DROP DOWN OUTER BAR, WELDMENT, WHITE	1
5	68037-B	CLAMP PAD, 6.5", BLACK	2
6	58239	COMPRESSION DAMPER	1
7	68186-W	PROLIFT INNER POST, WHITE	1
8	68045-W	PROLIFT DAMPER MOUNT, WHITE	2
9	66572-B	DROP DOWN, CS CENTER DRIVELINE, BLK	1
10	51989	HANDLE ASM, NO PAINT	1
11	68196-W	PROLIFT MAX DROP STOP, WHITE	1

PLMDPSMW

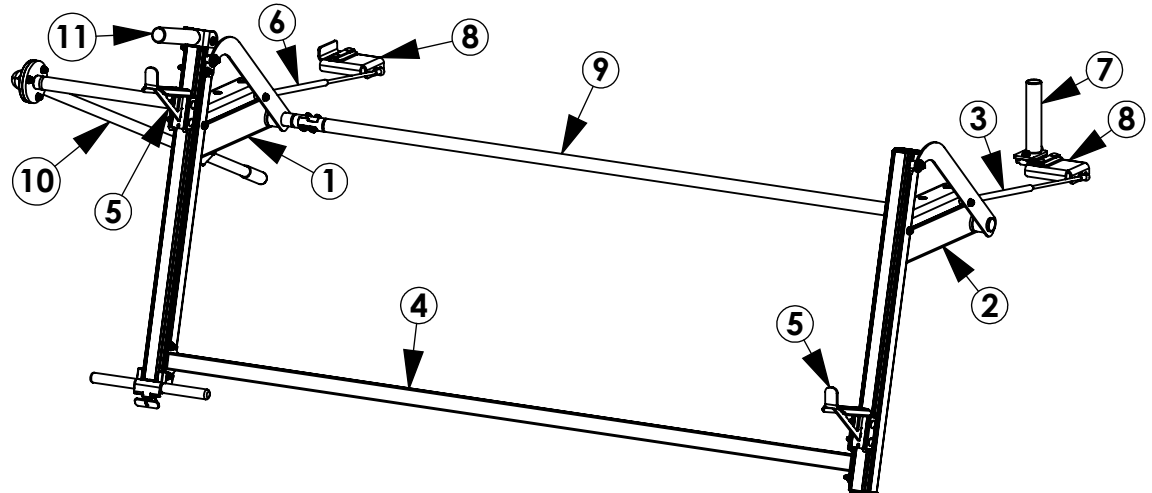

GET TO KNOW THE VEHICLE - AT THE BEGINNING OF ANY INSTALLATION, CHECK THE LOCATION OF THE FUEL TANK, FUEL LINES, BRAKE LINES, HIGH VOLTAGE BATTERIES AND WIRING HARNESSSES TO AVOID INJURY OR PROPERTY DAMAGE FROM TOOL CONTACT.

SEAL ALL EXTERIOR HOLES - ALL INSTALLATION HOLES SHOULD BE SEALED WITH BUTYL TAPE OR SILICON TO PREVENT WATER AND EXHAUST GASES FROM ENTERING THE VEHICLE.

CONTROL DRILL DEPTH - TO AVOID DAMAGE TO THE VEHICLE, USE A DRILL STOP OR CLEARED STEP BIT WHEN DRILLING INSTALLATION HOLES.

ALWAYS ADD PRIMER - WHEN ADDING INSTALLATION HOLES BE SURE TO USE A SELF-ETCHING PRIMER TO PREVENT CORROSION, FASTENER FAILURE AND INJURY.

MOUNTING POINTS MUST HAVE METAL-TO-METAL CONTACT - USE PROVIDED MOUNTING SPACERS TO ACCOMMODATE FOR VEHICLE FEATURES, CARPET OR SUBFLOORS.

PROVIDE CLEARANCE FOR SPACERS - IF THE INSTALLATION VEHICLE CONTAINS A CARPET OR SUBFLOOR, USE A 1-3/16" DIAMETER CARPET CUTTER (P/N: 31183-0) AT ALL MOUNTING LOCATIONS TO OPEN UP ROOM FOR SPACERS.

CHECK SPACER ORIENTATION - BE SURE THAT THE INDENT IN THE SPACER COVERS THE PLUSNUT HEAD; THIS ENSURES THE MOST METAL-TO-METAL CONTACT AND REDUCES VIBRATION.

PLUSNUT INSTALLATION - A PLUSNUT GUN IS RECOMMENDED FOR PLUSNUT INSTALLATION FOR ITS PRODUCTION SPEED. HOWEVER, A PLUSNUT SETTING TOOL CAN ALSO BE USED (P/N: 22200-0).

THRU-BOLT CLEARANCE - WHEN USING A THRU-BOLT AT ANY MOUNTING LOCATION, BE SURE THAT YOUR HOLE HAS 1/16" CLEARANCE.

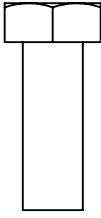
FASTENERS AND HARDWARE USED

FAS0283
SCREW,HH
5/16-18X.875
QTY: 3

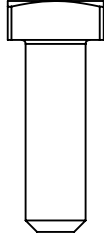

FAS0035
BOLT,SQ HD
5/16-18X1.0
QTY: 2

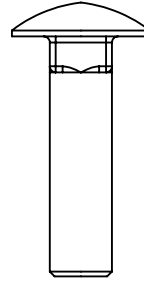

FAS0812
BOLT,CRG
5/16-18X1.25
QTY: 4

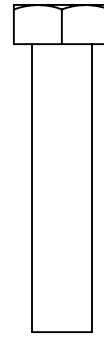

FAS0242
SCREW,HH
5/16-18X1.5
QTY: 4

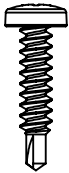

FAS0782
SCREW,THP TEK
#8X.75
QTY: 3

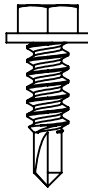

FAS0473
SCREW,HH TEK
#12X.75
QTY: 4

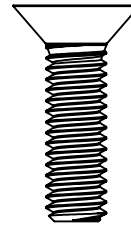

FAS0856
SCREW,FHH
5/16-18X1.13
QTY: 4

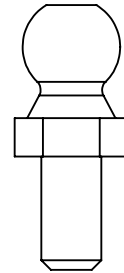

34927-0
BALL STUD
13MM X 5/16-18
QTY: 2

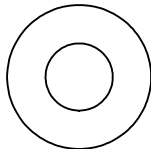

FAS0552
WASHER,FLAT
USS 5/16
QTY: 7



FAS0588
WASHER,LCK
SPLIT 5/16
QTY: 1

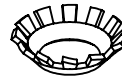

FAS0857
WASHER,LCK EXT
CS 5/16
QTY: 04

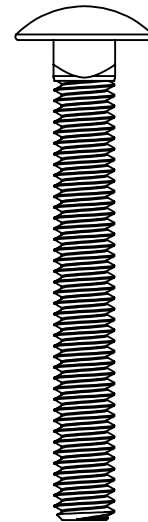

FAS0838
BOLT,CRG
5/16-18X2.5
QTY: 04

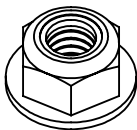

FAS0861
NUT,HEX NLK
FLG 5/16-18
QTY: 20



34928-0
CLIP,SPRING,
RETAINER,13MM
QTY: 4

FASTENERS AND HARDWARE USED

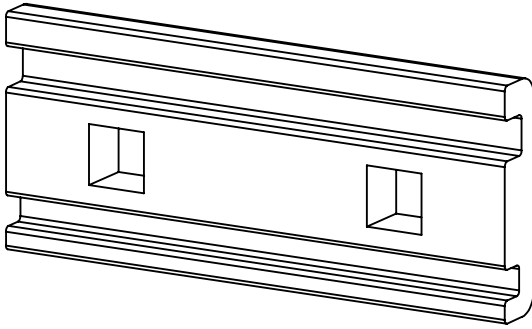

65963
REAR ROLLER, SPACER
QTY: 4

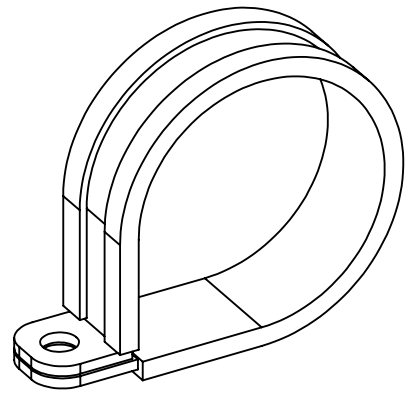

34921-0
CLAMP, CABLE 1-1/2"
QTY: 1

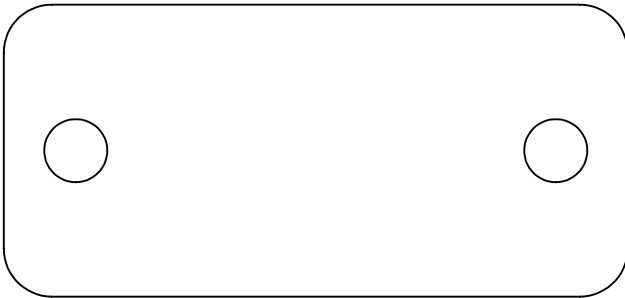

64831
REAR ROLLER, SPACER
QTY: 02

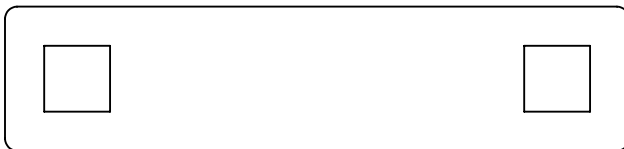

64830
REAR ROLLER, BOLT PLATE
QTY: 2

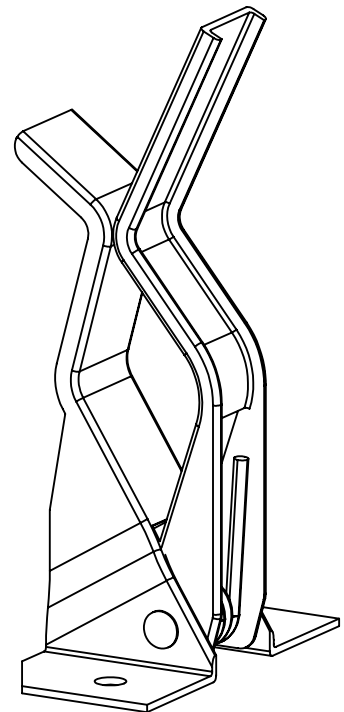

34922-0
HOLDER, TOOL
QTY: 1

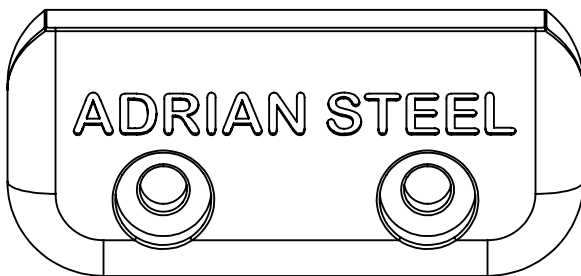

65961
DROP DOWN END CAP
QTY: 2

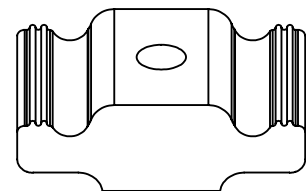

63490
RAIL SLIDE, 1"
QTY: 5

BEGIN ASSEMBLY

STEP 1 - INSTALL CLAMPS AND HARDWARE ON DROP DOWN CARTRIDGES

PASSENGER SIDE CARTRIDGES

FRONT SUB-ASSEMBLY

REAR SUB-ASSEMBLY

USE FAS0283,
FAS0552, & FAS0861
(2 PLACES)
1/2" WRENCH
1/2" SOCKET

USE FAS0838 & FAS0861
(4 PLACES)
1/2" SOCKET

LOOSELY INSTALL
FAS0856, FAS0857, &
63490
(4 PLACES)

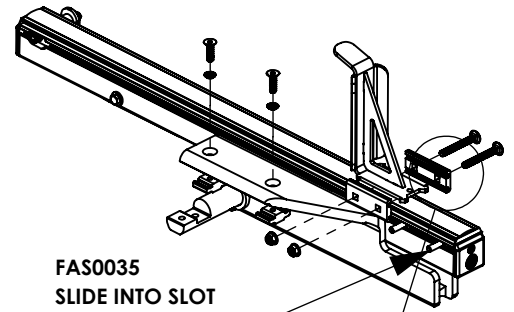

FAS0035
SLIDE INTO SLOT
(02 PLACES)

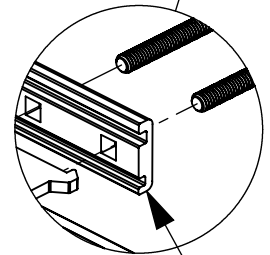

**NOTE ORIENTATION:
SMALLER CHANNEL
ON BOTTOM**

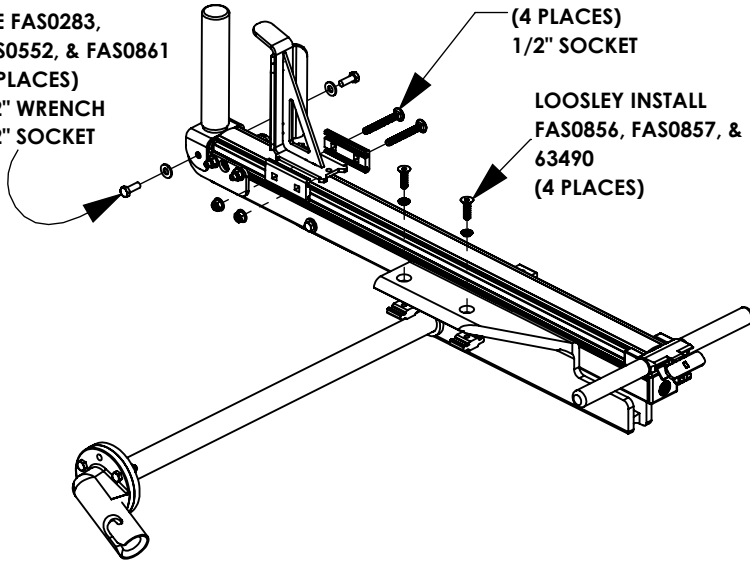

REAR SUB-ASSEMBLY

**DRIVER SIDE
CARTRIDGES**

USE FAS0283,
FAS0552, & FAS0861
(2 PLACES)
1/2" WRENCH
1/2" SOCKET

LOOSELY INSTALL
FAS0856, FAS0857, &
63490
(4 PLACES)

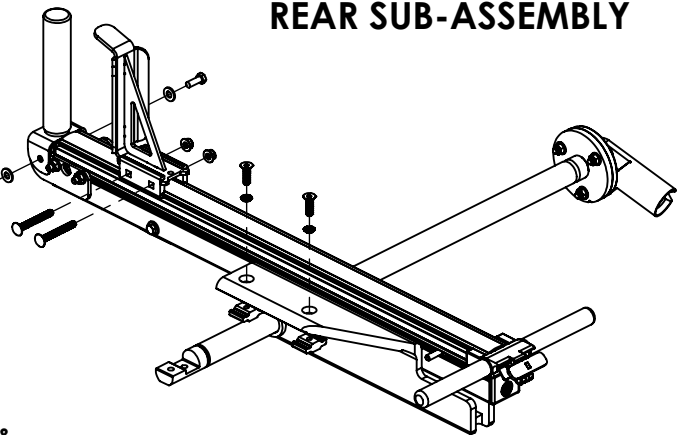

FRONT SUB-ASSEMBLY

USE FAS0838 & FAS0861
(4 PLACES)
1/2" SOCKET

FAS0035
SLIDE INTO SLOT
(2 PLACES)

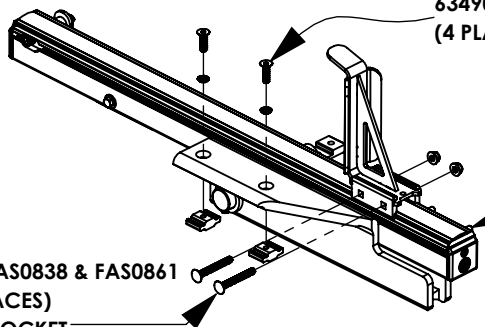

STEP 2 - MOUNT DAMPER BRACKETS AND INNER STOPS TO CROSSBOWS

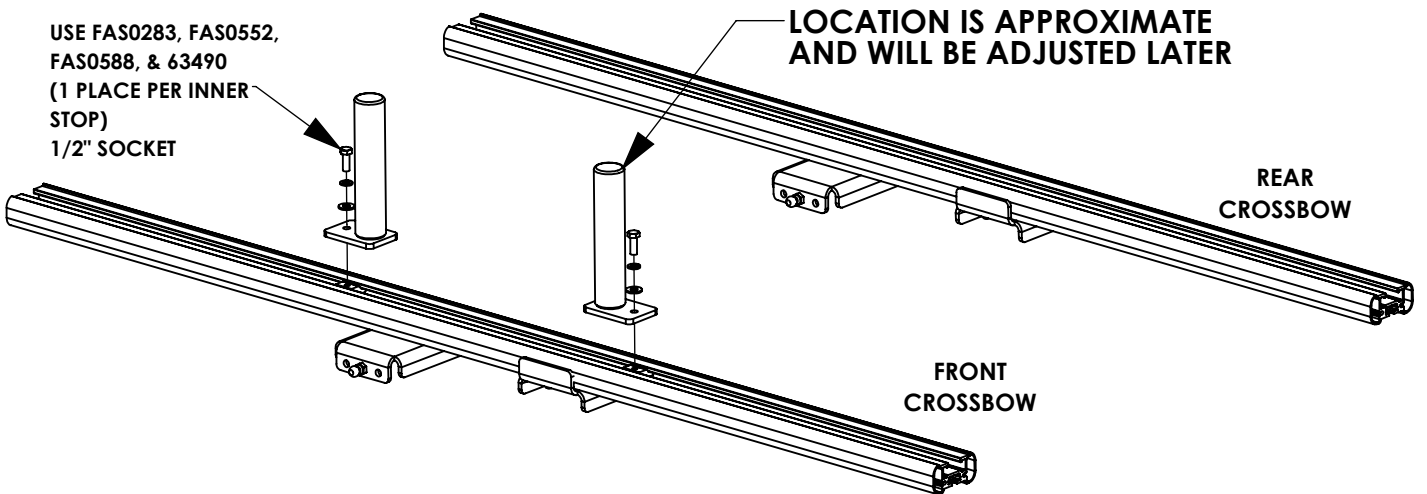
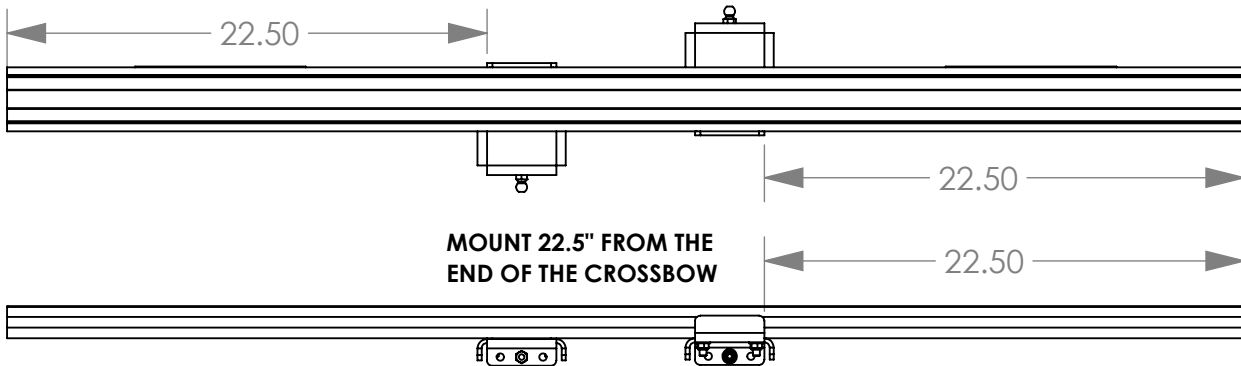
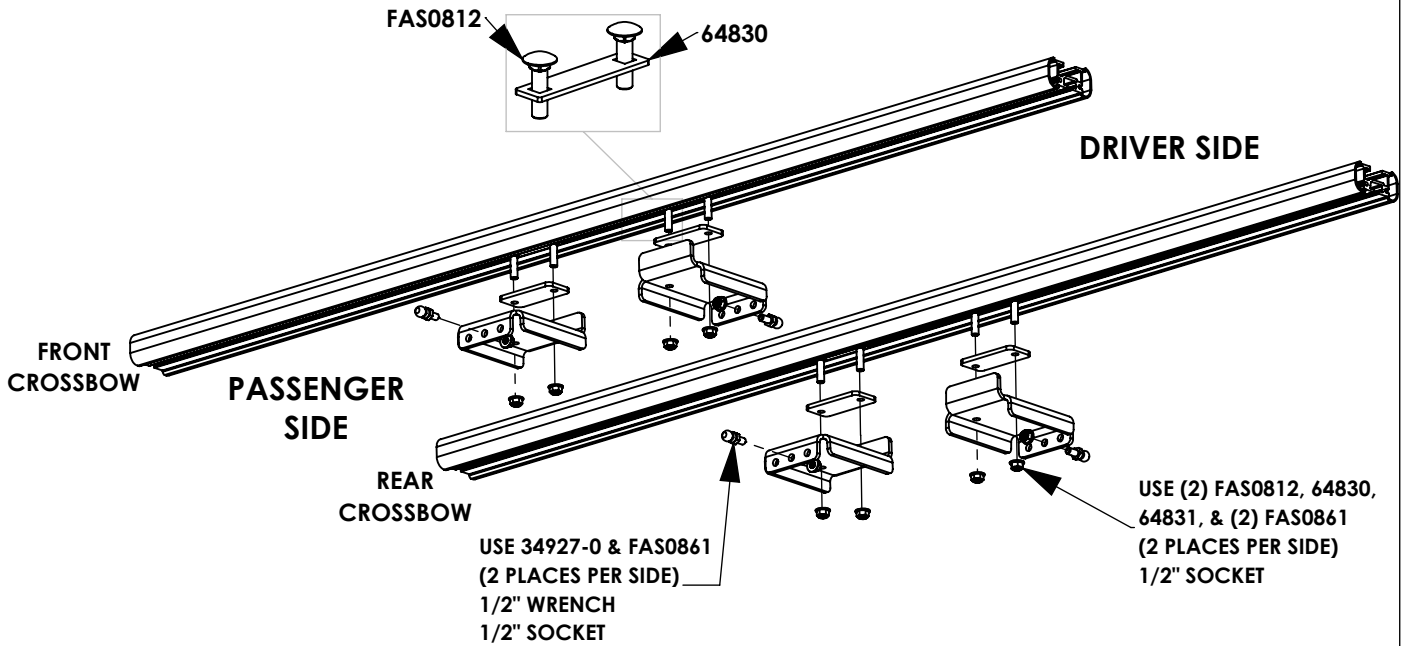

STEP 3 - INSTALL CARTRIDGES ON CROSSBOWS

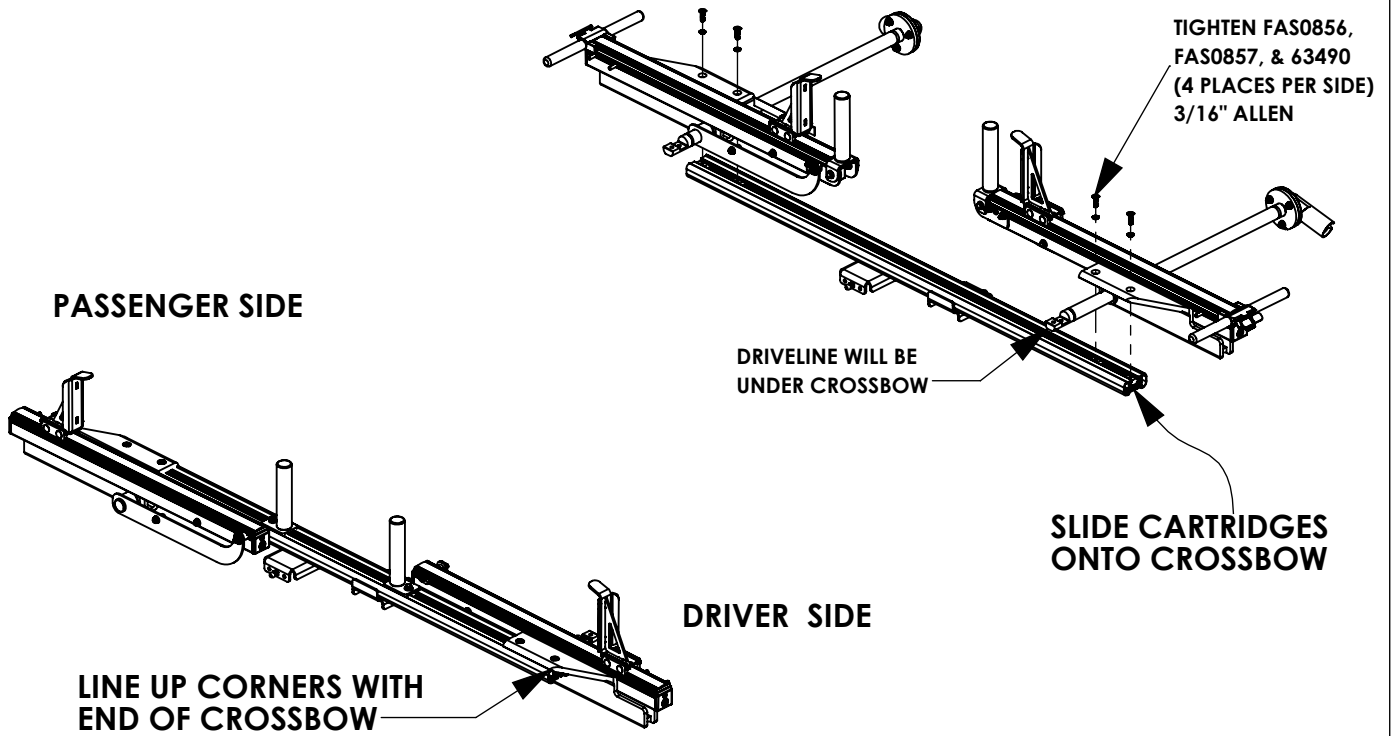

STEP 4 - INSTALL DAMPERS

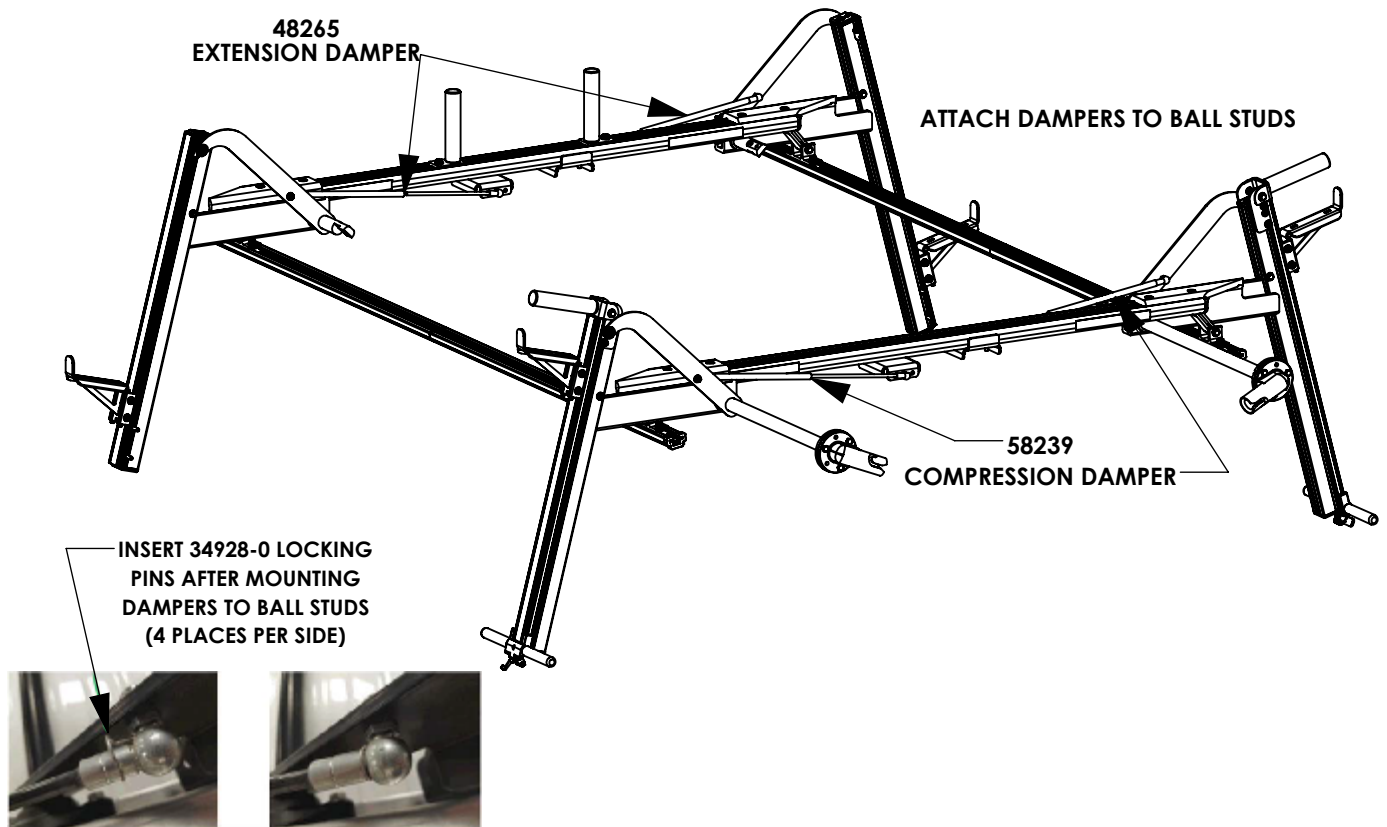

STEP 5 - INSTALL O.S. BAR AND THEN THE DRIVELINE

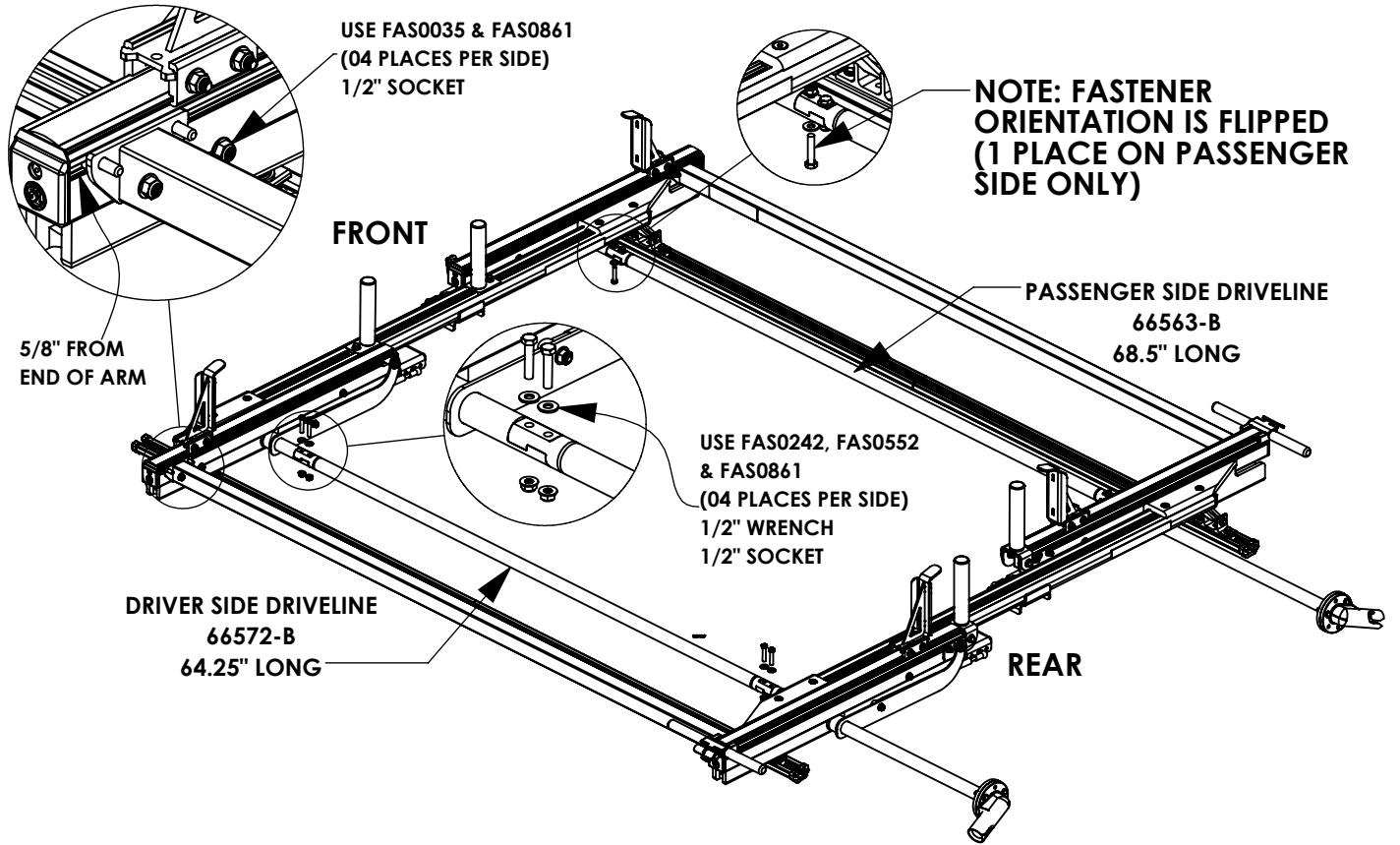

STEP 6 - INSTALL CROSSBOW END CAPS

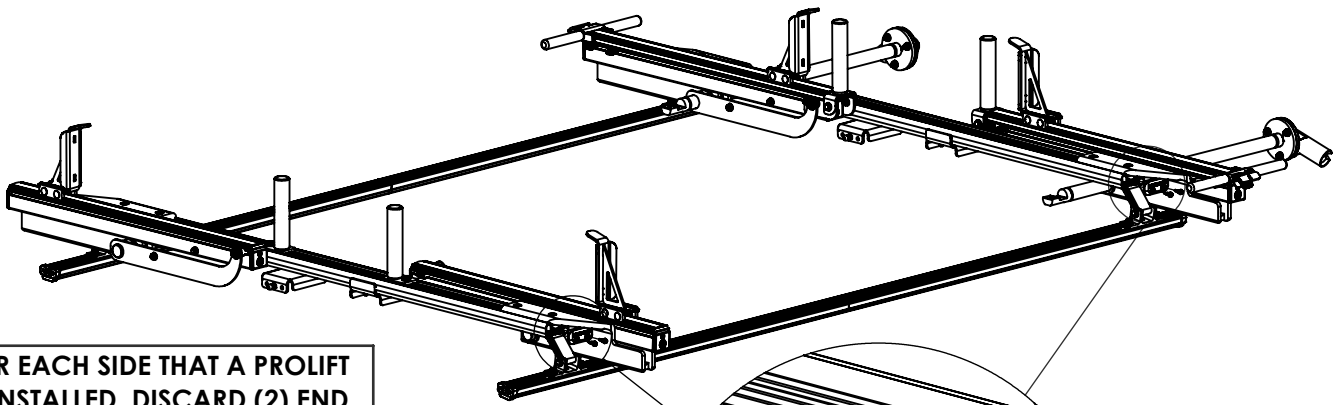

FOR EACH SIDE THAT A PROLIFT IS INSTALLED, DISCARD (2) END CAPS THAT ARE INCLUDED WITH THE CROSSBOW KIT.

SHOWN BELOW:

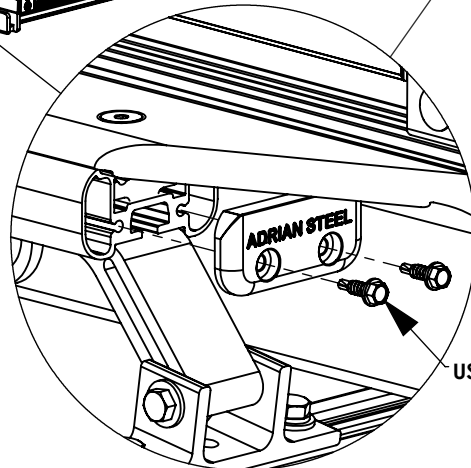

USE 65961 & (2) FAS0473
(2 PLACES PER SIDE)
3/8" SOCKET

STEP 7 - INSTALL HANDLE STORAGE HARDWARE

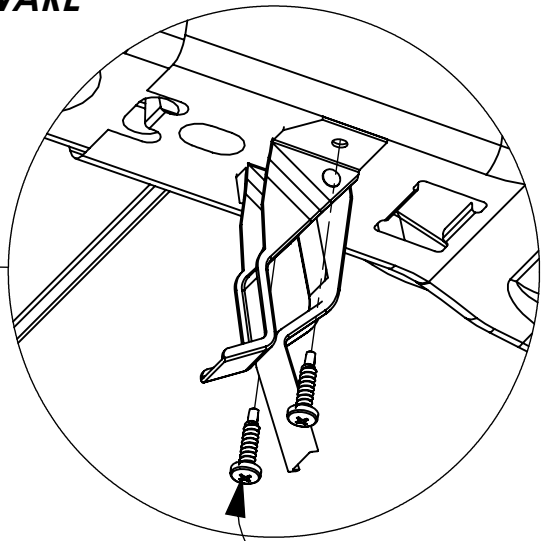
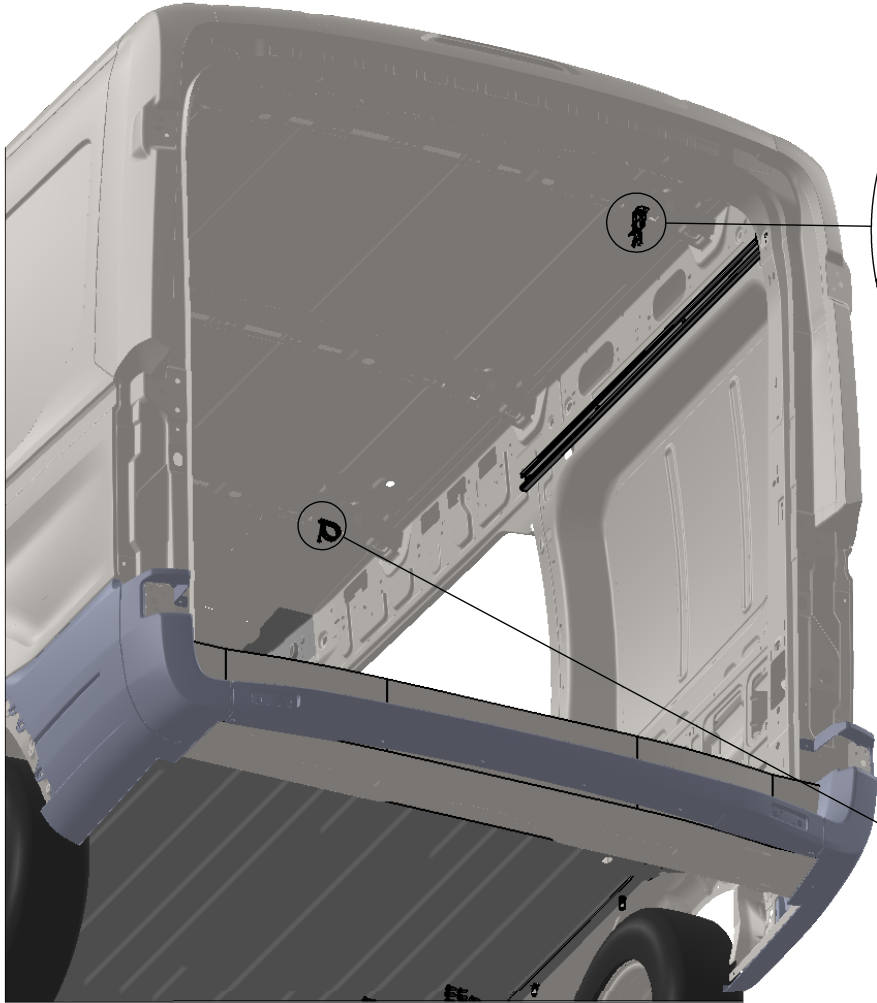

USE FAS0782
(03 PLACES)
#2 PHILLIPS

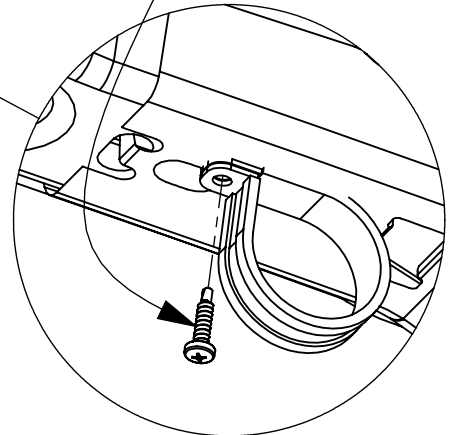

STEP 8 - CLIP HANDLE INTO STORAGE CLIP

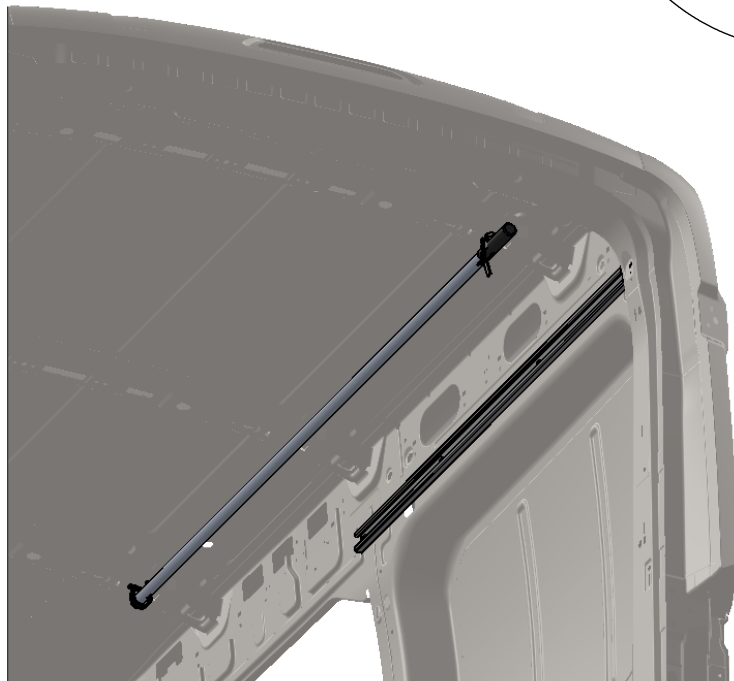



Mounting Roof Rail Kit, Transit

PRODUCT WEIGHT
7.2 LBS

HEIGHT OFF ROOF
SEE TABLE BELOW



CAPACITY
**REFER TO OEM'S
RECOMMENDED LOAD
RATING**
COLOR

RAW

CATALOG NUMBER

RRKFT

PRODUCT FEATURES

Ford Transit aluminum mounting roof rail kit for the PROFILE™ HD Utility, Grip-Lock, ProLift, and combo ladder racks. Mounting kit works on all roof height and wheelbase combinations for Ford Transit vans.

Utility and Grip-Lock racks are not recommended for medium or high roof vehicles!

SEE PAGES 2 & 3 FOR APPLICATION NOTES AND ACCESSORIES, OTHER PRODUCTS THAT WORK WITH THIS UNIT.

PAGE 1 of 4

The information contained in this document is the sole property of ADRIAN STEEL COMPANY. ADRIAN STEEL COMPANY retains the right to modify and/or change the product of its design at any time without prior notification.



CATALOG NUMBER RRKFT

PRODUCT APPLICATION

This product is designed to be installed Ford Transit vans. HD Utility and Grip-Lock racks are not recommended for medium or high roof vehicles!

ACCESSORIES THAT WILL WORK WITH THIS PRODUCT

CATALOG NUMBER	DESCRIPTION	CATALOG NUMBER	DESCRIPTION
White Kit Part Numbers		Black Kit Part Numbers	
Crossbow Kits			
2BARW	2-Crossbar Kit, 68", White, Full Size Van	2BARB	2-Crossbar Kit, 68", Black, Full Size Van
1BARW	2-Crossbar Kit, 48", White, Full Size Van	1BARB	2-Crossbar Kit, 48", Black, Full Size Van
2BARCW	2-Crossbar Kit, 48", White, Minivan	2BARCB	2-Crossbar Kit, 48", Black, Minivan
1BARCW	Single Crossbar Kit, 48", White, Minivan	1BARCB	Single Crossbar Kit, 48", Black, Minivan
Mounting Bracket Kits			
URMBK4W	Mounting Bracket Kit, 4-Pack, White, Multiple Vehicles	URMBK4B	Mounting Bracket Kit, 4-Pack, Black, Multiple Vehicles
URMBK2W	Mounting Bracket Kit, 2-Pack, White, Multiple Vehicles	URMBK2B	Mounting Bracket Kit, 2-Pack, Black, Multiple Vehicles
Ladder Stop & Upright Kits			
ULSKB	Single Ladder Stop Kit, Black	ULSKAB	Single Ladder Stop Kit, Black
4UPK4B	4" Upright Kit, 4-Pack, Black	4UPK4AB	4" Upright Kit, 4-Pack, Black
4UPK2B	4" Upright Kit, 2-Pack, Black	4UPK2AB	4" Upright Kit, 2-Pack, Black
6UPK4B	6" Upright Kit, 4-Pack, Black	6UPK4AB	6" Upright Kit, 4-Pack, Black
6UPK2B	6" Upright Kit, 2-Pack, Black	6UPK2AB	6" Upright Kit, 2-Pack, Black
9UPK4B	9" Upright Kit, 4-Pack, Black	9UPK4AB	9" Upright Kit, 4-Pack, Black
9UPK2B	9" Upright Kit, 2-Pack, Black	9UPK2AB	9" Upright Kit, 2-Pack, Black
RSK1B	Single Ratchet Upright Kit, 9", Black	RSK1AB	Single Ratchet Upright Kit, 9", Black

Continued on Page 3



CATALOG NUMBER **RRKFT**

PRODUCT APPLICATION

This product is designed to be installed Ford Transit vans. HD Utility and Grip-Lock racks are not recommended for medium or high roof vehicles!

ACCESSORIES THAT WILL WORK WITH THIS PRODUCT

CATALOG NUMBER	DESCRIPTION	CATALOG NUMBER	DESCRIPTION
White Kit Part Numbers		Black Kit Part Numbers	
Grip-Lock Kits			
GL-FSVDS	Driver Side Grip-Lock Kit, Full Size Van	GL-FSVDS-B	Driver Side Grip-Lock Kit, Full Size Van, Black
GL-FSVPS	Passenger Side Grip-Lock Kit, Full Size Van	GL-FSVPS-B	Passenger Side Grip-Lock Kit, Full Size Van, Black
Standard Drop ProLift Kits			
SDPLDS	Driver Side Standard Drop ProLift Kit, Full Size Van	SDPLDS-B	Driver Side Standard Drop ProLift Kit, Full Size Van, Black
SDPLPS	Passenger Side Standard Drop ProLift Kit, Full Size Van	SDPLPS-B	Passenger Side Standard Drop ProLift Kit, Full Size Van, Black
Max Drop ProLift Kits			
DDPLDS	Driver Side Max Drop ProLift Kit, Full Size Van	DDPLDS-B	Driver Side Max Drop ProLift Kit, Full Size Van, Black
DDPLPS	Passenger Side Max Drop ProLift Kit, Full Size Van	DDPLPS-B	Passenger Side Max Drop ProLift Kit, Full Size Van, Black
DDPLDSM	Driver Side Max Drop ProLift Kit, Full Size Van, Mid Roof	DDPLDSM-B	Driver Side Max Drop ProLift Kit, Full Size Van, Mid Roof, Black
DDPLPSM	Passenger Side Max Drop ProLift Kit, Full Size Van, Mid Roof	DDPLPSM-B	Passenger Side Max Drop ProLift Kit, Full Size Van, Mid Roof, Black
DDPLDSH	Driver Side Max Drop ProLift Kit, Full Size Van, High Roof	DDPLDSH-B	Driver Side Max Drop ProLift Kit, Full Size Van, High Roof, Black
DDPLPSH	Passenger Side Max Drop ProLift Kit, Full Size Van, High Roof	DDPLPSH-B	Passenger Side Max Drop ProLift Kit, Full Size Van, High Roof, Black
Double Stack ProLift Kits			
DSPLDS	Driver Side Double Stack ProLift Kit, Full Size Van	DSPLDS-B	Driver Side Double Stack ProLift Kit, Full Size Van, Black
DSPLPS	Passenger Side Double Stack ProLift Kit, Full Size Van	DSPLPS-B	Passenger Side Double Stack ProLift Kit, Full Size Van, Black



CATALOG NUMBER RRKFT

PRODUCT APPLICATION

This product is designed to be installed Ford Transit vans. HD Utility and Grip-Lock racks are not recommended for medium or high roof vehicles!

LADDER RACK HEIGHTS MEASURED FROM ROOF OF VEHICLE

CONFIGURATION	RACK HEIGHT LOW / MED / HIGH ROOF
Base Rack	5.5" / 4.6" / 4.6"
Base + Ladder Stop	11.0" / 10.1" / 10.1"
Base + 4" Uprights	9.0" / 8.1" / 8.1"
Base + 6" Uprights	11.0" / 10.1" / 10.1"
Base + 9"/Ratchet Uprights	14.0" / 13.1" / 13.1"
Base + 4" PVC Conduit Kit	9.9" / 9.0" / 9.0"
Base + 6" PVC Conduit Kit	11.9" / 11.0" / 11.0"
Base + Aluminum Box Conduit Kit	12.0" / 11.2" / 11.2"
Base + Grip-Lock	12.2" / (N/A) / (N/A)
Base + Standard Drop ProLift	12.5" / (N/A) / (N/A)
Base + Max Drop ProLift	14.0" / 13.1" / 13.1"
Base + Double Stack ProLift	Coming Soon!

INSTR. NUMBER	PG:	REV:	ITEM NO.	PART NUMBER	DESCRIPTION	QTY.
67267	1	A	1	63477	ROOF RAIL, FORD TRNST FSV	4
PART NUMBER : RRKFT			2	BAGRRTM	Fas Bag, Transit Roof Rail Kit	1
PART DESC. : ROOF RAIL KIT FT FSV			3	BAG63411	BAG FOR ROOF RAIL CONNECTOR	1
			4	63390	FOAM TAPE 1/4X2X120'TB	4
			5	66424	PLASTIC SLEEVE FOR ROOF RAILS	4
			6	47106	GASKET, FOOT, MR TRANS L/R	6

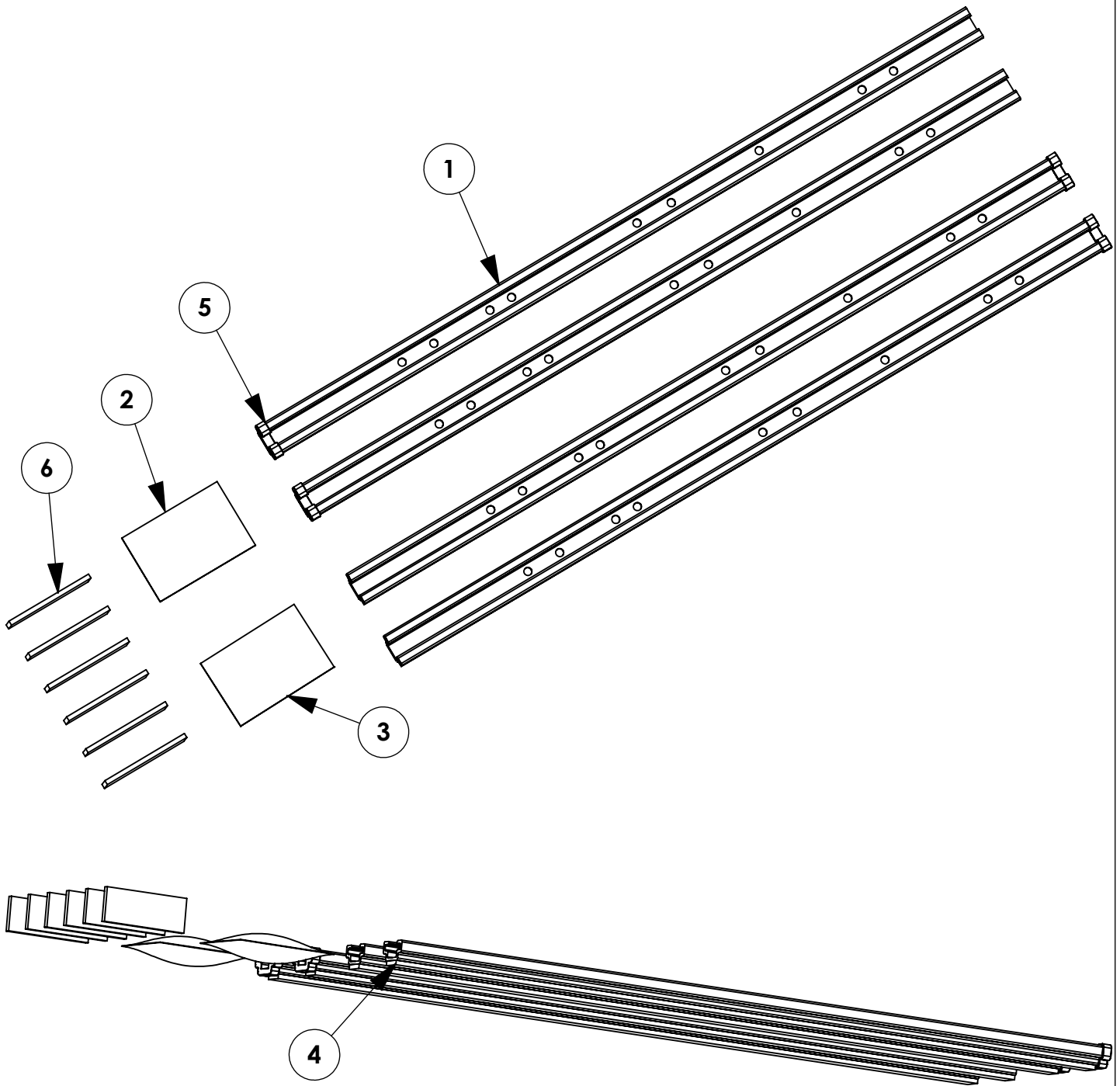

GET TO KNOW THE VEHICLE - AT THE BEGINNING OF ANY INSTALLATION, CHECK THE LOCATION OF THE FUEL TANK, FUEL LINES, BRAKE LINES, HIGH VOLTAGE BATTERIES AND WIRING HARNESSSES TO AVOID INJURY OR PROPERTY DAMAGE FROM TOOL CONTACT.

SEAL ALL EXTERIOR HOLES - ALL INSTALLATION HOLES SHOULD BE SEALED WITH BUTYL TAPE OR SILICON TO PREVENT WATER AND EXHAUST GASES FROM ENTERING THE VEHICLE.

CONTROL DRILL DEPTH - TO AVOID DAMAGE TO THE VEHICLE, USE A DRILL STOP OR CLEARED STEP BIT WHEN DRILLING INSTALLATION HOLES.

ALWAYS ADD PRIMER - WHEN ADDING INSTALLATION HOLES BE SURE TO USE A SELF-ETCHING PRIMER TO PREVENT CORROSION, FASTENER FAILURE AND INJURY.

MOUNTING POINTS MUST HAVE METAL-TO-METAL CONTACT - USE PROVIDED MOUNTING SPACERS TO ACCOMMODATE FOR VEHICLE FEATURES, CARPET OR SUBFLOORS.

PROVIDE CLEARANCE FOR SPACERS - IF THE INSTALLATION VEHICLE CONTAINS A CARPET OR SUBFLOOR, USE A 1-3/16" DIAMETER CARPET CUTTER (P/N: 31183-0) AT ALL MOUNTING LOCATIONS TO OPEN UP ROOM FOR SPACERS.

CHECK SPACER ORIENTATION - BE SURE THAT THE INDENT IN THE SPACER COVERS THE PLUSNUT HEAD; THIS ENSURES THE MOST METAL-TO-METAL CONTACT AND REDUCES VIBRATION.

PLUSNUT INSTALLATION - A PLUSNUT GUN IS RECOMMENDED FOR PLUSNUT INSTALLATION FOR ITS PRODUCTION SPEED. HOWEVER, A PLUSNUT SETTING TOOL CAN ALSO BE USED (P/N: 22200-0).

THRU-BOLT CLEARANCE - WHEN USING A THRU-BOLT AT ANY MOUNTING LOCATION, BE SURE THAT YOUR HOLE HAS 1/16" CLEARANCE.

FASTENERS USED

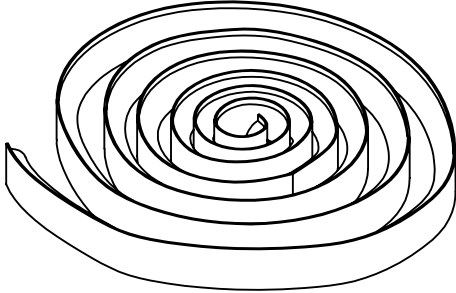

05586-0
BUTYL TAPE
1FT ROLL
QTY: 1

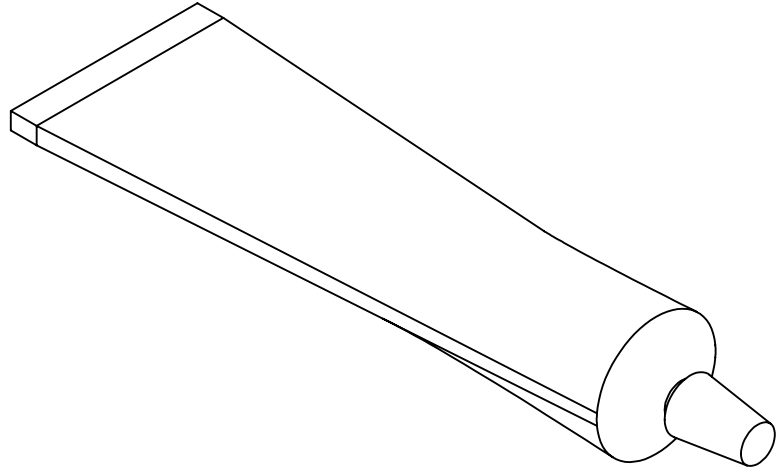

26618-0
SILICONE
1OZ TUBE
QTY: 1

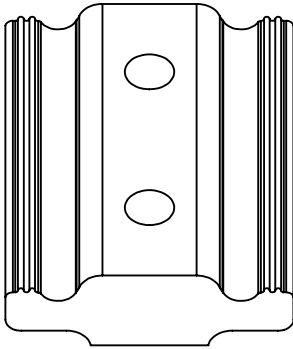

63491
RAIL CONNECTOR, 2"
QTY: 2

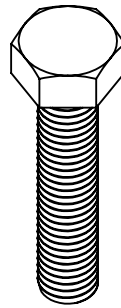

FAS0351
SCREW, HH SS
M8-1.25X40
QTY: 6

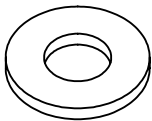

FAS0552
WASHER, FLAT
5/16 SS
QTY: 6



FAS0497
SCREW, SET
5/16-18X.75 SS
QTY: 4



FAS0588
WASHER, LCK
SPLIT 5/16 SS
QTY: 6

ROOF RAIL INSTALL LOCATION - 130 WHEEL BASE

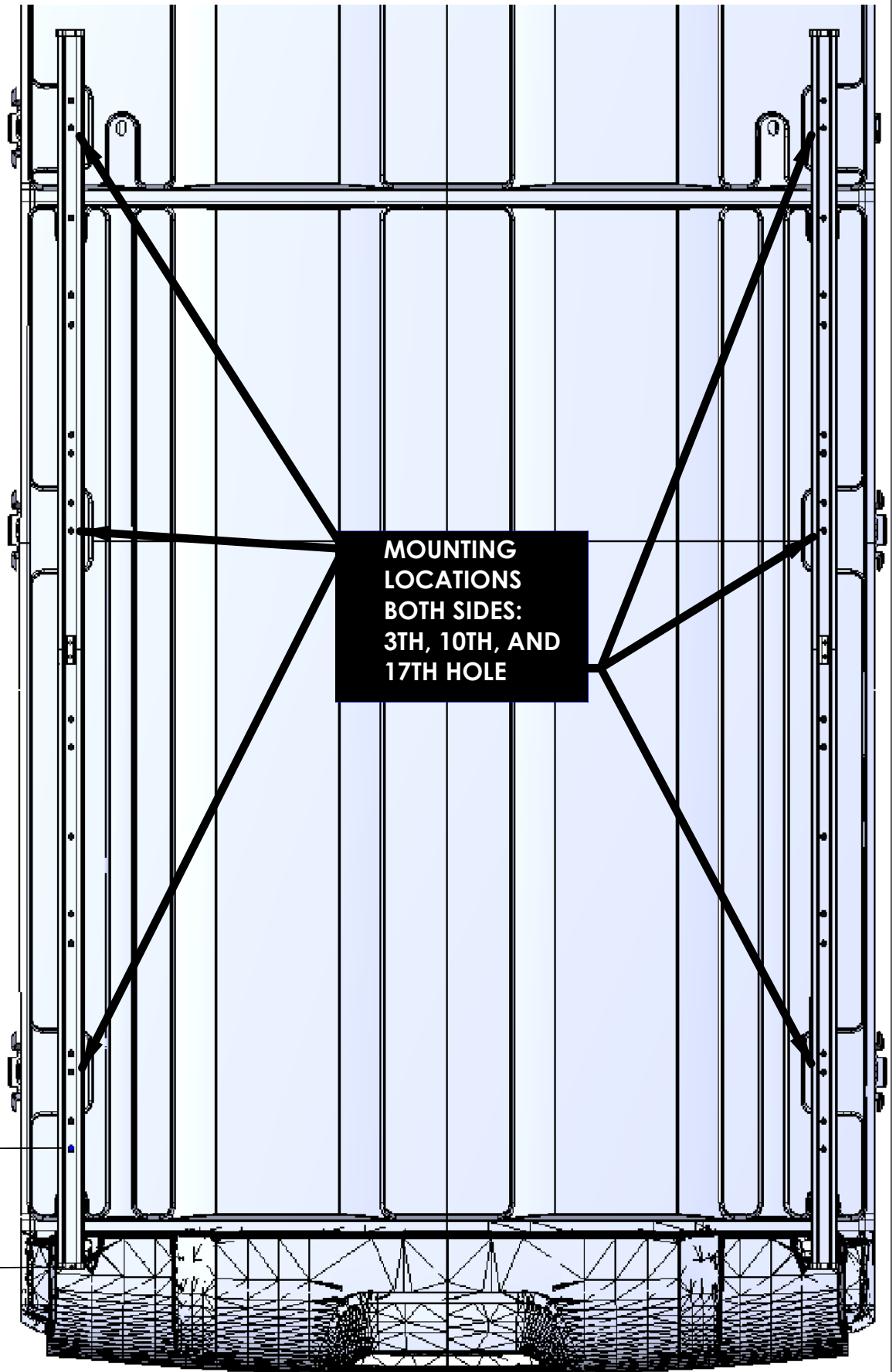

**MOUNTING
LOCATIONS
BOTH SIDES:
3TH, 10TH, AND
17TH HOLE**

8.563" FIRST
HOLE FROM
END OF RAIL

REAR OF VAN

INSTALL ROOF RAILS - 148 WHEEL BASE

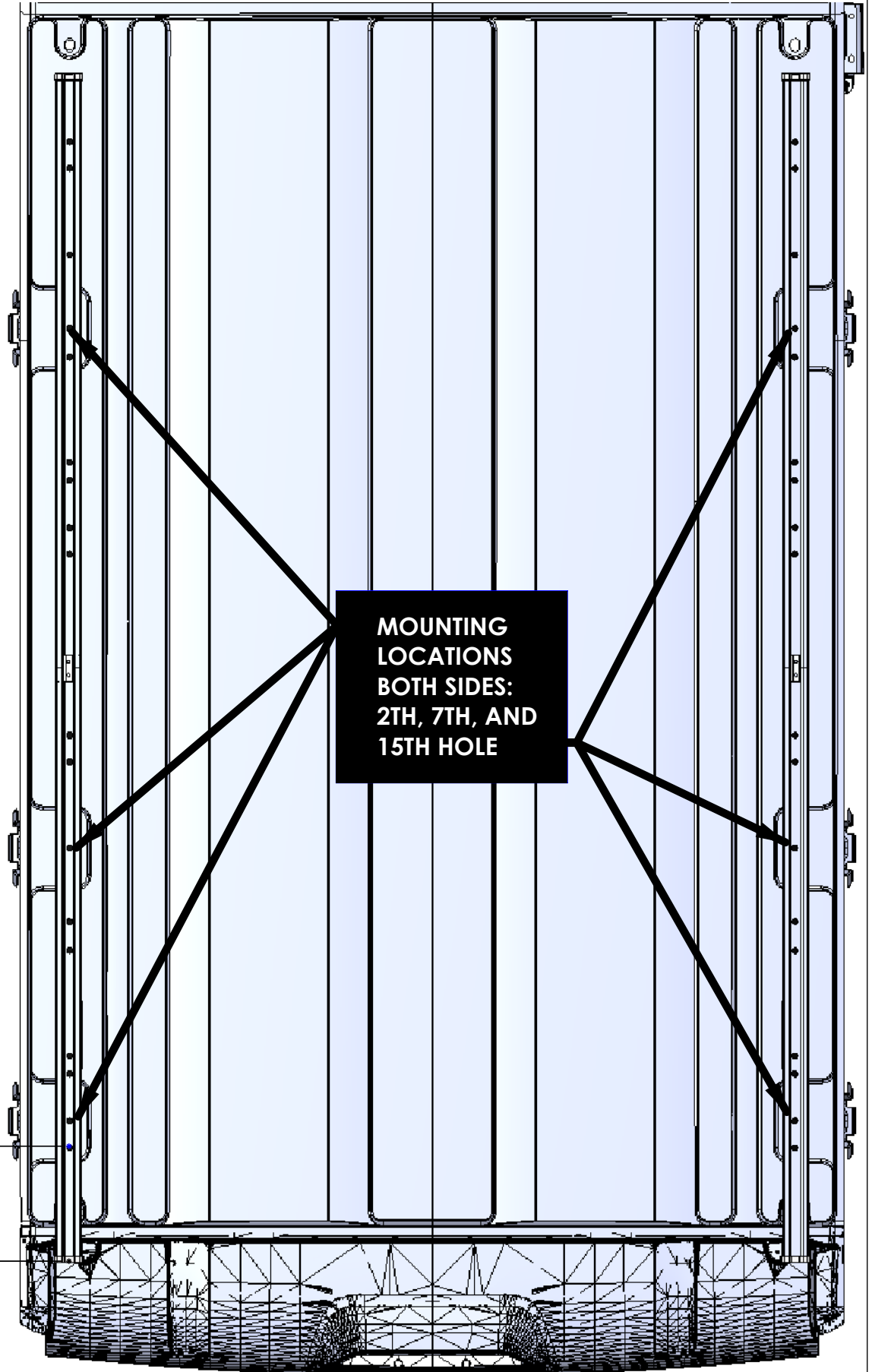

INSTALL ROOF RAILS - 148EXTENDED WHEEL BASE

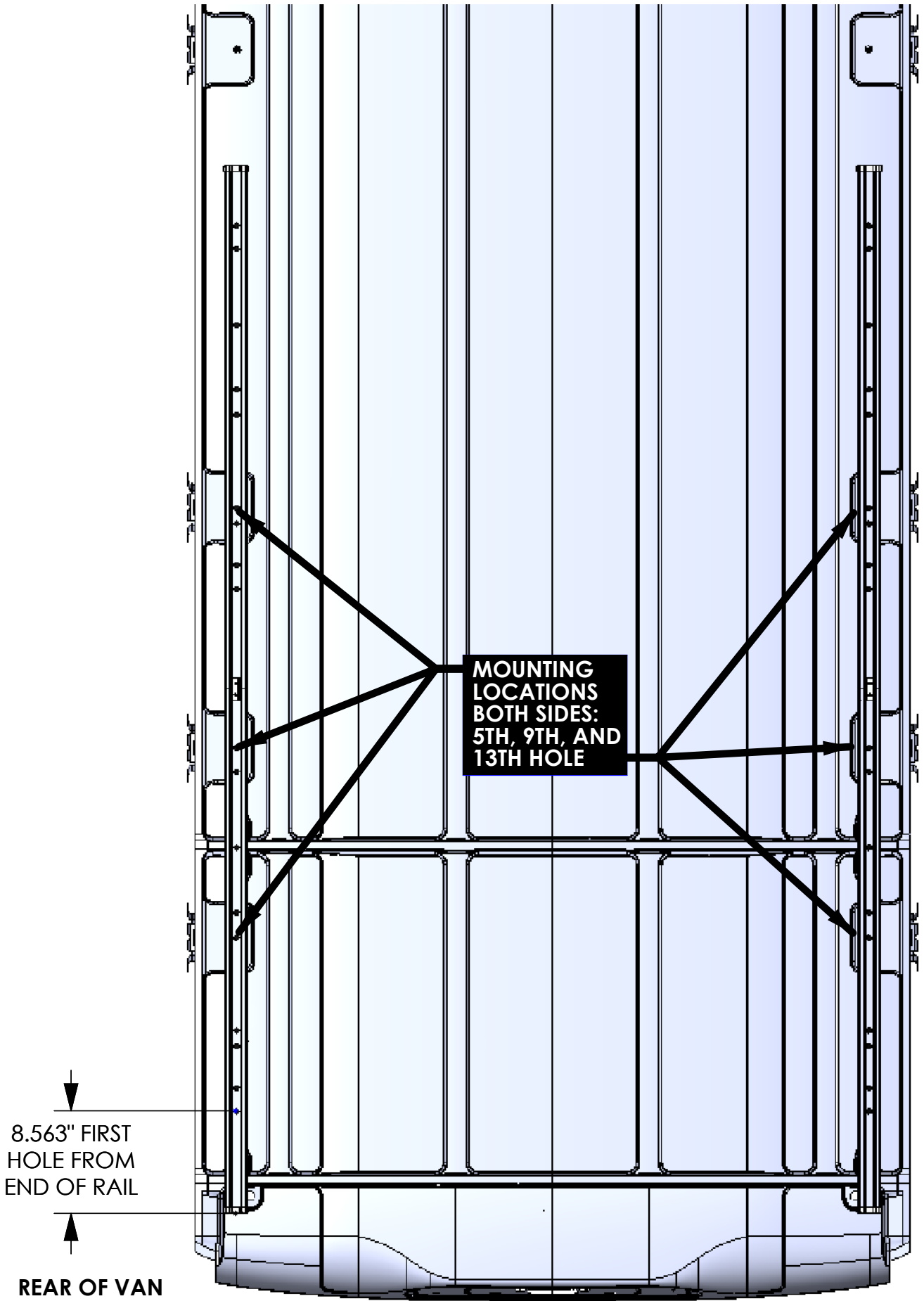

CONNECT ROOF RAILS

**SLIDE RAILS TOGETHER. CENTER SLIDE BETWEEN TWO
RAILS AND TIGHTEN DOWN SET SCREWS**

63491
FAS0497 X 2
5/32 ALAN WRENCH

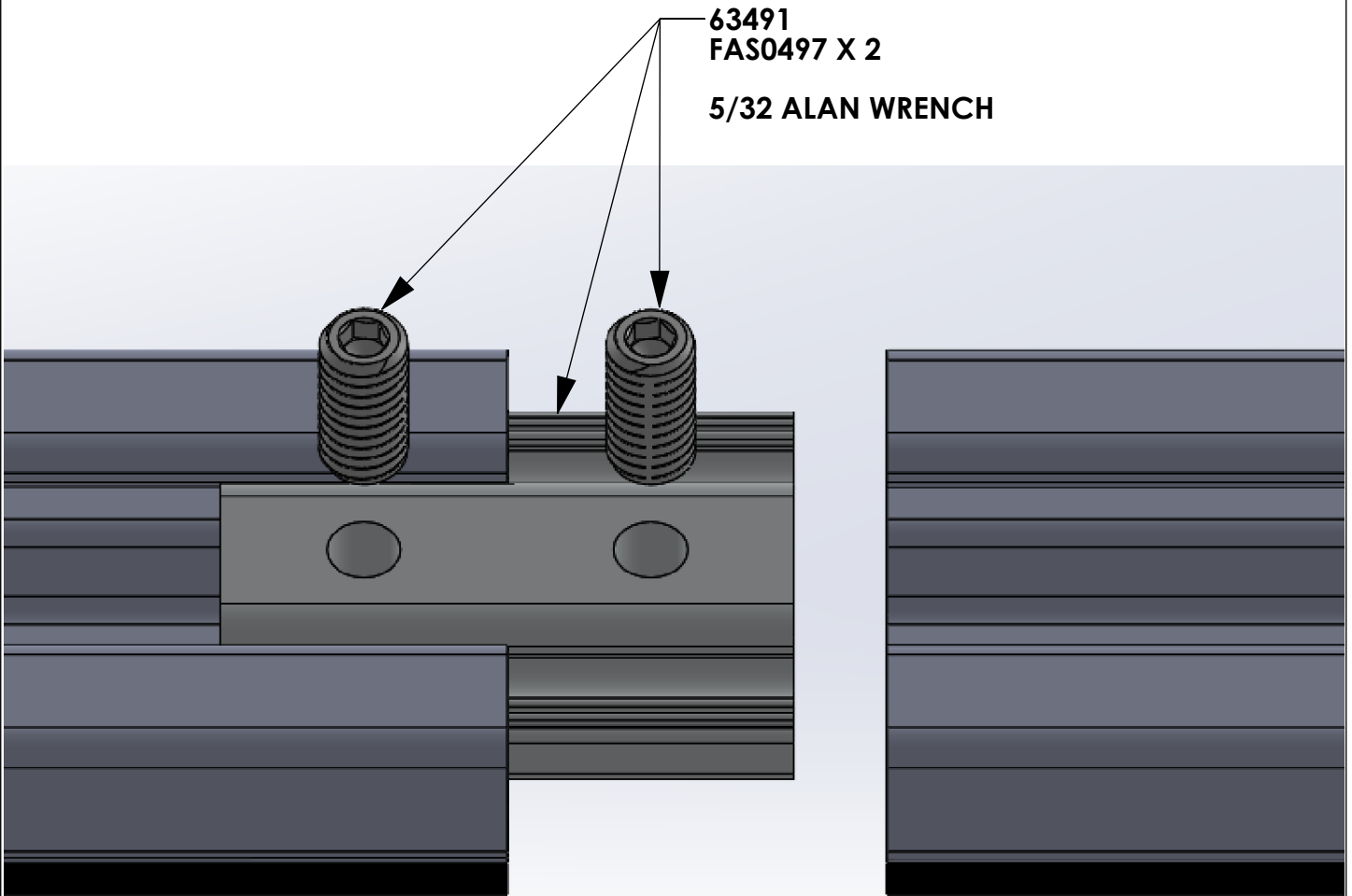

INSTALL ROOF RAILS

FAS0351 X 1
 FAS0552 X 1
 FAS0588 X 1
 05586-0 -BUTYL TAPE
 47106 X 1

(6 PLACES)

1/2" SOCKET

PLACE GASKET UNDER EACH HOLE TO BE USED (HOLE DEPENDENT ON WHEEL BASE, REFER TO PAGES 4, 5, & 6) TO INSTALL RAILS

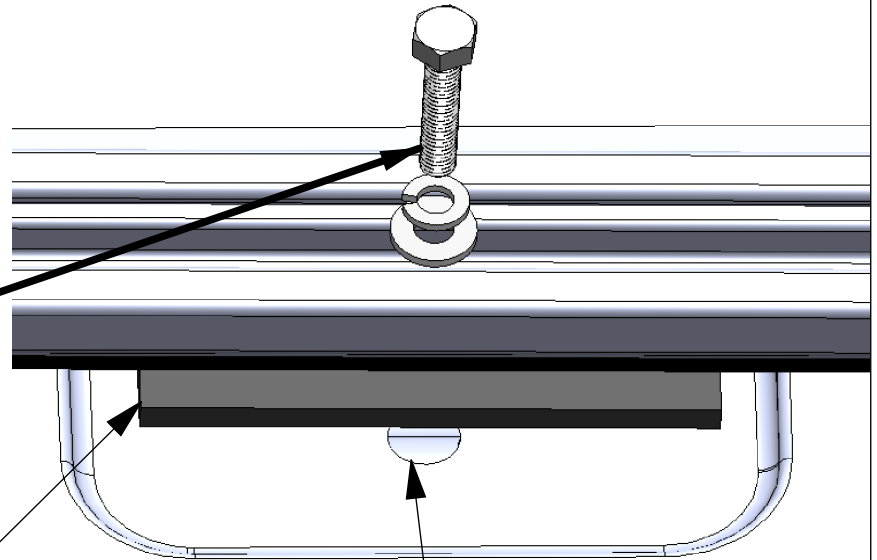

REMOVE PLASTIC PLUGS FROM SQUARE DEPRESSIONS ONLY. THESE ARE THE FACTORY MOUNTING POINTS. DO NOT REMOVE OTHER PLUGS!!! RUN M8-1.25 TAP, FULL DEPTH, TO CLEAN OUT THREADS IN OEM FASTENER IF NECESSARY. MAY HAVE TO REPEAT PROCESS TO GET GULLY CLEAN.

CAREFULLY REMOVE PLASTIC PLUGS FROM FACTORY ATTACHMENT POINTS. NOTE, THEY ARE INSTALLED PRIOR TO VEHICLE BEING PAINTED. IF ROOF CLEARANCE HOLES AND OEM FASTENER ARE MISALIGNED TOO FAR, HOLE IN ROOF SKIN MAY NEED TO BE ENLARGED (AND PRIMERED), AS WELL AS CORRESPONDING HOLE IN ROOF RAIL OF RACK. WRAP SCREWS WITH BUTYL TAPE BENEATH WASHERS, ENOUGH TO FILL HOLE IN RAIL. PUSH SCREWS THRU FOAM, AND RUBBER PAD, ADD ENOUGH SILICONE TO FILL EACH CAVITY. INSTALL SCREWS AND WASHERS AS SHOWN. TORQUE TO 10 TO 12 FT LBS. TORQUE ALL FASTENERS ON RACK ITSELF TO 10-12FT LBS. DO NOT OVER-TORQUE AS THESE ARE STAINLESS STEEL FASTENERS!



MOUNTING SCREW WITH WASHERS AND BUTYL TAPE BEFORE INSTALLATION (LEFT) AND WHAT IT SHOULD LOOK LIKE AFTER INSTALLATION (RIGHT).





Mounting Bracket Kit, 4-Pack, Black, Multiple Pickups

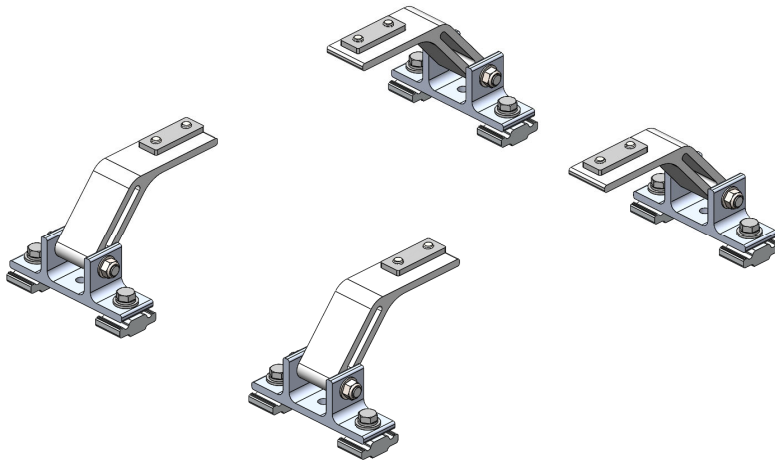

PRODUCT WEIGHT
4.0 LBS

HEIGHT OFF ROOF
SEE TABLE BELOW

CAPACITY
**REFER TO OEM'S
RECOMMENDED LOAD
RATING**
COLOR

BLACK

CATALOG NUMBER

URMBK4B

PRODUCT FEATURES

Aluminum mounting bracket kit for the PROFILE™ HD Utility, Grip-Lock, and/or ProLift ladder racks. Only works with the OEM specific, Adrian Steel supplied roof rail kit.

Utility and Grip-Lock racks are not recommended for medium or high roof vehicles!

Reference respective OEM specific roof rail kit for more detailed list of compatible accessories.

SEE PAGE 2 FOR APPLICATION NOTES AND ACCESSORIES, OTHER PRODUCTS THAT WORK WITH THIS UNIT.

PAGE 1 of 2

The information contained in this document is the sole property of ADRIAN STEEL COMPANY. ADRIAN STEEL COMPANY retains the right to modify and/or change the product of its design at any time without prior notification.



CATALOG NUMBER URMBK4B

PRODUCT APPLICATION

This product is designed to work with OEM specific rail kit for HD Utility, Grip-Lock, and/or ProLift racks. HD Utility and Grip-Lock racks are not recommended for medium or high roof vehicles!

ACCESSORIES THAT WILL WORK WITH THIS PRODUCT

CATALOG NUMBER	DESCRIPTION	CATALOG NUMBER	DESCRIPTION
RRKFT	Mounting Roof Rail Kit, Transit	RRKNVFSV	Mounting Roof Rail Kit, NV
RRKSP	Mounting Roof Rail Kit, Sprinter	RRKPM	Mounting Roof Rail Kit, ProMaster, 118" WB, 159" WB, 159" WB Extended
RRKPM136WB	Mounting Roof Rail Kit, ProMaster, 136" WB	RRKSBTOP	Mounting Roof Rail Kit, Multiple Pickups
RRKLBTOP	Mounting Roof Rail Kit, Multiple Pickups		

Reference respective OEM specific roof rail kit for more detailed list of compatible accessories.

INSTR. NUMBER : 66850	PG: 1	REV: B	ITEM NO.	PART NUMBER	DESCRIPTION	URMBK4W	URMBK2W
	PART NUMBER : URMBK		1	65123-W	UTILITY, FT MOUNT ARM, ST, W	4	2
PART DESC. : UTILITY, MNT BKT KT, RAIL			2	63852-W	UTILITY, MOUNTING BRKT, W	4	2

**-PART NUMBERS WITH "-W" SUFFIX ARE PAINTED WHITE
-FOR BLACK MOUNTING KITS, REPLACE "-W" PARTS WITH "-B" PARTS**

NOTE: THIS INSTRUCTION IS VALID FOR THE FOLLOWING KITS:

- URMBK4W
- URMBK4B
- URMBK2W
- URMBK2B

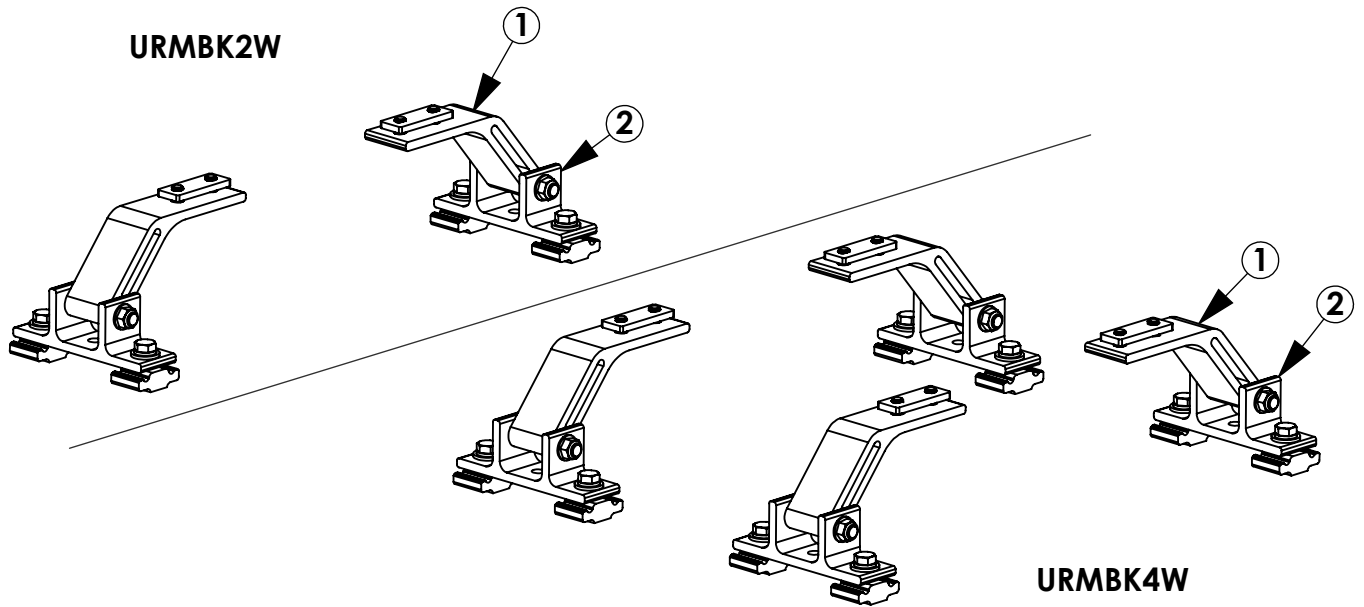

GET TO KNOW THE VEHICLE - AT THE BEGINNING OF ANY INSTALLATION, CHECK THE LOCATION OF THE FUEL TANK, FUEL LINES, BRAKE LINES, HIGH VOLTAGE BATTERIES AND WIRING HARNESSSES TO AVOID INJURY OR PROPERTY DAMAGE FROM TOOL CONTACT.

SEAL ALL EXTERIOR HOLES - ALL INSTALLATION HOLES SHOULD BE SEALED WITH BUTYL TAPE OR SILICON TO PREVENT WATER AND EXHAUST GASES FROM ENTERING THE VEHICLE.

CONTROL DRILL DEPTH - TO AVOID DAMAGE TO THE VEHICLE, USE A DRILL STOP OR CLEARED STEP BIT WHEN DRILLING INSTALLATION HOLES.

ALWAYS ADD PRIMER - WHEN ADDING INSTALLATION HOLES BE SURE TO USE A SELF-ETCHING PRIMER TO PREVENT CORROSION, FASTENER FAILURE AND INJURY.

MOUNTING POINTS MUST HAVE METAL-TO-METAL CONTACT - USE PROVIDED MOUNTING SPACERS TO ACCOMMODATE FOR VEHICLE FEATURES, CARPET OR SUBFLOORS.

PROVIDE CLEARANCE FOR SPACERS - IF THE INSTALLATION VEHICLE CONTAINS A CARPET OR SUBFLOOR, USE A 1-3/16" DIAMETER CARPET CUTTER (P/N: 31183-0) AT ALL MOUNTING LOCATIONS TO OPEN UP ROOM FOR SPACERS.

CHECK SPACER ORIENTATION - BE SURE THAT THE INDENT IN THE SPACER COVERS THE PLUSNUT HEAD; THIS ENSURES THE MOST METAL-TO-METAL CONTACT AND REDUCES VIBRATION.

PLUSNUT INSTALLATION - A PLUSNUT GUN IS RECOMMENDED FOR PLUSNUT INSTALLATION FOR ITS PRODUCTION SPEED. HOWEVER, A PLUSNUT SETTING TOOL CAN ALSO BE USED (P/N: 22200-0).

THRU-BOLT CLEARANCE - WHEN USING A THRU-BOLT AT ANY MOUNTING LOCATION, BE SURE THAT YOUR HOLE HAS 1/16" CLEARANCE.

FASTENERS USED

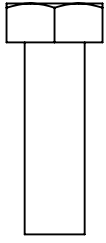

FAS0597
5/16-18X1.0 SS
HH SCREW
QTY: 8

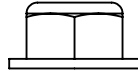

FAS0861
5/16-18 SS
HH FLG NUT
QTY: 4

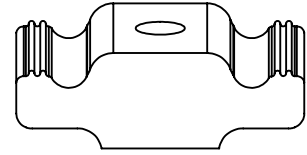

63490
RAIL SLIDE,
2"
QTY: 8

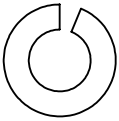

FAS0588
5/16 SS
SPLIT WASHER
QTY: 8

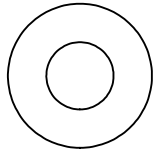

FAS0552
5/16 SS
FLAT WASHER
QTY: 12

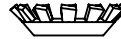

FAS0857
5/16 SS
WASHER,LCK EXT CS
QTY: 8

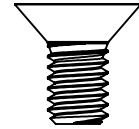

FAS0858
5/16-18X.63
FHH SCREW
QTY: 8



FAS0243
5/16-18X2.5 SS
HH SCREW
QTY: 4

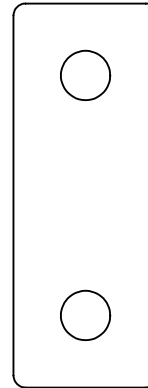

68034
PROFILE FOOT
MOUNTING PLATE
QTY: 4

STEP 1 - ASSEMBLE MOUNTING ARMS TO CROSSBOW

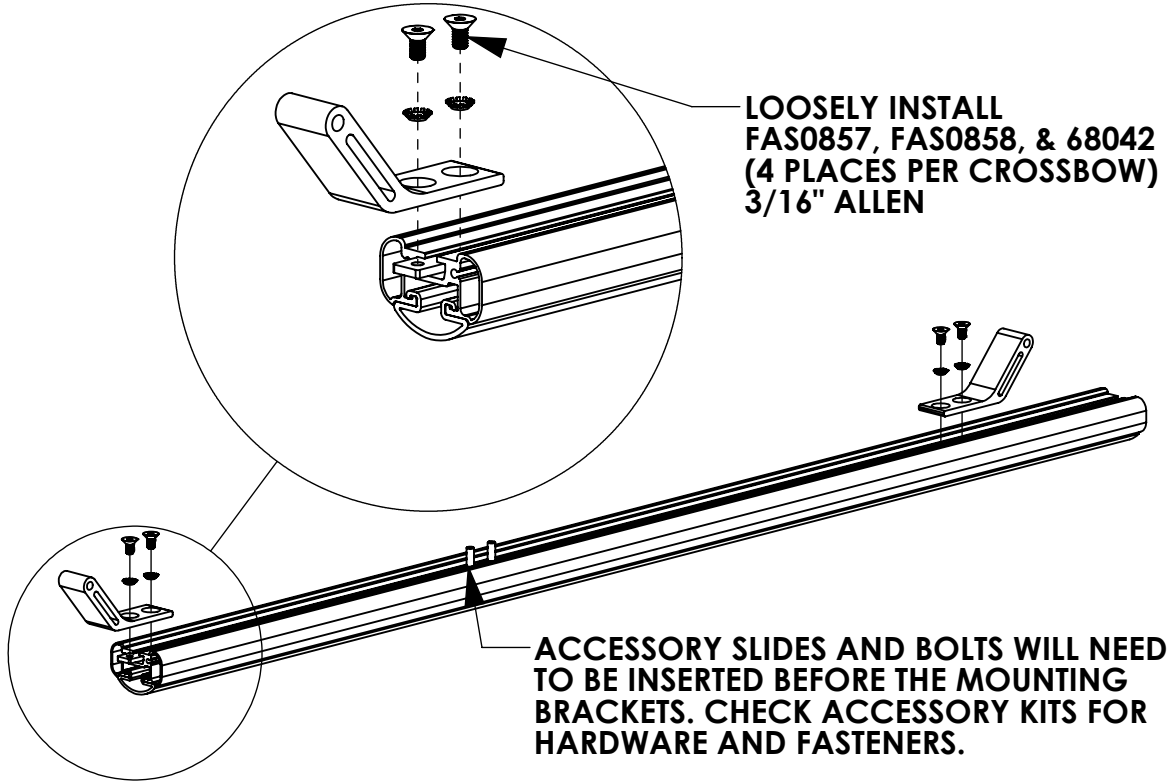

STEP 2 - ASSEMBLE MOUNTING BRACKETS TO MOUNTING ARMS

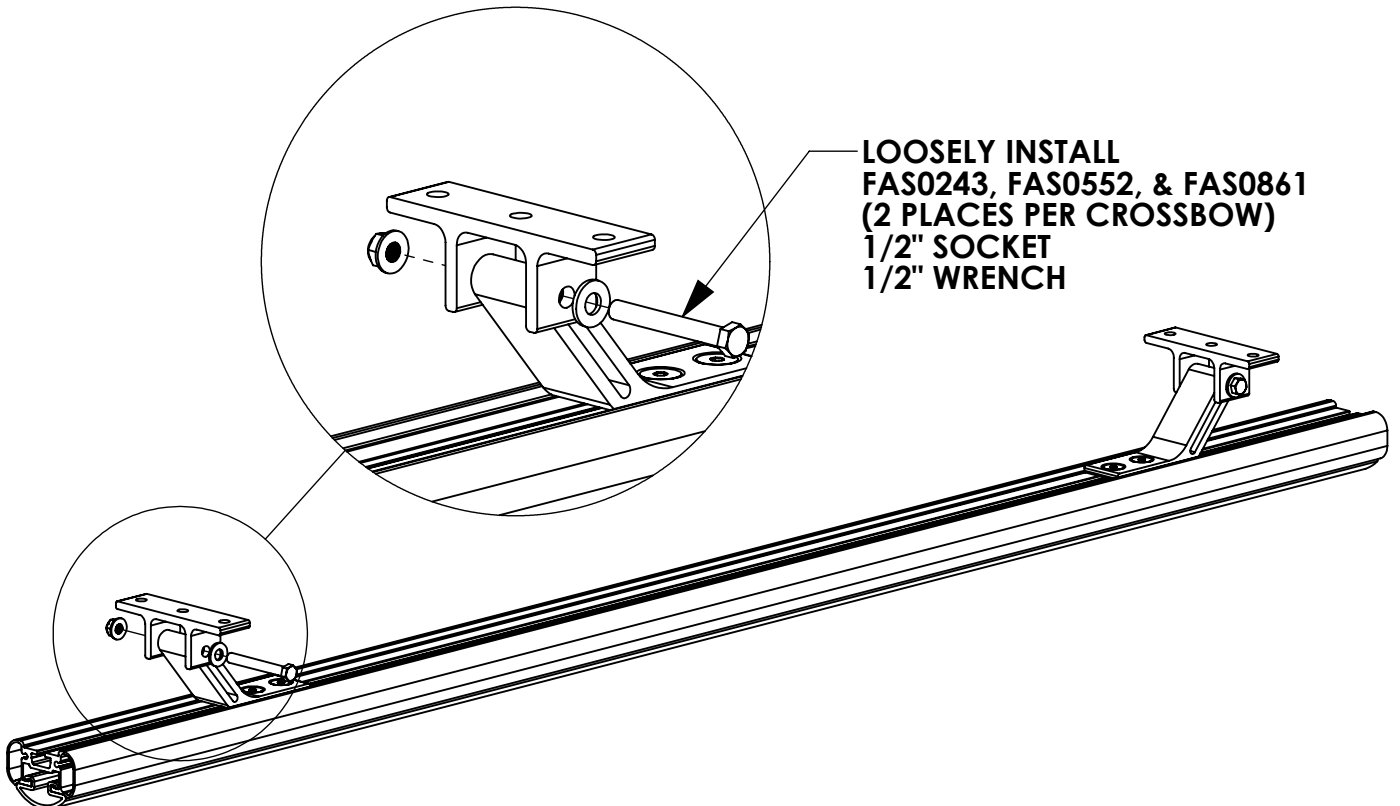

BEGIN INSTALLATION

STEP 3 - INSTALL MOUNTING BRACKETS TO RAIL

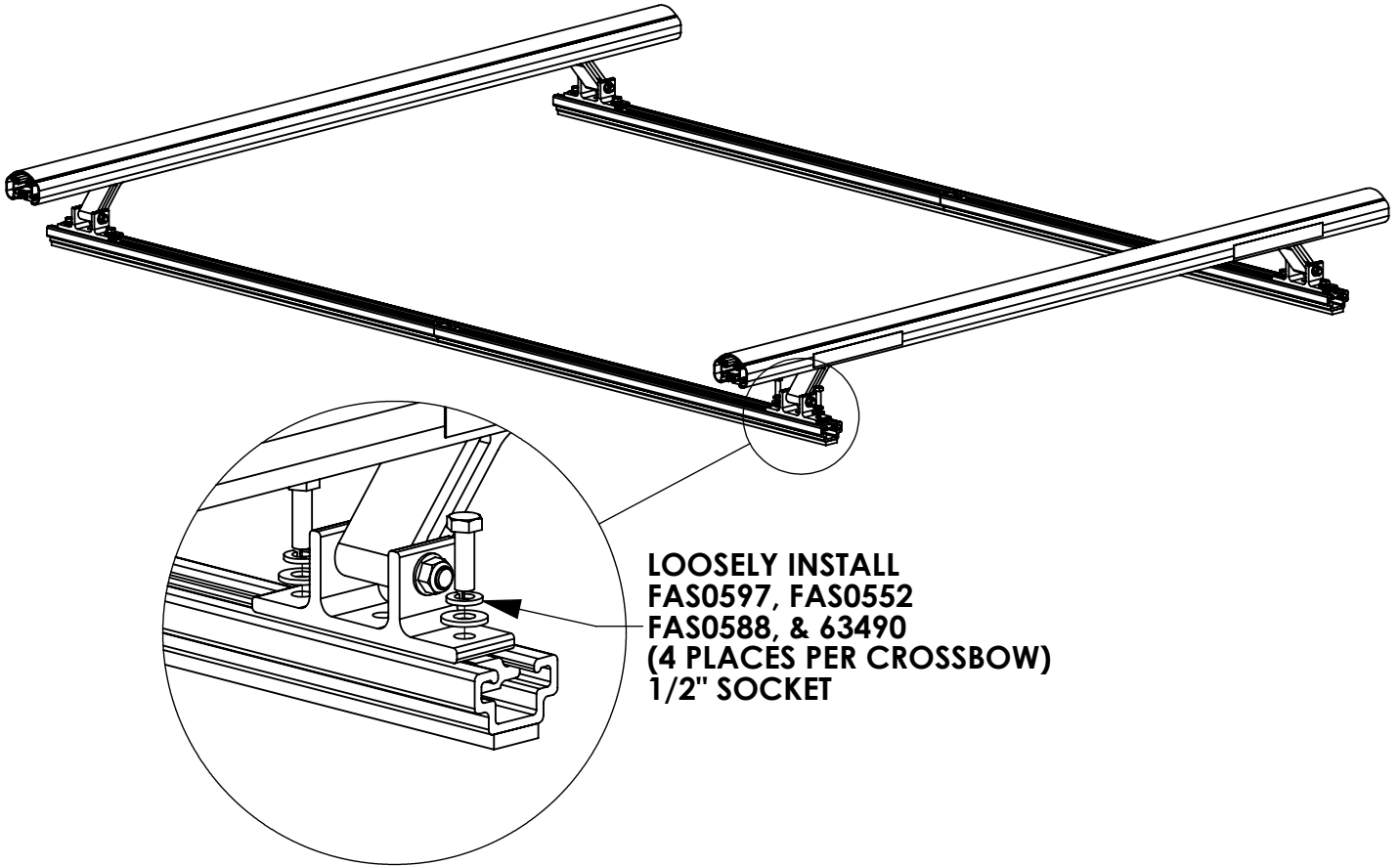

LOOSELY INSTALL
 FAS0597, FAS0552
 FAS0588, & 63490
 (4 PLACES PER CROSSBOW)
 1/2" SOCKET

CROSSBOW POSITIONING NOTES:

HD UTILITY RACK -

REAR CROSSBOW - REARWARD AS POSSIBLE
 FRONT CROSSBOW- POSITION TO BEST FIT END USER'S PRODUCT

GRIP LOCK/PROLIFT LADDER RACKS -

REFER TO RESPECTIVE INSTRUCTION FOR CROSSBOW PLACEMENT.

STEP 4 - SECURE CROSSBOW

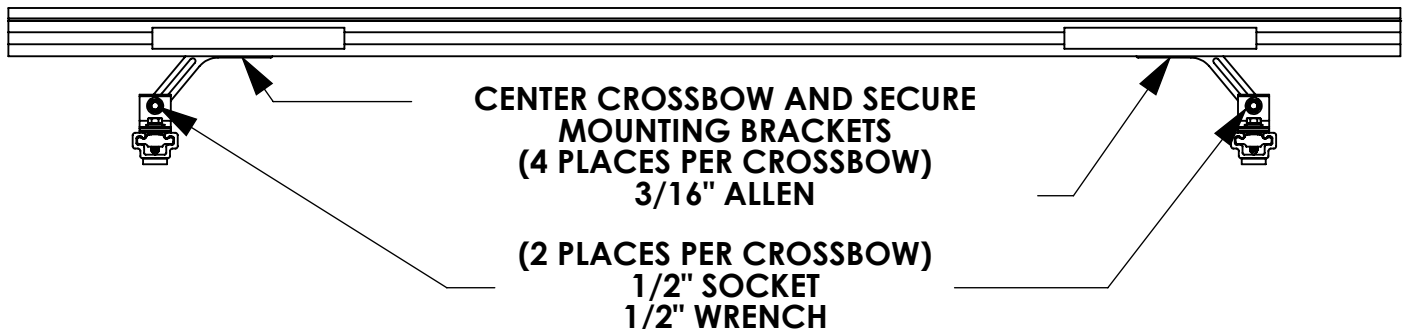

CENTER CROSSBOW AND SECURE
 MOUNTING BRACKETS
 (4 PLACES PER CROSSBOW)
 3/16" ALLEN

(2 PLACES PER CROSSBOW)
 1/2" SOCKET
 1/2" WRENCH

AFTER POSITIONING CROSSBOWS, FULLY TIGHTEN FASTENERS FROM STEP 3



2-Crossbar Kit, 58", Black, Minivan



PRODUCT WEIGHT
16.1 LBS

CROSSBOW LENGTH X
HEIGHT

59" x 2"

CAPACITY

**REFER TO OEM'S
RECOMMENDED LOAD
RATING**

COLOR

BLACK

CATALOG NUMBER

2BARCB

PRODUCT FEATURES

Aluminum base 2-crossbow kit for PROFILE™ HD Utility, Grip-Lock, ProLift, or combo ladder racks. Works with all compact van platforms for each respective wheelbase and Ford Transit Ship Thru. Works with and without OEM specific rail kit and generic mounting bracket kits.

Optional uprights and conduit kits available.

Please refer to OEM specific mounting kit or rail kit for additional information on compatible accessories.