

INSTR. NUMBER : <b>68627</b>	PG: <b>1</b>	REV: <b>A</b>	ITEM NO.	PART NUMBER	DESCRIPTION	QTY.
	PART NUMBER • <b>PLMDPSH</b> PART NUMBER • <b>PLMDDSH</b>			1	68400-W	PROLIFT,HR,DROP ASM,PS,RR, WHITE
PART • PROLIFT,MAX,PS,HR DESC. • PROLIFT,MAX,DS,HR			2	68399-W	PROLIFT,HR,DROP ASM,PS,FR, WHITE	1
			3	66959-W	DROP DOWN OUTER BAR, WELDMENT, WHITE	1
			4	66572-B	DROP DOWN, CS CENTER DRIVELINE, BLK	1
			5	48265	DAMPER ASSEMBLY	1
			6	58239	COMPRESSION DAMPER	1
			7	56330	HANDLE ASM, DDLR, HR	1
			8	68037-B	CLAMP PAD, 6.5", BLACK	2
			9	68458-B	PROLIFT,HR,INNER CLAMP,B	1
			10	68186-W	PROLIFT INNER POST, WHITE	1
			11	68628-W	PROLIFT,HR,DAMPER BRKT, W	2

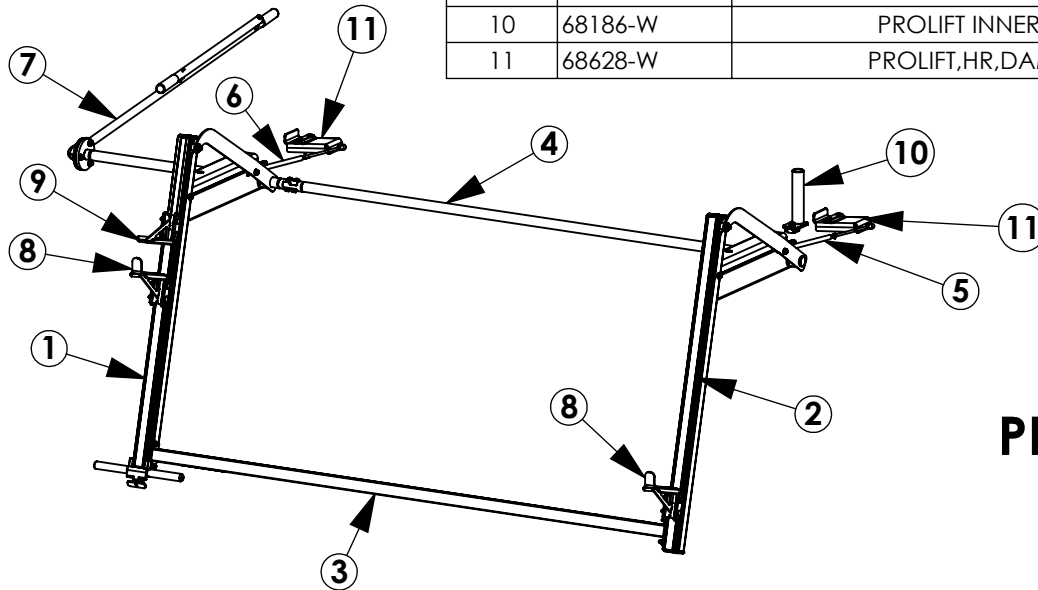

**PLMDPSHW**

ITEM NO.	PART NUMBER	DESCRIPTION	QTY.
1	68402-W	PROLIFT,HR,DROP ASM,DS,RR, WHITE	1
2	68401-W	PROLIFT,HR,DROP ASM,DS,FR, WHITE	1
3	66959-W	DROP DOWN OUTER BAR, WELDMENT, WHITE	1
4	66563-B	DROP DOWN, SS CENTER DRIVELINE, BLK	1
5	48265	DAMPER ASSEMBLY	1
6	58239	COMPRESSION DAMPER	1
7	56330	HANDLE ASM, DDLR, HR	1
8	68037-B	CLAMP PAD, 6.5", BLACK	2
9	68458-B	PROLIFT,HR,INNER CLAMP,B	1
10	68186-W	PROLIFT INNER POST, WHITE	1
11	68628-W	PROLIFT,HR,DAMPER BRKT, W	2

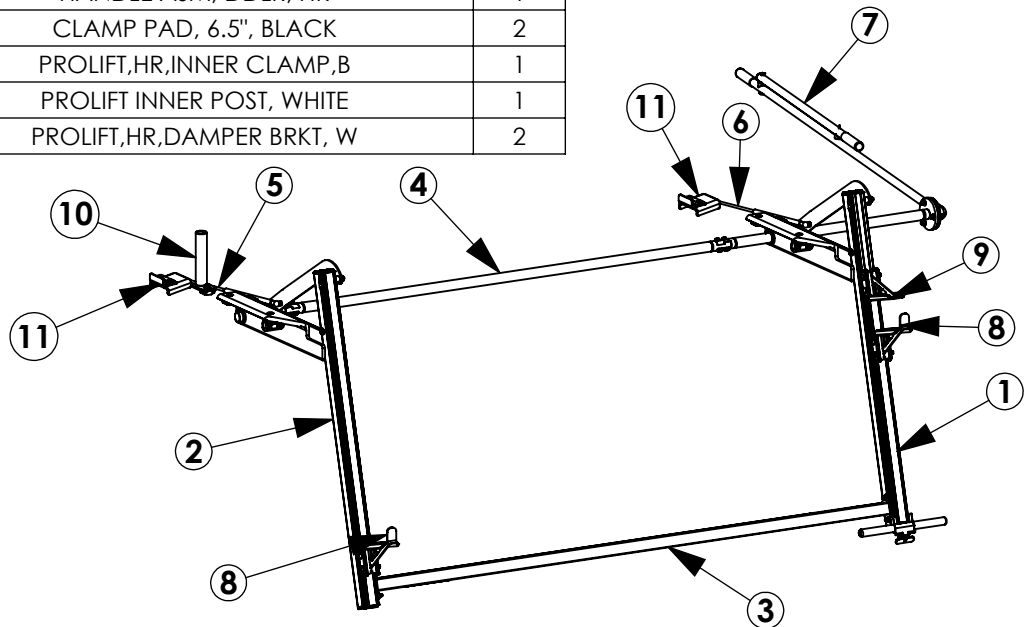

**PLMDDSHW**

**GET TO KNOW THE VEHICLE** - AT THE BEGINNING OF ANY INSTALLATION, CHECK THE LOCATION OF THE FUEL TANK, FUEL LINES, BRAKE LINES, HIGH VOLTAGE BATTERIES AND WIRING HARNESSSES TO AVOID INJURY OR PROPERTY DAMAGE FROM TOOL CONTACT.

**SEAL ALL EXTERIOR HOLES** - ALL INSTALLATION HOLES SHOULD BE SEALED WITH BUTYL TAPE OR SILICON TO PREVENT WATER AND EXHAUST GASES FROM ENTERING THE VEHICLE.

**CONTROL DRILL DEPTH** - TO AVOID DAMAGE TO THE VEHICLE, USE A DRILL STOP OR CLEARED STEP BIT WHEN DRILLING INSTALLATION HOLES.

**ALWAYS ADD PRIMER** - WHEN ADDING INSTALLATION HOLES BE SURE TO USE A SELF-ETCHING PRIMER TO PREVENT CORROSION, FASTENER FAILURE AND INJURY.

**MOUNTING POINTS MUST HAVE METAL-TO-METAL CONTACT** - USE PROVIDED MOUNTING SPACERS TO ACCOMMODATE FOR VEHICLE FEATURES, CARPET OR SUBFLOORS.

**PROVIDE CLEARANCE FOR SPACERS** - IF THE INSTALLATION VEHICLE CONTAINS A CARPET OR SUBFLOOR, USE A 1-3/16" DIAMETER CARPET CUTTER (P/N: 31183-0) AT ALL MOUNTING LOCATIONS TO OPEN UP ROOM FOR SPACERS.

**CHECK SPACER ORIENTATION** - BE SURE THAT THE INDENT IN THE SPACER COVERS THE PLUSNUT HEAD; THIS ENSURES THE MOST METAL-TO-METAL CONTACT AND REDUCES VIBRATION.

**PLUSNUT INSTALLATION** - A PLUSNUT GUN IS RECOMMENDED FOR PLUSNUT INSTALLATION FOR ITS PRODUCTION SPEED. HOWEVER, A PLUSNUT SETTING TOOL CAN ALSO BE USED (P/N: 22200-0).

**THRU-BOLT CLEARANCE** - WHEN USING A THRU-BOLT AT ANY MOUNTING LOCATION, BE SURE THAT YOUR HOLE HAS 1/16" CLEARANCE.

**FASTENERS USED**

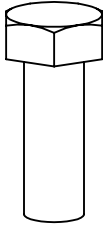

**FAS0283**  
SCREW,HH  
5/16-18X.875  
QTY: 1

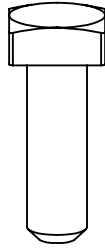

**FAS0035**  
BOLT, SQ HD  
5/16-18X1.0  
QTY: 4

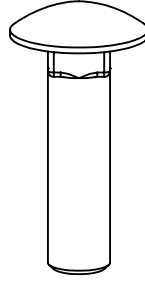

**FAS0812**  
BOLT, CRG  
5/16-18X1.25  
QTY: 4

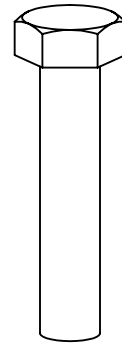

**FAS0242**  
SCREW,HH  
5/16-18X1.5  
QTY: 4

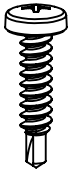

**FAS0782**  
SCREW,THP TEK  
#8X.75  
QTY: 3



**FAS0473**  
SCREW,HH TEK  
#12X.75  
QTY: 4

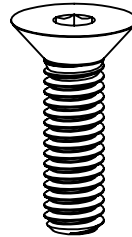

**FAS0782**  
SCREW,FHH  
5/16-18X1.125  
QTY: 4

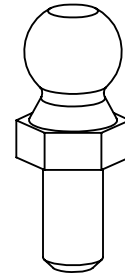

**34927-0**  
SCREW,FHH  
5/16-18X1.125  
QTY: 2



**FAS0552**  
WASHER, FLAT  
USS 5/16  
QTY: 5



**FAS0588**  
WASHER, LCK  
SPLIT 5/16  
QTY: 1



**FAS0857**  
WASHER, LCK EXT  
CS 5/16  
QTY: 4

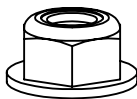

**FAS0861**  
NUT,HEX NLK  
FLG 5/16-18  
QTY: 20

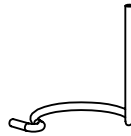

**34928-0**  
CLIP,SPRING,  
RETAINER 13MM  
QTY: 4

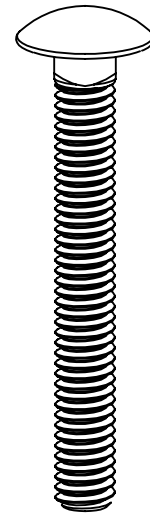

**FAS0838**  
BOLT, CRG  
5/16-18X2.5  
QTY: 6

**HARDWARE USED**

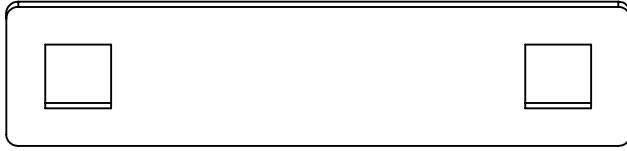

**64830**  
**REAR ROLLER,**  
**BOLT PLATE**  
**QTY: 2**

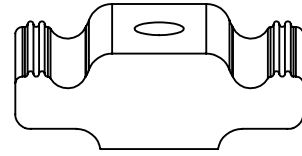

**63490**  
**RAIL SLIDE,**  
**1"**  
**QTY: 5**

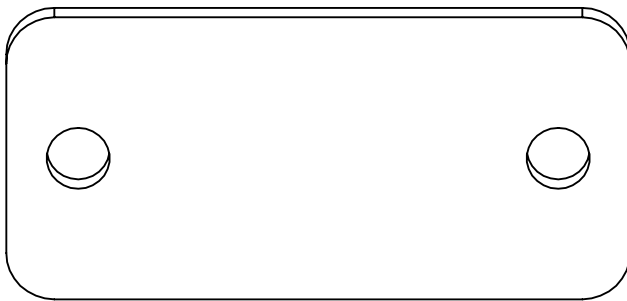

**64831**  
**REAR ROLLER,**  
**SPACER**  
**QTY: 2**

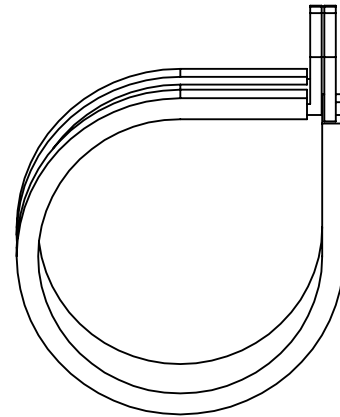

**34921-0**  
**CLAMP, CABLE**  
**1-1/2"**  
**QTY: 1**

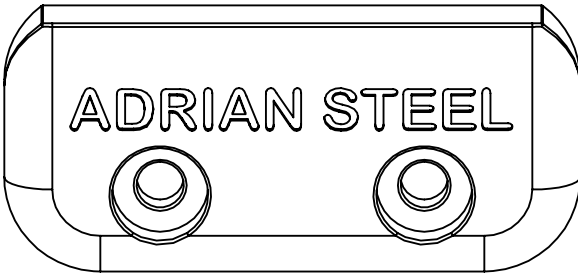

**65961**  
**DROP DOWN**  
**END CAP**  
**QTY: 2**

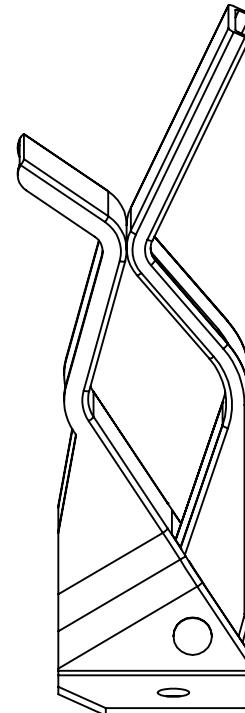

**34922-0**  
**HOLDER, TOOL**  
**QTY: 1**

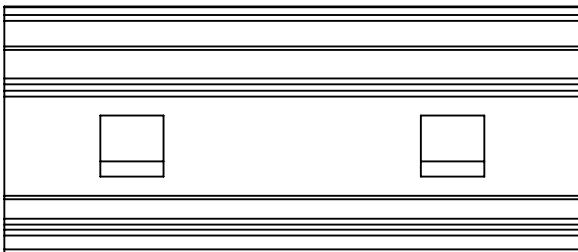

**65963-W**  
**STOP CLAMP**  
**QTY: 6**

**BEGIN ASSEMBLY**

**STEP 1 - INSTALL CLAMPS AND HARDWARE ON DROP DOWN CARTRIDGES**

**PASSENGER SIDE CARTRIDGES**

**REAR SUB-ASSEMBLY**

**FRONT SUB-ASSEMBLY**

LOOSELY INSTALL  
FAS0856, FAS0857,  
& 63490  
(4 PLACES)

LOCATION IS APPROXIMATE  
AND WILL BE ADJUSTED LATER

FAS0035  
SLIDE INTO SLOT  
(4 PLACES)

FAS0838, FAS0861  
(6 PLACES)  
1/2" SOCKET

NOTE ORIENTATION:  
SMALLER CHANNEL ON  
BOTTOM

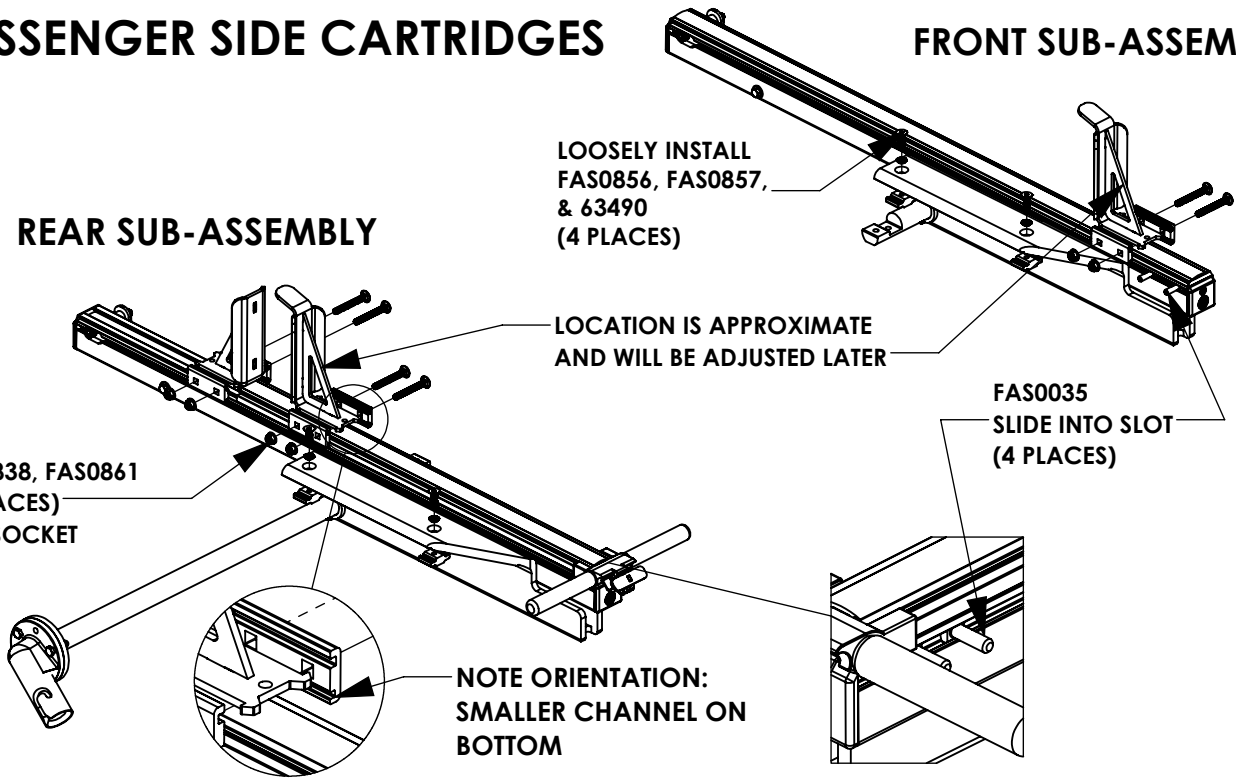

**DRIVER SIDE CARTRIDGES**

**REAR SUB-ASSEMBLY**

LOCATION IS APPROXIMATE  
AND WILL BE ADJUSTED LATER

LOOSELY INSTALL  
FAS0856, FAS0857,  
& 63490  
(4 PLACES)

FAS0035  
SLIDE INTO SLOT  
(4 PLACES)

FAS0838, FAS0861  
(6 PLACES)  
1/2" SOCKET

**FRONT SUB-ASSEMBLY**

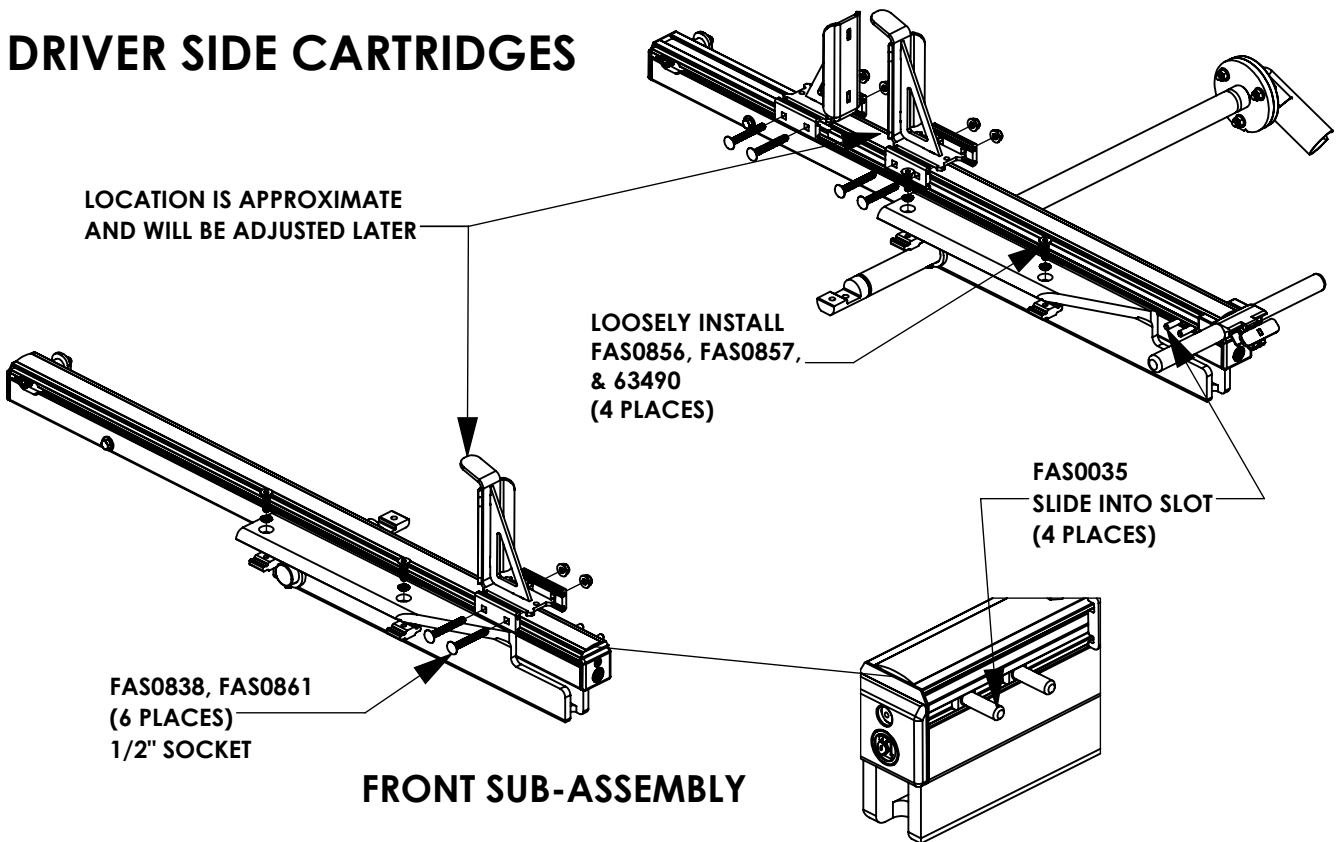

**STEP 2 - MOUNT DAMPER BRACKETS AND INNER STOPS TO CROSSBOWS**

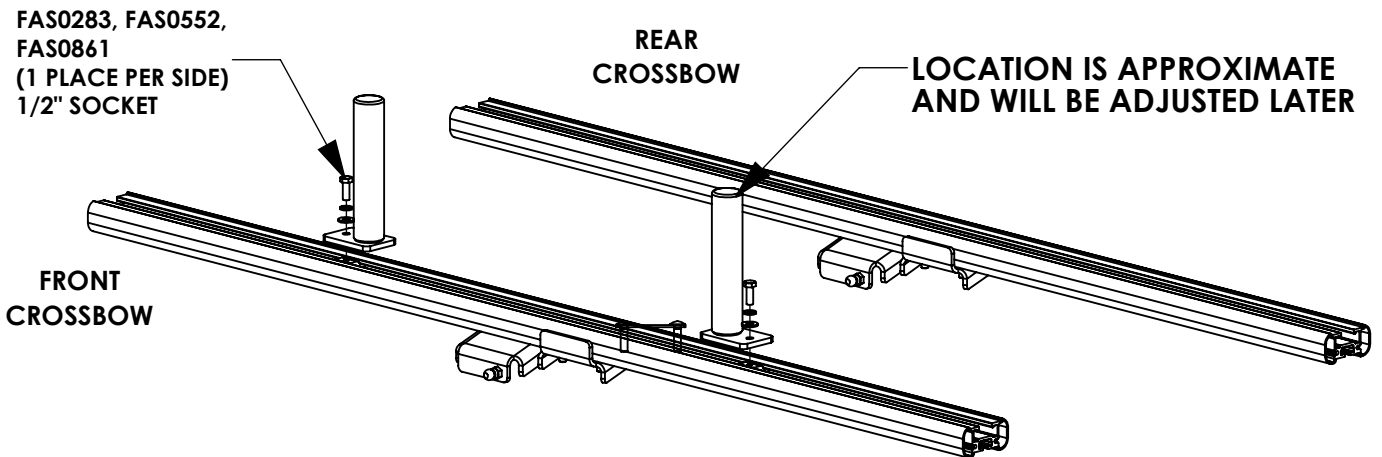
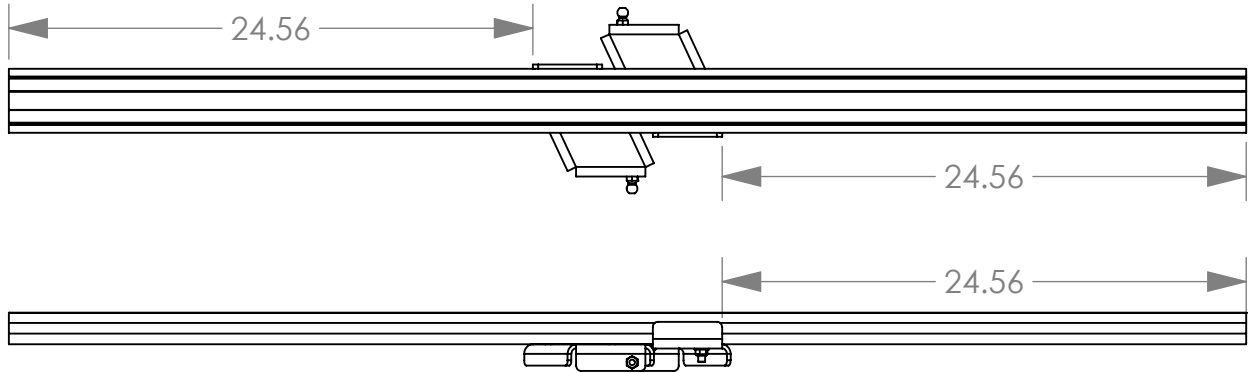
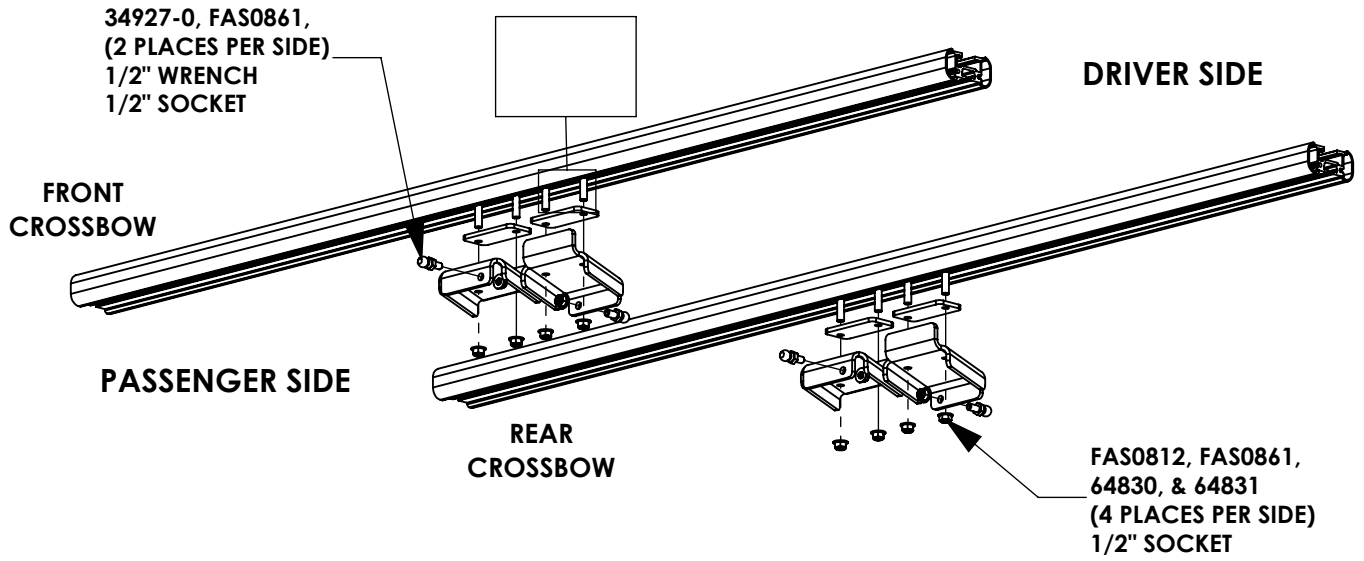

### STEP 3 - INSTALL CARTRIDGES ON CROSSBOWS

FULLY TIGHTEN  
FAS0856, FAS0857,  
& 63490  
(4 PLACES PER SIDE)  
3/16" ALLEN

PASSENGER SIDE

DRIVELINE WILL BE  
UNDER CROSSBOW

DRIVER SIDE

SLIDE CARTRIDGES  
ONTO CROSSBOWS

LINE UP CORNERS WITH  
END OF CROSSBOWS

### STEP 4 - INSTALL DAMPERS

48265  
EXTENSION DAMPER

ATTACH DAMPERS  
TO BALL STUDS

INSERT 34928-0 LOCKING  
PINS AFTER MOUNTING  
TO BALL STUDS  
(4 PLACES PER SIDE)

58239  
COMPRESSION DAMPER



### STEP 5 - INSTALL DRIVELINE AND O.S. BAR

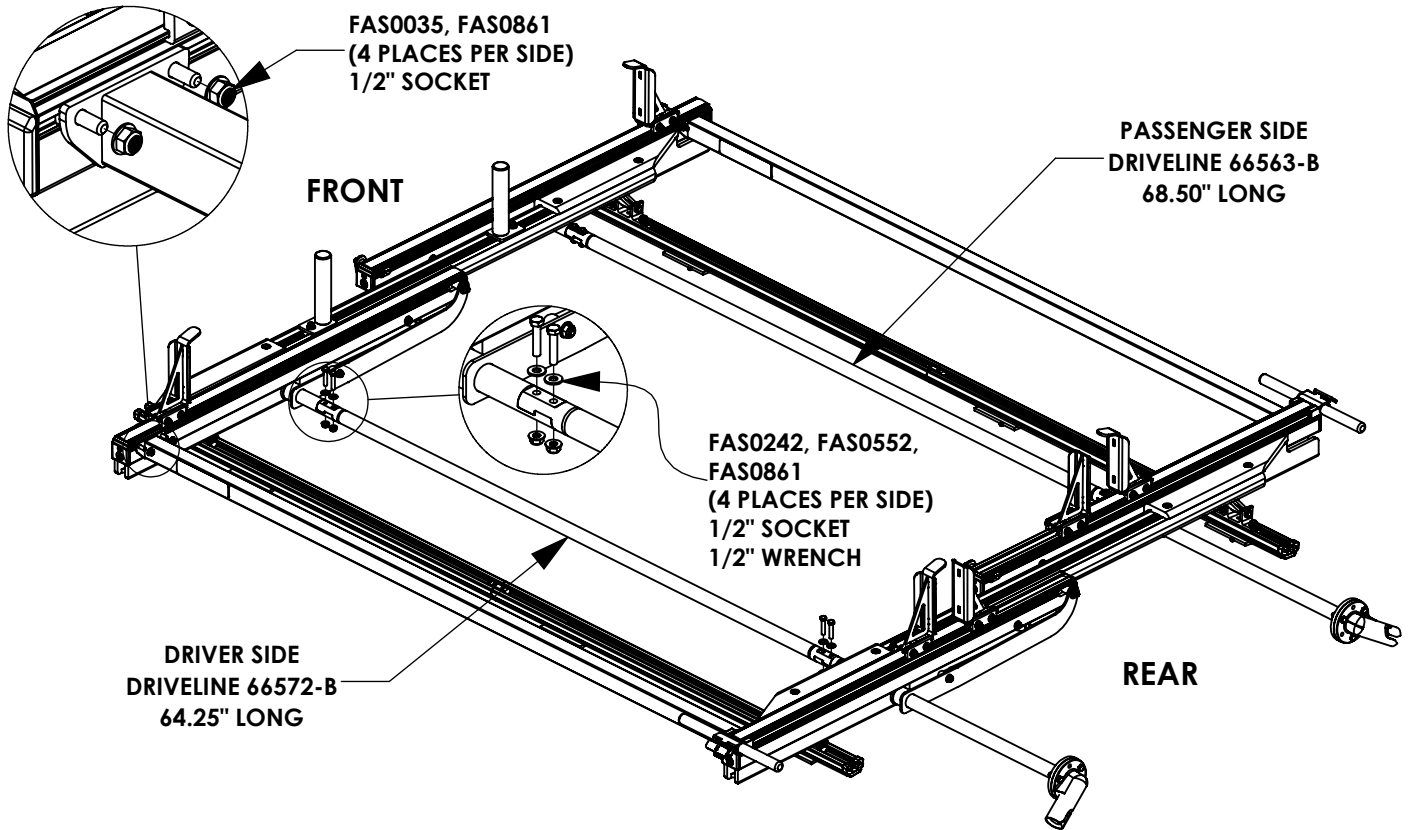

### STEP 6 - INSTALL CROSSBOW END CAPS

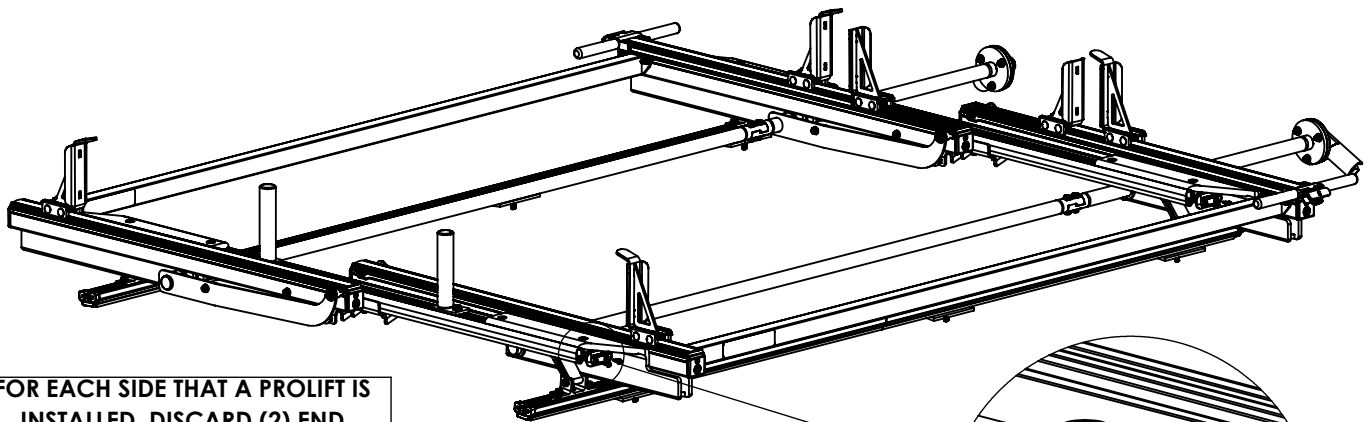

FOR EACH SIDE THAT A PROLIFT IS  
INSTALLED, DISCARD (2) END  
CAPS THAT ARE INCLUDED WITH  
THE CROSSBOW KIT.

SHOWN BELOW:



65961, (2) FAS0473  
(2 PLACES PER SIDE)  
5/16" SOCKET

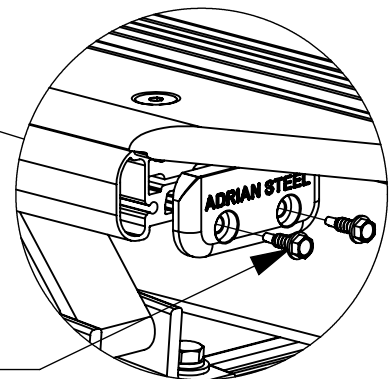



**STEP 7 - INSTALL HANDLE STORAGE HARDWARE**

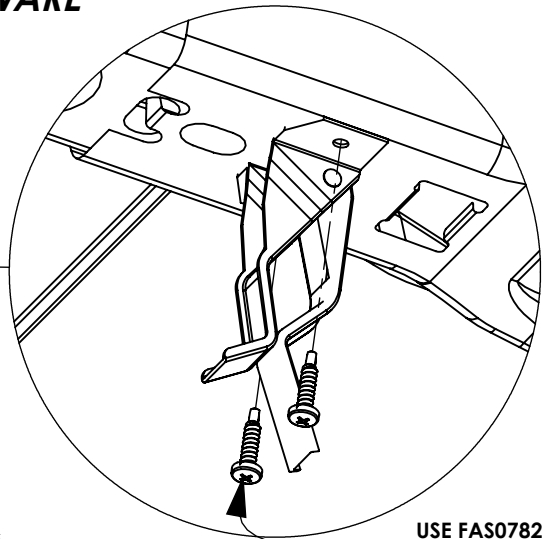

USE FAS0782  
(3 PLACES)  
#2 PHILLIPS

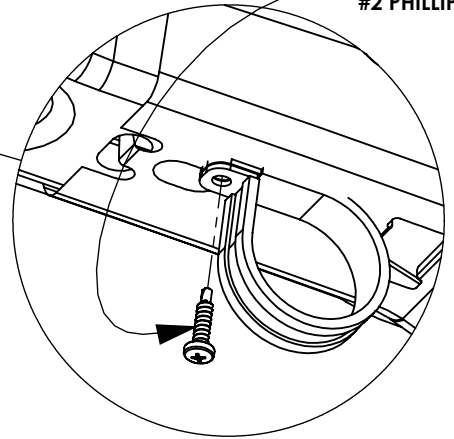

**STEP 8 - CLIP HANDLE INTO STORAGE CLIP**

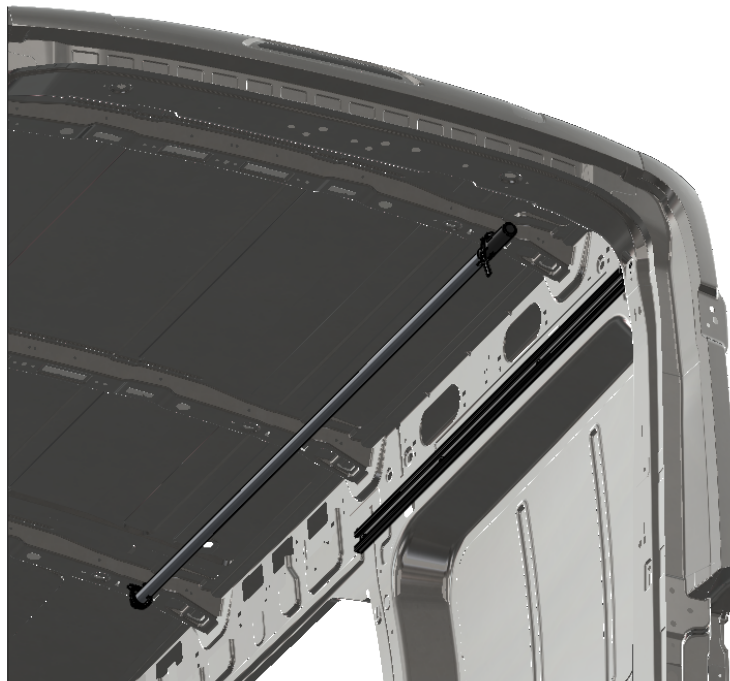

<b>INSTR. NUMBER : 64712</b> <b>PG: 1</b> <b>REV: C</b>	<b>ITEM NO.</b>	<b>PART NUMBER</b>	<b>DESCRIPTION</b>	<b>SPRMBK4W</b>	<b>SPRMBK2W</b>
	1	63911	UTILITY, PM MOUNT PLATE	4	2
	2	68202-W	PROFILE, MOUNTING ARM, W	4	2
<b>PART NUMBER : SPRMBK</b>	3	63852-W	UTILITY, MOUNTING BRKT, W	4	2
<b>PART • UTILITY,MNT BKT,SP RL</b> <b>DESC. •</b>	<b>-PART NUMBERS WITH "-W" SUFFIX ARE PAINTED WHITE</b> <b>-FOR BLACK MOUNTING KITS, REPLACE "-W" PARTS WITH "-B" PARTS</b>				

**NOTE: THIS INSTRUCTION IS VALID FOR THE FOLLOWING KITS TO MOUNT TO THE SPRINTER OEM ROOF RAIL:**

- SPRMBK4W
- SPRMBK2W
- SPRMBK4B
- SPRMBK2B

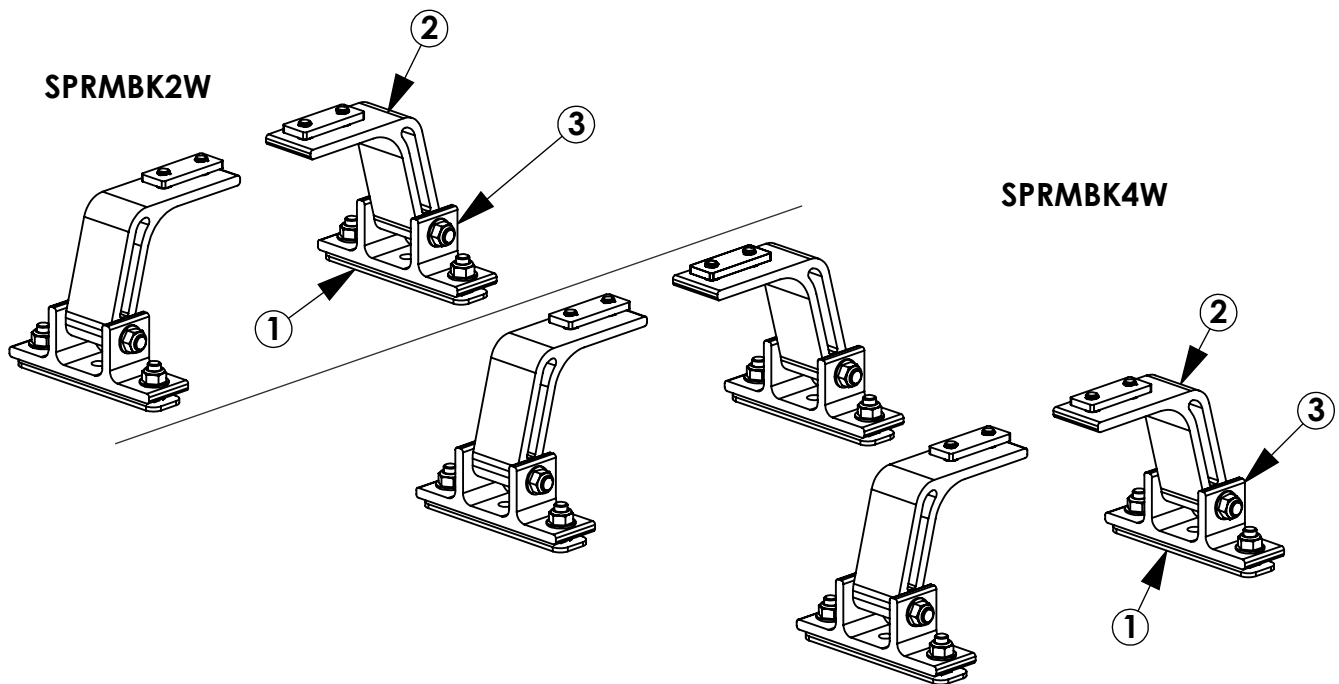

**GET TO KNOW THE VEHICLE** - AT THE BEGINNING OF ANY INSTALLATION, CHECK THE LOCATION OF THE FUEL TANK, FUEL LINES, BRAKE LINES, HIGH VOLTAGE BATTERIES AND WIRING HARNESSSES TO AVOID INJURY OR PROPERTY DAMAGE FROM TOOL CONTACT.

**SEAL ALL EXTERIOR HOLES** - ALL INSTALLATION HOLES SHOULD BE SEALED WITH BUTYL TAPE OR SILICON TO PREVENT WATER AND EXHAUST GASES FROM ENTERING THE VEHICLE.

**CONTROL DRILL DEPTH** - TO AVOID DAMAGE TO THE VEHICLE, USE A DRILL STOP OR CLEARED STEP BIT WHEN DRILLING INSTALLATION HOLES.

**ALWAYS ADD PRIMER** - WHEN ADDING INSTALLATION HOLES BE SURE TO USE A SELF-ETCHING PRIMER TO PREVENT CORROSION, FASTENER FAILURE AND INJURY.

**MOUNTING POINTS MUST HAVE METAL-TO-METAL CONTACT** - USE PROVIDED MOUNTING SPACERS TO ACCOMMODATE FOR VEHICLE FEATURES, CARPET OR SUBFLOORS.

**PROVIDE CLEARANCE FOR SPACERS** - IF THE INSTALLATION VEHICLE CONTAINS A CARPET OR SUBFLOOR, USE A 1-3/16" DIAMETER CARPET CUTTER (P/N: 31183-0) AT ALL MOUNTING LOCATIONS TO OPEN UP ROOM FOR SPACERS.

**CHECK SPACER ORIENTATION** - BE SURE THAT THE INDENT IN THE SPACER COVERS THE PLUSNUT HEAD; THIS ENSURES THE MOST METAL-TO-METAL CONTACT AND REDUCES VIBRATION.

**PLUSNUT INSTALLATION** - A PLUSNUT GUN IS RECOMMENDED FOR PLUSNUT INSTALLATION FOR ITS PRODUCTION SPEED. HOWEVER, A PLUSNUT SETTING TOOL CAN ALSO BE USED (P/N: 22200-0).

**THRU-BOLT CLEARANCE** - WHEN USING A THRU-BOLT AT ANY MOUNTING LOCATION, BE SURE THAT YOUR HOLE HAS 1/16" CLEARANCE.

***FASTENERS USED***

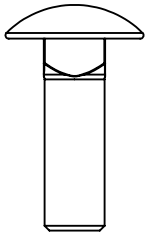

**FAS0398**  
**5/16-18X1.0 SS**  
**CRG BOLT**  
**QTY: 8**

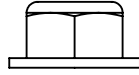

**FAS0861**  
**5/16-18 SS**  
**HH FLG NUT**  
**QTY: 12**

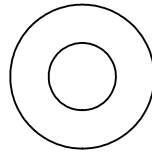

**FAS0552**  
**5/16 SS**  
**FLAT WASHER**  
**QTY: 4**

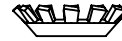

**FAS0857**  
**5/16 SS**  
**WASHER,LCK EXT CS**  
**QTY: 8**

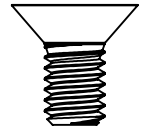

**FAS0858**  
**5/16-18X.63**  
**FHH SCREW**  
**QTY: 8**

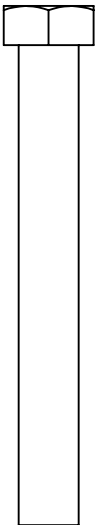

**FAS0243**  
**5/16-18X2.5 SS**  
**HH SCREW**  
**QTY: 4**



**68034**  
**PROFILE FOOT**  
**MOUNTING PLATE**  
**QTY: 4**

### STEP 1 - ASSEMBLE MOUNTING ARMS TO CROSSBOW

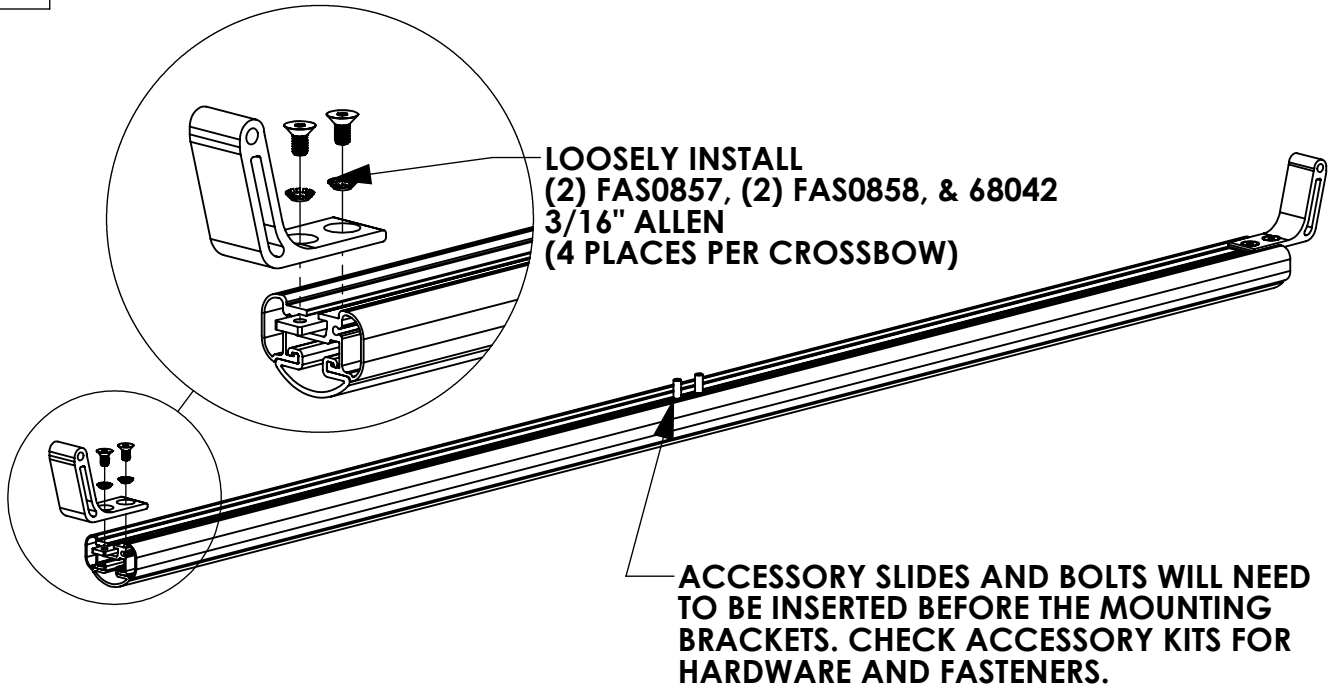

### STEP 2 - INSTALL MOUNTING BRACKETS TO VAN ROOF

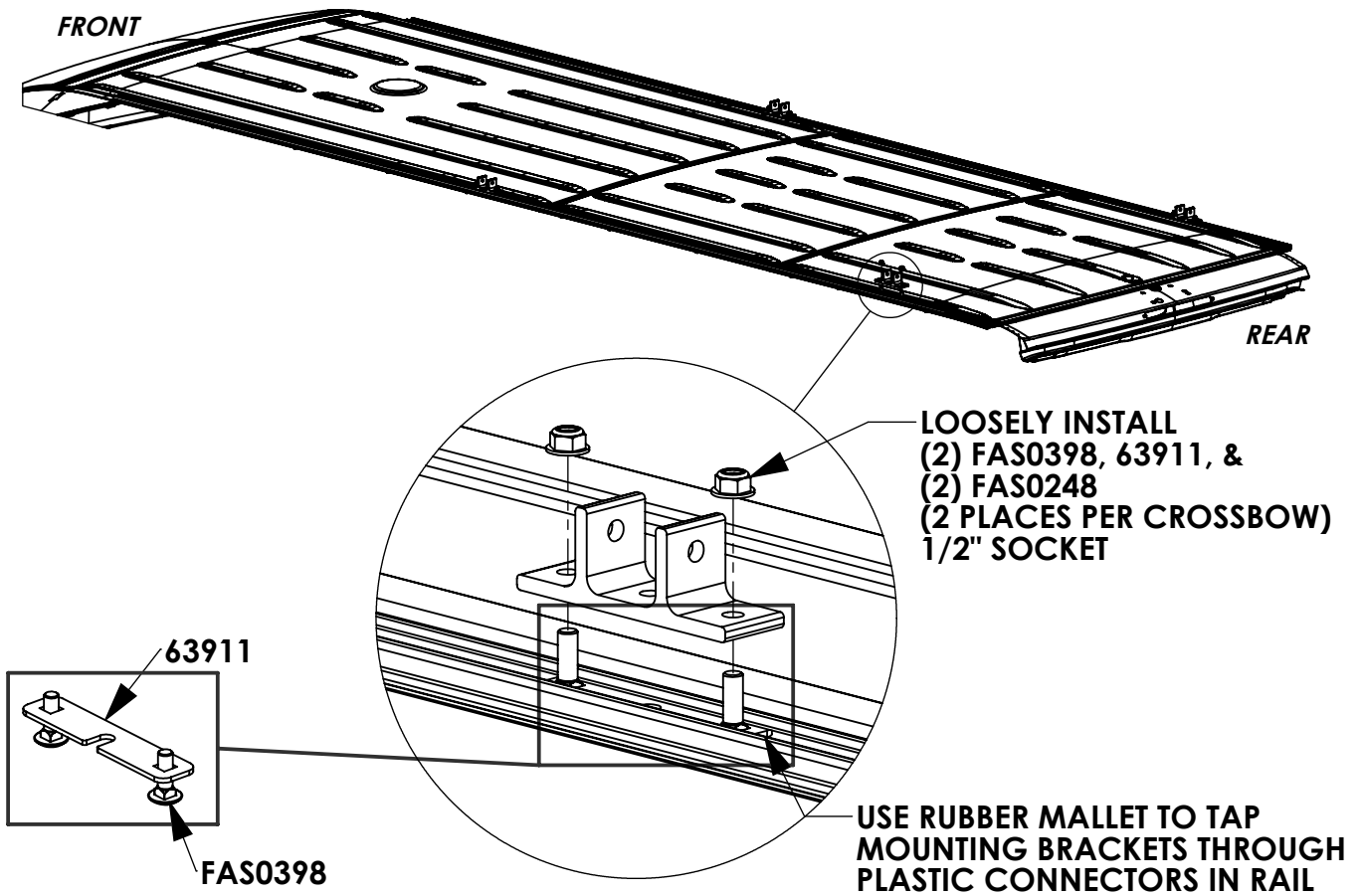

**STEP 3 - ATTACH CROSSBOW ASSEMBLY TO ROOF**

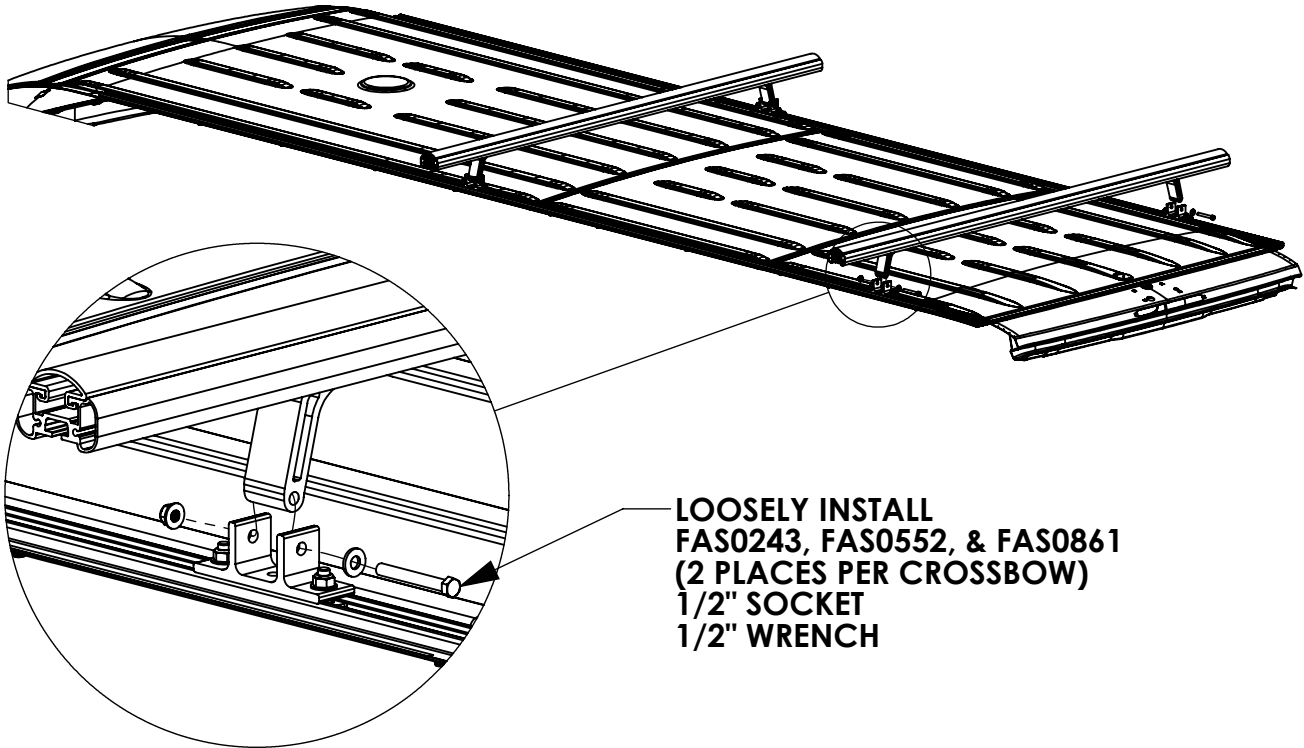

LOOSELY INSTALL  
FAS0243, FAS0552, & FAS0861  
(2 PLACES PER CROSSBOW)  
1/2" SOCKET  
1/2" WRENCH

**CROSSBOW POSITIONING NOTES:**

**HD UTILITY RACK -**

REAR CROSSBOW - REARWARD AS POSSIBLE  
FRONT CROSSBOW- POSITION TO BEST FIT END USER'S PRODUCT

**GRIP LOCK/PROLIFT LADDER RACKS -**

REFER TO RESPECTIVE INSTRUCTION FOR CROSSBOW PLACEMENT.

**STEP 4 - SECURE CROSSBOW**

CENTER CROSSBOW AND SECURE  
MOUNTING BRACKETS  
3/16" ALLEN  
(4 PLACES PER CROSSBOW)

1/2" SOCKET  
1/2" WRENCH  
(2 PLACES PER CROSSBOW)

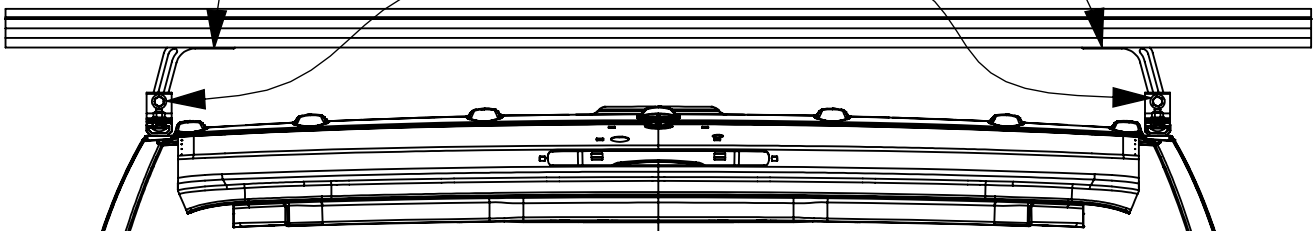

**AFTER POSITIONING CROSSBOWS, FULLY TIGHTEN FASTENERS FROM STEP 2 & 3**



## 2-Crossbar Kit, 68", Black, Full Size Van



PRODUCT WEIGHT  
**19 LBS**

CROSSBOW LENGTH X  
HEIGHT

**69" x 2"**

CAPACITY

**REFER TO OEM'S  
RECOMMENDED LOAD  
RATING**

COLOR

**BLACK**

CATALOG NUMBER

**2BARB**

### PRODUCT FEATURES

Aluminum base 2-crossbow kit for PROFILE™ HD Utility, Grip-Lock, ProLift, or combo ladder racks. Works with all full size van platforms for each respective wheelbase and roof height combination. Works with and without OEM specific rail kit and generic mounting bracket kits.

Additional crossbows and optional uprights, conduit kits, and rear rollers available.

Utility and grip lock ladder racks are not recommended for medium and high roof vehicles!

Please refer to OEM specific mounting kit or rail kit for additional information on compatible accessories.