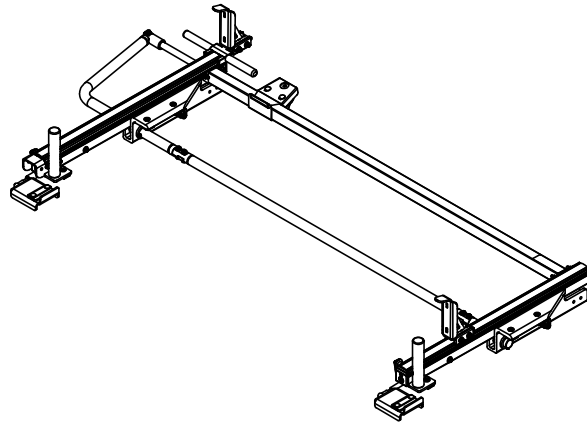

**ADRIAN STEEL®**

Cargo Management Solutions for Commercial Vehicles

PROLIFT MAX DROP 4' DRIVERS SIDE LOW TOPPER LADDER RACKS

PRODUCT WEIGHT**63.5 LBS****WIDTH X DEPTH X HEIGHT****82.00" X 32.00" X4.00"****CAPACITY****SINGLE LADDER****COLOR****WHITE/BLACK****CATALOG NUMBER****PLMDDSLT4W, PLMDDSLT4B****PRODUCT FEATURES**

ProLift™ Max Drop LOW Topper racks can be used on ADRIAN STEEL BIFF, LEER, UNICOVER and ARE truck toppers with bed lengths from 4'6" - 6'1" with appropriate rail kit, crossbow kit and mounting bracket kit. Use rail kits, crossbow kits, and mounting bracket kits listed in the table below to create new rack combinations. These racks include an attached handle.

The Max-Drop ProLift™ has a single function that lowers the ladder to a single set height and a secondary function that lowers the rear of the ladder even further to a safer more ergonomic height. Most similar to our previous DDLR drop-down series.

Unicover Toppers will use roof rail kits ending in UC (Ex. 4'6" Unicvoer topper would use RRKTOP55UC)

Ignore the roof rail kit when ordering racks for ASC BIFF toppers as they ship with pre-installed rails.

Commercial Part Numbers

Vehicle Platform	Bed Length	Bed Length (in)	Roof Rail Kit	Crossbow kit	Mounting Bracket Kit	Pro-Lift (Passenger Side)	Pro-Lift (Drivers Side)
Maverick	4'6"	54"	RRKTOP55/UC	2BARTOPW	MAVRMBK4W	PLSDPSLT4	PLSDDSLT4
All	4'10" - 5'6"	58" - 66"	RRKTOP58/UC	2BARTOPW	URMBK4W	PLSDPSLT4	PLSDDSLT4
All	5'7" - 6'1"	67"-73"	RRKTOP67/UC	2BARTOPW	URMBK4W	PLSDPSLT4	PLSDDSLT4

NOTE:CROSSBAR KIT IS DIFFERENT FOR COMBO WITH GRIPLOCK. IN THIS CASE,USE 2BAR53W/B

SEE PAGE 2 FOR APPLICATION NOTES, ACCESSORIES AND OTHER PRODUCTS THAT WORK WITH THIS UNIT.

**PROLIFT MAX DROP 4' DRIVERS SIDE
LOW TOPPER LADDER RACKS****CATALOG NUMBER****PLMDDSLT4W, PLMDDSLT4B****PRODUCT APPLICATION****TOPPER PROLIFT LADDER RACKS ARE FOR USE ON PICKUP TRUCK BED TOPPERS,
AVAILABLE IN 4 FT, 5 FT, AND 6 FT LENGTHS FOR ALL DIFFERENT SIZE TRUCK BEDS.****Reduce back and shoulder injuries while loading/unloading ladders by
eliminating the need to climb on bumpers and tires to reach the cargo on the
roof of your vehicle.****The ProLift™ uses unique, patent-pending, mechanical advantages, and
high-performing spring assist struts to raise and lower ladders with an almost
effortless pull.****ACCESSORIES THAT WILL WORK WITH THIS PRODUCT**

CATALOG NUMBER	DESCRIPTION (smart)
RRKTOP55	ROOF RAIL KIT, TOPPER, 55"
RRKTOP58	ROOF RAIL KIT, TOPPER, 58"
RRKTOP67	ROOF RAIL KIT, TOPPER, 67"
RRKTOP55UC	ROOF RAIL KIT, TOPPER, 55" UNICOVER
RRKTOP58UC	ROOF RAIL KIT, TOPPER, 58" UNICOVER
RRKTOP67UC	ROOF RAIL KIT, TOPPER, 67" UNICOVER
2BARTOPW / B	2BAR UTILITY RACK, TOP
2BAR53W / B	2BAR, CROSSBOW, 53"
URMBK4W / B	UTILITY, MNT BKT KT, RAIL
PLMDPSLT4W/B	PROLIFT, MAX, PS, LOW TOP, 4
GL-TOPPSW / B	GRIP-LOCK, TOP PS

**The information contained in this document is the sole property of ADRIAN STEEL COMPANY. ADRIAN STEEL
COMPANY retains the right to modify and/or change the product of its design at any time with prior notification.**

INSTR. NUMBER : 69483	PG: 1	REV: A
PART NUMBER • Max Drop ProLift - Low & Mid-Roof		
PART • ProLift Low & Mid-Roof DESC. • Adjustment Instructions		

**Step 2: With 1/2" Socket loosen nut, slide post so that it is snug against ladder
Tighten nut**

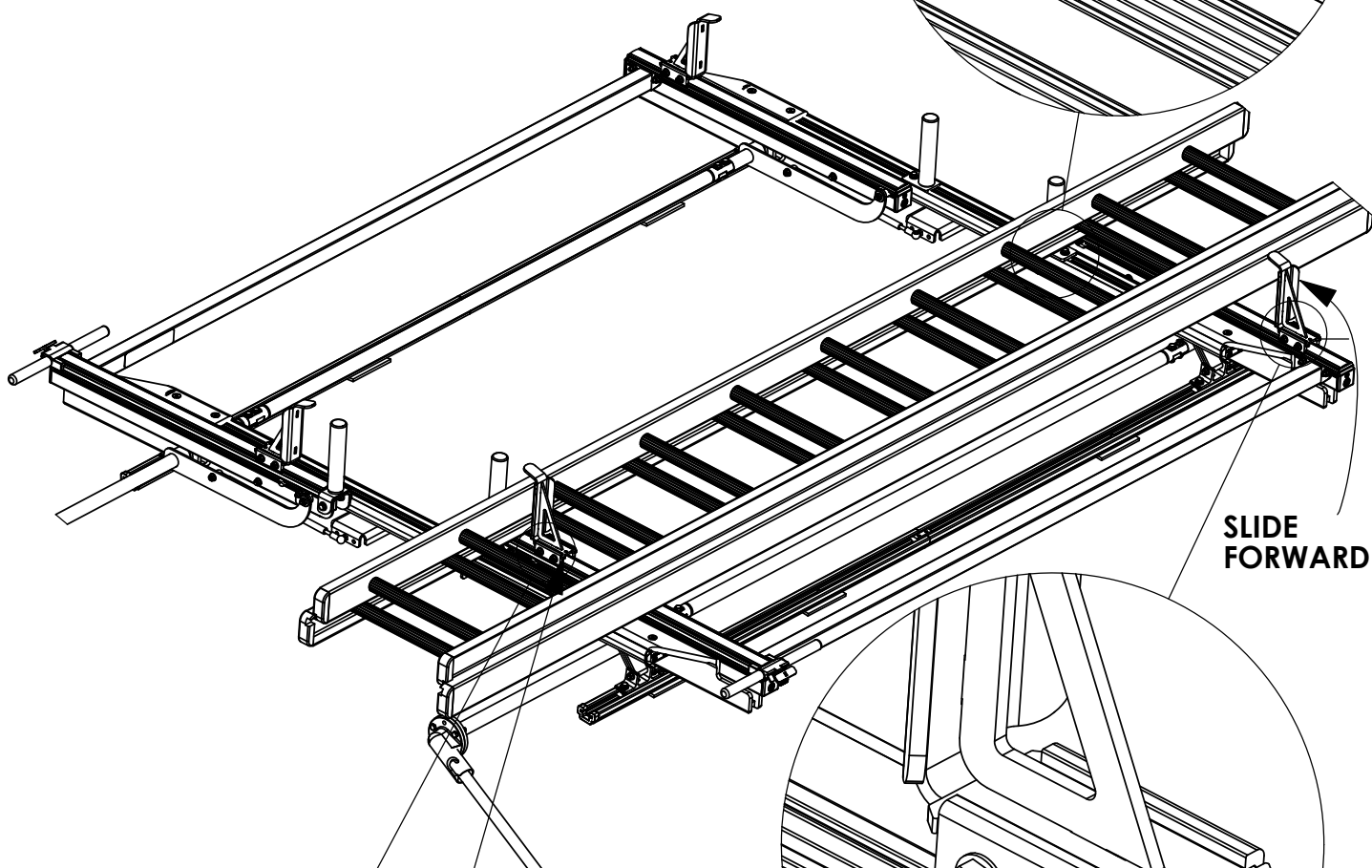
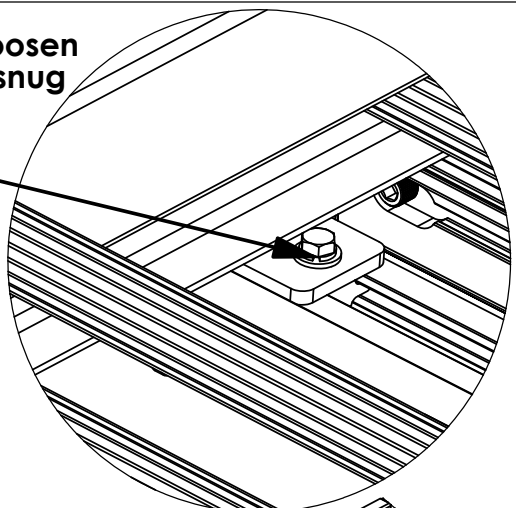

SLIDE FORWARD

SLIDE FORWARD

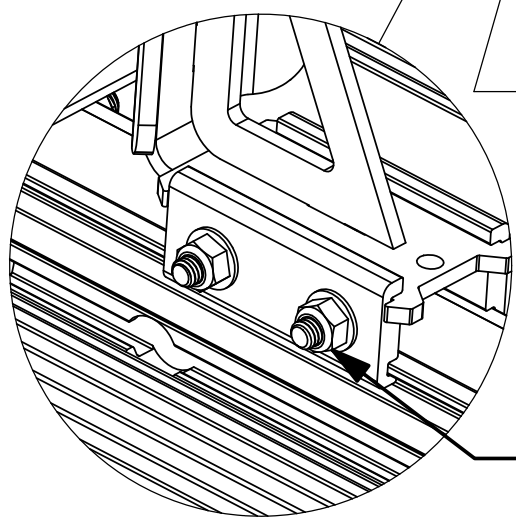

**Step 1: With 1/2" Socket loosen nuts (x2) slide clamp so that it is snug against ladder
Tighten nuts (X2)**

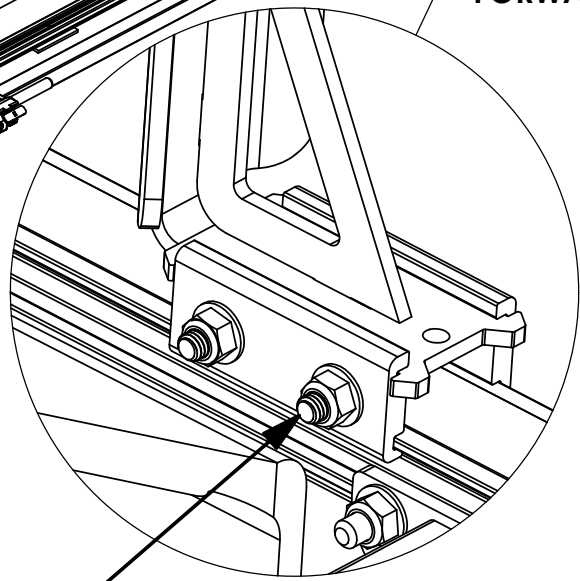

**Step 3: With 1/2" Socket loosen nuts (x2) slide clamp so that it is snug against outside of ladder
Tighten nuts (X2)**

Once all brackets are adjusted operate rack to make sure clamps are not too tight

INSTR. NUMBER	PG:	REV:	ITEM NO.	PART NUMBER	DESCRIPTION	PLMDPSLT	PLMDDSLT
: 70119	1	B	1/15	70106-W	PROLIFT,LMT,DR ASM,PS,R,W	1	-
			2/16	68031-W	DROP DOWN FRONT ARM ASSM PS, WHITE	1	-
PART NUMBER : PLMDPSLT & PLMDDSLT			3	68037-B	CLAMP PAD, 6.5", BLACK	2	2
PART • PROLIFT,MAX,PS,LT DESC. • & PROLIFT,MAX,DS,LT			3/17	66572-B	DROP DOWN, CS CENTER DRIVELINE, BLK	1	-
			5	66611-B	DROP DOWN, PIVOT HANDLE, BLK	1	1
			6	48265	DAMPER ASSEMBLY	1	1
			7	58239	COMPRESSION DAMPER	1	1
			8	65963-W	STOP CLAMP, WHITE	4	4
			9	68186-W	PROLIFT INNER POST, WHITE	1	1
			10	68196-W	PROLIFT MAX DROP STOP, WHITE	1	1
			11	68628-W	PROLIFT HR DAMPER MOUNT, WHITE	2	2
			12	68180-W	DROP DOWN LATCH BRACKET, WHITE	1	1
			13	25340-0	HANDLE LATCH-STD	1	1
			14	72698-W	PL, 6' DS, OS BAR W/ LATCH CLAMP, WHITE	1	1
			15	70107-W	PROLIFT,LMT,DR ASM,PS,R,W	-	1
			16	68031-W	DROP DOWN FRONT ARM ASSM DS, WHITE	-	1
			17	6563-B	DROP DOWN, CS CENTER DRIVELINE, BLK	-	1

- PART NUMBERS WITH "-W" SUFFIX ARE PAINTED WHITE
- FOR BLACK MOUNTING KITS, REPLACE "-W" PARTS WITH "-B" PARTS

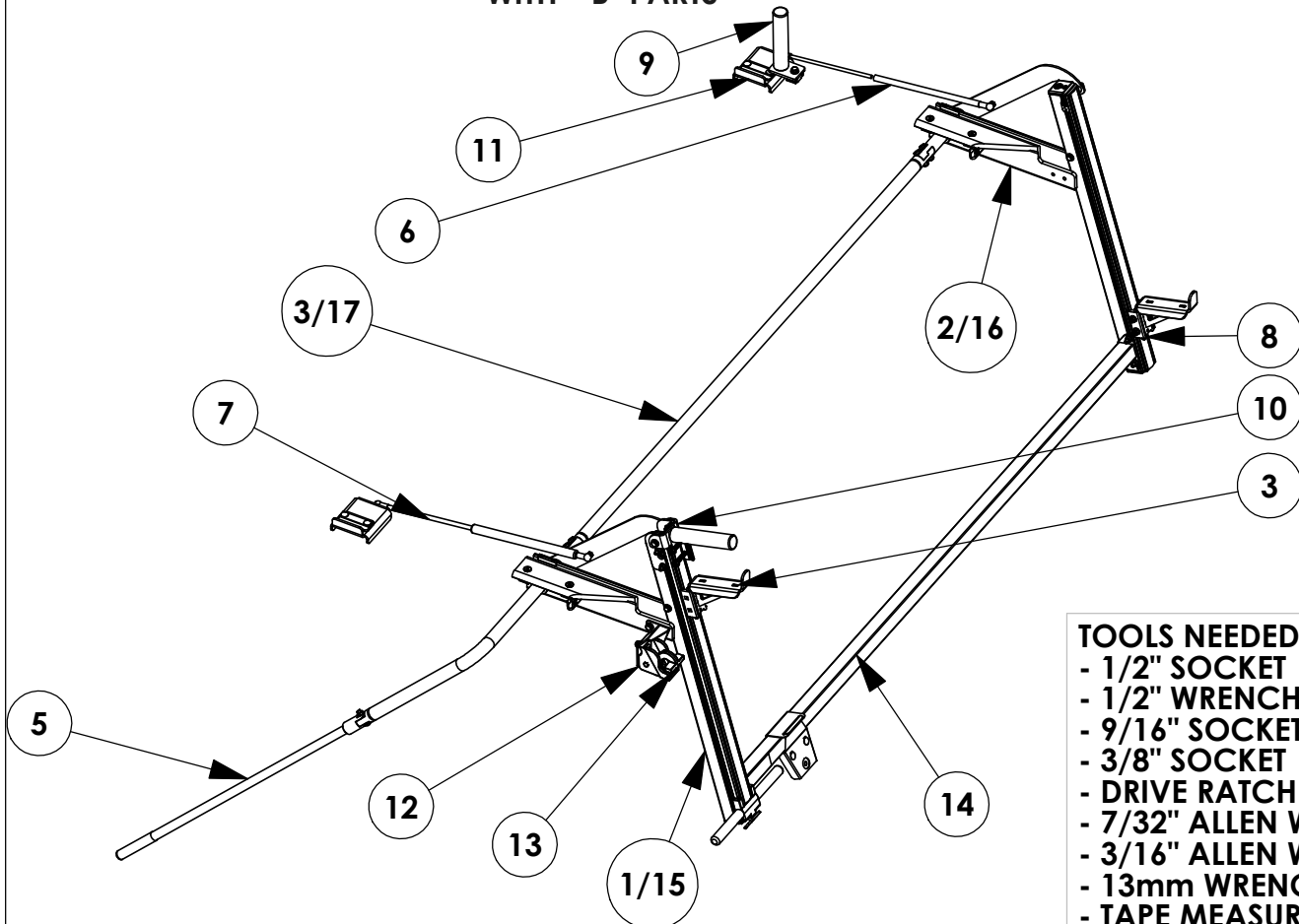

- TOOLS NEEDED:**
- 1/2" SOCKET
 - 1/2" WRENCH
 - 9/16" SOCKET
 - 3/8" SOCKET
 - DRIVE RATCHET
 - 7/32" ALLEN WRENCH
 - 3/16" ALLEN WRENCH
 - 13mm WRENCH
 - TAPE MEASURE
 - RUBBER Mallet
 - IMPACT DRIVER

****IF BUILDING A DUAL SIDED RACK BUILD BOTH SIDES IN PARALLEL FOR EACH STEP. IF BUILDING SINGLE SIDED REFERENCE ONLY THAT SIDE WHEN BUILDING.****

GET TO KNOW THE VEHICLE - AT THE BEGINNING OF ANY INSTALLATION, CHECK THE LOCATION OF THE FUEL TANK, FUEL LINES, BRAKE LINES, HIGH VOLTAGE BATTERIES AND WIRING HARNESSSES TO AVOID INJURY OR PROPERTY DAMAGE FROM TOOL CONTACT.

SEAL ALL EXTERIOR HOLES - ALL INSTALLATION HOLES SHOULD BE SEALED WITH BUTYL TAPE OR SILICON TO PREVENT WATER AND EXHAUST GASES FROM ENTERING THE VEHICLE.

CONTROL DRILL DEPTH - TO AVOID DAMAGE TO THE VEHICLE, USE A DRILL STOP OR CLEARED STEP BIT WHEN DRILLING INSTALLATION HOLES.

ALWAYS ADD PRIMER - WHEN ADDING INSTALLATION HOLES BE SURE TO USE A SELF-ETCHING PRIMER TO PREVENT CORROSION, FASTENER FAILURE AND INJURY.

MOUNTING POINTS MUST HAVE METAL-TO-METAL CONTACT - USE PROVIDED MOUNTING SPACERS TO ACCOMMODATE FOR VEHICLE FEATURES, CARPET OR SUBFLOORS.

PROVIDE CLEARANCE FOR SPACERS - IF THE INSTALLATION VEHICLE CONTAINS A CARPET OR SUBFLOOR, USE A 1-3/16" DIAMETER CARPET CUTTER (P/N: 31183-0) AT ALL MOUNTING LOCATIONS TO OPEN UP ROOM FOR SPACERS.

CHECK SPACER ORIENTATION - BE SURE THAT THE INDENT IN THE SPACER COVERS THE PLUSNUT HEAD; THIS ENSURES THE MOST METAL-TO-METAL CONTACT AND REDUCES VIBRATION.

PLUSNUT INSTALLATION - A PLUSNUT GUN IS RECOMMENDED FOR PLUSNUT INSTALLATION FOR ITS PRODUCTION SPEED. HOWEVER, A PLUSNUT SETTING TOOL CAN ALSO BE USED (P/N: 22200-0).

THRU-BOLT CLEARANCE - WHEN USING A THRU-BOLT AT ANY MOUNTING LOCATION, BE SURE THAT YOUR HOLE HAS 1/16" CLEARANCE.

FASTENERS AND HARDWARE USED

BAG REFERENCE: BAG6820 & BAG72688

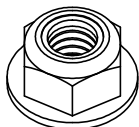

FAS0861
NUT,HEX NLK FLG 5/16-18
QTY: 20



FAS0399
NUT,HEX NLK LT 3/8-16
QTY: 02

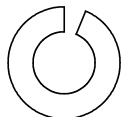

FAS0588
WASHER,LCK SPLIT 5/16
QTY: 02

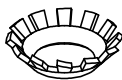

FAS0857
WASHER,LCK EXT CS 5/16
QTY: 04

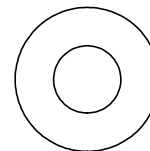

FAS0552
WASHER,FLAT USS 5/16
QTY: 07

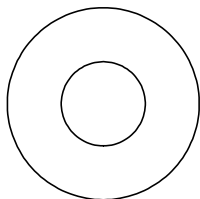

FAS0720
WASHER,FLAT USS 3/8
QTY: 01

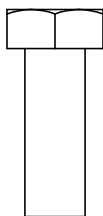

FAS0283
SCREW,HH 5/16-18X.875
QTY: 03



FAS0035
BOLT,SQ HD 5/16-18X1.0
QTY: 02

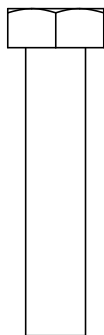

FAS0242
SCREW,HH 5/16-18X1.5
QTY: 04

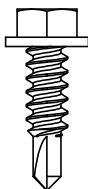

FAS0473
SCREW,HH TEK #12X.75
QTY: 04

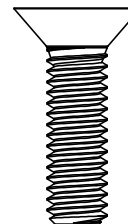

FAS0856
SCREW,FHH 5/16-18X1.13
QTY: 04

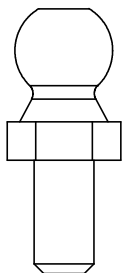

34927-0
BALL STUD 13MM X 5/16-18
QTY: 02

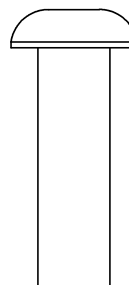

FAS0820
SCREW,BHCS 3/8-16X1.00
QTY: 01

INTENTIONALLY LEFT BLANK

FASTENERS AND HARDWARE USED

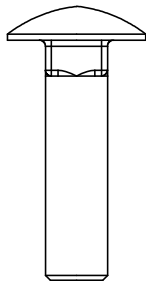

FAS0812
BOLT,CRG 5/16-18X1.25
QTY: 04

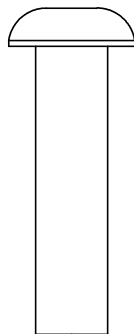

FAS0819
SCREW,BHCS 3/8-16X1.5
QTY: 01

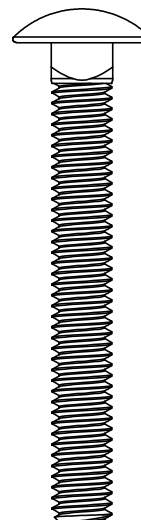

FAS0838
BOLT,CRG 5/16-18X2.5
QTY: 04



64831
REAR ROLLER, SPACER
QTY: 02

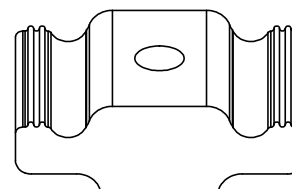

63490
RAIL SLIDE, 1"
QTY: 05

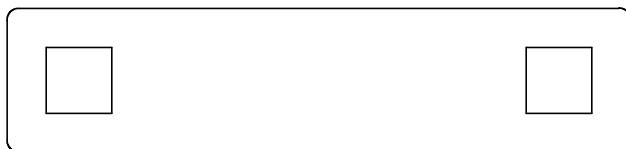

64830
REAR ROLLER, BOLT PLATE
QTY: 02



34928-0
CLIP, SPRING, RETAINER, 13MM
QTY: 04

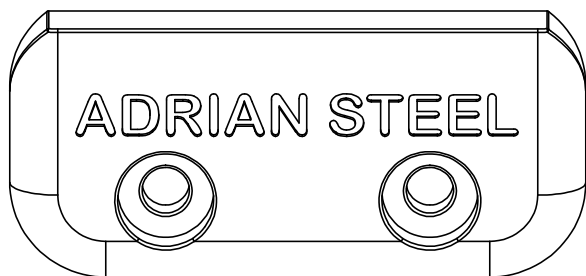

65961
DROP DOWN END CAP
QTY: 02

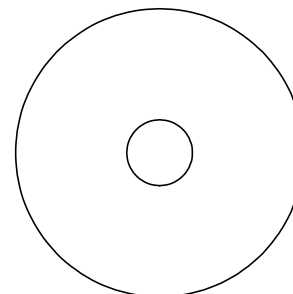

DISCARD FAS0603
SCREW,HH 5/16-18X.875
QTY: 01

INTENTIONALLY LEFT BLANK

STEP 1 - MOUNT DAMPER BRACKETS

A.2

Step 1.1
FULLY TIGHTEN
 34927-0 & FAS0861
 (02 PLACES PER
 SIDE)
 13mm WRENCH
 1/2" SOCKET

STEP 1.2
FULLY TIGHTEN
 (02) FAS0812,
 64830, 64831, &
 (02) FAS0861
 (02 PLACES PER
 SIDE)
 1/2" SOCKET

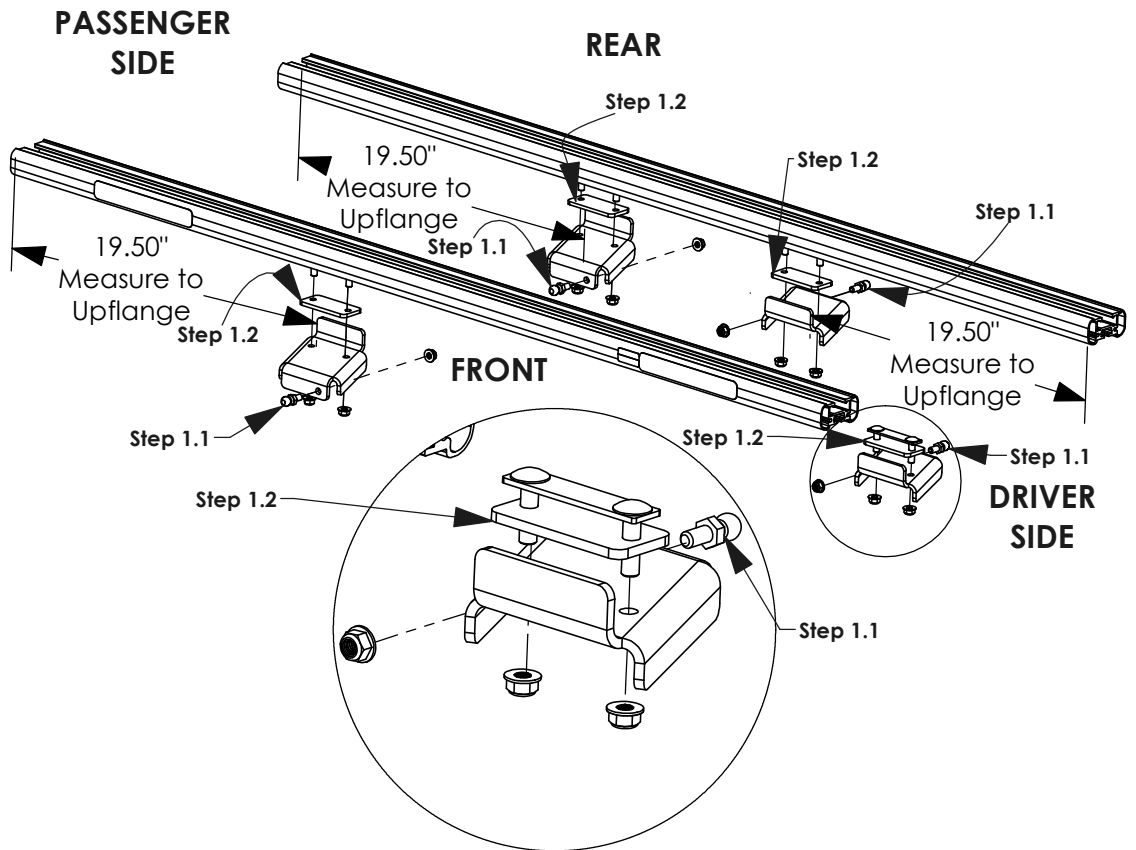

STEP 2 - MOUNT INNER STOPS TO FRONT CROSSBOW

B.1

STEP 2.1
FULLY TIGHTEN
 FAS0283, FAS0552,
 & FAS0588, 63490
 (01 PLACE PER
 SIDE)
 1/2" SOCKET

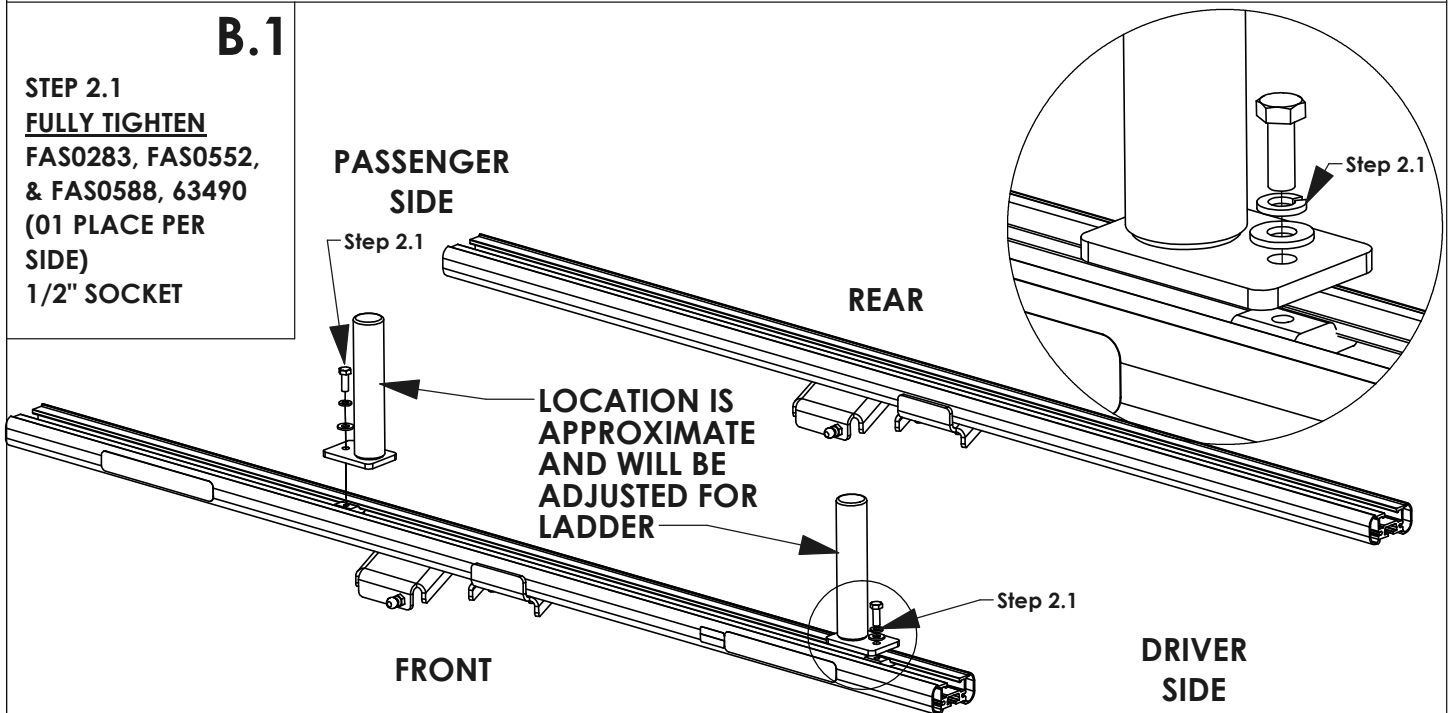

STEP 3 - INSTALL CLAMPS AND HARDWARE ON DROP DOWN CARTRIDGES

REAR SUB-ASSEMBLY

STEP 3.1
FULLY TIGHTEN
 FAS0283, FAS0552,
 & FAS0861
 (02 PLACES)
 1/2" WRENCH
 1/2" SOCKET

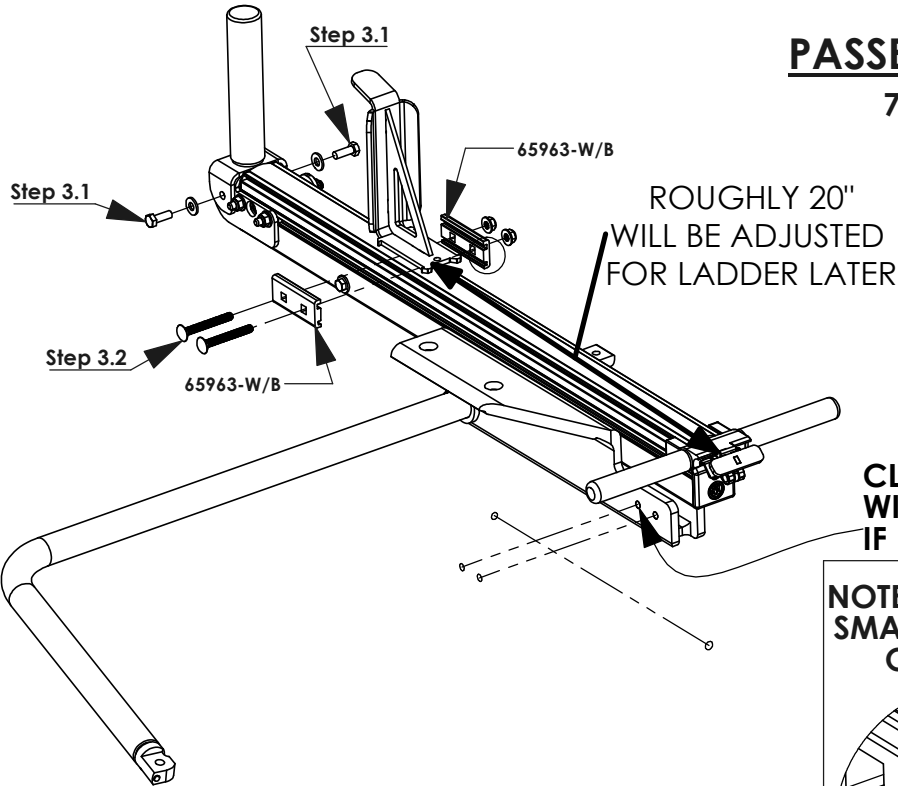

PASSENGER SIDE

70106-W/B

NOTE ORIENTATION:
SMALLER CHANNEL ON BOTTOM

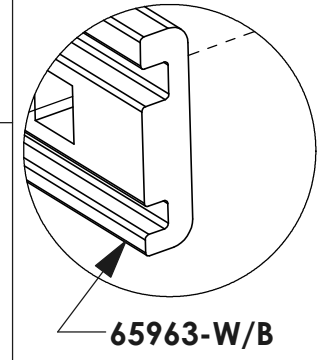

DRIVER SIDE

70107-W/B

STEP 3.2
FULLY TIGHTEN
 FAS0838 &
 FAS0861
 (02 PLACES)
 1/2" SOCKET

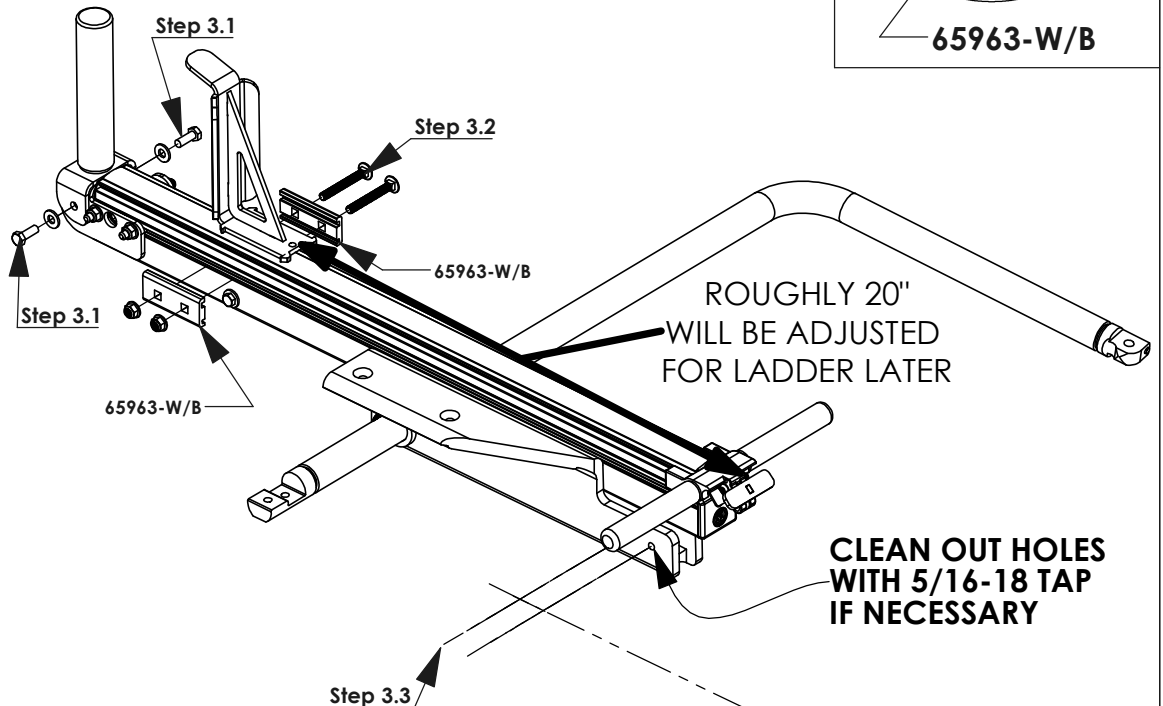

FRONT SUB-ASSEMBLY

PASSENGER SIDE

68031-W/B

STEP 3.3
FULLY TIGHTEN
FAS0838 &
FAS0861
(02 PLACES)
1/2" SOCKET

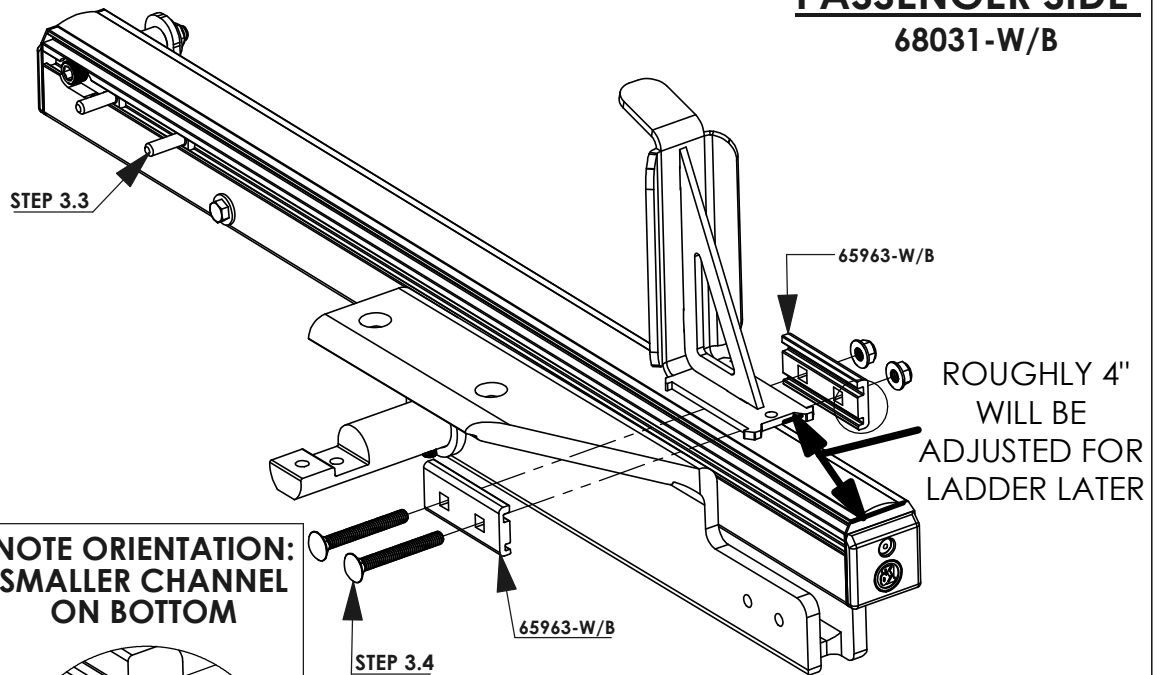

NOTE ORIENTATION:
SMALLER CHANNEL
ON BOTTOM

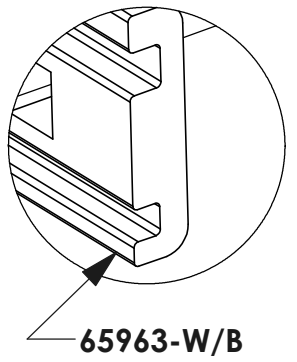

65963-W/B

DRIVER SIDE

68013-W/B

STEP 3.4
FAS0035
SLIDE INTO SLOT
(02 PLACES)

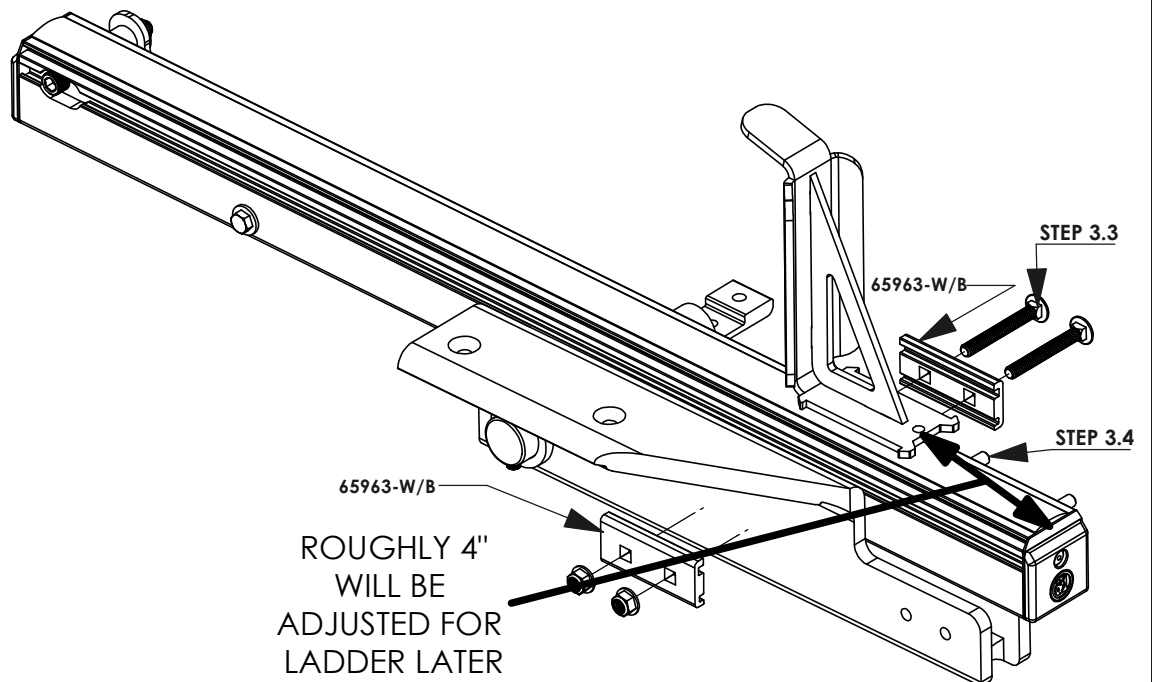

ROUGHLY 4"
WILL BE
ADJUSTED FOR
LADDER LATER



REFERENCE INSTALLATION GUIDE 68895 TABLES 1-3 INSTALLATION OF A.1, A.2, B.1, & B.2 SHOULD BE COMPLETE BEFORE PROCEEDING TO STEP 4

STEP 4 - INSTALL CARTRIDGES ON CROSSBOWS

STEP 4.1
SLIDE 63490 INTO
END OF
CROSSBOWS

C.1

STEP 4.2
LINE UP CORNERS
WITH END OF
CROSSBOW

STEP 4.3
FULLY TIGHTEN
(02) FAS0856,
(02) FAS0857, &
(02) 63490
(02 PLACES PER
SIDE)
3/16" ALLEN

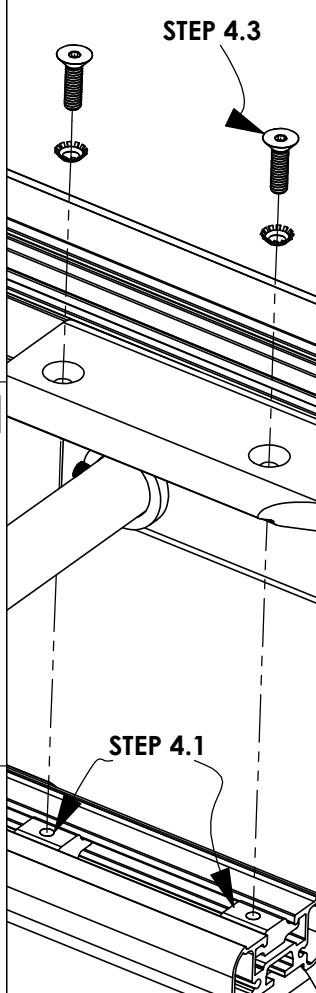

STEP 4.2

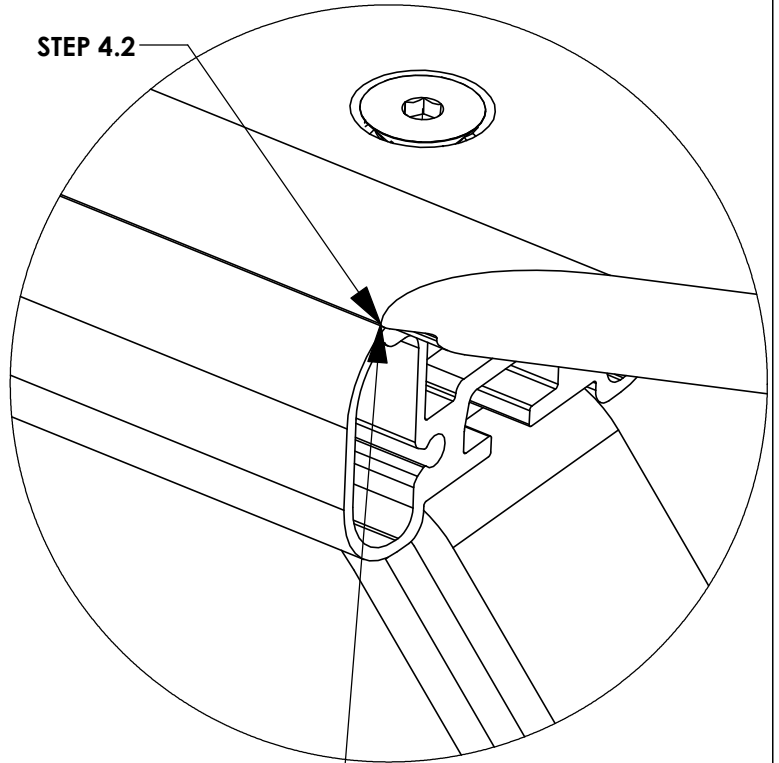

LINE UP CORNERS!!

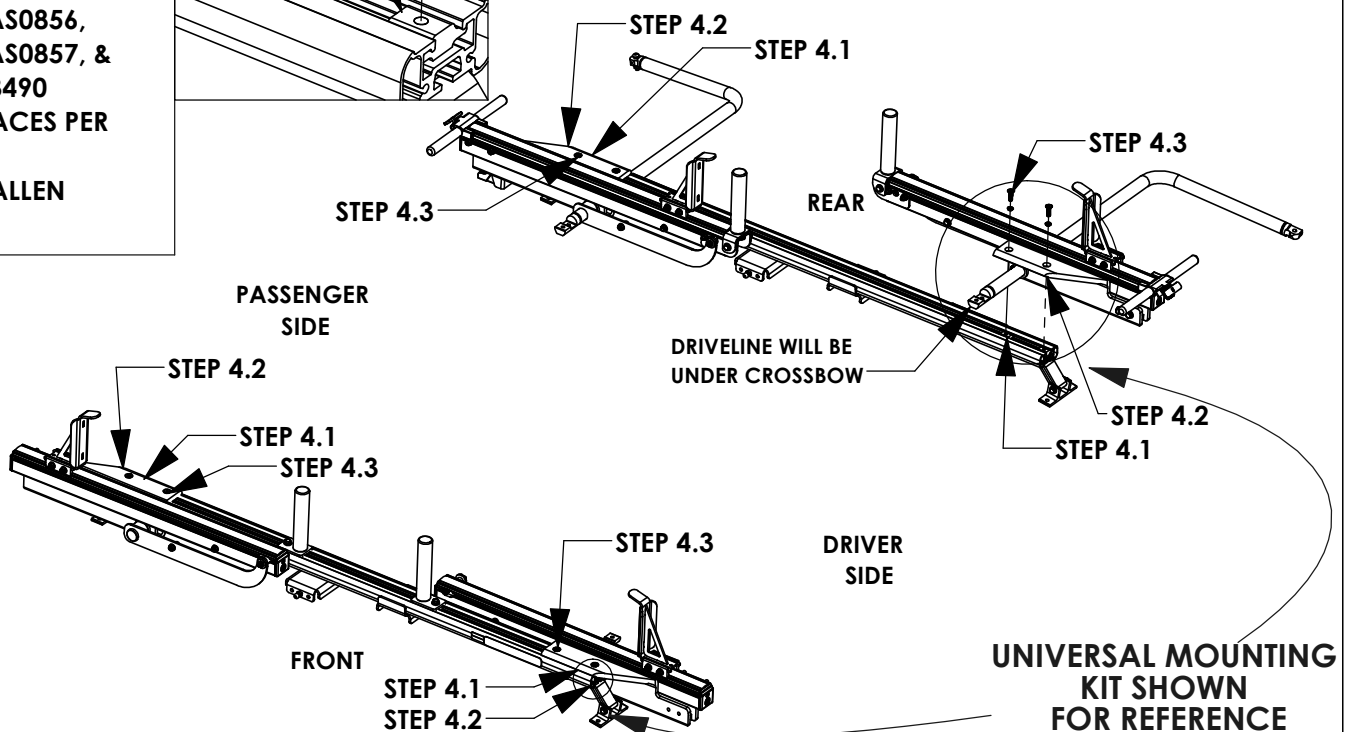

STEP 5 - INSTALL DRIVELINE

STEP 5.1
FULLY TIGHTEN
FAS0242, FAS0552
& FAS0861
(04 PLACES PER
SIDE)
1/2" WRENCH
1/2" SOCKET

BEST PRACTICE:
WHEN INSTALLING
BOLTS OPEN RACK
ROUGHLY 45
DEGREES FOR
EASIER ACCESS &
INSTALLATION

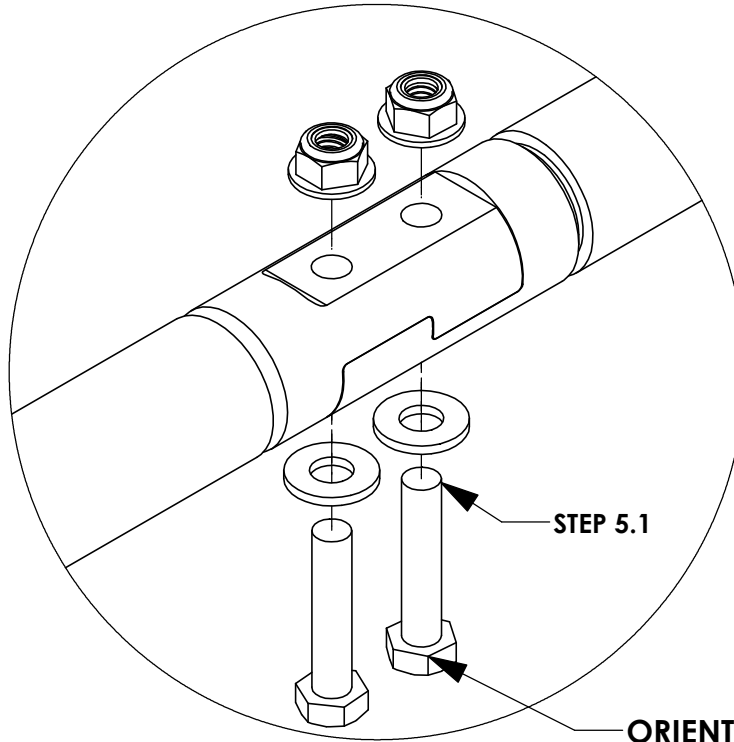

ORIENTATION OF BOLTS IS UPWARDS FOR ASSEMBLY

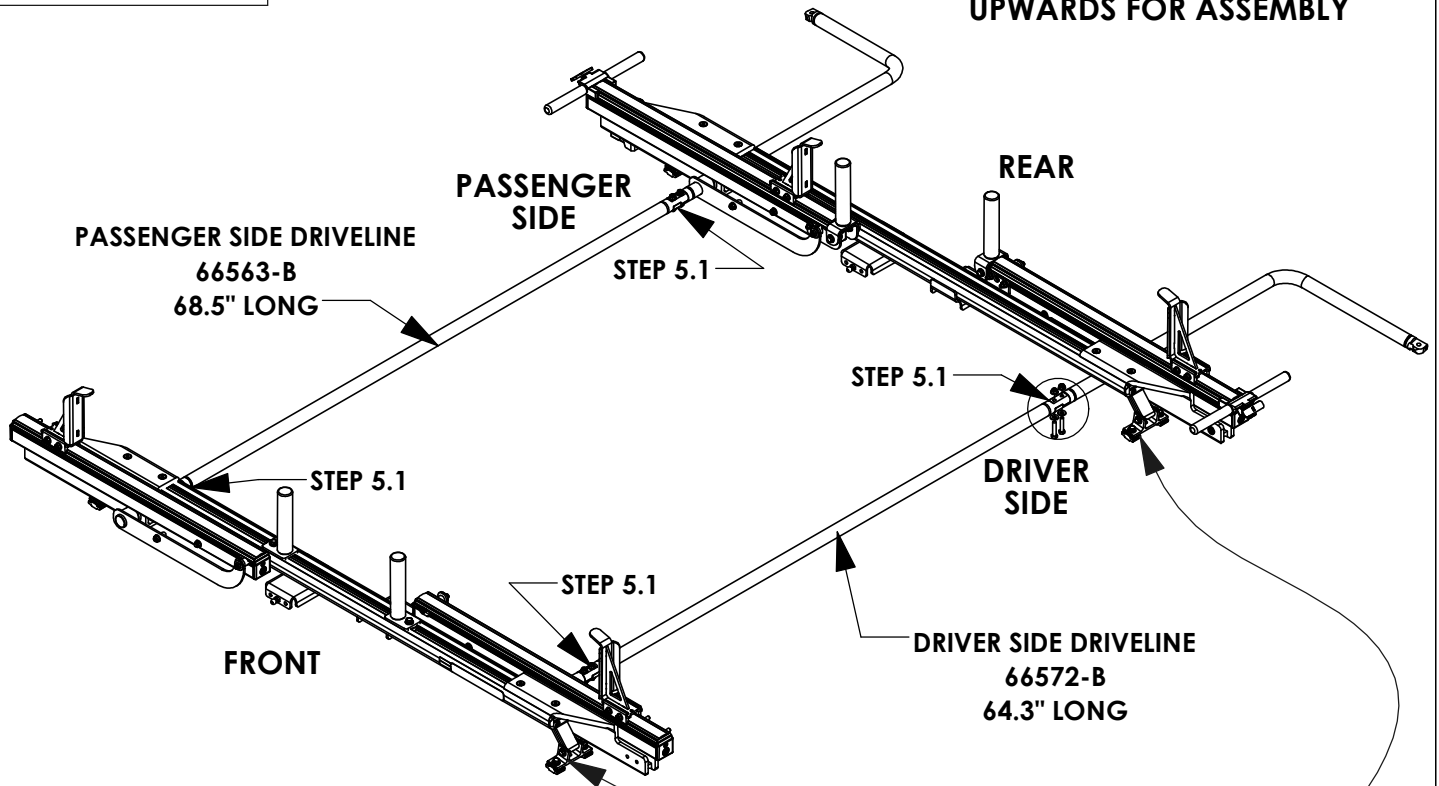

UNIVERSAL MOUNTING
KIT SHOWN
FOR REFERENCE

STEP 6 - DEPLOY RACK & INSTALL DAMPERS AND DROP DOWN HANDLE

Step 6.1
 ATTACH EXTENSION DAMPERS (48625) TO BALL STUDS.
ORIENTATION OF DAMPER MATTERS!!!
 (01 PLACE PER SIDE)

Step 6.2
 ATTACH COMPRESSION DAMPERS (58239) TO BALL STUDS.
ORIENTATION OF DAMPER MATTERS!!!
 (01 PLACE PER SIDE)

Step 6.3
 INSERT LOCKING PINS (34928-0) AFTER MOUNTING DAMPERS TO BALL STUDS
 (04 PLACES PER SIDE)

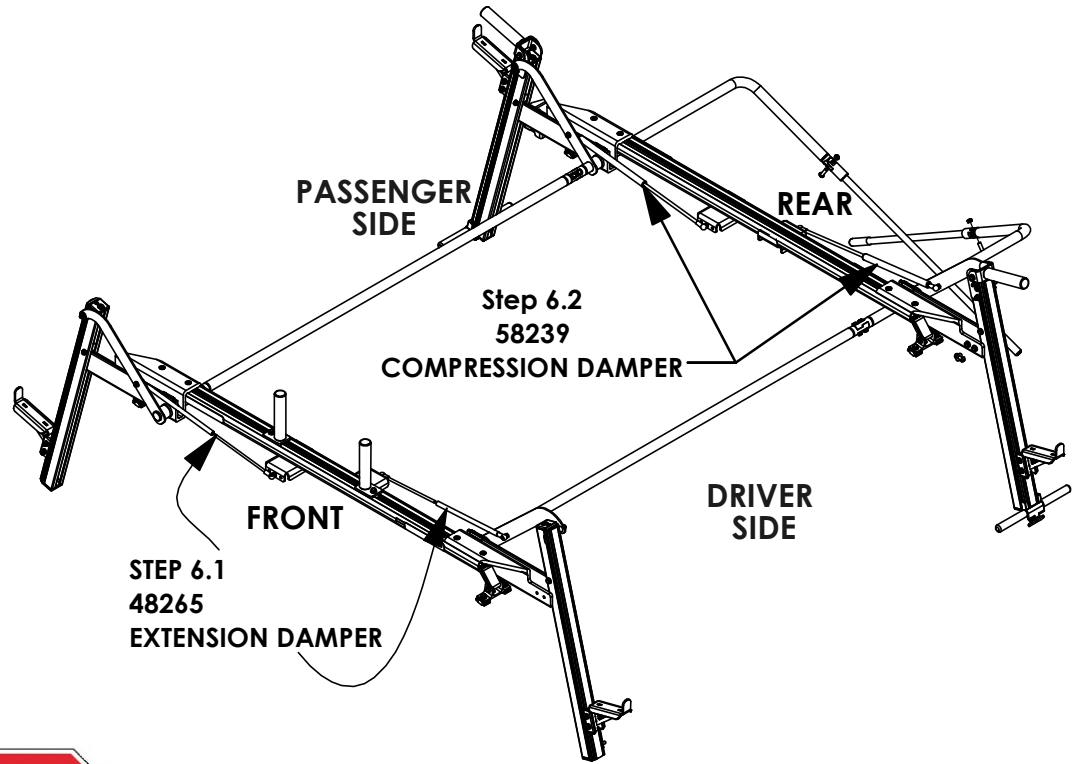

ORIENTATION OF DAMPER MATTERS!!!!

LARGE CYLINDER OF DAMPER ATTACHES TO ARM
 SMALL ROD END ATTACHES TO DAMPER BRACKET

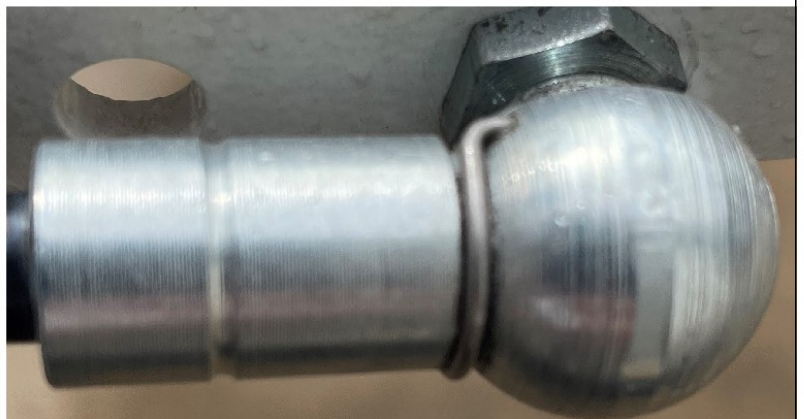
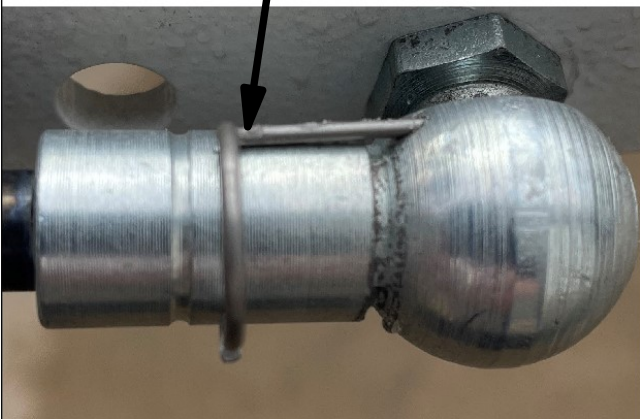
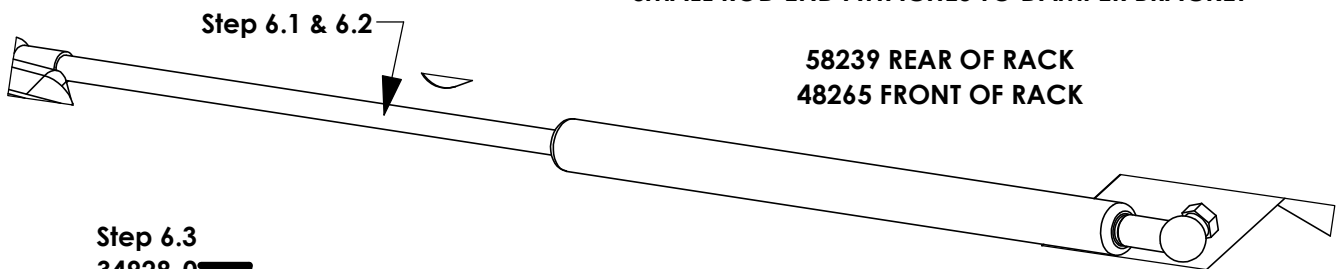

STEP 7 - WHILE RACK DEPLOYED INSTALL O.S. BAR

Step 7.1
FULLY TIGHTEN
FAS0861
(04 PLACES PER
SIDE)
1/2" SOCKET

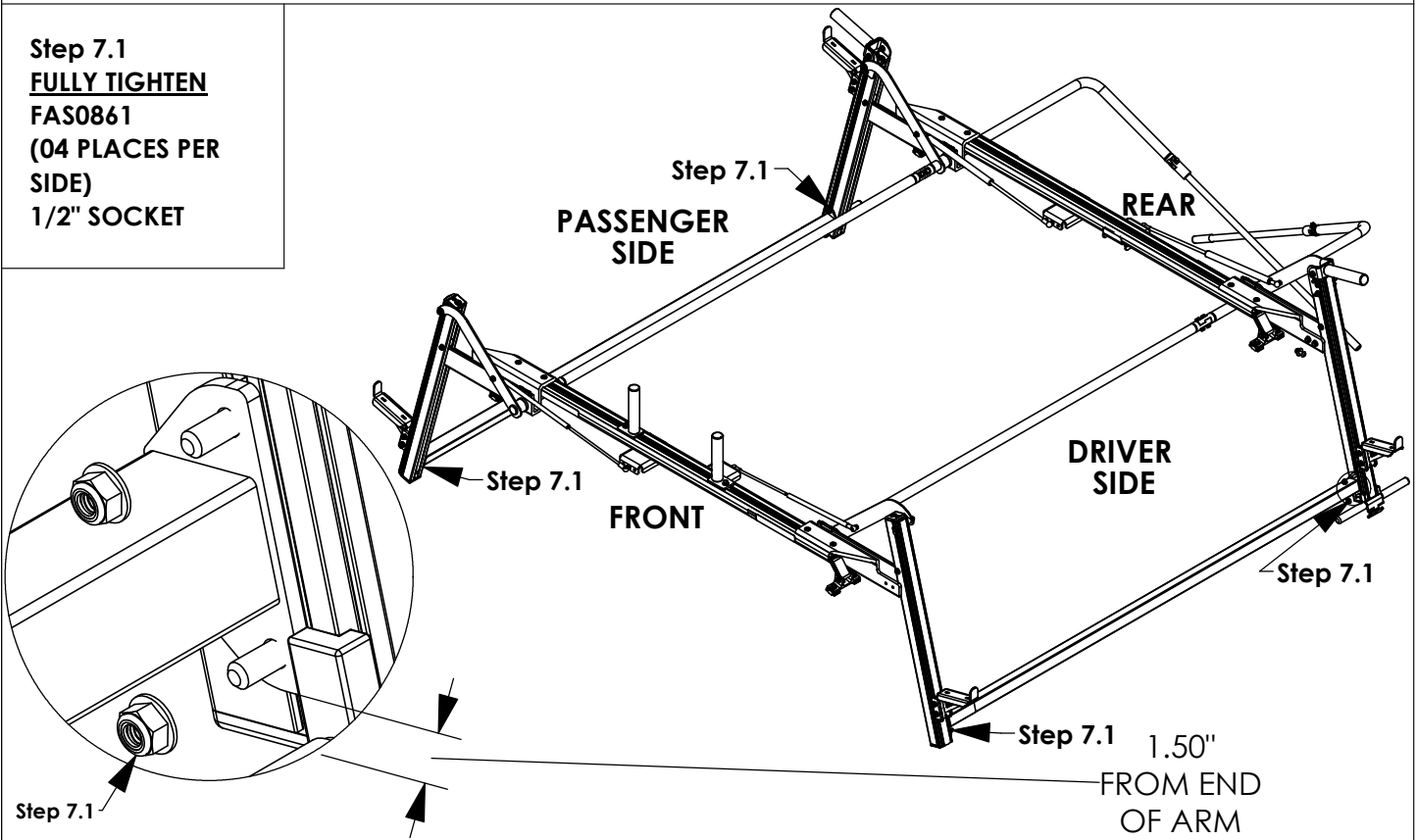

STEP 8 - INSTALL DROP DOWN HANDLE

Step 8.1
FULLY TIGHTEN
FAS0819 & FAS0399
(01 PLACES PER
SIDE)
7/32" ALLEN
9/16" SOCKET

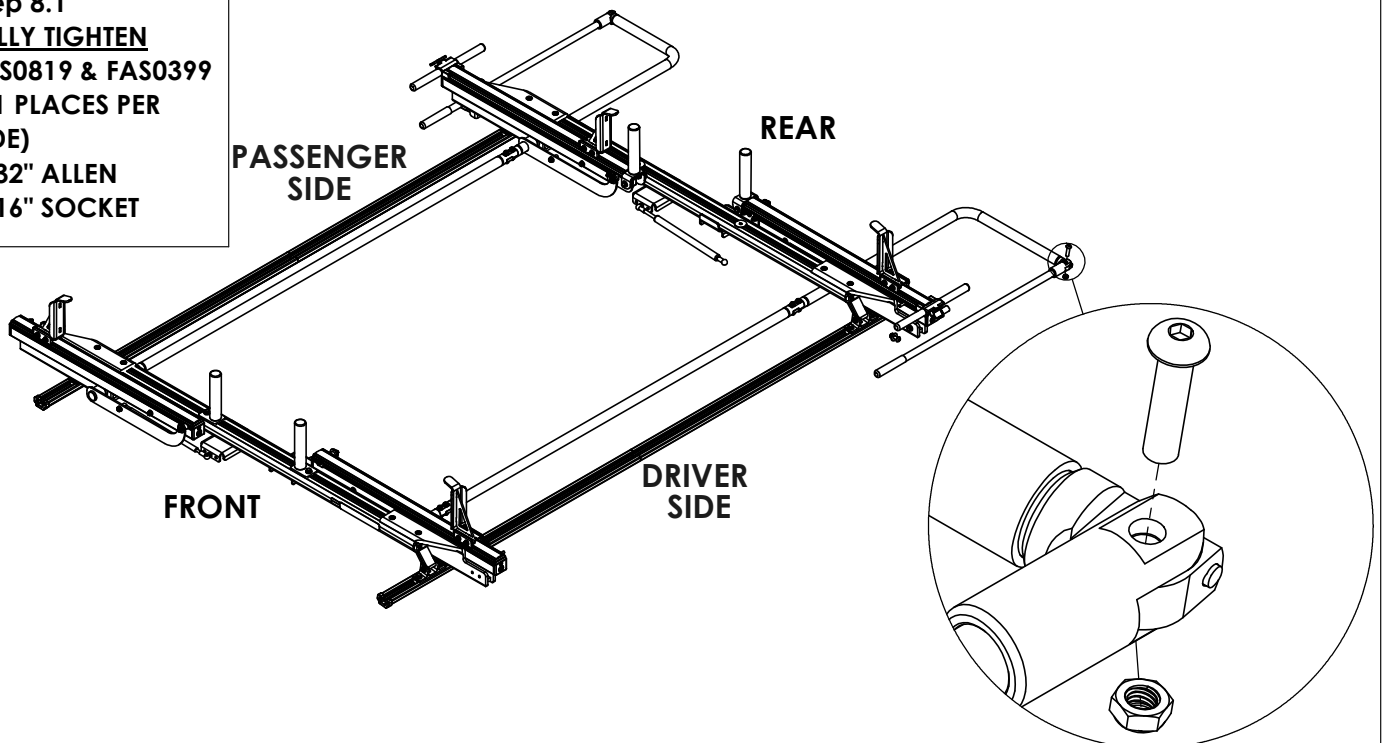

STEP 9 - INSTALL CROSSBOW END CAPS

Step 9.1
FULLY TIGHTEN
(02) FAS0473, 65961
(02 PLACES PER SIDE)
3/8" SOCKET

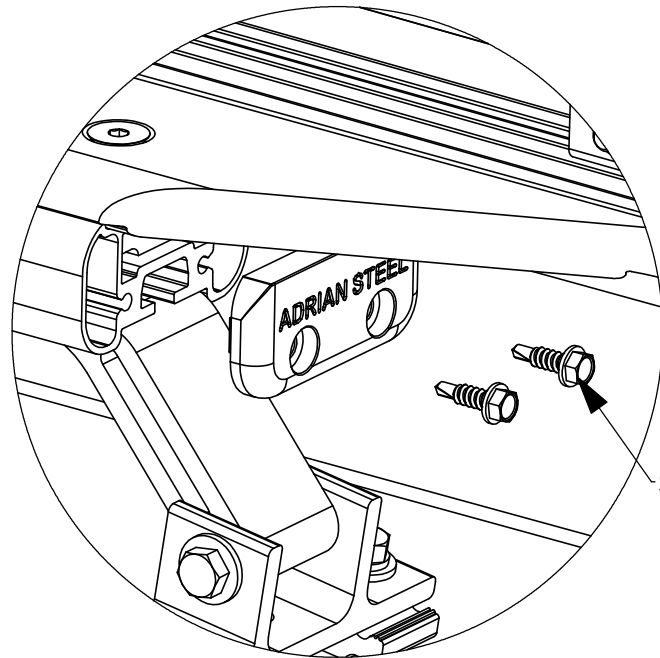

Step 9.1

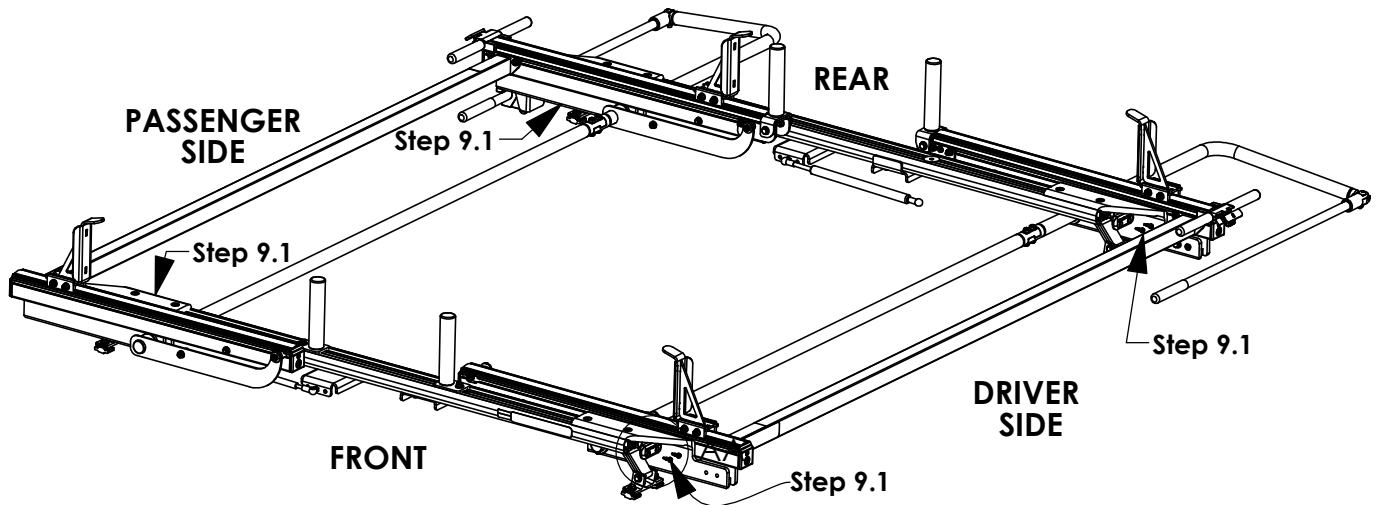

PASSENGER
SIDE

REAR

DRIVER
SIDE

FRONT

STEP 10 - INSTALL HANDLE LATCH

STEP 10.1
FULLY TIGHTEN
FAS0819, FAS0399,
(01 PLACE)
7/32" ALLEN
9/16" SOCKET

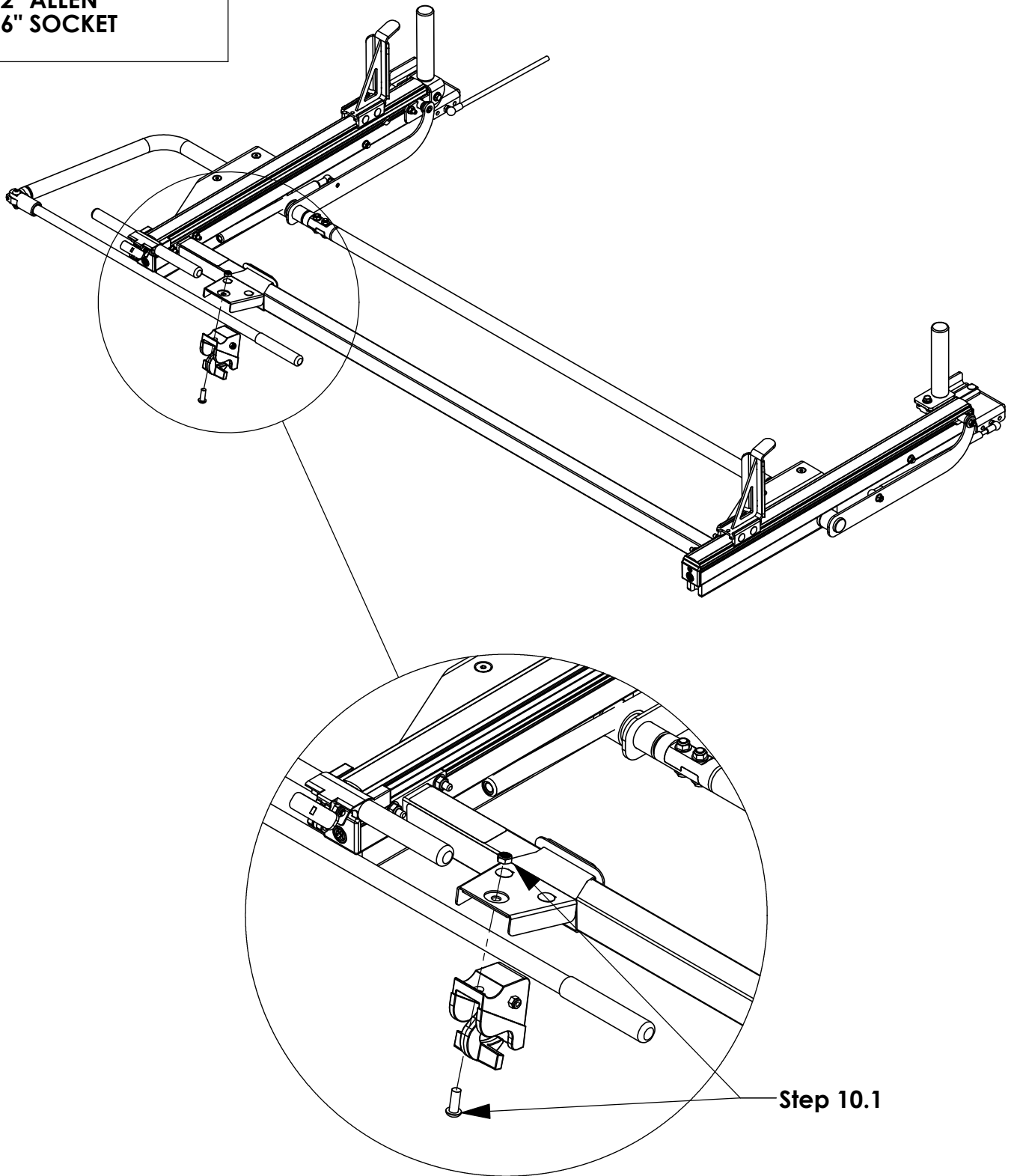

MAKE SURE ALL FASTENERS ARE TIGHTENED!!! INSTALLATION IS COMPLETE

**ADRIAN STEEL®**

Cargo Management Solutions for Commercial Vehicles

PROLIFT MAX DROP 4' PASSENGERS SIDE LOW TOPPER LADDER RACKS

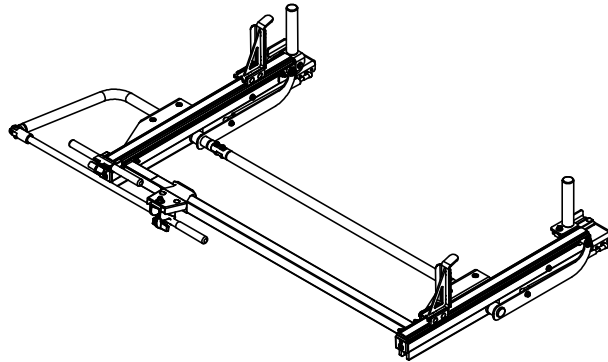
PRODUCT WEIGHT**63.5 LBS****WIDTH X DEPTH X HEIGHT****82.00" X 32.00" X4.00"****CAPACITY****SINGLE LADDER****COLOR****WHITE/BLACK****CATALOG NUMBER****PLMDPSLT4W, PLMDPSLT4B****PRODUCT FEATURES**

ProLift™ Max Drop LOW Topper racks can be used on ADRIAN STEEL BIFF, LEER, UNICOVER and ARE truck toppers with bed lengths from 4'6" - 6'1" with appropriate rail kit, crossbow kit and mounting bracket kit. Use rail kits, crossbow kits, and mounting bracket kits listed in the table below to create new rack combinations. These racks include an attached handle.

The Max-Drop ProLift™ has a single function that lowers the ladder to a single set height and a secondary function that lowers the rear of the ladder even further to a safer more ergonomic height. Most similar to our previous DDLR drop-down series.

Unicover Toppers will use roof rail kits ending in UC (Ex. 4'6" Unicvoer topper would use RRKTOP55UC)

Ignore the roof rail kit when ordering racks for ASC BIFF toppers as they ship with pre-installed rails.

Commercial Part Numbers

Vehicle Platform	Bed Length	Bed Length (in)	Roof Rail Kit	Crossbow kit	Mounting Bracket Kit	Pro-Lift (Passenger Side)	Pro-Lift (Drivers Side)
Maverick	4'6"	54"	RRKTOP55/UC	2BARTOPW	MAVRMBK4W	PLSDPSLT4	PLSDDSLT4
All	4'10" - 5'6"	58" - 66"	RRKTOP58/UC	2BARTOPW	URMBK4W	PLSDPSLT4	PLSDDSLT4
All	5'7" - 6'1"	67"-73"	RRKTOP67/UC	2BARTOPW	URMBK4W	PLSDPSLT4	PLSDDSLT4

NOTE:CROSSBAR KIT IS DIFFERENT FOR COMBO WITH GRIPLOCK. IN THIS CASE,USE 2BAR53W/B

SEE PAGE 2 FOR APPLICATION NOTES, ACCESSORIES AND OTHER PRODUCTS THAT WORK WITH THIS UNIT.



PROLIFT MAX DROP 4' PASSENGERS SIDE LOW TOPPER LADDER RACKS

CATALOG NUMBER**PLMDPSLT4W, PLMDPSLT4B****PRODUCT APPLICATION**

TOPPER PROLIFT LADDER RACKS ARE FOR USE ON PICKUP TRUCK BED TOPPERS, AVAILABLE IN 4 FT, 5 FT, AND 6 FT LENGTHS FOR ALL DIFFERENT SIZE TRUCK BEDS.

Reduce back and shoulder injuries while loading/unloading ladders by eliminating the need to climb on bumpers and tires to reach the cargo on the roof of your vehicle.

The ProLift™ uses unique, patent-pending, mechanical advantages, and high-performing spring assist struts to raise and lower ladders with an almost effortless pull.

ACCESSORIES THAT WILL WORK WITH THIS PRODUCT

CATALOG NUMBER	DESCRIPTION (smart)
RRKTOP55	ROOF RAIL KIT, TOPPER, 55"
RRKTOP58	ROOF RAIL KIT, TOPPER, 58"
RRKTOP67	ROOF RAIL KIT, TOPPER, 67"
RRKTOP55UC	ROOF RAIL KIT, TOPPER, 55" UC
RRKTOP58UC	ROOF RAIL KIT, TOPPER, 58" UC
RRKTOP67UC	ROOF RAIL KIT, TOPPER, 67" UC
2BARTOPW / B	2BAR UTILITY RACK, TOP
2BAR53W / B	2BAR, CROSSBOW, 53"
URMBK4W / B	UTILITY, MNT BKT KT, RAIL
PLMDDSLT4W/B	PROLIFT, MAX, DS, LOW TOP, 4
GL-TOPDSW / B	GRIP-LOCK, TOP DS

The information contained in this document is the sole property of ADRIAN STEEL COMPANY. ADRIAN STEEL COMPANY retains the right to modify and/or change the product of its design at any time with prior notification.



Mounting Bracket Kit, 4-Pack, White, Multiple Pickups

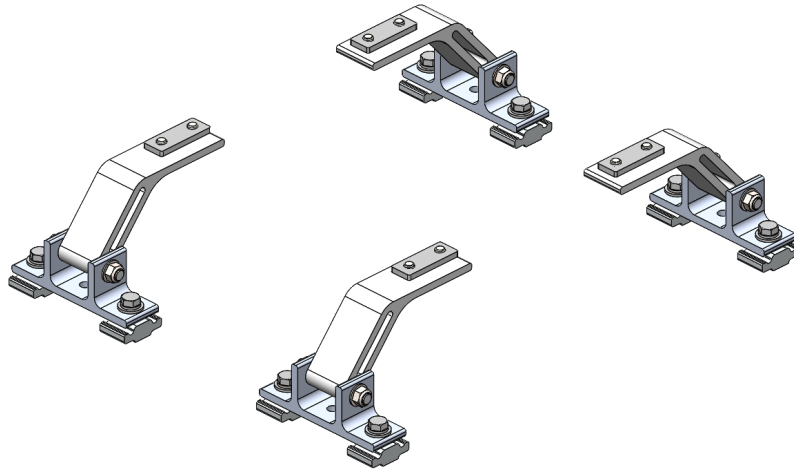

PRODUCT WEIGHT
4.0 LBS

HEIGHT OFF ROOF
SEE TABLE BELOW

CAPACITY
**REFER TO OEM'S
RECOMMENDED LOAD
RATING**
COLOR

WHITE

CATALOG NUMBER

URMBK4W

PRODUCT FEATURES

Aluminum mounting bracket kit for the PROFILE™ HD Utility, Grip-Lock, and/or ProLift ladder racks. Only works with the OEM specific, Adrian Steel supplied roof rail kit.

Utility and Grip-Lock racks are not recommended for medium or high roof vehicles!

Reference respective OEM specific roof rail kit for more detailed list of compatible accessories.

SEE PAGE 2 FOR APPLICATION NOTES AND ACCESSORIES, OTHER PRODUCTS THAT WORK WITH THIS UNIT.

PAGE 1 of 2

The information contained in this document is the sole property of ADRIAN STEEL COMPANY. ADRIAN STEEL COMPANY retains the right to modify and/or change the product of its design at any time without prior notification.



CATALOG NUMBER URMBK4W

PRODUCT APPLICATION

This product is designed to work with OEM specific rail kit for HD Utility, Grip-Lock, and/or ProLift racks. HD Utility and Grip-Lock racks are not recommended for medium or high roof vehicles!

ACCESSORIES THAT WILL WORK WITH THIS PRODUCT

CATALOG NUMBER	DESCRIPTION	CATALOG NUMBER	DESCRIPTION
RRKFT	Mounting Roof Rail Kit, Transit	RRKNVFSV	Mounting Roof Rail Kit, NV
RRKSP	Mounting Roof Rail Kit, Sprinter	RRKPM	Mounting Roof Rail Kit, ProMaster, 118" WB, 159" WB, 159" WB Extended
RRKPM136WB	Mounting Roof Rail Kit, ProMaster, 136" WB	RRKSBTOP	Mounting Roof Rail Kit, Multiple Pickups
RRKLBTOP	Mounting Roof Rail Kit, Multiple Pickups		

Reference respective OEM specific roof rail kit for more detailed list of compatible accessories.

INSTR. NUMBER : 66850	PG: 1	REV: D	ITEM NO.	PART NUMBER	DESCRIPTION	URMBK4W	URMBK2W
	PART NUMBER : URMBK		1	65123-W	UTILITY, FT MOUNT ARM, ST, W	4	2
PART DESC. : UTILITY, MNT BKT KT, RAIL			2	63852-W	UTILITY, MOUNTING BRKT, W	4	2

**-PART NUMBERS WITH "-W" SUFFIX ARE PAINTED WHITE
-FOR BLACK MOUNTING KITS, REPLACE "-W" PARTS WITH "-B" PARTS**

NOTE: THIS INSTRUCTION IS VALID FOR THE FOLLOWING KITS:

- URMBK4W
- URMBK4B
- URMBK2W
- URMBK2B

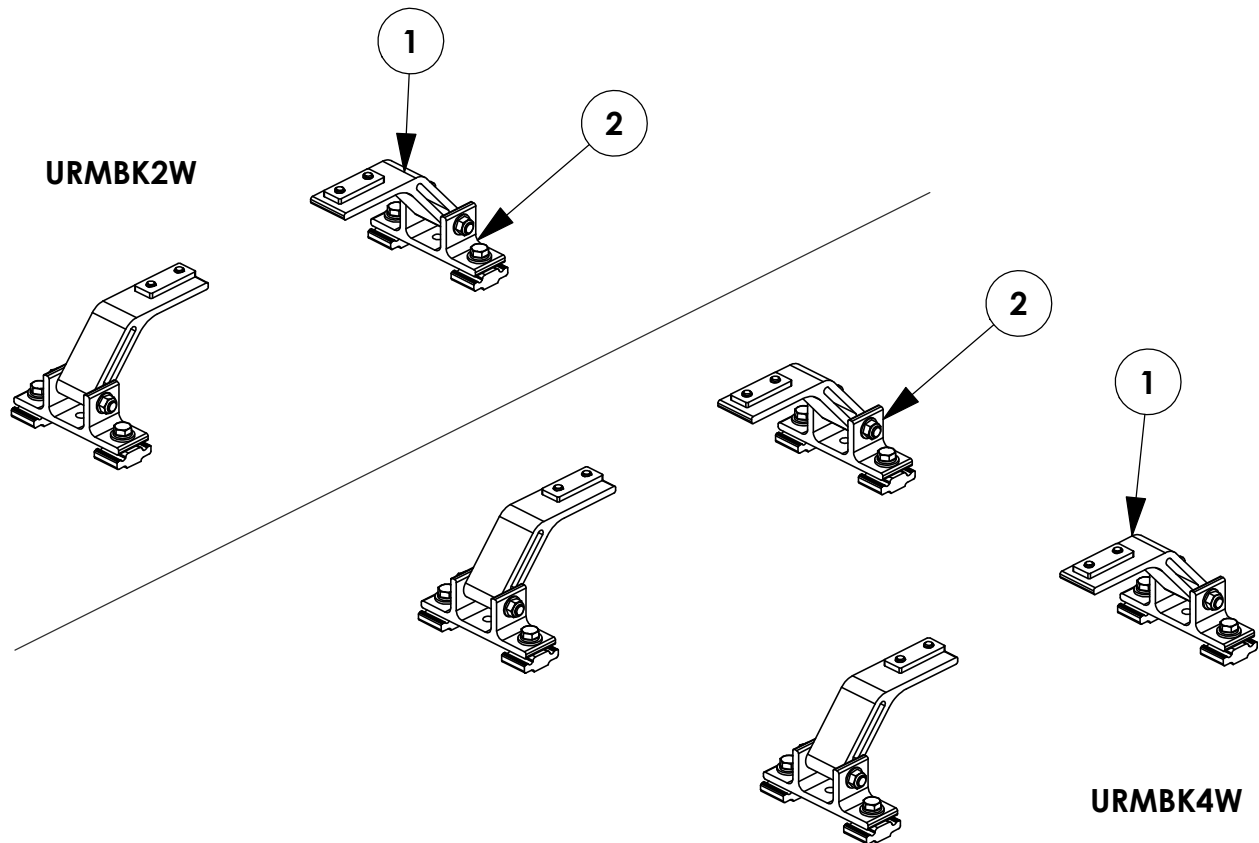

TOOLS NEEDED:

- DRIVE RATCHET
- IMPACT DRIVER
- 3/16" SOCKET
- 1/2" SOCKET
- 1/2" WRENCH
- TAPE MEASURE

GET TO KNOW THE VEHICLE - AT THE BEGINNING OF ANY INSTALLATION, CHECK THE LOCATION OF THE FUEL TANK, FUEL LINES, BRAKE LINES, HIGH VOLTAGE BATTERIES AND WIRING HARNESSSES TO AVOID INJURY OR PROPERTY DAMAGE FROM TOOL CONTACT.

SEAL ALL EXTERIOR HOLES - ALL INSTALLATION HOLES SHOULD BE SEALED WITH BUTYL TAPE OR SILICON TO PREVENT WATER AND EXHAUST GASES FROM ENTERING THE VEHICLE.

CONTROL DRILL DEPTH - TO AVOID DAMAGE TO THE VEHICLE, USE A DRILL STOP OR CLEARED STEP BIT WHEN DRILLING INSTALLATION HOLES.

ALWAYS ADD PRIMER - WHEN ADDING INSTALLATION HOLES BE SURE TO USE A SELF-ETCHING PRIMER TO PREVENT CORROSION, FASTENER FAILURE AND INJURY.

MOUNTING POINTS MUST HAVE METAL-TO-METAL CONTACT - USE PROVIDED MOUNTING SPACERS TO ACCOMMODATE FOR VEHICLE FEATURES, CARPET OR SUBFLOORS.

PROVIDE CLEARANCE FOR SPACERS - IF THE INSTALLATION VEHICLE CONTAINS A CARPET OR SUBFLOOR, USE A 1-3/16" DIAMETER CARPET CUTTER (P/N: 31183-0) AT ALL MOUNTING LOCATIONS TO OPEN UP ROOM FOR SPACERS.

CHECK SPACER ORIENTATION - BE SURE THAT THE INDENT IN THE SPACER COVERS THE PLUSNUT HEAD; THIS ENSURES THE MOST METAL-TO-METAL CONTACT AND REDUCES VIBRATION.

PLUSNUT INSTALLATION - A PLUSNUT GUN IS RECOMMENDED FOR PLUSNUT INSTALLATION FOR ITS PRODUCTION SPEED. HOWEVER, A PLUSNUT SETTING TOOL CAN ALSO BE USED (P/N: 22200-0).

THRU-BOLT CLEARANCE - WHEN USING A THRU-BOLT AT ANY MOUNTING LOCATION, BE SURE THAT YOUR HOLE HAS 1/16" CLEARANCE.

FASTENERS AND HARDWARE USED

BAG REFERENCE: BAG66848

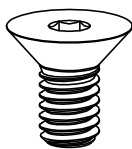

FAS0858
5/16-18X.63
FHH SCREW
QTY: 8

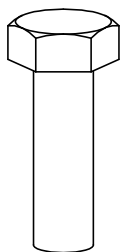

FAS0597
5/16-18X1.0 SS
HH SCREW
QTY: 8

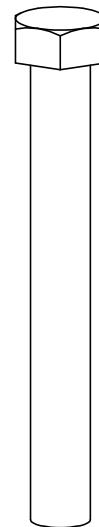

FAS0243
5/16-18X2.5 SS
HH SCREW
QTY: 4



FAS0857
5/16 SS WASHER,
LOCK EXT CS
QTY: 8



FAS0588
5/16 SS
SPLIT WASHER
QTY: 8



FAS0552
5/16 SS
FLAT WASHER
QTY: 12

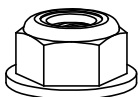

FAS0861
5/16-18 SS
HH FLG NUT
QTY: 4

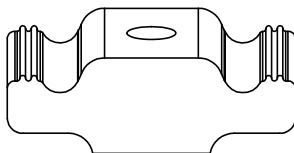

63490
RAIL SLIDE,
1"
QTY: 8

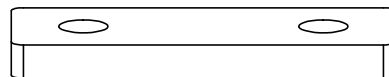

68042
PROFILE FOOT
MOUNTING PLATE
QTY: 4

PAGE INTENTIONALLY LEFT BLANK

STEP 1 - ASSEMBLE MOUNTING ARMS TO CROSSBOW



CHECK TABLE 1-3 IN INSTRUCTION 68895 FOR ADDITIONAL ACCESSORY SLIDE INSTALLATION BEFORE INSTALLING MOUNTING BRACKETS (ALL A.2 ITEMS SHOULD BE COMPLETELY ASSEMBLED FIRST!)

STEP 1.1
LOOSELY ASSEMBLE
UNTIL AFTER STEP 3
(2) FAS0857, (2)
FAS0858, 68042

(02 PLACES PER
CROSSBOW)
3/16" ALLEN

ATTENTION!

IF INSTALLING A GRIP-LOCK ON A PICKUP TRUCK TOPPER, ASSEMBLE MOUNTING ARMS FACING OUTWARD FOR THAT SIDE OF THE RACK

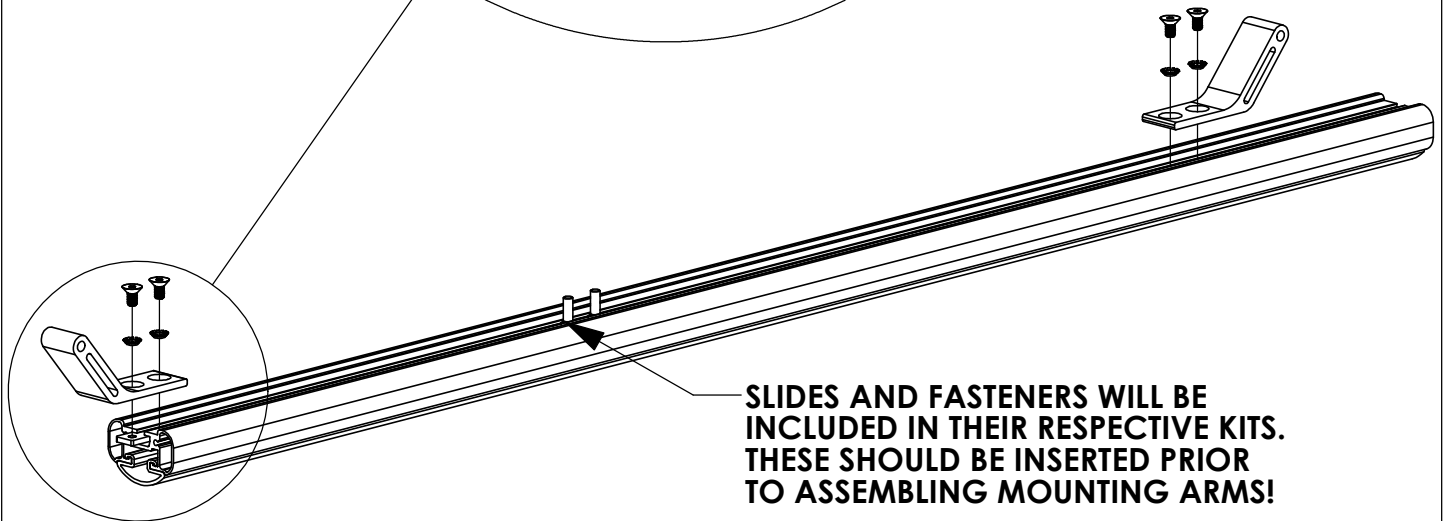
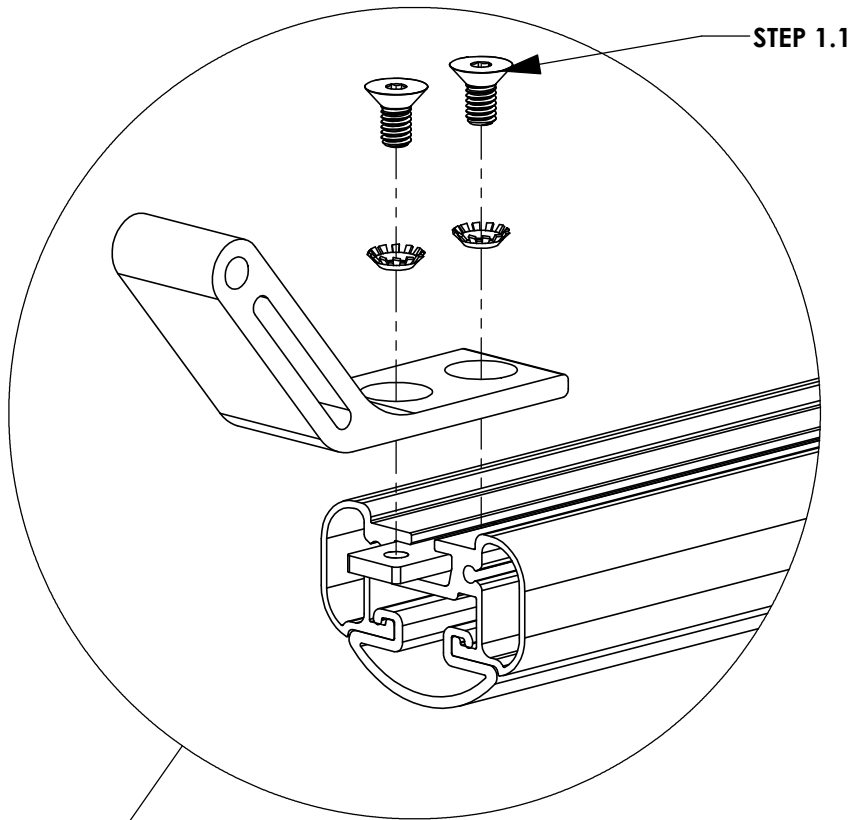

STEP 2 - SECURE CROSSBOW

FULL SIZE VANS

CENTER CROSSBOW ON MOUNTING BRACKETS

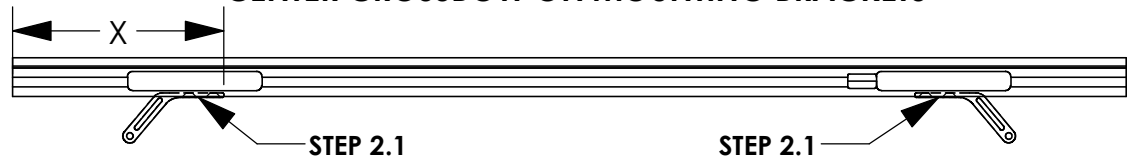

STEP 2.1
FULLY TIGHTEN
FROM STEP 1.1

 (04 PLACES PER
 CROSSBOW)
 3/16" ALLEN

VEHICLE PLATFORM	DIMENSION "X" (in.) - 58" CROSSBOW	DIMENSION "X" (in.) - 68" CROSSBOW
FORD TRANSIT	6 5/8"	11 5/8"
RAM PROMASTER	6"	11"
NISSAN NV	4 7/8"	9 7/8"
MERCEDES SPRINTER (LOW ROOF)	4 5/8"	9 5/8"
MERCEDES SPRINTER (HIGH ROOF)	8 1/8"	13 1/8"

DIMENSION WILL VARY BASED ON ROOF RAIL PLACEMENT ON TOPPER

PICKUP TRUCK TOPPERS

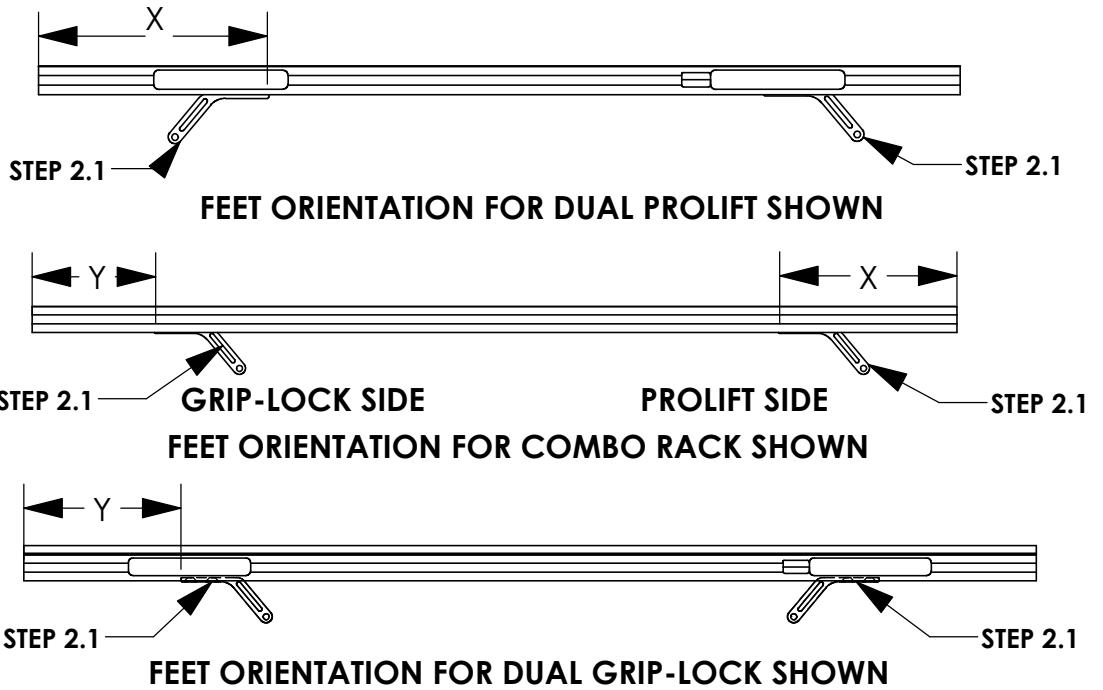

MOUNTING FEET FOR GRIP LOCK SIDE OF COMBO RACK WILL FACE OUTWARD FROM ROOF CENTERLINE ON TOPPER

CROSSBOW LENGTH	DIMENSION "X" (in.) - PROLIFT	DIMENSION "Y" (in.) - GRIPLOCK
48" (PROLIFT)	MINIMUM 10 1/8"	N/A
53" (COMBO)	MINIMUM 10 1/8"	MAX 7 1/8"
58" (GRIP-LOCK)	N/A	MAX 7 1/8"

NOTE - THESE DIMENSIONS ARE APPROXIMATE AND WILL VARY SLIGHTLY WITH ANY TOLERANCE IN THE BUILD OF THE VEHICLE

STEP 3 - ASSEMBLE LOWER MOUNTING FOOT TO ROOF RAIL

STEP 3.1
FULLY TIGHTEN
 FAS0597, FAS0552,
 FAS0588, 63490 ON
 REAR MOUNTING FEET

(02 PLACES PER
 MOUNTING FOOT)
 1/2" SOCKET

STEP 3.2
LEAVE LOOSE UNTIL
AFTER STEP 4
 FAS0597, FAS0552,
 FAS0588, 63490 ON
 FRONT MOUNTING
 FEET

(02 PLACES PER
 MOUNTING FOOT)
 1/2" SOCKET

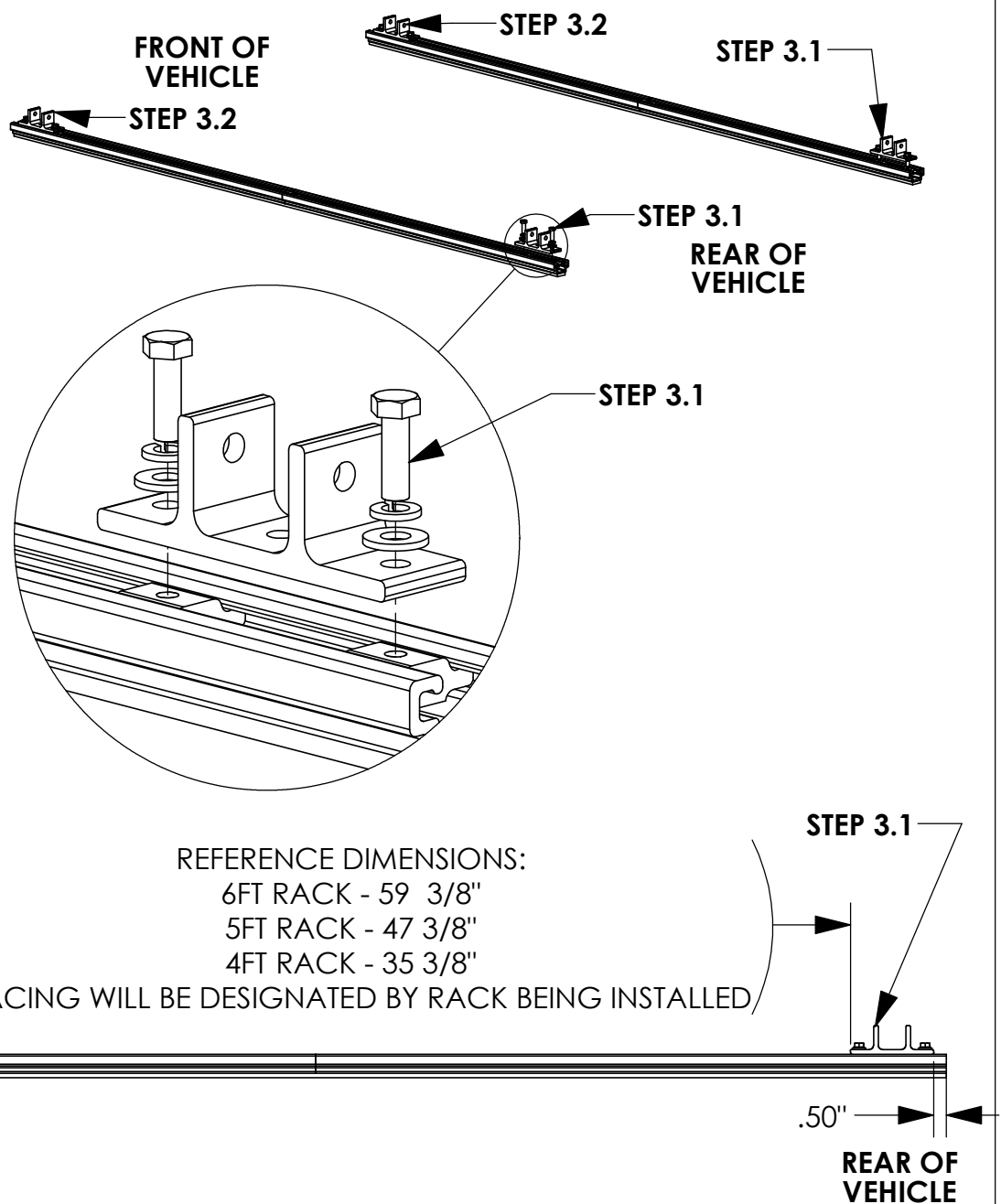

CROSSBOW POSITIONING NOTES:

HD UTILITY RACK -

REAR CROSSBOW - REARWARD AS POSSIBLE
 FRONT CROSSBOW- POSITION TO BEST FIT END USER'S PRODUCT

GRIP LOCK/PROLIFT LADDER RACKS -

1/2" FROM END OF RAIL UNLESS OTHERWISE STATED IN RESPECTIVE
 INSTRUCTION FOR CROSSBOW PLACEMENT.

STEP 4 - ASSEMBLE MOUNTING BRACKETS TO MOUNTING ARMS



BEFORE PROCEEDING WITH THIS STEP FINISH ASSEMBLING ACCESSORIES ONTO RACK. (IE GRIP LOCK, PROLIFT, ETC)

STEP 4.1

FULLY TIGHTEN

FAS0243, FAS0552,
FAS0861

(02 PLACES PER
CROSSBOW)

1/2" SOCKET
1/2" WRENCH

STEP 4.2

FULLY TIGHTEN

FAS0597, FAS0552,
FAS0588, 63490 ON
FRONT MOUNTING
FEET

(02 PLACES PER
MOUNTING FOOT)

1/2" SOCKET

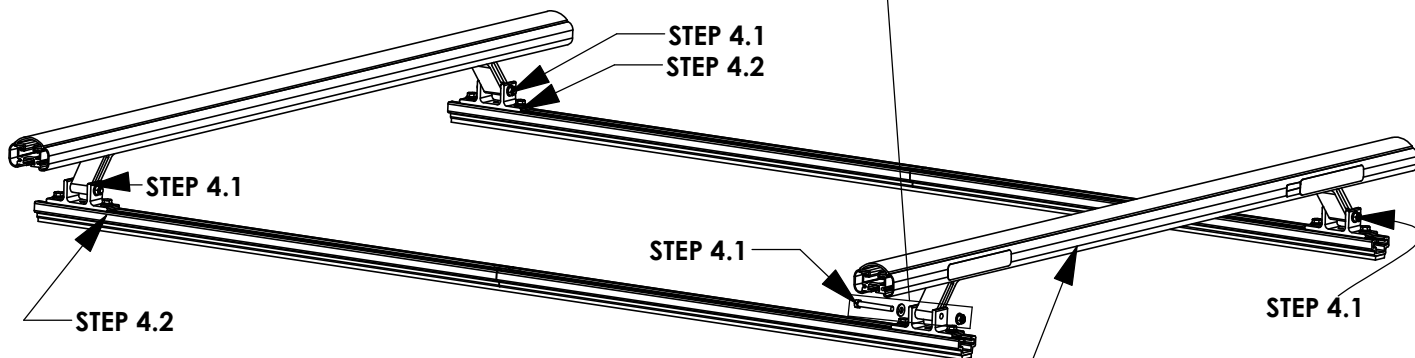
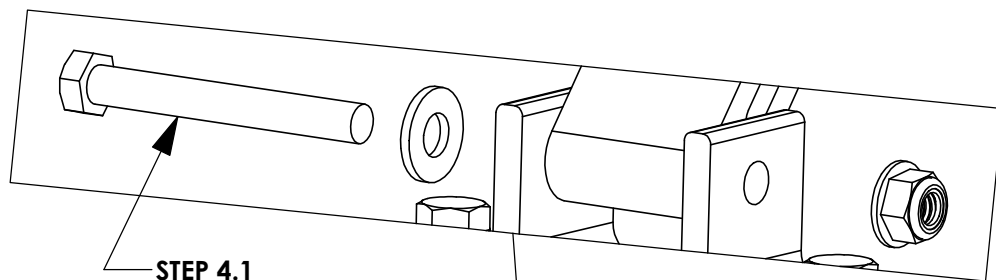

NOTE ORIENTATION OF LABELS ON CROSSBOW

REFERENCE - NO ACCESSORIES SHOWN

STEP 5 - ADJUST MOUNTING BRACKET LOCATION IF NECESSARY

CROSSBOW POSITIONING NOTES:

HD UTILITY RACK -

REAR CROSSBOW - REARWARD AS POSSIBLE
 FRONT CROSSBOW- POSITION TO BEST FIT END USER'S PRODUCT

GRIP LOCK/PROLIFT LADDER RACKS -

1/2" FROM END OF RAIL UNLESS OTHERWISE STATED IN RESPECTIVE INSTRUCTION FOR CROSSBOW PLACEMENT.

6' ARE TOPPER / 8' LEER TOPPER

**△ A OPTIMAL RAIL KIT POSITION:
 TOPPER ROOF RAIL KIT END TO BE
 A-DIM FROM BLACK TOPPER TRIM**

**△ B UTILITY MOUNTING BRACKET:
 REAR MOUNTING BRACKETS WILL BE
 B-DIM FROM THE END OF THE ROOF
 RAIL KIT**

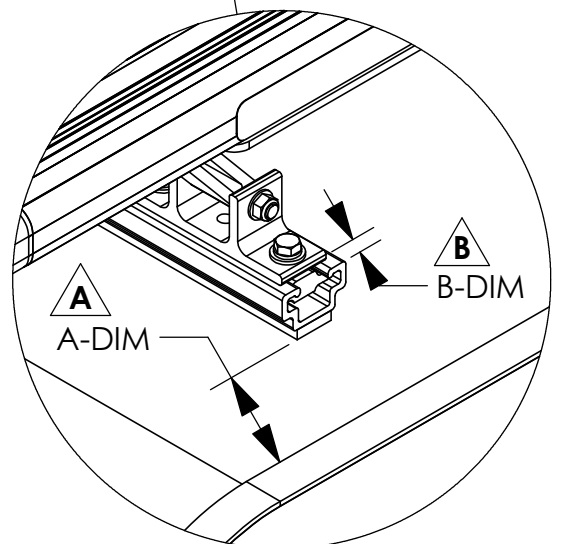
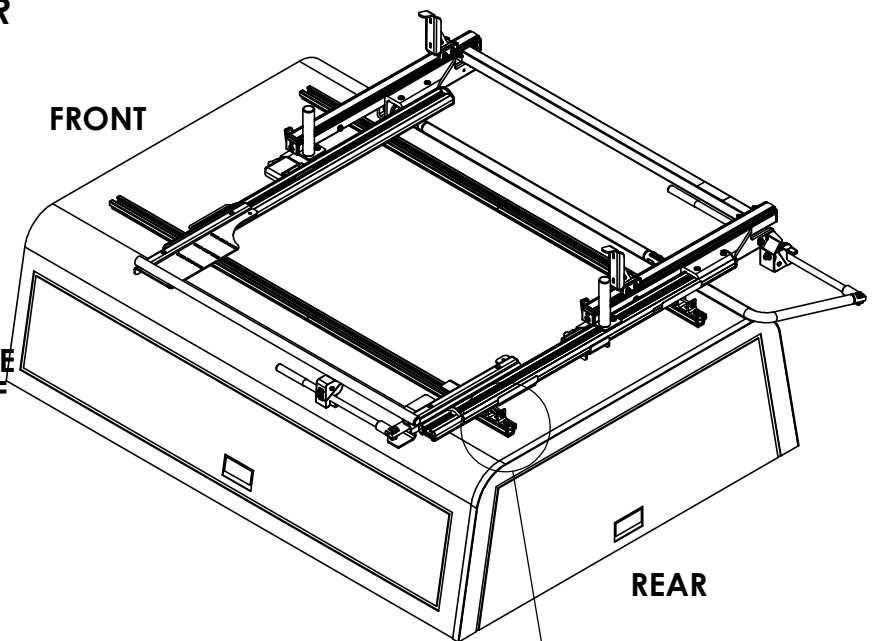

TOPPER/ DIMENSION	6' ARE TOPPER	8' LEER TOPPER
A-DIM	3.00"	1.00"
B-DIM	0.50"	0.50"

**NOTE:
 IF RAILS HAVE BEEN PREVOIUSLY INSTALLED, LOOSEN TOPPER RAIL BRACKET RAIL SLIDES
 AND ADJUST TO MEET DESIRED POSITIONING**

INSTALLATION IS COMPLETE!! MAKE SURE ALL FASTENERS ARE TIGHTENED



2-Crossbar Kit, 48", White, Multiple Pickups



PRODUCT WEIGHT
13.4 LBS

CROSSBOW LENGTH X
HEIGHT

49" x 2"

CAPACITY

**REFER TO OEM'S
RECOMMENDED LOAD
RATING**

COLOR

WHITE

CATALOG NUMBER

2BARTOPW

PRODUCT FEATURES

Aluminum base 2-crossbow kit for PROFILE™ HD Utility, Grip-Lock, ProLift, or combo ladder racks. Works with all ARE and Leer toppers for all cab styles and bed lengths. Works with and without OEM specific rail kit and generic mounting bracket kits.

Additional crossbows and optional uprights, conduit kits, and rear rollers available.

Utility and grip lock ladder racks are not recommended for medium and high roof vehicles!

Please refer to OEM specific mounting kit or rail kit for additional information on compatible accessories.

INSTALLATION GUIDE FOR PROFILE™ SERIES LADDER RACKS

INSTRUCTION #:
68895

REV:
B

THIS INSTRUCTION PROVIDES A GENERAL GUIDE OF INSTALLATION SEQUENCE FOR ALL PROFILE™ SERIES LADDER RACKS. PLEASE ENSURE ALL ACCESSORIES ARE INSTALLED PER TYPE OF RACK BEFORE PROCEEDING TO NEXT PAGE.

REFERENCE THIS INSTRUCTION THROUGHOUT THE ENTIRETY OF YOUR INSTALL TO PREVENT ACCESSORIES BEING INSTALLED INCORRECTLY/OUT OF SEQUENCE!

STEPS 21 - 81 ON PAGE 3 IS THE RECOMMENDED ASSEMBLY SEQUENCE FOR A FULL TABLE ASSEMBLY BEFORE INSTALLING ON THE ROOF OF THE VEHICLE.

STEPS 2R - 8R ON PAGE 4 IS AN ALTERNATE ASSEMBLY SEQUENCE TO INSTALL THE RACK ON THE VEHICLE ROOF AS IT IS BUILT.

PLEASE SELECT THE ASSEMBLY SEQUENCE THAT BEST WORKS FOR YOU!

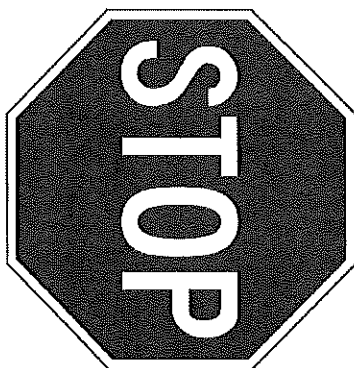

ASSEMBLY STEPS:

STEP 1A. SUB-ASSEMBLE EACH CROSSBOW WITH DESIRED ACCESSORIES FOR SECTIONS A.1 & A.2.

INSTRUCTIONS FOR EACH KIT CAN BE FOUND IN THEIR RESPECTIVE CARTON!

TOP OF CROSSBOW *IMAGE NOT TO SCALE!

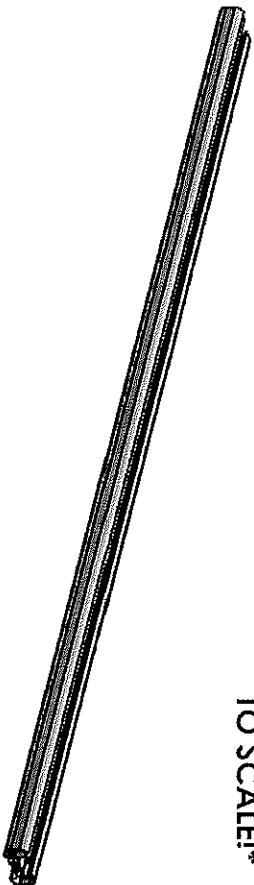

BOTTOM OF CROSSBOW

TABLE 1

TOP OF CROSSBOW		COMPONENTS TO INSTALL
HD UTILITY		- CONDUIT KIT OR BEACON
Grip-Lock		- CONDUIT KIT OR BEACON
ProLift		- CONDUIT KIT OR BEACON
BOTTOM OF CROSSBOW		
COMPONENTS TO INSTALL		
HD UTILITY		- LADDER STOP, STROBE BRACKET, AND/OR REAR ROLLER
Grip-Lock		- Grip-Lock SUB-ASSEMBLY
ProLift		- DAMPER BRACKET

STEP 1B. SUB-ASSEMBLE EACH CROSSBOW WITH DESIRED ACCESSORIES FOR SECTIONS B.1 & B.2. INSTRUCTIONS FOR EACH KIT CAN BE FOUND IN THEIR RESPECTIVE CARTON!

TOP OF CROSSBOW *IMAGE NOT TO SCALE!*

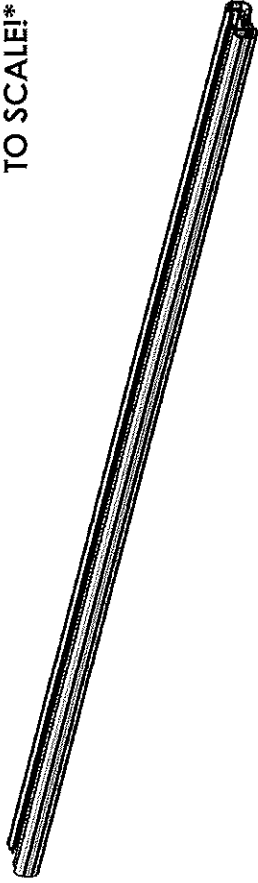

BOTTOM OF CROSSBOW

TABLE 2

TOP OF CROSSBOW	
	COMPONENTS TO INSTALL
HD UTILITY	- WEAR STRIP (MODIFY IF NECESSARY, TABLE 3)
Grip-Lock	- WEAR STRIP (MODIFY IF NECESSARY, TABLE 3)
ProLift	- INNER STOP POST
BOTTOM OF CROSSBOW	
	COMPONENTS TO INSTALL
HD UTILITY	- MOUNTING BRACKETS
Grip-Lock	- MOUNTING BRACKETS
ProLift	- MOUNTING BRACKETS

ALTER WEAR STRIP AND INSTALL ON CROSSBOW (IF APPLICABLE)! REFERENCE TABLE 3 BELOW FOR WEAR STRIP ALTERATION INSTRUCTIONS!

TABLE 3

ADDED ACCESSORIES	ALTERATION FOR WEAR STRIP
4" UPRIGHT***	REMOVE 2" FROM END OF WEAR STRIP
4" PVC CONDUIT KIT	REMOVE 7.25" FROM CENTER OF WEAR STRIP
6" PVC CONDUIT KIT	REMOVE 9.50" FROM CENTER OF WEAR STRIP
ALUMINUM BOX CONDUIT KIT	REMOVE 13.25" FROM CENTER OF WEAR STRIP
BEACON	REMOVE 4" FROM CENTER OF WEAR STRIP
ProLift (SINGLE SIDE)	CUT WEAR STRIP IN HALF, DO NOT INSTALL ON ProLift SIDE
ProLift (DUAL SIDE)	DO NOT INSTALL WEAR STRIP

SLIDE WEAR STRIP INTO RAIL AND CENTER (1 PER CROSSBOW)

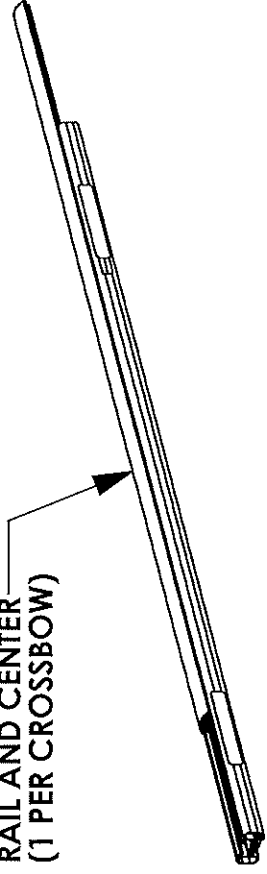

STEP 1C SUB-ASSEMBLE EACH CROSSBOW WITH DESIRED ACCESSORIES FOR SECTIONS C.1 & C.2

TOP OF CROSSBOW
IMAGE NOT TO SCALE!

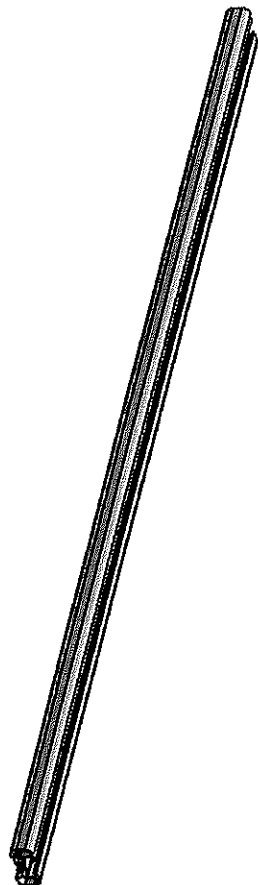

BOTTOM OF CROSSBOW

TABLE 4

TOP OF CROSSBOW COMPONENTS TO INSTALL	
HD UTILITY	- 4" UPRIGHT
Grip-Lock	- N/A
Prolift	- SLIDES FOR BASE EXTRUSION
BOTTOM OF CROSSBOW COMPONENTS TO INSTALL	
HD UTILITY	- UPRIGHTS (6", 9", RATCHET)
Grip-Lock	- STROBES
Prolift	- STROBES

ASSEMBLY STEPS (FULL BENCH ASSEMBLY):

- 2T. ADD DRIVELINES (IF INSTALLING Prolift)
- 3T. ADD HANDLES (IF INSTALLING Grip-Lock OR Prolift) AND DAMPERS (IF INSTALLING Prolift)
- 4T. ADD OUTER SUPPORT BARS (IF INSTALLING Grip-Lock OR Prolift)
- 5T. ADD STEP LADDER KIT (Grip-Lock OR Prolift ONLY)

6T. ASSEMBLE ENDS CAPS TO CROSSBOW

USED FOR HD UTILITY & Grip-Lock RACKS

LOCATED IN CROSSBOW KIT

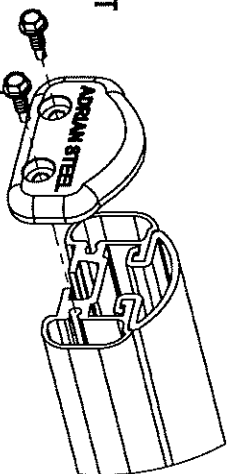

FULLY TIGHTEN
(2) FAS0473, 63851
(2 PLACES PER END CAP)
5/16" SOCKET

USED FOR Prolift RACKS
LOCATED IN Prolift Kit

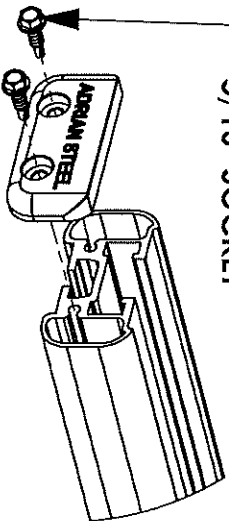

7T. INSTALL ROOF RAIL KIT ON VEHICLE ROOF OR BOTTOM MOUNTING BRACKETS

(ROOF RAIL KIT REQUIRED FOR Grip-Lock & Prolift OPTIONAL FOR HD UTILITY, NOT NEEDED FOR GM LADDER RACKS)

8T. MOUNT CROSSBOW SUB-ASSEMBLIES FROM STEP 1 TO VEHICLE/MOUNTING BRACKET, OR ROOF RAIL (LOOSE INSTALL)

ALTERNATE ASSEMBLY METHOD!
(ASSEMBLE ON VEHICLE ROOF):

- 2R. INSTALL ROOF RAIL KIT ON VEHICLE ROOF OR BOTTOM MOUNTING BRACKETS
(ROOF RAIL KIT REQUIRED FOR Grip-Lock & ProLift, OPTIONAL FOR HD UTILITY, NOT NEEDED FOR GM LADDER RACKS)
- 3R. MOUNT CROSSBOW SUB-ASSEMBLIES FROM STEP 1 TO VEHICLE/MOUNTING BRACKET, OR ROOF RAIL (LOOSE INSTALL)
- 4R. ADD DRIVELINES (IF INSTALLING ProLift)
- 5R. ADD HANDLES (IF INSTALLING Grip-Lock OR ProLift) AND DAMPERS (IF INSTALLING ProLift)
- 6R. ADD OUTER SUPPORT BARS (IF INSTALLING Grip-Lock OR ProLift)
- 7R. ADD STEP LADDER KIT (Grip-Lock OR ProLift ONLY!)

8R. ASSEMBLE END CAPS TO CROSSBOW

USED FOR HD UTILITY & Grip-Lock RACKS

LOCATED IN CROSSBOW KIT

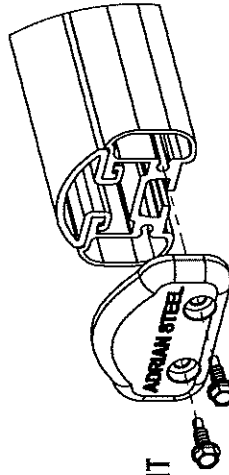

FULLY TIGHTEN
(2) FAS0473, 63851
(2 PLACES PER END CAP)
5/16" SOCKET

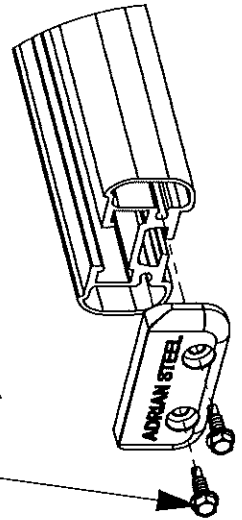

USED FOR ProLift RACKS
LOCATED IN ProLift Kit