

INSTR. NUMBER : 64474	PG: 1	REV: C	ITEM NO.	PART NUMBER	DESCRIPTION	
PART NUMBER • MMMBK4W • 2BARCW			1	63913-W	UTILITY,METRIS MNT BKT, W	4
			2	47106	GASKET,FOOT,MR TRANS L/R	2
			3	63933	UTILITY, COM MOUNT PLATE	4
PART • MM MOUNTING BRKT KIT 4,W DESC. • 2BAR UTILITY RACK, CV, W			4*	63915-W	UTILITY, CROSSBOW, 58", W	2
			5*	63914	UTILITY, WEAR STRIP, 58"	2
			6*	63851	UTILITY RCK,END CAP,BLACK	4
			8	FAS0552	Washer, Flat, 5/16, SST	1

NOTE: THIS ASSEMBLY INSTRUCTION IS VALID FOR ANY NUMBER OF MMMBK.

ITEMS NOTED (#*) ARE PART OF 2BARCW.

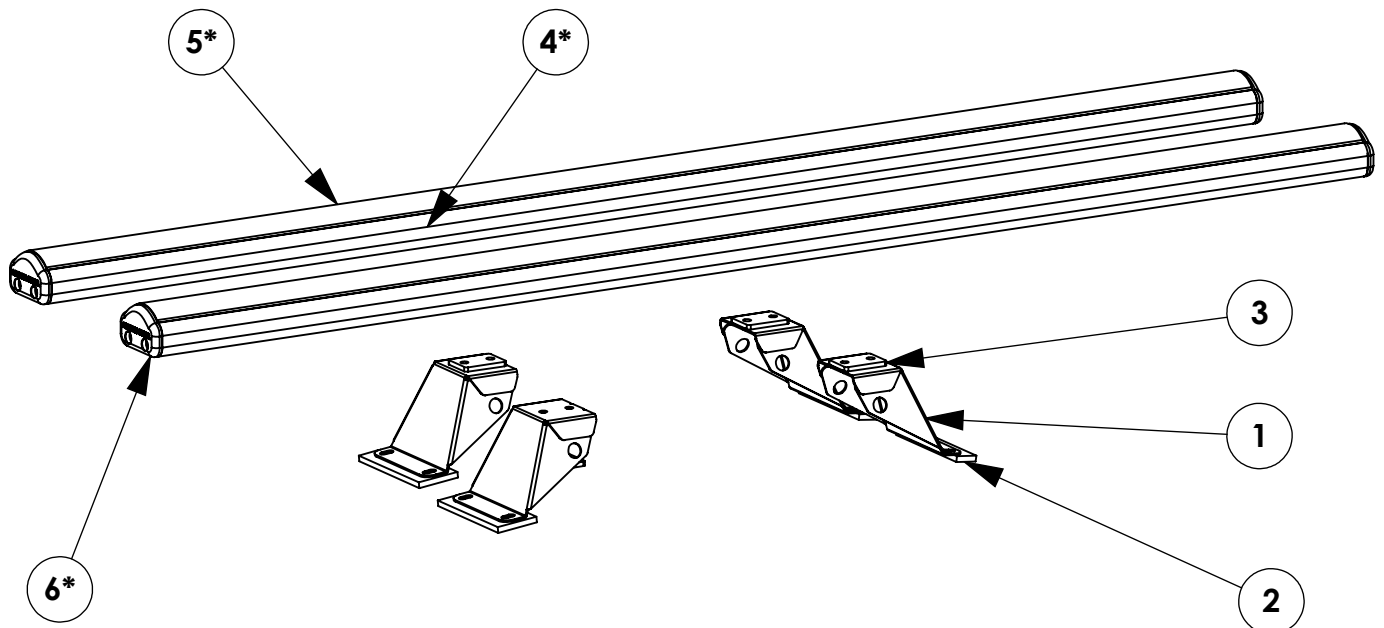

GET TO KNOW THE VEHICLE - AT THE BEGINNING OF ANY INSTALLATION, CHECK THE LOCATION OF THE FUEL TANK, FUEL LINES, BRAKE LINES, HIGH VOLTAGE BATTERIES AND WIRING HARNESSSES TO AVOID INJURY OR PROPERTY DAMAGE FROM TOOL CONTACT.

SEAL ALL EXTERIOR HOLES - ALL INSTALLATION HOLES SHOULD BE SEALED WITH BUTYL TAPE OR SILICON TO PREVENT WATER AND EXHAUST GASES FROM ENTERING THE VEHICLE.

CONTROL DRILL DEPTH - TO AVOID DAMAGE TO THE VEHICLE, USE A DRILL STOP OR CLEARED STEP BIT WHEN DRILLING INSTALLATION HOLES.

ALWAYS ADD PRIMER - WHEN ADDING INSTALLATION HOLES BE SURE TO USE A SELF-ETCHING PRIMER TO PREVENT CORROSION, FASTENER FAILURE AND INJURY.

MOUNTING POINTS MUST HAVE METAL-TO-METAL CONTACT - USE PROVIDED MOUNTING SPACERS TO ACCOMMODATE FOR VEHICLE FEATURES, CARPET OR SUBFLOORS.

PROVIDE CLEARANCE FOR SPACERS - IF THE INSTALLATION VEHICLE CONTAINS A CARPET OR SUBFLOOR, USE A 1-3/16" DIAMETER CARPET CUTTER (P/N: 31183-0) AT ALL MOUNTING LOCATIONS TO OPEN UP ROOM FOR SPACERS.

CHECK SPACER ORIENTATION - BE SURE THAT THE INDENT IN THE SPACER COVERS THE PLUSNUT HEAD; THIS ENSURES THE MOST METAL-TO-METAL CONTACT AND REDUCES VIBRATION.

PLUSNUT INSTALLATION - A PLUSNUT GUN IS RECOMMENDED FOR PLUSNUT INSTALLATION FOR ITS PRODUCTION SPEED. HOWEVER, A PLUSNUT SETTING TOOL CAN ALSO BE USED (P/N: 22200-0).

THRU-BOLT CLEARANCE - WHEN USING A THRU-BOLT AT ANY MOUNTING LOCATION, BE SURE THAT YOUR HOLE HAS 1/16" CLEARANCE.

FASTENERS USED

QUANTITIES ARE LISTED FOR MMMBK4W,
WILL VARY FOR DIFFERENT QUANTITY
OF CROSSBOWS

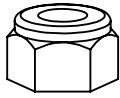

FAS0248
5/16-18 SS
NLK HH NUT
QTY: 8

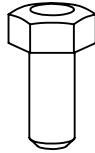

FAS0268
M6-1.0X14 SS
HLFNG SCREW
QTY: 8

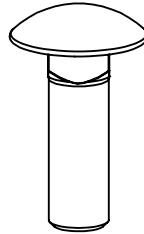

FAS0398
5/16-18X1 SS
CRG BOLT
QTY: 8



FAS0473
12X.75 ZN/NI PLTD
HH TEK SCREW
QTY: 8



FAS0234
1/4 SS
FLAT WASHER
QTY: 8



FAS0672
1/4 SS
SPLIT WASHER
QTY: 8



FAS0552
5/16 SS
FLAT WASHER
QTY: 8

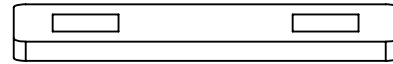

63934
UTILITY,
BOLT PLATE
QTY: 4

BEGIN ASSEMBLY

STEP 1 - ASSEMBLE FEET TO CROSSBOW

IF A CONDUIT KIT OR LADDER RACK ACCESSORY IS PRESENT, CHECK FOR ALTERATION INSTRUCTIONS NOW!

SLIDE WEAR STRIP INTO RAIL AND CENTER (1 PER CROSSBOW)

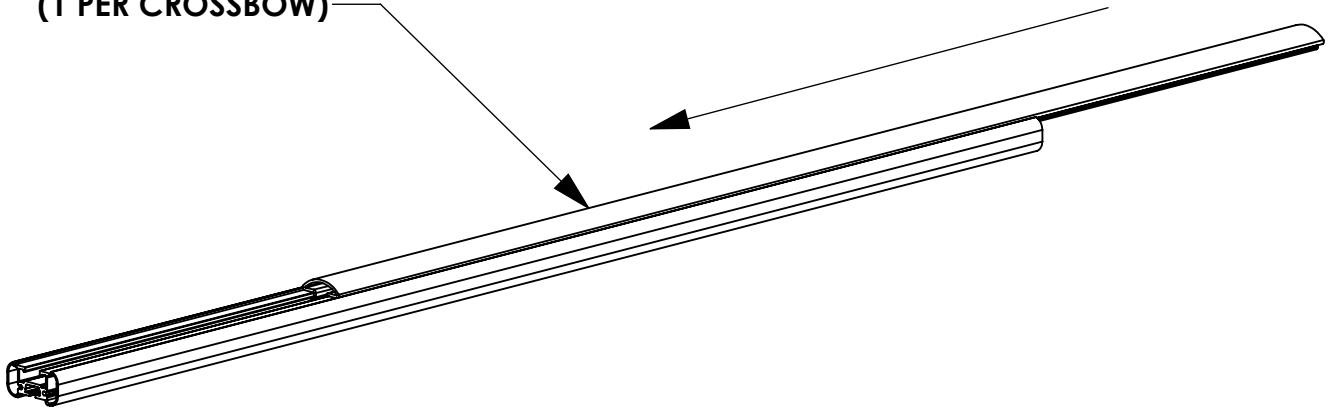

STEP 2 - INSTALL ACCESSORY SLIDES

CHECK FOR A MOUNTING BRACKET OR LADDER RACK ACCESSORY KIT FOR SLIDES.

**63934, (2)FAS0398
(2 PLACES FOR MOUNTING BRACKETS)**

ADDITIONAL SLIDE GUIDE

**(+2 FOR REAR ROLLER)
(+1 PER UPRIGHT)
(+1 PER LADDER STOP)**

REFERENCE ACCESSORY KIT INSTRUCTIONS FOR SPECIFIC CARRIAGE BOLT AND PLATE PART NUMBERS

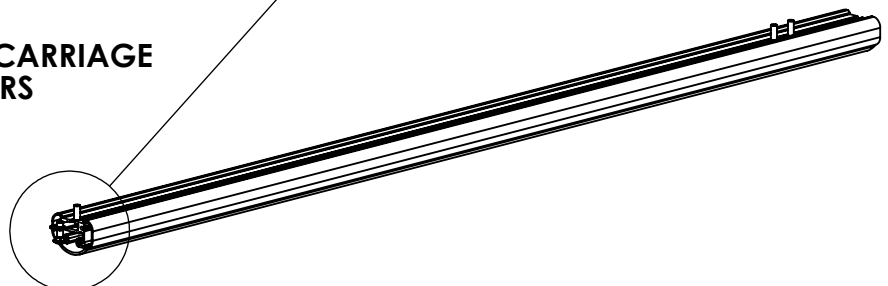
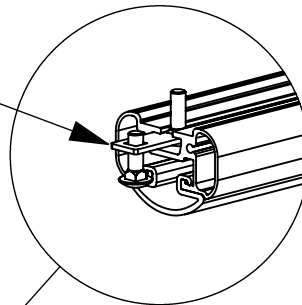

STEP 3 - ASSEMBLE MOUNTING BRACKETS TO CROSSBOW

(2)FAS0398, 63934,
(2)FAS0552, (2)FAS0248
(2 PLACES PER CROSSBOW)
LOOSE INSTALL

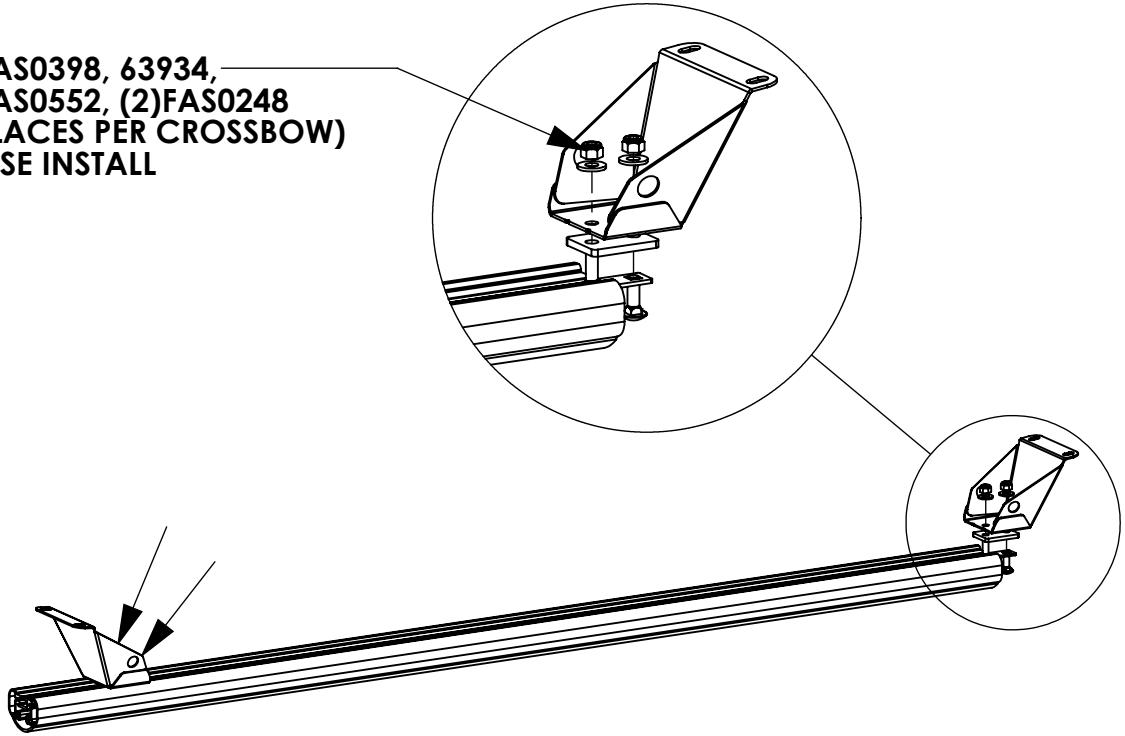

STEP 4 - ASSEMBLE END CAPS TO CROSSBOW

FAS0473
(4 PLACES PER CROSSBOW)
5/16 SOCKET

THESE END CAPS COME IN THE CROSSBOW KIT. BE SURE THAT ALL WEAR STRIPS, SLIDES AND RACK ACCESSORIES ARE INSTALLED PRIOR TO ADDING END CAPS!

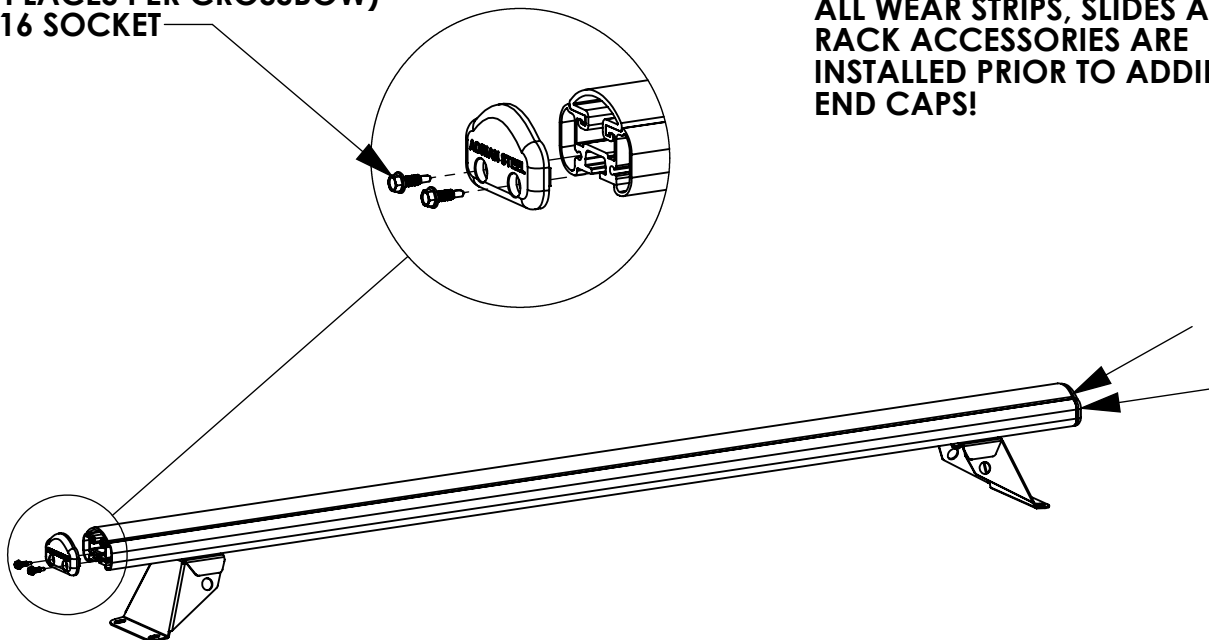

STEP 5 - CUT FOAM STRIPS IN HALF

CUT BOTH FOAM STRIPS IN HALF DOWN THE LENGTH

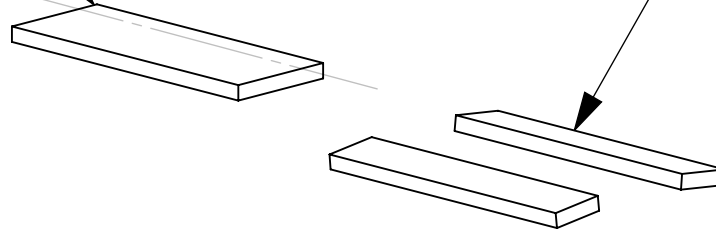

USE (1) OF THESE HALVES FOR EACH MOUNTING BRACKET

BEGIN INSTALLATION

STEP 6 - INSTALL CROSSBOW ASSEMBLY TO VAN ROOF

MOUNT ONE CROSSBOW ON THE REARMOST LOCATION. MOUNT THE SECOND CROSSBOW BASED ON INVENTORY LENGTH.

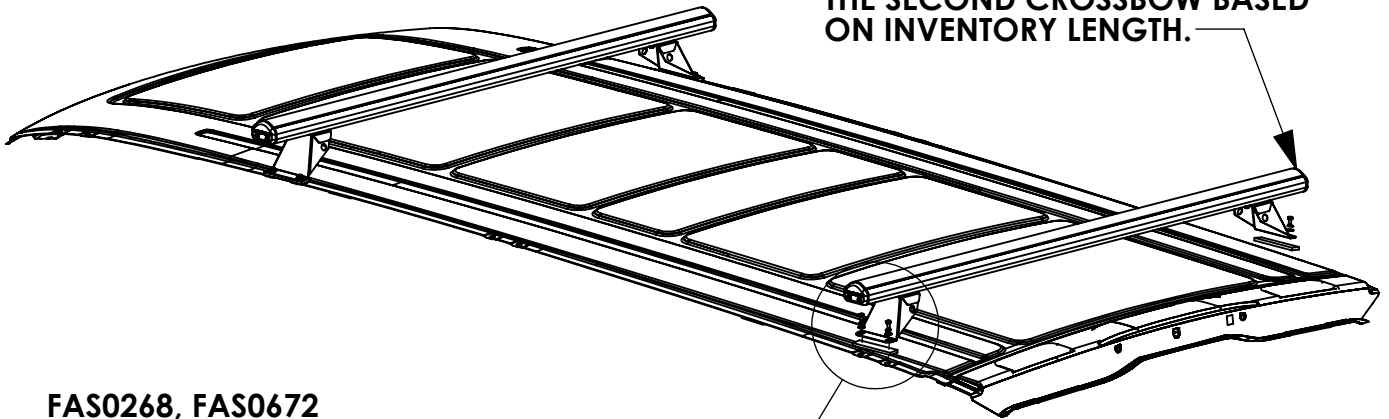

FAS0268, FAS0672
FAS0234
(4 PLACES PER CROSSBOW)
10mm SOCKET

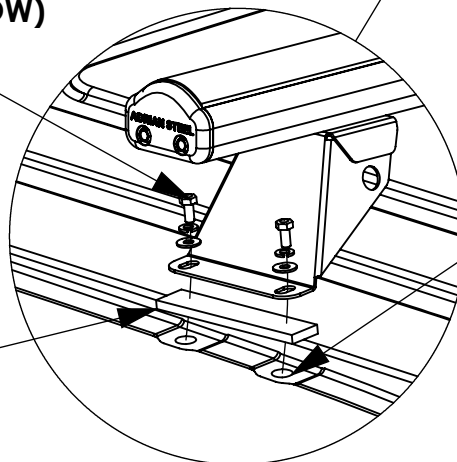

POKE FASTENERS THROUGH FOAM PAD

MOUNT TO OEM LOCATIONS

STEP 7 - SECURE CROSSBOW

**MEASURE TO OUTSIDE
EDGE OF MOUNTING
BRACKET**

