

INSTR. NUMBER	PG.	REV.	ITEM NO.	PART NUMBER	DESCRIPTION	GL-TOPPS	GL-TOPDS
: 69372	1	A	1	66359	GRIP LOCK FRONT BRACE ASSM CS	1	-
			2	66360	GRIP LOCK REAR BRACE ASSM CS	1	-
			3	69244	GRIP-LOCK, TOP OUT TUB, ASM	1	1
PART NUMBER : GL-TOPPS & GL-TOPDS	4	25340-0	HANDLE LATCH-STD	1	1		
	5	66291-W	GRIP LOCK HANDLE, WHITE	1	1		
PART • GRIP-LOCK, TOPPER, PS DESC. • GRIP-LOCK, TOPPER, DS	6	50981-B	FRONT STOP POST	1	1		
	7	66289-W	GRIP LOCK HANDLE POST, WHITE	1	1		
<b>NOTE: THIS INSTRUCTION IS VALID FOR THE FOLLOWING KITS:</b>	8	66292-B	CLAMP PAD, BLACK	2	2		
	9	27254-B	SLEEVE-HORN, L.R. BLACK	1	1		
	10	66361	GRIP LOCK FRONT BRACE SS ASSM	-	1		
	11	66362	GRIP LOCK REAR BRACE ASSM SS	-	1		

- GL-TOPPS
  - GL-TOPDS
  - GL-TOPPSB
  - GL-TOPDSB
- PART NUMBERS WITH "-W" SUFFIX ARE PAINTED WHITE
  - FOR BLACK GRIP-LOCK™, REPLACE "-W" PARTS WITH "-B" PARTS
  - INSTRUCTION SHOWS INSTALL FOR GL-TOPPS.
  - MIRROR STEPS FOR GL-TOPDS

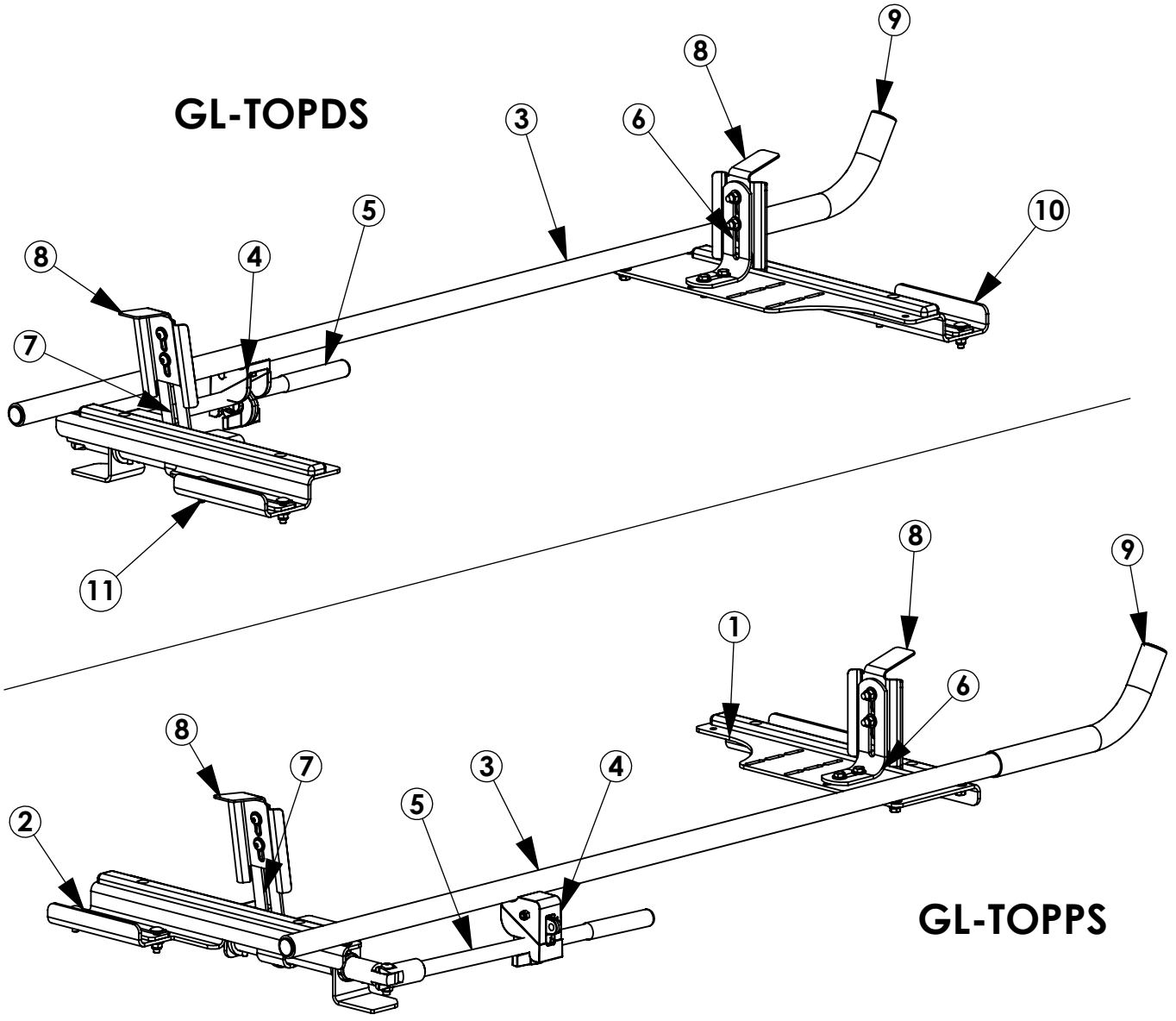

**GET TO KNOW THE VEHICLE** - AT THE BEGINNING OF ANY INSTALLATION, CHECK THE LOCATION OF THE FUEL TANK, FUEL LINES, BRAKE LINES, HIGH VOLTAGE BATTERIES AND WIRING HARNESSSES TO AVOID INJURY OR PROPERTY DAMAGE FROM TOOL CONTACT.

**SEAL ALL EXTERIOR HOLES** - ALL INSTALLATION HOLES SHOULD BE SEALED WITH BUTYL TAPE OR SILICON TO PREVENT WATER AND EXHAUST GASES FROM ENTERING THE VEHICLE.

**CONTROL DRILL DEPTH** - TO AVOID DAMAGE TO THE VEHICLE, USE A DRILL STOP OR CLEARED STEP BIT WHEN DRILLING INSTALLATION HOLES.

**ALWAYS ADD PRIMER** - WHEN ADDING INSTALLATION HOLES BE SURE TO USE A SELF-ETCHING PRIMER TO PREVENT CORROSION, FASTENER FAILURE AND INJURY.

**MOUNTING POINTS MUST HAVE METAL-TO-METAL CONTACT** - USE PROVIDED MOUNTING SPACERS TO ACCOMMODATE FOR VEHICLE FEATURES, CARPET OR SUBFLOORS.

**PROVIDE CLEARANCE FOR SPACERS** - IF THE INSTALLATION VEHICLE CONTAINS A CARPET OR SUBFLOOR, USE A 1-3/16" DIAMETER CARPET CUTTER (P/N: 31183-0) AT ALL MOUNTING LOCATIONS TO OPEN UP ROOM FOR SPACERS.

**CHECK SPACER ORIENTATION** - BE SURE THAT THE INDENT IN THE SPACER COVERS THE PLUSNUT HEAD; THIS ENSURES THE MOST METAL-TO-METAL CONTACT AND REDUCES VIBRATION.

**PLUSNUT INSTALLATION** - A PLUSNUT GUN IS RECOMMENDED FOR PLUSNUT INSTALLATION FOR ITS PRODUCTION SPEED. HOWEVER, A PLUSNUT SETTING TOOL CAN ALSO BE USED (P/N: 22200-0).

**THRU-BOLT CLEARANCE** - WHEN USING A THRU-BOLT AT ANY MOUNTING LOCATION, BE SURE THAT YOUR HOLE HAS 1/16" CLEARANCE.

**FASTENERS USED**

**QUANTITIES PROVIDED ARE FOR A SINGLE SIDE INSTALL**

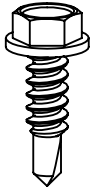

**FAS0473**  
**#12x.75**  
**HH TEK SCREW**  
**QTY: 4**

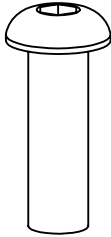

**FAS0813**  
**5/16-18 X 1.0 SS**  
**BHC SCREW**  
**QTY: 4**

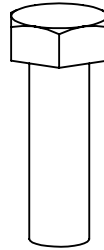

**FAS0597**  
**5/16-18 X 1.0 SS**  
**HH SCREW**  
**QTY: 2**

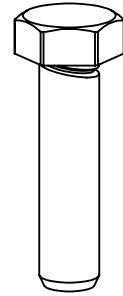

**FAS0830**  
**5/16-18 X 1.25 SS**  
**HH SCREW**  
**QTY: 4**

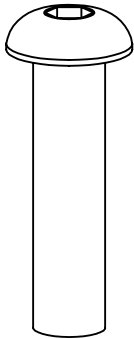

**FAS0819**  
**5/16-18 X 1.5 SS**  
**BHC SCREW**  
**QTY: 1**

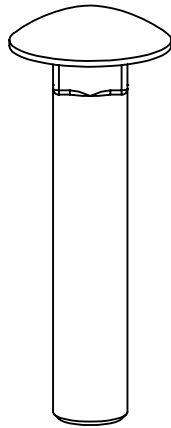

**FAS0721**  
**3/8-16 X 2.0 SS**  
**CRG BOLT**  
**QTY: 1**



**FAS0588**  
**5/16-18 SS**  
**SPLIT WASHER**  
**QTY: 4**



**FAS0552**  
**5/16-18 SS**  
**FLAT WASHER**  
**QTY: 16**

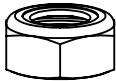

**FAS0399**  
**3/8-16 SS**  
**NYL NUT**  
**QTY: 1**

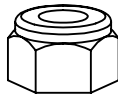

**FAS0248**  
**5/16-18 SS**  
**NYL NUT**  
**QTY: 6**

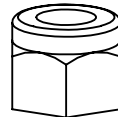

**FAS0110**  
**3/8-16 SS**  
**NYL NUT**  
**QTY: 1**

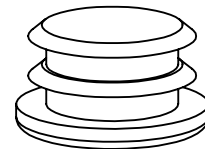

**51363**  
**1" RND BLK**  
**CAP PLUG**  
**QTY: 1**

**63851**  
**CROSSBOW**  
**END CAP**  
**QTY: 2**



**BEGIN ASSEMBLY**

**STEP 1 - ASSEMBLE REAR CLAMP AND HANDLE**

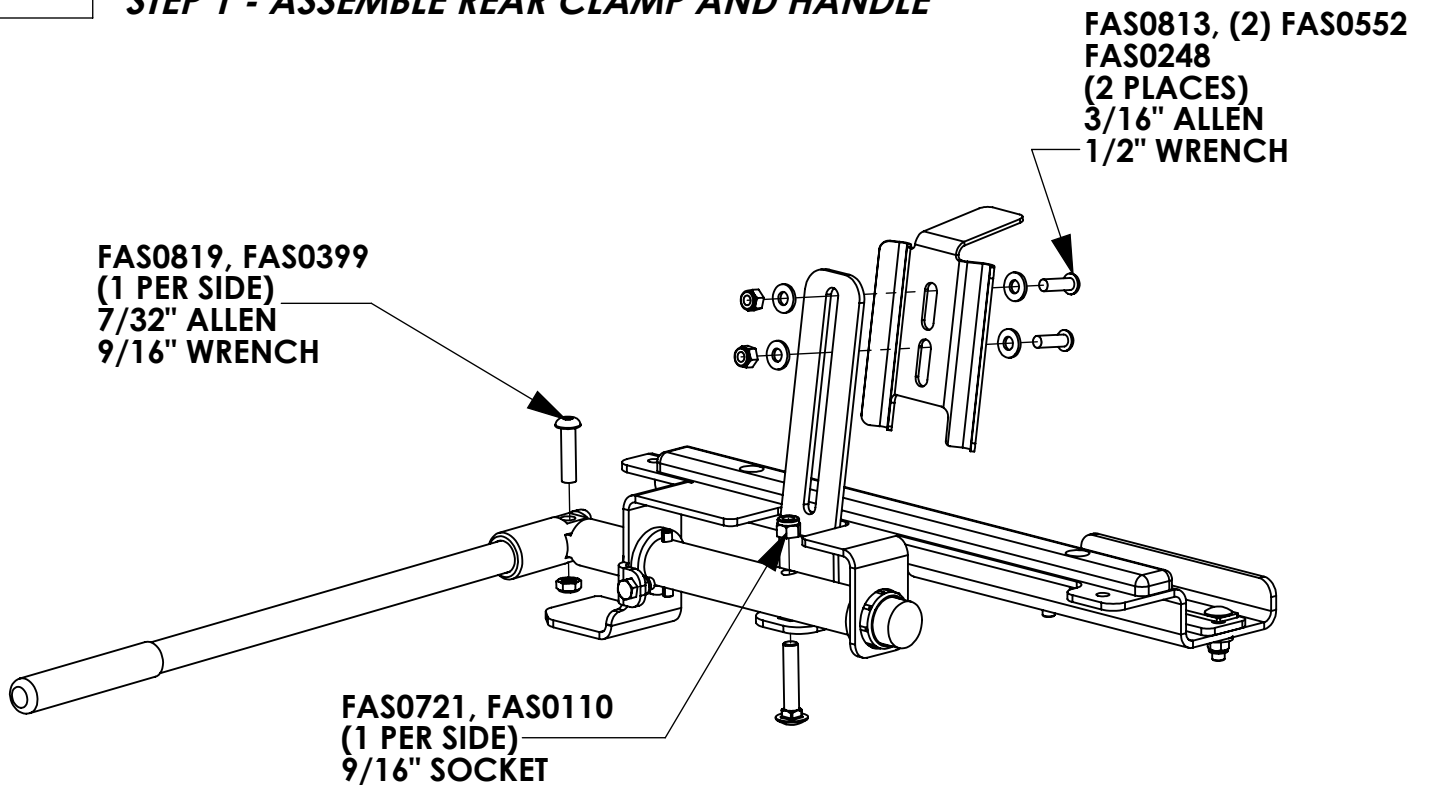

**STEP 2 - ASSEMBLE FRONT CLAMP**

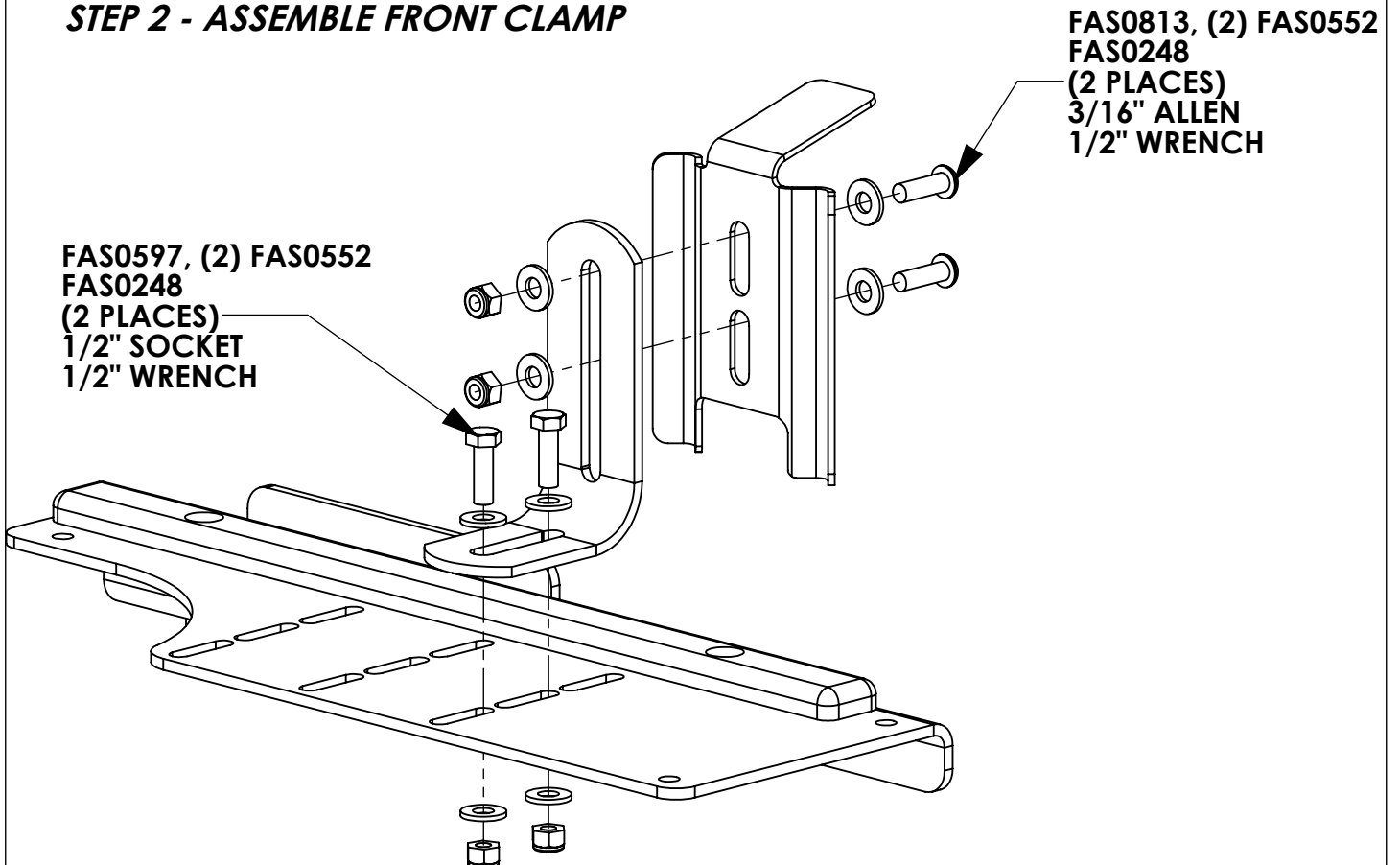

**STEP 3 - ASSEMBLE OUTER TUBE**

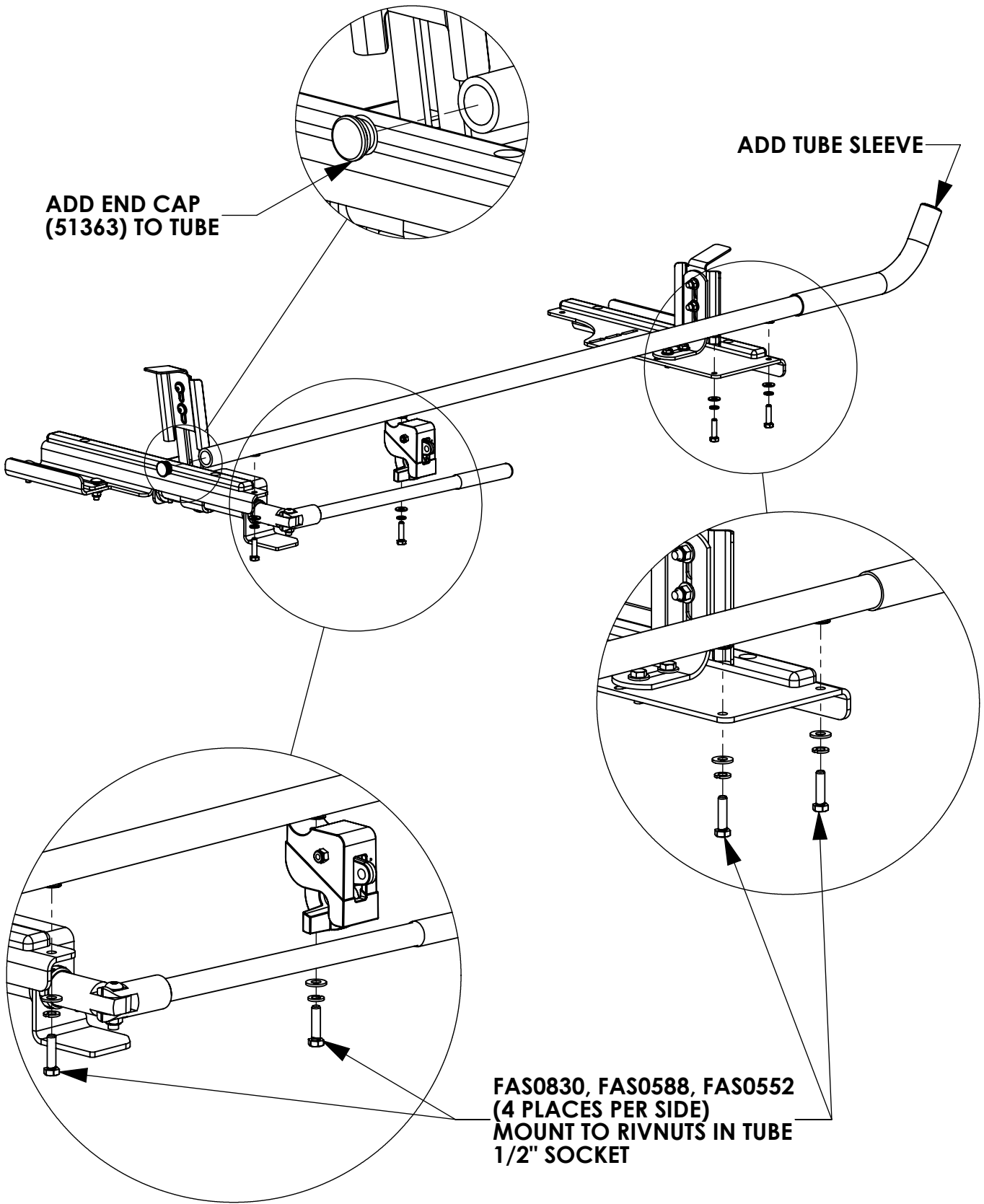

**ADD END CAP  
(51363) TO TUBE**

**ADD TUBE SLEEVE**

**FAS0830, FAS0588, FAS0552  
(4 PLACES PER SIDE)  
MOUNT TO RIVNUTS IN TUBE  
1/2\" SOCKET**

**STEP 4 - SUB-ASSEMBLY ON CROSSBOWS**

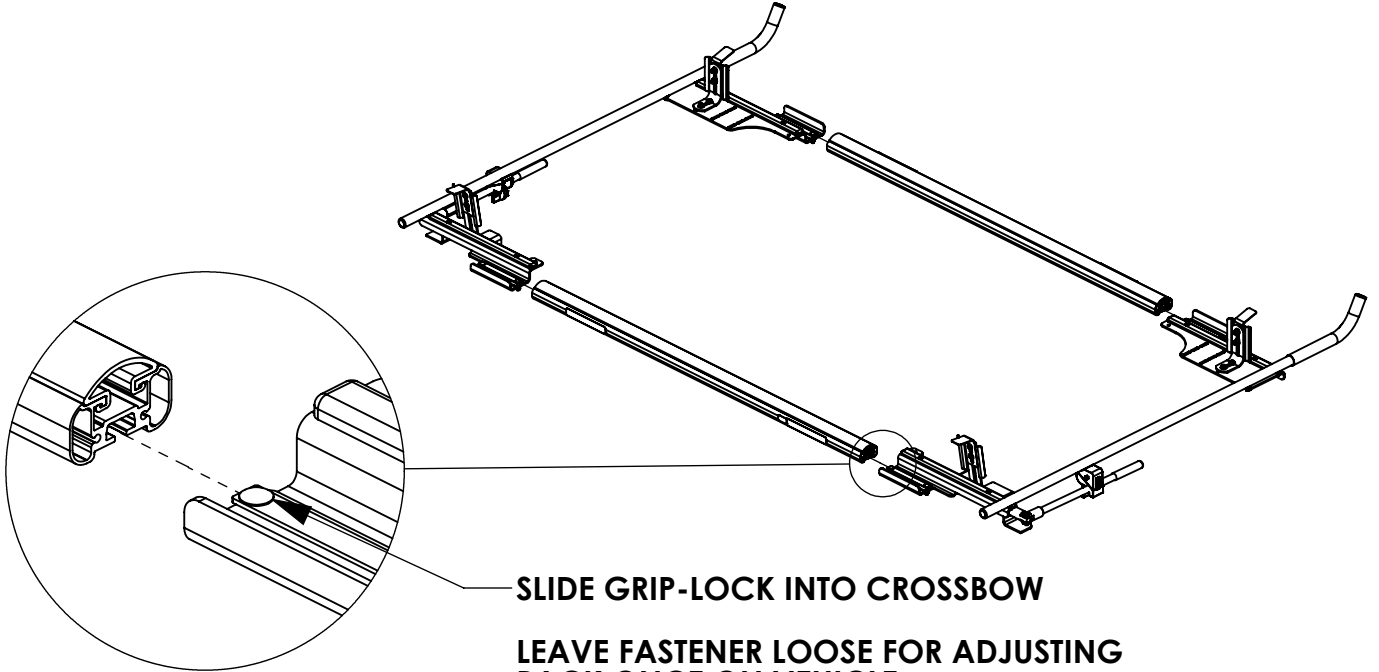

**SLIDE GRIP-LOCK INTO CROSSBOW**

**LEAVE FASTENER LOOSE FOR ADJUSTING  
RACK ONCE ON VEHICLE**

**ONCE IN POSITION, TIGHTEN ALL LOCATIONS  
(4 PLACES PER SIDE)  
1/2" SOCKET**

**STEP 5 - ASSEMBLE END CAPS TO CROSSBOWS**

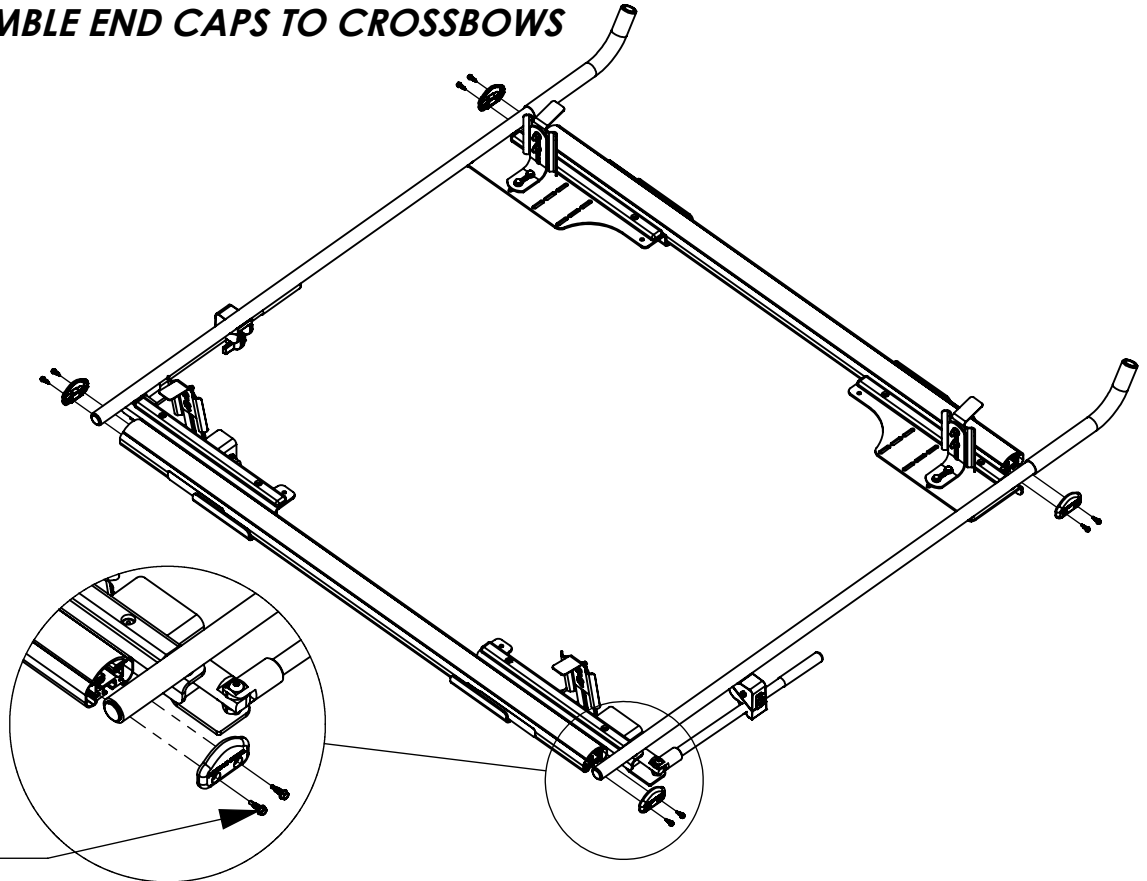

**FAS0473  
(2 PER END CAP)  
3/8" SOCKET**

INSTR. NUMBER : <b>69907</b> PART NUMBER : <b>MAVRMBK4</b> PART DESC. : MAV RAIL MNT BKT KT,4	PG: <b>1</b>	REV: <b>B</b>	ITEM NO.	PART NUMBER	DESCRIPTION	QTY.
			1	69903-W	MAV RAIL BRKT FDS/RPS,W	2
			2	69904-W	MAV RAIL BRKT FPS/RDS,W	2
			3	68040-W	PROFILE, MOUNTING ARM, SHORT,W	4

- PART NUMBERS WITH "-W" SUFFIX ARE PAINTED WHITE  
 - FOR BLACK MOUNTING KITS, REPLACE "-W" PARTS WITH "-B" PARTS

**NOTE: THIS INSTRUCTION IS VALID FOR THE FOLLOWING KITS:**

- MAVRMBK4W
- MAVRMBK4B

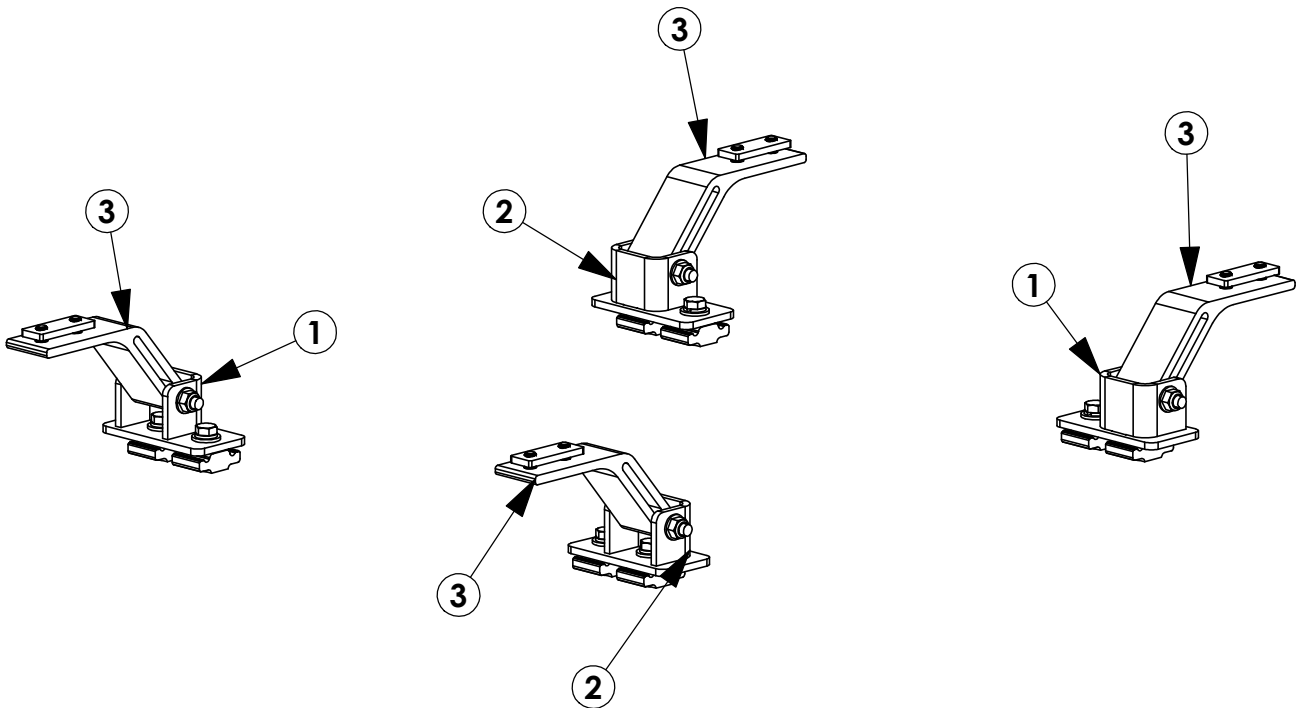

**TOOLS NEEDED:**

- DRIVE RATCHET
- IMPACT DRIVER
- 3/16" SOCKET
- 1/2" SOCKET
- 1/2" WRENCH
- TAPE MEASURE

**GET TO KNOW THE VEHICLE** - AT THE BEGINNING OF ANY INSTALLATION, CHECK THE LOCATION OF THE FUEL TANK, FUEL LINES, BRAKE LINES, HIGH VOLTAGE BATTERIES AND WIRING HARNESSSES TO AVOID INJURY OR PROPERTY DAMAGE FROM TOOL CONTACT.

**SEAL ALL EXTERIOR HOLES** - ALL INSTALLATION HOLES SHOULD BE SEALED WITH BUTYL TAPE OR SILICON TO PREVENT WATER AND EXHAUST GASES FROM ENTERING THE VEHICLE.

**CONTROL DRILL DEPTH** - TO AVOID DAMAGE TO THE VEHICLE, USE A DRILL STOP OR CLEARED STEP BIT WHEN DRILLING INSTALLATION HOLES.

**ALWAYS ADD PRIMER** - WHEN ADDING INSTALLATION HOLES BE SURE TO USE A SELF-ETCHING PRIMER TO PREVENT CORROSION, FASTENER FAILURE AND INJURY.

**MOUNTING POINTS MUST HAVE METAL-TO-METAL CONTACT** - USE PROVIDED MOUNTING SPACERS TO ACCOMMODATE FOR VEHICLE FEATURES, CARPET OR SUBFLOORS.

**PROVIDE CLEARANCE FOR SPACERS** - IF THE INSTALLATION VEHICLE CONTAINS A CARPET OR SUBFLOOR, USE A 1-3/16" DIAMETER CARPET CUTTER (P/N: 31183-0) AT ALL MOUNTING LOCATIONS TO OPEN UP ROOM FOR SPACERS.

**CHECK SPACER ORIENTATION** - BE SURE THAT THE INDENT IN THE SPACER COVERS THE PLUSNUT HEAD; THIS ENSURES THE MOST METAL-TO-METAL CONTACT AND REDUCES VIBRATION.

**PLUSNUT INSTALLATION** - A PLUSNUT GUN IS RECOMMENDED FOR PLUSNUT INSTALLATION FOR ITS PRODUCTION SPEED. HOWEVER, A PLUSNUT SETTING TOOL CAN ALSO BE USED (P/N: 22200-0).

**THRU-BOLT CLEARANCE** - WHEN USING A THRU-BOLT AT ANY MOUNTING LOCATION, BE SURE THAT YOUR HOLE HAS 1/16" CLEARANCE.



**FASTENERS AND HARDWARE USED**  
**BAG REFERENCE: BAG 66848**

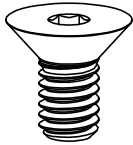

**FAS0858**  
**5/16-18X.63 SS**  
**FHH SCREW**  
**QTY: 8**

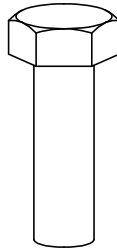

**FAS0597**  
**5/16-18X1.0 SS**  
**HH SCREW**  
**QTY: 8**

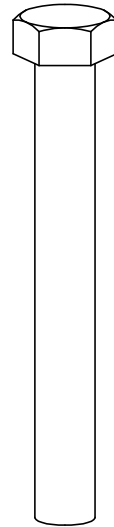

**FAS0243**  
**5/16-18X2.5 SS**  
**HH SCREW**  
**QTY: 4**



**FAS0857**  
**5/16 SS**  
**WASHER, LCK EXT CS**  
**QTY: 8**



**FAS0588**  
**5/16 SS**  
**SPLIT WASHER**  
**QTY: 8**



**FAS0552**  
**5/16 SS**  
**FLAT WASHER**  
**QTY: 12**



**FAS0861**  
**5/16-18 SS**  
**HH FLG NUT**  
**QTY: 4**

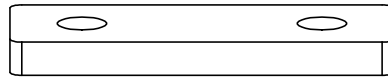

**68042**  
**PROFILE FOOT**  
**MOUNTING PLATE**  
**QTY: 4**

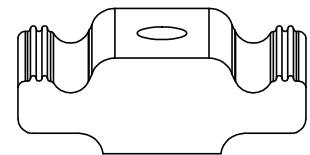

**63490**  
**RAIL SLIDE,**  
**1"**  
**QTY: 8**

**PAGE INTENTIONALLY LEFT BLANK**

# STEP 1 - ASSEMBLE MOUNTING ARMS TO CROSSBOW



CHECK TABLE 1-3 IN INSTRUCTION 68895 FOR ADDITIONAL ACCESSORY SLIDE INSTALLATION BEFORE INSTALLING MOUNTING BRACKETS (ALL A.2 ITEMS SHOULD BE COMPLETELY ASSEMBLED FIRST!)

STEP 1.1  
**LOOSELY ASSEMBLE  
UNTIL AFTER STEP 3**  
(2) FAS0857, (2)  
FAS0858, 68042

(02 PLACES PER  
CROSSBOW)  
3/16" ALLEN

## ATTENTION!

IF INSTALLING A GRIP-LOCK ON A PICKUP TRUCK TOPPER, ASSEMBLE MOUNTING ARMS FACING OUTWARD FOR THAT SIDE OF THE RACK

STEP 1.1

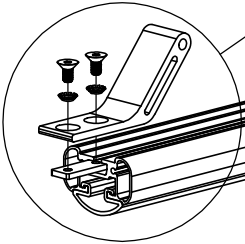
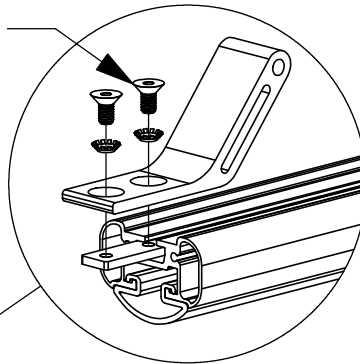

SLIDES AND FASTENERS WILL BE INCLUDED IN THEIR RESPECTIVE KITS. THESE SHOULD BE INSERTED PRIOR TO ASSEMBLING MOUNTING ARMS!

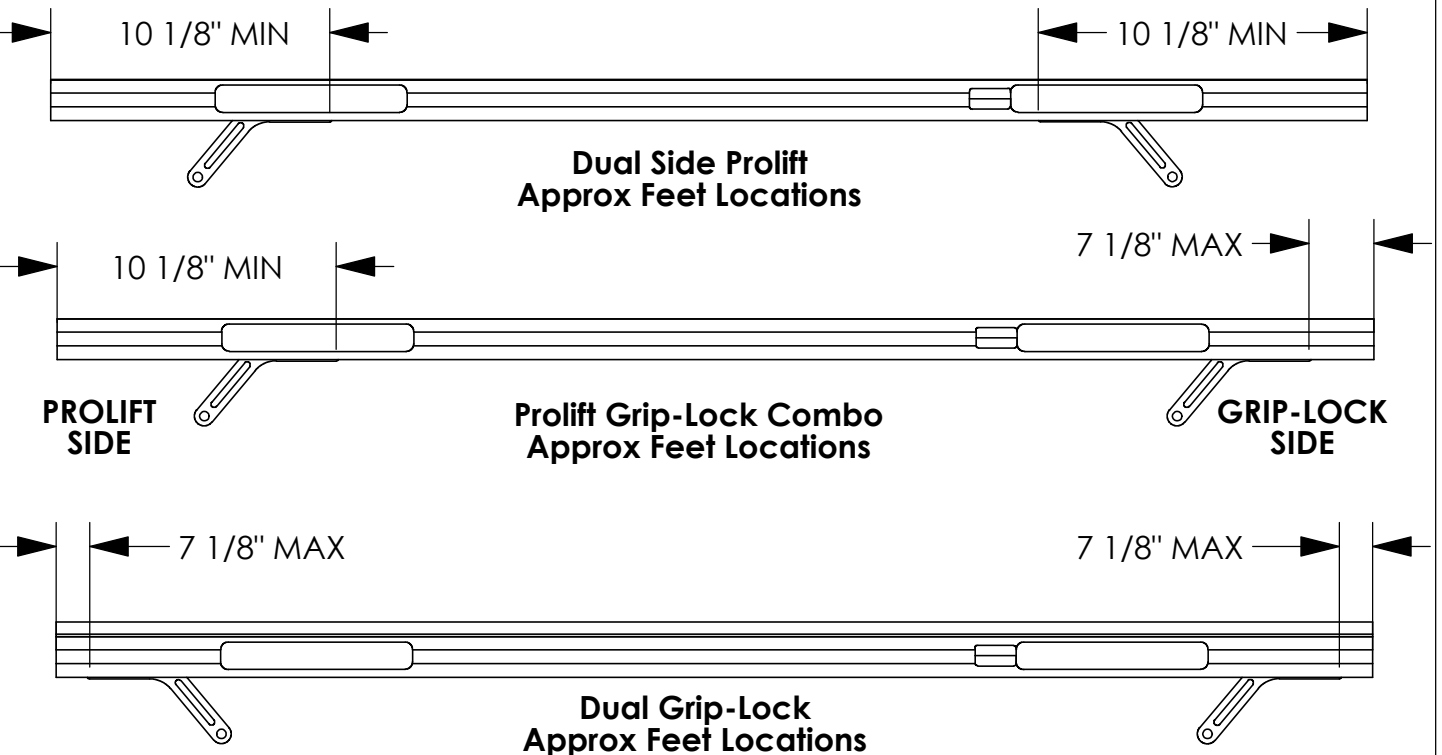

**STEP 2 - ASSEMBLE MOUNTING BRACKETS TO ROOF RAILS**

**STEP 3.1**

**FULLY TIGHTEN**

FAS0597, FAS0552,  
FAS0588, 63490 ON  
REAR MOUNTING FEET

(02 PLACES PER  
MOUNTING FOOT)  
1/2" SOCKET

**STEP 3.2**

**LEAVE LOOSE UNTIL  
AFTER STEP 4**

FAS0597, FAS0552,  
FAS0588, 63490 ON  
FRONT MOUNTING  
FEET

(02 PLACES PER  
MOUNTING FOOT)  
1/2" SOCKET

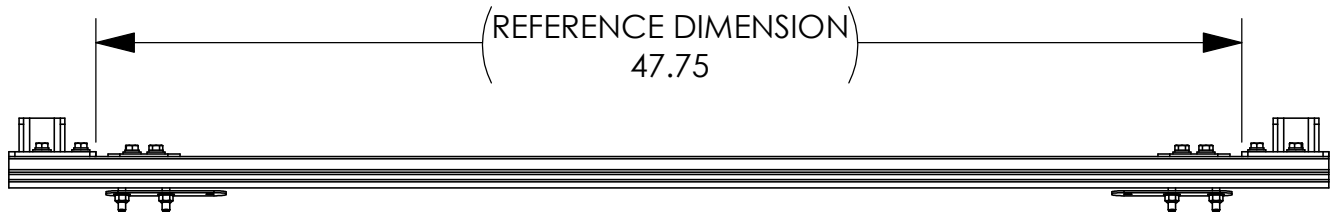
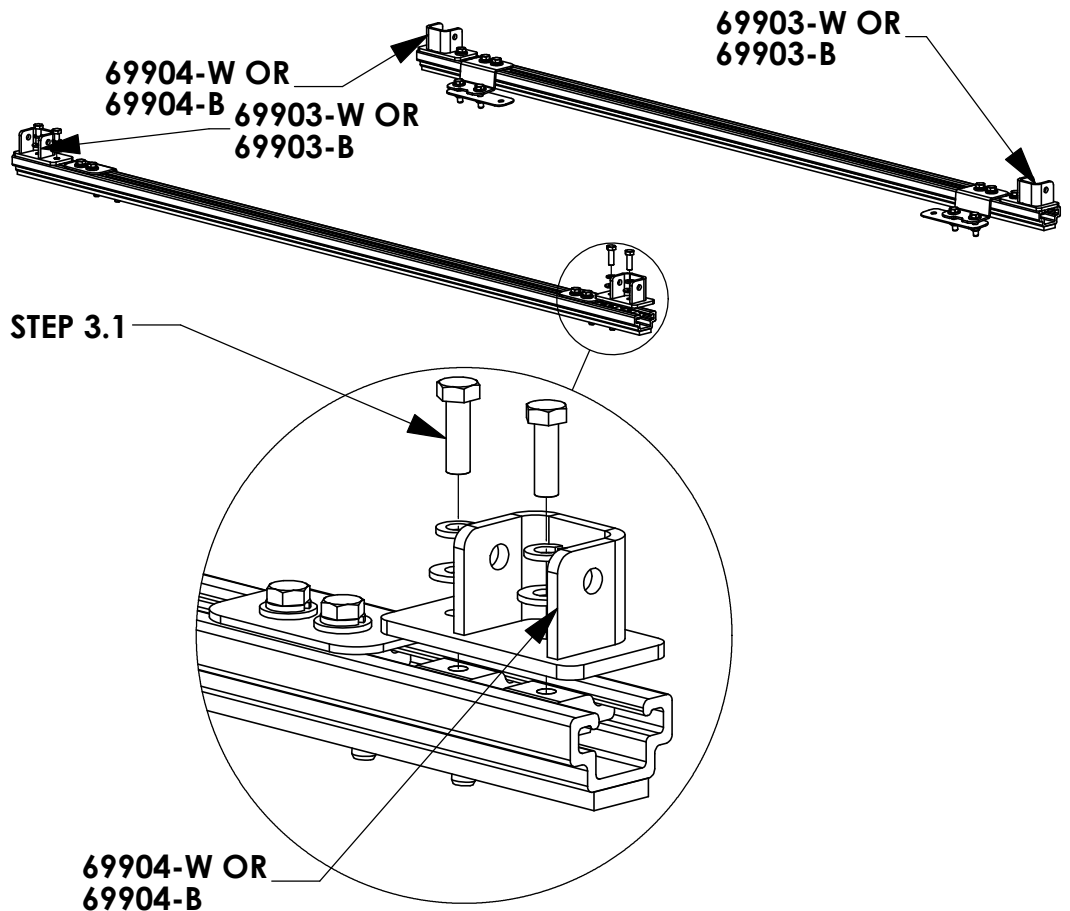

**DO NOT FULLY TIGHTEN! YOU MAY  
NEED TO MOVE BRACKETS SLIGHTLY!**

**CROSSBOW POSITIONING NOTES:**

**HD UTILITY RACK -**

REAR CROSSBOW - REARWARD AS POSSIBLE  
FRONT CROSSBOW - POSITION TO BEST FIT END USER'S PRODUCT

**GRIP-LOCK / PROLIFT LADDER RACKS -**

REFER TO RESPECTIVE INSTRUCTION FOR CROSSBOW PLACEMENT

### STEP 3 - ASSEMBLE MOUNTING BRACKETS TO MOUNTING ARMS



**BEFORE PROCEEDING WITH THIS STEP FINISH ASSEMBLING ACCESSORIES ONTO RACK. (IE GRIP LOCK, PROLIFT, ETC)**

**STEP 4.1**

**FULLY TIGHTEN**

FAS0243, FAS0552,  
FAS0861

(02 PLACES PER  
CROSSBOW)

1/2" SOCKET  
1/2" WRENCH

**STEP 4.2**

**FULLY TIGHTEN**

FAS0597, FAS0552,  
FAS0588, 63490 ON  
FRONT MOUNTING  
FEET

(02 PLACES PER  
MOUNTING FOOT)

1/2" SOCKET

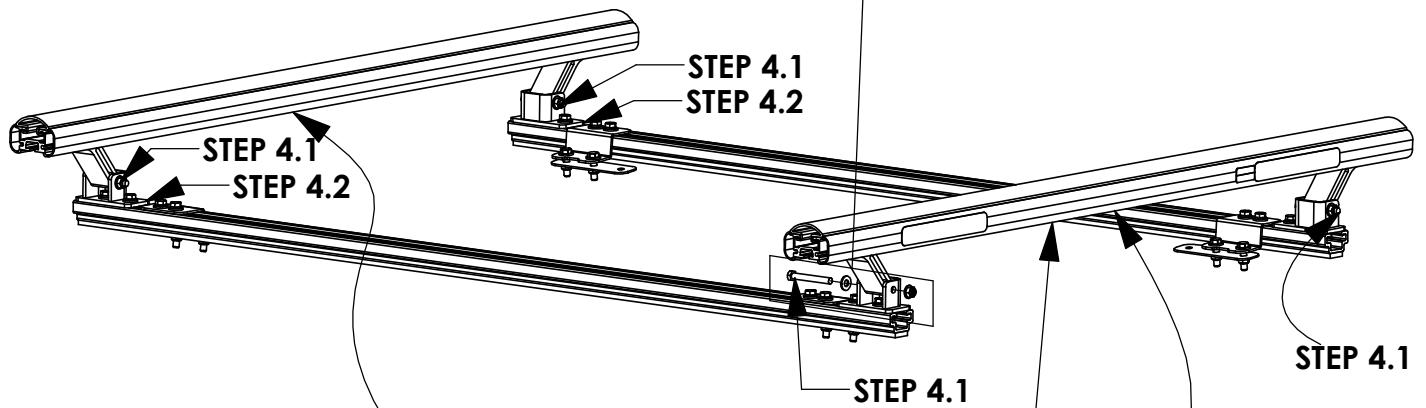
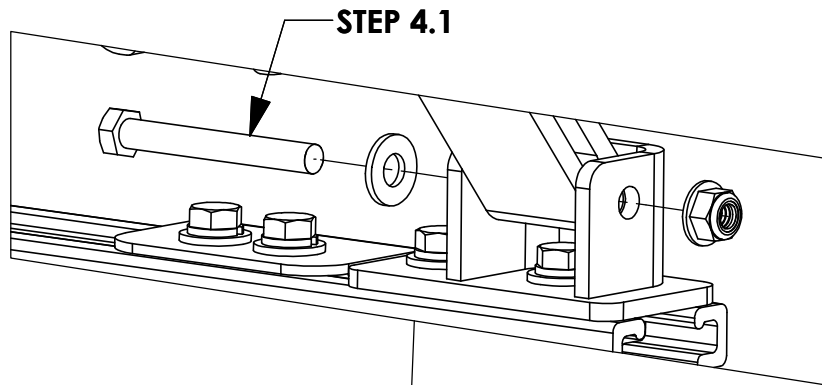

**NOTE ORIENTATION OF LABELS  
ON CROSSBOW**

**REFERENCE - NO ACCESSORIES SHOWN**

**STEP 4 - ADJUST MOUNTING BRACKET LOCATION IF NECESSARY**

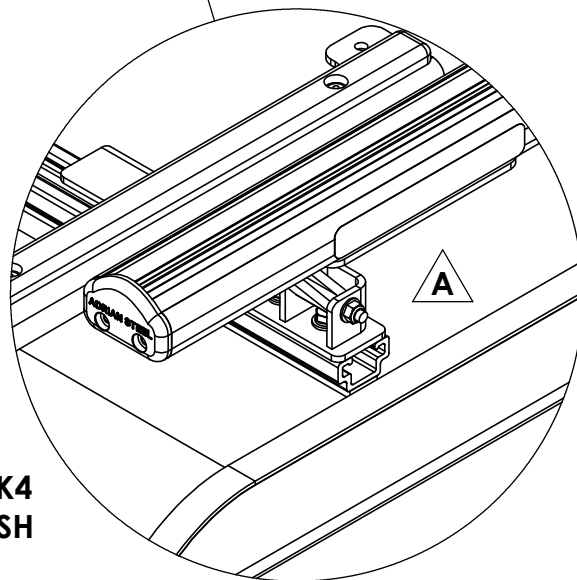
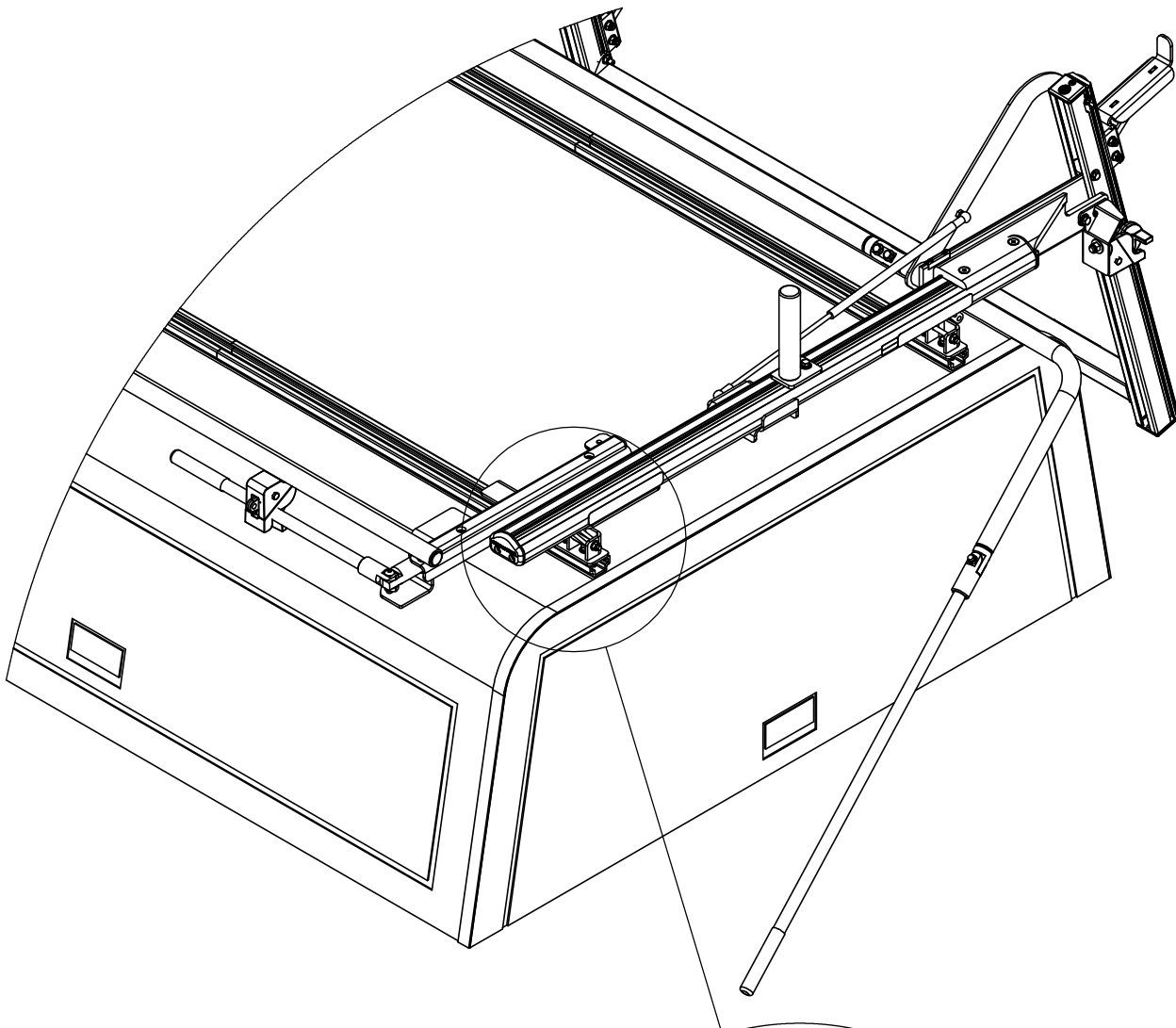

**A** ROOF RAIL KIT AND MAVRMBK4  
KIT MOUNTING BRACKETS ARE FLUSH  
WITH THE REAR TOPPER TRIM

**INSTALLATION IS COMPLETE!! MAKE SURE ALL FASTENERS ARE TIGHTENED**

INSTR. NUMBER : 69251	PG: 1	REV: C	ITEM NO.	PART NUMBER	DESCRIPTION	RRKTOP58	RRKTOP55
PART NUMBER • <b>RRKTOP58</b> PART NUMBER • <b>RRKTOP55</b>			1	BLK63348	RAIL, 58.00	2	-
			2	69241	TOPPER RAIL BRACKET	4	4
PART • ROOF RAIL KIT, TOPPER, 58" DESC. • ROOF RAIL KIT, TOPPER, 55"			3	66056	UTILITY, TOP SUPPORT PLATE	4	4
			4	69902	ROOF RAIL SPRINTER FSV	-	2
			5	63390	FOAM TAPE 1/4X2X120"TB	-	2

**NOTE: THIS INSTRUCTION IS VALID FOR THE FOLLOWING KITS:**

- RRKTOP58 (SHOWN)
- RRKTOP55 / 66982

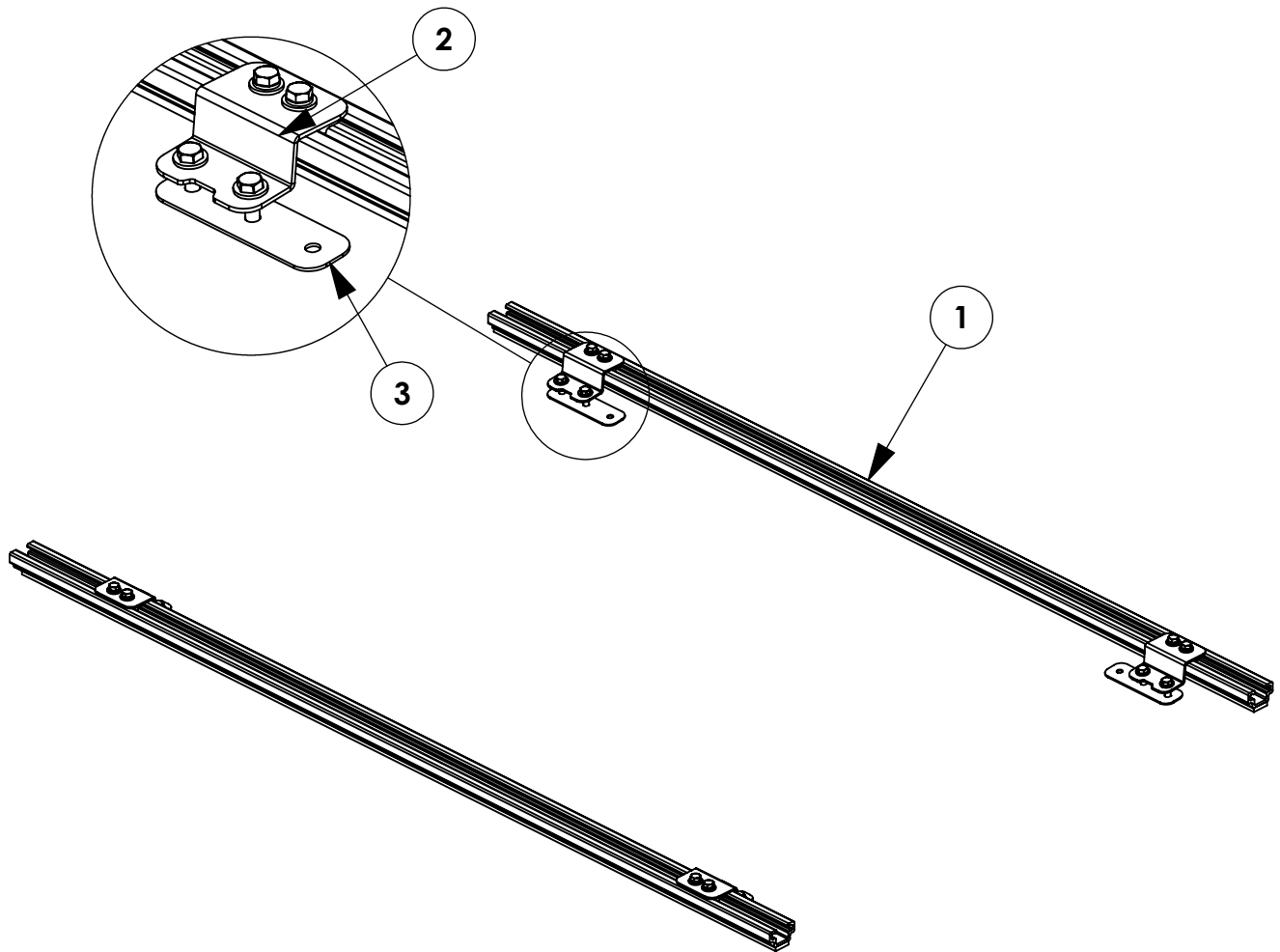

**GET TO KNOW THE VEHICLE** - AT THE BEGINNING OF ANY INSTALLATION, CHECK THE LOCATION OF THE FUEL TANK, FUEL LINES, BRAKE LINES, HIGH VOLTAGE BATTERIES AND WIRING HARNESES TO AVOID INJURY OR PROPERTY DAMAGE FROM TOOL CONTACT.

**SEAL ALL EXTERIOR HOLES** - ALL INSTALLATION HOLES SHOULD BE SEALED WITH BUTYL TAPE OR SILICON TO PREVENT WATER AND EXHAUST GASES FROM ENTERING THE VEHICLE.

**CONTROL DRILL DEPTH** - TO AVOID DAMAGE TO THE VEHICLE, USE A DRILL STOP OR CLEARED STEP BIT WHEN DRILLING INSTALLATION HOLES.

**ALWAYS ADD PRIMER** - WHEN ADDING INSTALLATION HOLES BE SURE TO USE A SELF-ETCHING PRIMER TO PREVENT CORROSION, FASTENER FAILURE AND INJURY.

**MOUNTING POINTS MUST HAVE METAL-TO-METAL CONTACT** - USE PROVIDED MOUNTING SPACERS TO ACCOMMODATE FOR VEHICLE FEATURES, CARPET OR SUBFLOORS.

**PROVIDE CLEARANCE FOR SPACERS** - IF THE INSTALLATION VEHICLE CONTAINS A CARPET OR SUBFLOOR, USE A 1-3/16" DIAMETER CARPET CUTTER (P/N: 31183-0) AT ALL MOUNTING LOCATIONS TO OPEN UP ROOM FOR SPACERS.

**CHECK SPACER ORIENTATION** - BE SURE THAT THE INDENT IN THE SPACER COVERS THE PLUSNUT HEAD; THIS ENSURES THE MOST METAL-TO-METAL CONTACT AND REDUCES VIBRATION.

**PLUSNUT INSTALLATION** - A PLUSNUT GUN IS RECOMMENDED FOR PLUSNUT INSTALLATION FOR ITS PRODUCTION SPEED. HOWEVER, A PLUSNUT SETTING TOOL CAN ALSO BE USED (P/N: 22200-0).

**THRU-BOLT CLEARANCE** - WHEN USING A THRU-BOLT AT ANY MOUNTING LOCATION, BE SURE THAT YOUR HOLE HAS 1/16" CLEARANCE.



***FASTENERS USED***

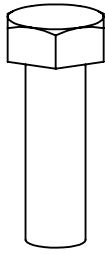

**FAS0597  
5/16-18X1.0 SS  
HH SCREW  
QTY: 8**



**FAS0830  
5/16-18X1.25 SS  
SCREW, HH  
QTY: 8**



**FAS0588  
5/16 SS  
SPLIT WASHER  
QTY: 8**



**FAS0552  
5/16 SS  
FLAT WASHER  
QTY: 16**

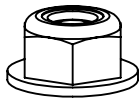

**FAS0861  
5/16-18 SS  
HH FLG NUT  
QTY: 8**

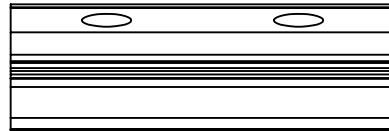

**63491  
RAIL SLIDE  
2"  
QTY: 4**

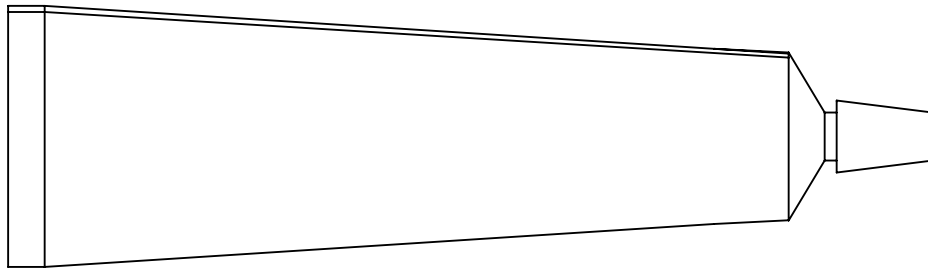

**26618-0  
SILICONE  
1 OZ TUBE  
QTY: 1**

**STEP 1 - ASSEMBLE BRACKETS TO ROOF RAILS**

**ADD SLIDES FOR MOUNTING BRACKETS BEFORE ADDING SLIDES FOR RAIL BRACKETS!!**

**BRACKET LOCATIONS WILL BE DETERMINED BY THE SIZE AND SPACING OF THE WELDED REINFORCEMENT PLATES PROVIDED WITH THE TOPPER.**

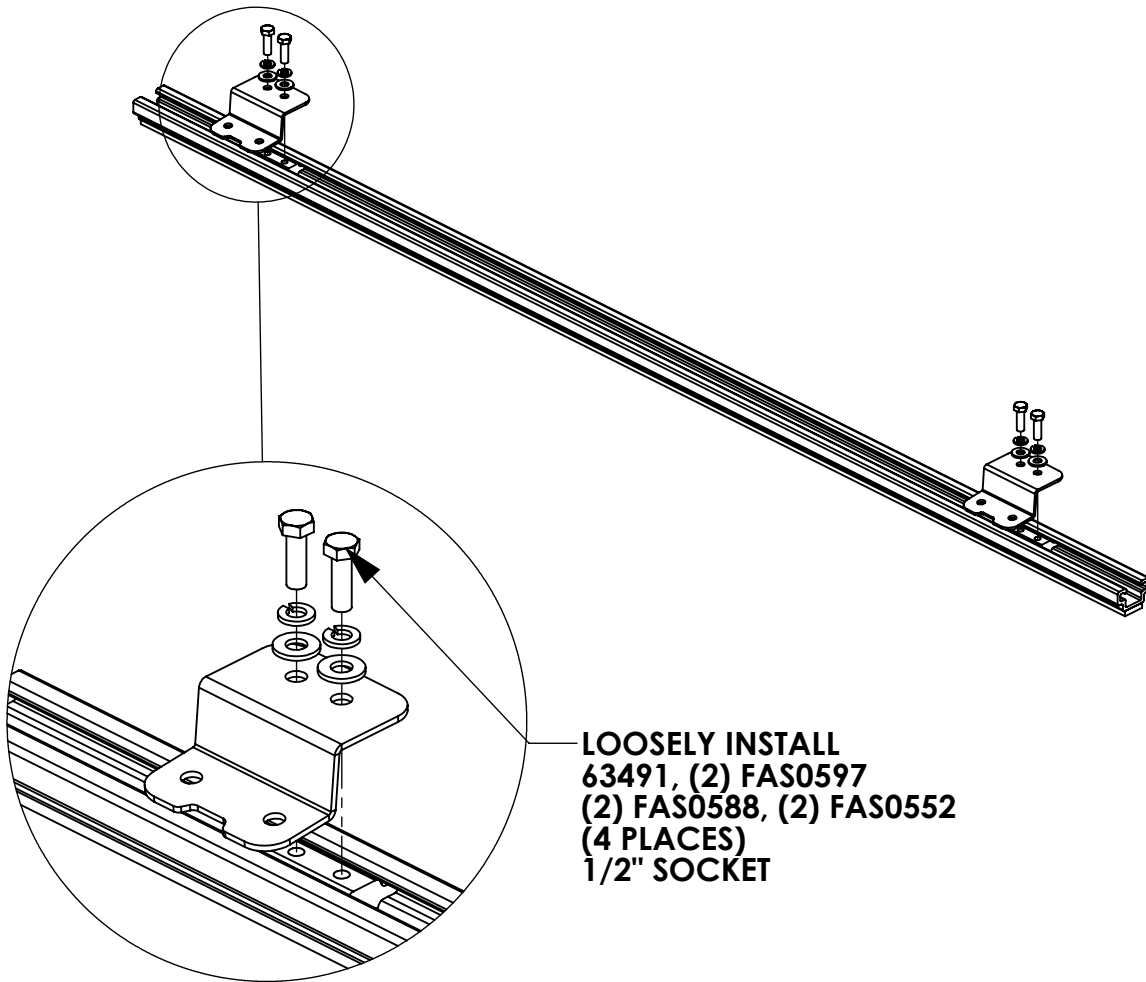

**STEP 2 - MARK AND DRILL HOLES TO MOUNT RAILS**

LOCATE THE REINFORCEMENT PLATES ON BOTH SIDES OF TOPPER (FRONT AND REAR).

MOUNTING HOLES IN RAIL BRACKETS NEED TO BE ABOVE THESE WHEN INSTALLED!!!

NOTE: INSIDE OF TOPPER SHOWN HERE

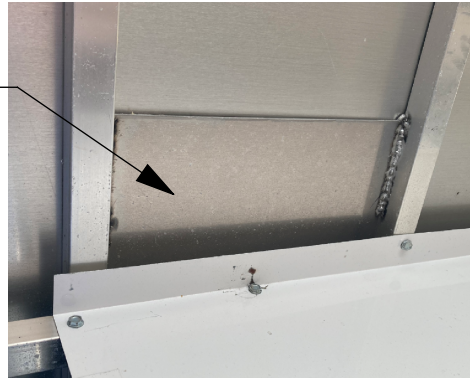

SET RAILS WITH BRACKETS ON ROOF, CENTER-TO-CENTER DISTANCE OF RAILS MUST BE A MINIMUM OF 36 1/2", CENTERED ON THE TOPPER.

IF INSTALLING THE 55" ROOF RAIL KIT ON A FORD MAVERICK, THIS DIMENSION SHOULD BE APPROXIMATELY 28 5/8".

PLEASE ENSURE THE SPACING OF THE RAIL BRACKETS PROVIDE ENOUGH CLEARANCE FOR THE MOUNTING BRACKETS OF THE RACK TO BE INSTALLED. RACK SHOULD BE INSTALLED AS FAR REARWARD AS POSSIBLE. THE 4 5/8" DIMENSION IS A MINIMUM MEASUREMENT, BUT CAN BE MOUNTED ANYWHERE ALONG THE RAIL TO UTILIZE THE REINFORCEMENT PLATES

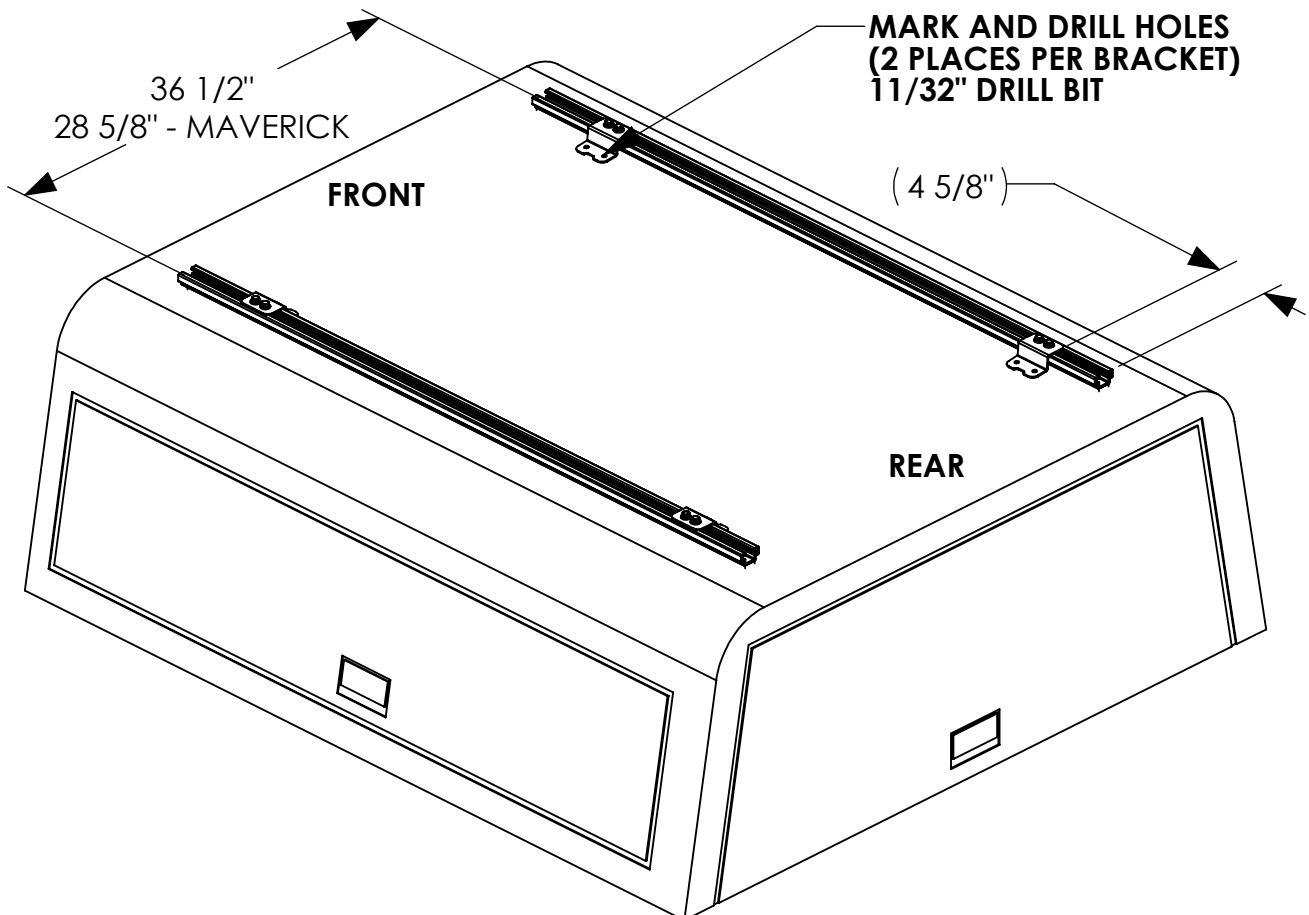

**STEP 3 - MOUNT RAILS TO TOPPER**

**NOTE: INSIDE OF TOPPER SHOWN HERE**

**POSITION PLATE TO ALLOW THE MOST SURFACE AREA OF THE PLATE TO CONTACT THE WELDED REINFORCEMENT PLATES.**

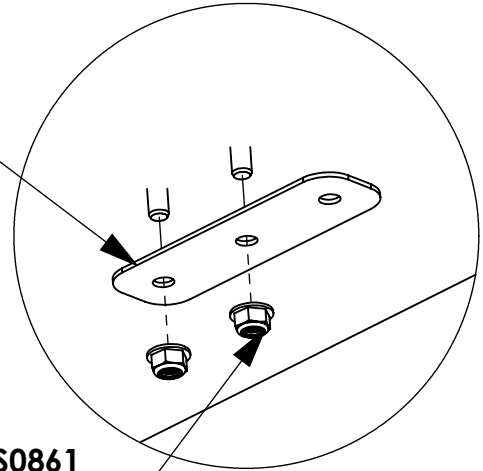

**FAS0830, FAS0552, FAS0861  
(2 PLACES PER BRACKET)  
1/2" SOCKET  
1/2" WRENCH**

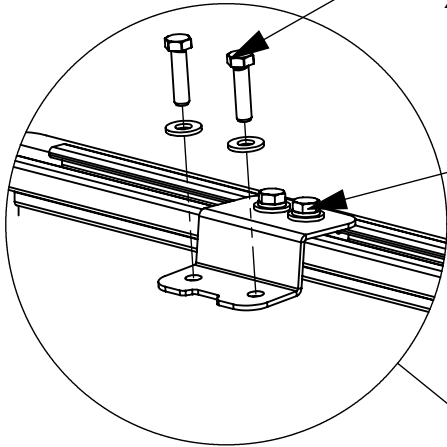

**FULLY TIGHTEN BOLTS  
(2 PLACES PER BRACKET)  
1/2" SOCKET**

**POKE FASTENERS THROUGH FOAM TAPE.  
APPLY SILICONE AROUND DRILLED HOLES!**

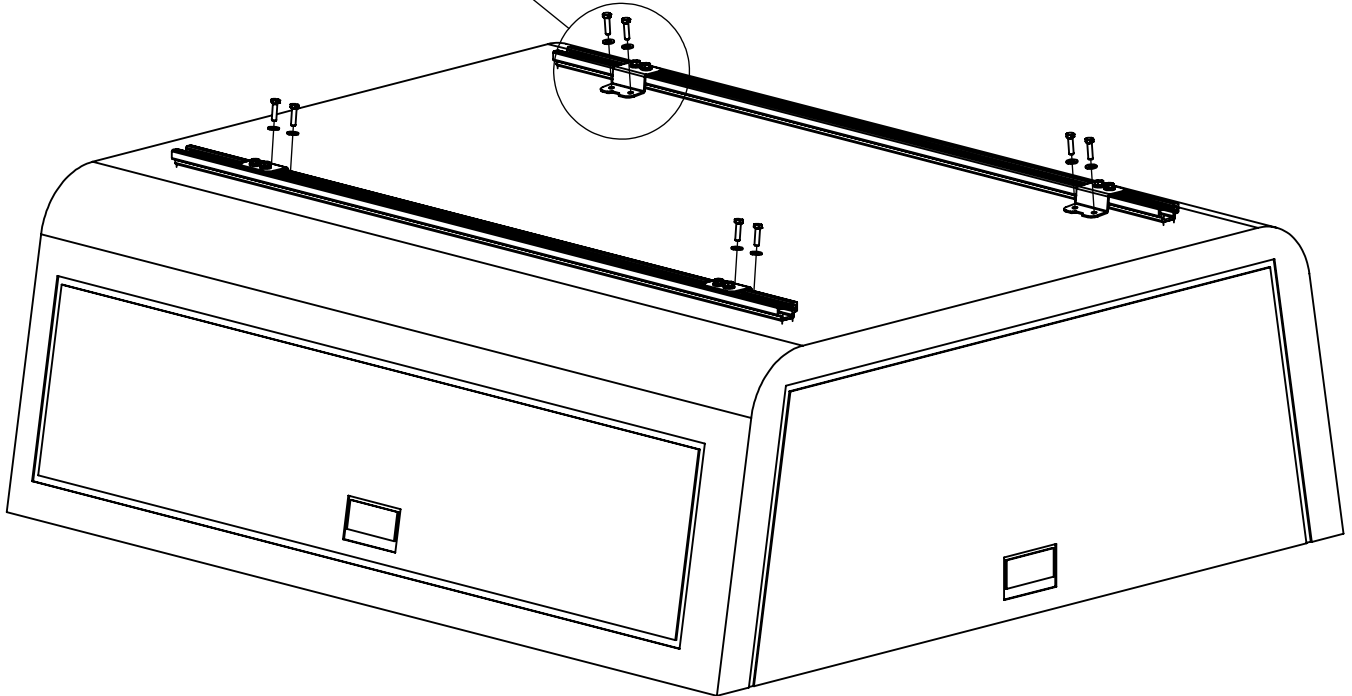



## 2-Crossbar Kit, 48", Black, Multiple Pickups



PRODUCT WEIGHT  
**13.4 LBS**

CROSSBOW LENGTH X  
HEIGHT

**49" x 2"**

CAPACITY

**REFER TO OEM'S  
RECOMMENDED LOAD  
RATING**

COLOR

**BLACK**

CATALOG NUMBER

**2BARTOPB**

### PRODUCT FEATURES

Aluminum base 2-crossbow kit for PROFILE™ HD Utility, Grip-Lock, ProLift, or combo ladder racks. Works with all ARE and Leer toppers for all cab styles and bed lengths. Works with and without OEM specific rail kit and generic mounting bracket kits.

Additional crossbows and optional uprights, conduit kits, and rear rollers available.

Utility and grip lock ladder racks are not recommended for medium and high roof vehicles!

Please refer to OEM specific mounting kit or rail kit for additional information on compatible accessories.

# INSTALLATION GUIDE FOR PROFILE™ SERIES LADDER RACKS

INSTRUCTION #:  
**68895**

REV:  
**B**

THIS INSTRUCTION PROVIDES A GENERAL GUIDE OF INSTALLATION SEQUENCE FOR ALL PROFILE™ SERIES LADDER RACKS. PLEASE ENSURE ALL ACCESSORIES ARE INSTALLED PER TYPE OF RACK BEFORE PROCEEDING TO NEXT PAGE.

REFERENCE THIS INSTRUCTION THROUGHOUT THE ENTIRETY OF YOUR INSTALL TO PREVENT ACCESSORIES BEING INSTALLED INCORRECTLY/OUT OF SEQUENCE!

STEPS 21 - 81 ON PAGE 3 IS THE RECOMMENDED ASSEMBLY SEQUENCE FOR A FULL TABLE ASSEMBLY BEFORE INSTALLING ON THE ROOF OF THE VEHICLE.

STEPS 2R - 8R ON PAGE 4 IS AN ALTERNATE ASSEMBLY SEQUENCE TO INSTALL THE RACK ON THE VEHICLE ROOF AS IT IS BUILT.

PLEASE SELECT THE ASSEMBLY SEQUENCE THAT BEST WORKS FOR YOU!

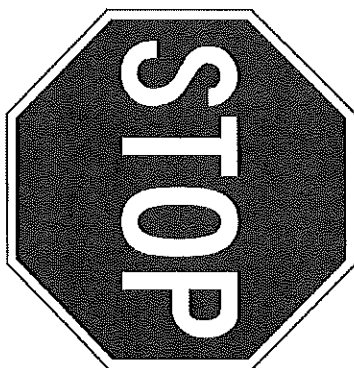

## ASSEMBLY STEPS:

**STEP 1A. SUB-ASSEMBLE EACH CROSSBOW WITH DESIRED ACCESSORIES FOR SECTIONS A.1 & A.2.**

*INSTRUCTIONS FOR EACH KIT CAN BE FOUND IN THEIR RESPECTIVE CARTON!*

TOP OF CROSSBOW \*IMAGE NOT TO SCALE!

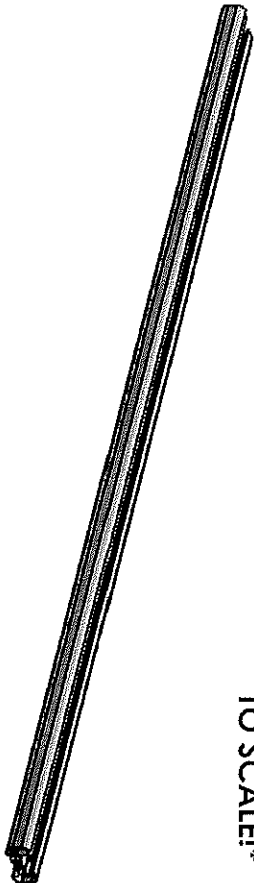

BOTTOM OF CROSSBOW

**TABLE 1**

TOP OF CROSSBOW		COMPONENTS TO INSTALL
A.1		HD UTILITY - CONDUIT KIT OR BEACON
		Grip-Lock - CONDUIT KIT OR BEACON
		ProLift - CONDUIT KIT OR BEACON
BOTTOM OF CROSSBOW		COMPONENTS TO INSTALL
A.2		HD UTILITY - LADDER STOP, STROBE BRACKET, AND/OR REAR ROLLER
		Grip-Lock - Grip-Lock SUB-ASSEMBLY
		ProLift - DAMPER BRACKET

**STEP 1B. SUB-ASSEMBLE EACH CROSSBOW WITH DESIRED ACCESSORIES FOR SECTIONS B.1 & B.2. INSTRUCTIONS FOR EACH KIT CAN BE FOUND IN THEIR RESPECTIVE CARTON!**

**TOP OF CROSSBOW**

**\*IMAGE NOT TO SCALE!\***

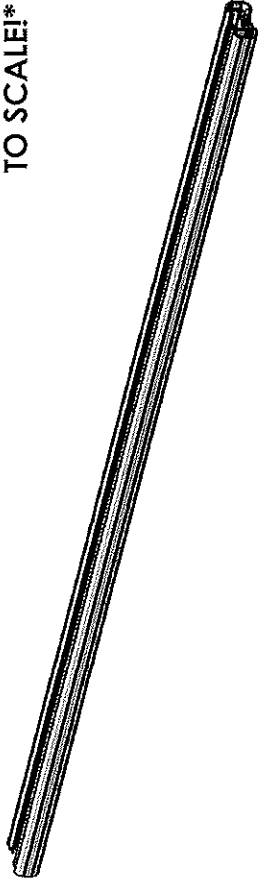

**BOTTOM OF CROSSBOW**

**TABLE 2**

TOP OF CROSSBOW	
	COMPONENTS TO INSTALL
HD UTILITY	- WEAR STRIP (MODIFY IF NECESSARY, TABLE 3)
Grip-Lock	- WEAR STRIP (MODIFY IF NECESSARY, TABLE 3)
ProLift	- INNER STOP POST
BOTTOM OF CROSSBOW	
	COMPONENTS TO INSTALL
HD UTILITY	- MOUNTING BRACKETS
Grip-Lock	- MOUNTING BRACKETS
ProLift	- MOUNTING BRACKETS

**ALTER WEAR STRIP AND INSTALL ON CROSSBOW (IF APPLICABLE)! REFERENCE TABLE 3 BELOW FOR WEAR STRIP ALTERATION INSTRUCTIONS!**

**TABLE 3**

ADDED ACCESSORIES	ALTERATION FOR WEAR STRIP
4" UPRIGHT***	REMOVE 2" FROM END OF WEAR STRIP
4" PVC CONDUIT KIT	REMOVE 7.25" FROM CENTER OF WEAR STRIP
6" PVC CONDUIT KIT	REMOVE 9.50" FROM CENTER OF WEAR STRIP
ALUMINUM BOX CONDUIT KIT	REMOVE 13.25" FROM CENTER OF WEAR STRIP
BEACON	REMOVE 4" FROM CENTER OF WEAR STRIP
ProLift (SINGLE SIDE)	CUT WEAR STRIP IN HALF, DO NOT INSTALL ON ProLift SIDE
ProLift (DUAL SIDE)	DO NOT INSTALL WEAR STRIP

**SLIDE WEAR STRIP INTO RAIL AND CENTER (1 PER CROSSBOW)**

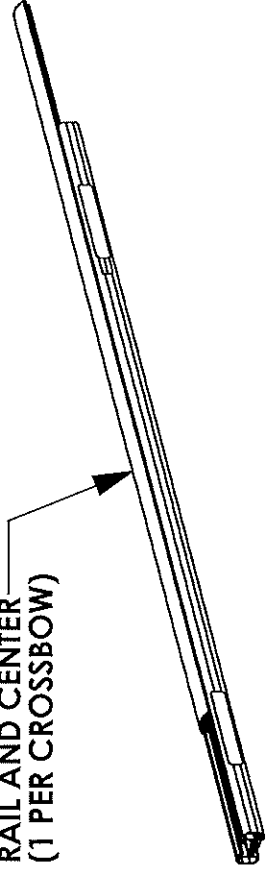

**STEP 1C SUB-ASSEMBLE EACH CROSSBOW WITH DESIRED ACCESSORIES FOR SECTIONS C.1 & C.2**

TOP OF CROSSBOW  
\*IMAGE NOT TO SCALE!\*

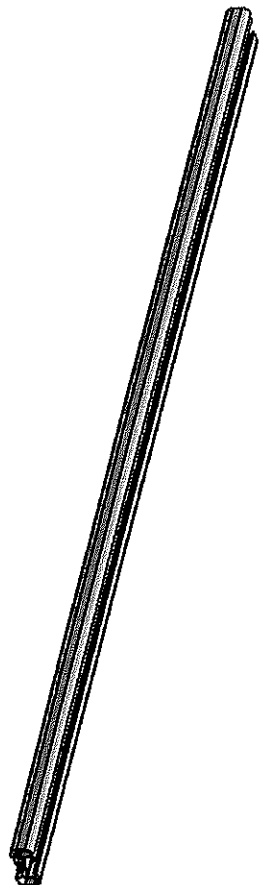

BOTTOM OF CROSSBOW

**TABLE 4**

TOP OF CROSSBOW COMPONENTS TO INSTALL	
HD UTILITY	- 4" UPRIGHT
Grip-Lock	- N/A
Prolift	- SLIDES FOR BASE EXTRUSION
BOTTOM OF CROSSBOW COMPONENTS TO INSTALL	
HD UTILITY	- UPRIGHTS (6", 9", RATCHET)
Grip-Lock	- STROBES
Prolift	- STROBES

**ASSEMBLY STEPS (FULL BENCH ASSEMBLY):**

- 2T. ADD DRIVELINES (IF INSTALLING Prolift)
- 3T. ADD HANDLES (IF INSTALLING Grip-Lock OR Prolift) AND DAMPERS (IF INSTALLING Prolift)
- 4T. ADD OUTER SUPPORT BARS (IF INSTALLING Grip-Lock OR Prolift)
- 5T. ADD STEP LADDER KIT (Grip-Lock OR Prolift ONLY)

6T. ASSEMBLE ENDS CAPS TO CROSSBOW

USED FOR HD UTILITY & Grip-Lock RACKS

LOCATED IN CROSSBOW KIT

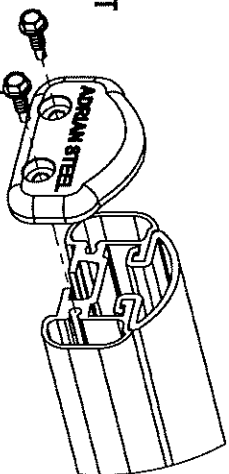

FULLY TIGHTEN  
(2) FAS0473, 63851  
(2 PLACES PER END CAP)  
5/16" SOCKET

USED FOR Prolift RACKS  
LOCATED IN Prolift Kit

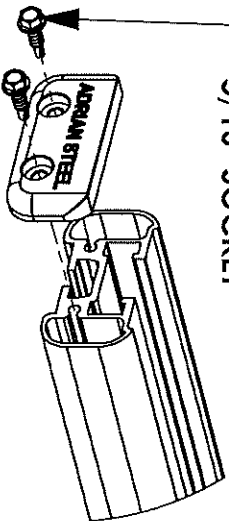

7T. INSTALL ROOF RAIL KIT ON VEHICLE ROOF OR BOTTOM MOUNTING BRACKETS

(ROOF RAIL KIT REQUIRED FOR Grip-Lock & Prolift OPTIONAL FOR HD UTILITY, NOT NEEDED FOR GM LADDER RACKS)

8T. MOUNT CROSSBOW SUB-ASSEMBLIES FROM STEP 1 TO VEHICLE/MOUNTING BRACKET, OR ROOF RAIL (LOOSE INSTALL)



**ALTERNATE ASSEMBLY METHOD!**  
**(ASSEMBLE ON VEHICLE ROOF):**

- 2R. INSTALL ROOF RAIL KIT ON VEHICLE ROOF OR BOTTOM MOUNTING BRACKETS  
(ROOF RAIL KIT REQUIRED FOR Grip-Lock & ProLift, OPTIONAL FOR HD UTILITY, NOT NEEDED FOR GM LADDER RACKS)
- 3R. MOUNT CROSSBOW SUB-ASSEMBLIES FROM STEP 1 TO VEHICLE/MOUNTING BRACKET, OR ROOF RAIL (LOOSE INSTALL)
- 4R. ADD DRIVELINES (IF INSTALLING ProLift)
- 5R. ADD HANDLES (IF INSTALLING Grip-Lock OR ProLift) AND DAMPERS (IF INSTALLING ProLift)
- 6R. ADD OUTER SUPPORT BARS (IF INSTALLING Grip-Lock OR ProLift)
- 7R. ADD STEP LADDER KIT (Grip-Lock OR ProLift ONLY!)

8R. ASSEMBLE END CAPS TO CROSSBOW

USED FOR HD UTILITY & Grip-Lock RACKS

LOCATED IN CROSSBOW KIT

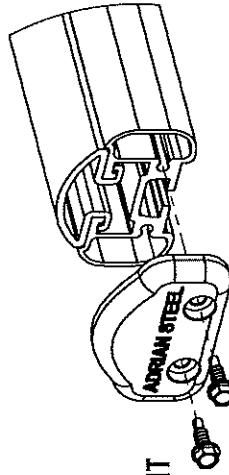

FULLY TIGHTEN  
(2) FAS0473, 63851  
(2 PLACES PER END CAP)  
5/16" SOCKET

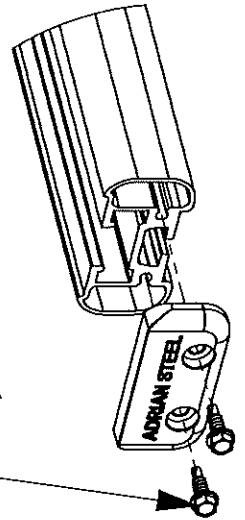

USED FOR ProLift RACKS  
LOCATED IN ProLift Kit