

INSTR. NUMBER : 67116	PG: 1	REV: C	ITEM NO.	PART NUMBER	DESCRIPTION	GL-FSVDS	GL-FSVPS
PART NUMBER • GL-FSVDS PART NUMBER • GL-FSVPS			1	66358	GRIP LOCK FRONT STOP ASSM	1	1
			2	27254-B	SLEEVE-HORN,L.R. BLACK	1	1
PART • GL FULL SIZE VEHICLE DS DESC. • GL FULL SIZE VEHICLE PS			3	66293	GRIP LOCK OUTER TUBE	1	1
			4	66357	GRIP LOCK HANDLE CLAMP POST	1	1
NOTE: THIS INSTRUCTION IS VALID FOR THE FOLLOWING KITS:			5	69445	GRIP LOCK FSV, ASM DS	1	-
			6	69444	GRIP LOCK FSV, ASM PS	-	1

NOTE: 66357, 69444, & 69445 ARE AVAILABLE IN BLACK VARIANTS - FOR THEIR IDENTIFICATION, ADD THE "-B" SUFFIX TO THE END OF THE PART NUMBER

- GL-FSVDS
- GL-FSVPS
- GL-FSVPSB
- GL-FSVDSB

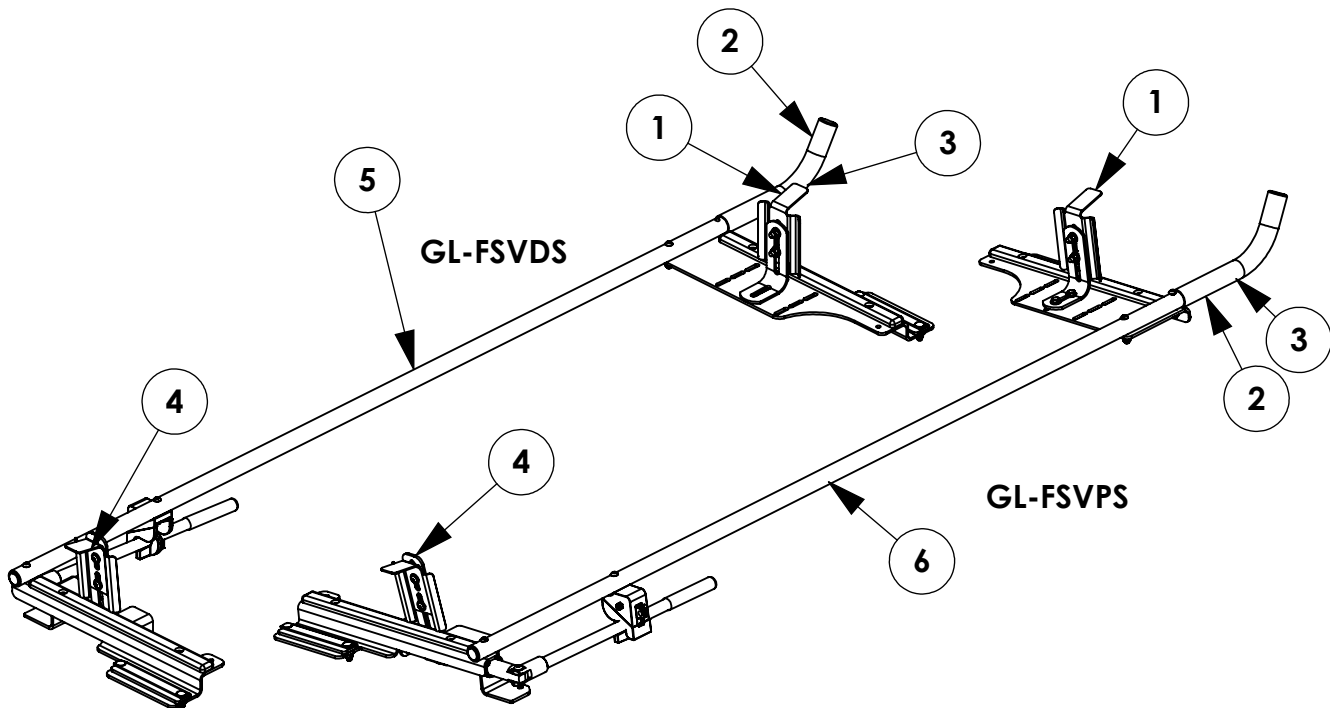

****IF BUILDING A DUAL SIDED RACK BUILD BOTH SIDES IN PARALLEL FOR EACH STEP. IF BUILDING SINGLE SIDED REFERENCE ONLY THAT SIDE WHEN BUILDING.****

TOOLS NEEDED:
 1/2" SOCKET
 1/2" WRENCH
 9/16" SOCKET
 3/16" ALLEN WRENCH
 DRIVE RATCHET
 IMPACT DRIVER

GET TO KNOW THE VEHICLE - AT THE BEGINNING OF ANY INSTALLATION, CHECK THE LOCATION OF THE FUEL TANK, FUEL LINES, BRAKE LINES, HIGH VOLTAGE BATTERIES AND WIRING HARNESSSES TO AVOID INJURY OR PROPERTY DAMAGE FROM TOOL CONTACT.

SEAL ALL EXTERIOR HOLES - ALL INSTALLATION HOLES SHOULD BE SEALED WITH BUTYL TAPE OR SILICON TO PREVENT WATER AND EXHAUST GASES FROM ENTERING THE VEHICLE.

CONTROL DRILL DEPTH - TO AVOID DAMAGE TO THE VEHICLE, USE A DRILL STOP OR CLEARED STEP BIT WHEN DRILLING INSTALLATION HOLES.

ALWAYS ADD PRIMER - WHEN ADDING INSTALLATION HOLES BE SURE TO USE A SELF-ETCHING PRIMER TO PREVENT CORROSION, FASTENER FAILURE AND INJURY.

MOUNTING POINTS MUST HAVE METAL-TO-METAL CONTACT - USE PROVIDED MOUNTING SPACERS TO ACCOMMODATE FOR VEHICLE FEATURES, CARPET OR SUBFLOORS.

PROVIDE CLEARANCE FOR SPACERS - IF THE INSTALLATION VEHICLE CONTAINS A CARPET OR SUBFLOOR, USE A 1-3/16" DIAMETER CARPET CUTTER (P/N: 31183-0) AT ALL MOUNTING LOCATIONS TO OPEN UP ROOM FOR SPACERS.

CHECK SPACER ORIENTATION - BE SURE THAT THE INDENT IN THE SPACER COVERS THE PLUSNUT HEAD; THIS ENSURES THE MOST METAL-TO-METAL CONTACT AND REDUCES VIBRATION.

PLUSNUT INSTALLATION - A PLUSNUT GUN IS RECOMMENDED FOR PLUSNUT INSTALLATION FOR ITS PRODUCTION SPEED. HOWEVER, A PLUSNUT SETTING TOOL CAN ALSO BE USED (P/N: 22200-0).

THRU-BOLT CLEARANCE - WHEN USING A THRU-BOLT AT ANY MOUNTING LOCATION, BE SURE THAT YOUR HOLE HAS 1/16" CLEARANCE.

FASTENERS USED

BAG REFERENCE: BAG66374

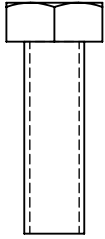

FAS0597
SCREW, HH SS
5/16-18X1.00
SINGLE QTY: 2

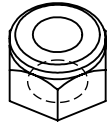

FAS0248
NUT, HEX NLK
5/16-18 SS
SINGLE QTY: 3

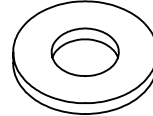

FAS0552
WASHER, FLAT
5/16 USS SS
SINGLE QTY: 5

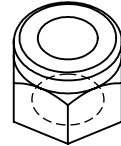

FAS0110
NUT, HEX NLK
3/8-16 SS
QTY: 1

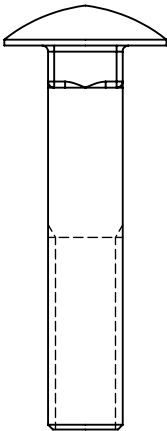

FAS0721
BOLT, CRG SS
3/8-16X2.00
QTY: 1

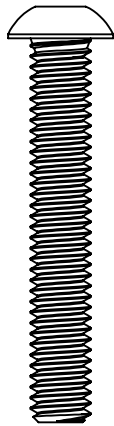

FAS0841
SCRW, BHCS SS
5/16-18X2.0
QTY: 1

FOR DUAL SIDED RACK DOUBLE FASTENER QUANTITY

INTENTIONALLY LEFT BLANK



SHIP THRU FINAL DEALER ASSEMBLY

IF NOT RECEIVING SHIP THRU RACK SKIP TO STEP 2

STEP 1 SLIDE RACK OUT FROM SHIP THRU MODE

STEP 1.1
LOOSEN FAS0248
(04 PLACES PER SIDE)
1/2" WRENCH

STEP 1.2
SLIDE RACK
OUTWARDS UNTIL
GRIP LOCK
TOUCHES
MOUNTING FEET

STEP 1.3
FULLY TIGHTEN
FAS0248
(04 PLACES PER SIDE)
1/2" WRENCH

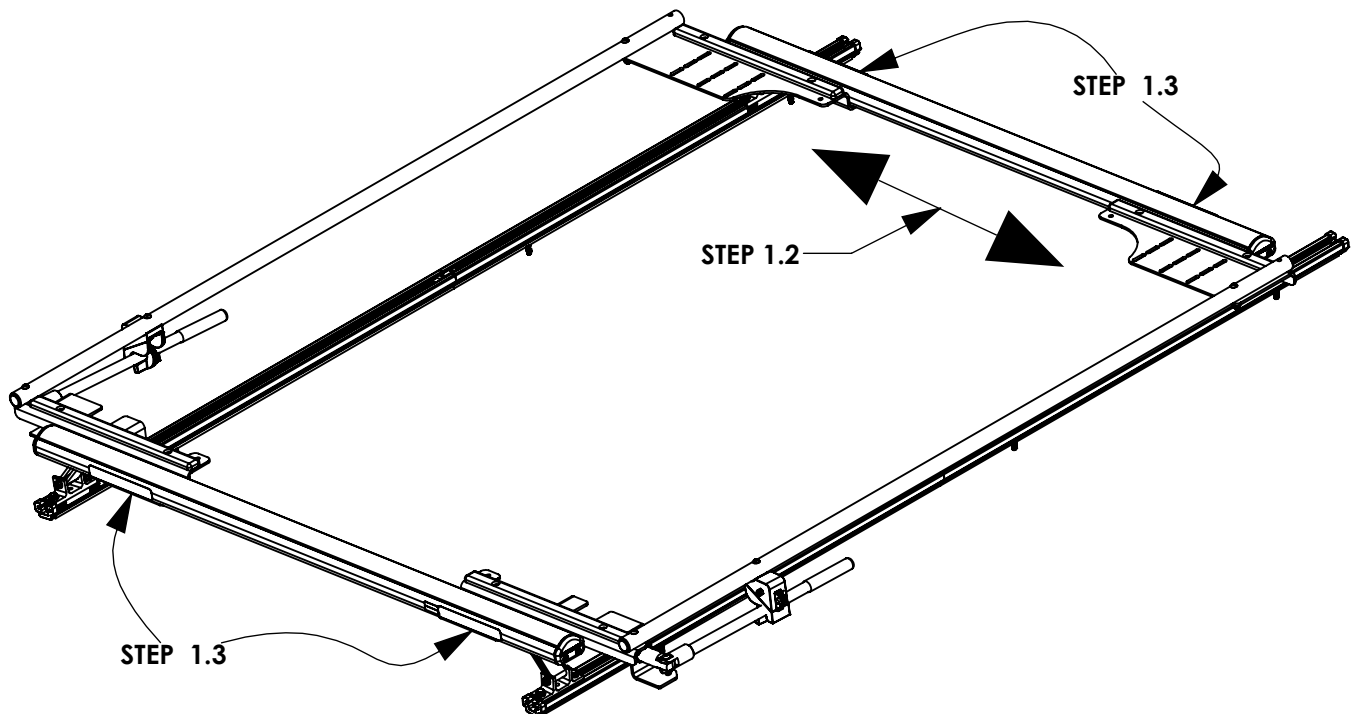
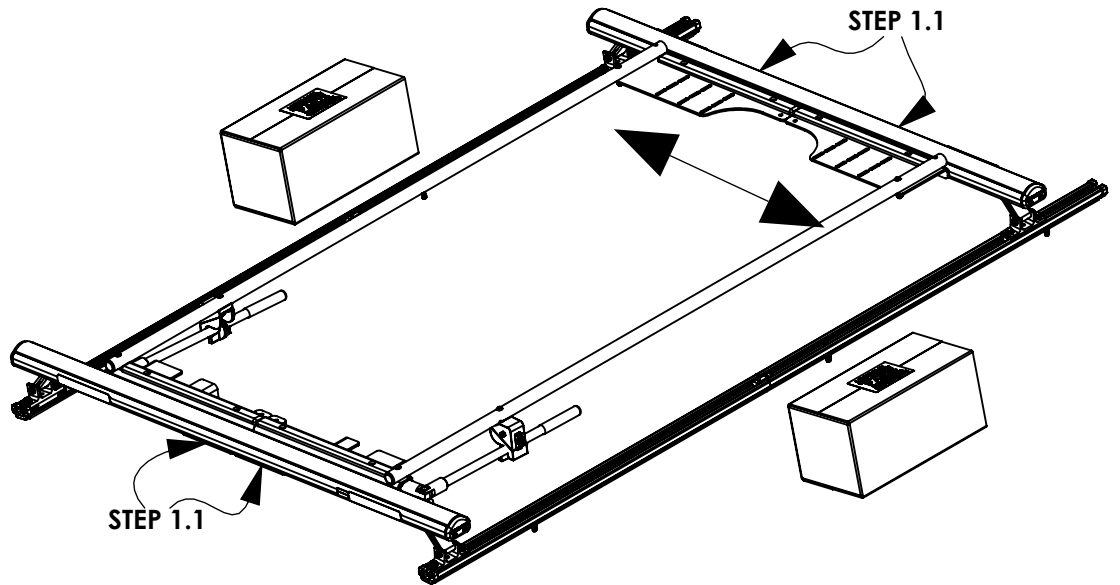

STEP 2 -ASSEMBLE HANDLE POST TO REAR BRACE ASSEMBLY

STEP 2.1
FULLY TIGHTEN
FAS0721 AND
FAS0110
9/16" WRENCH

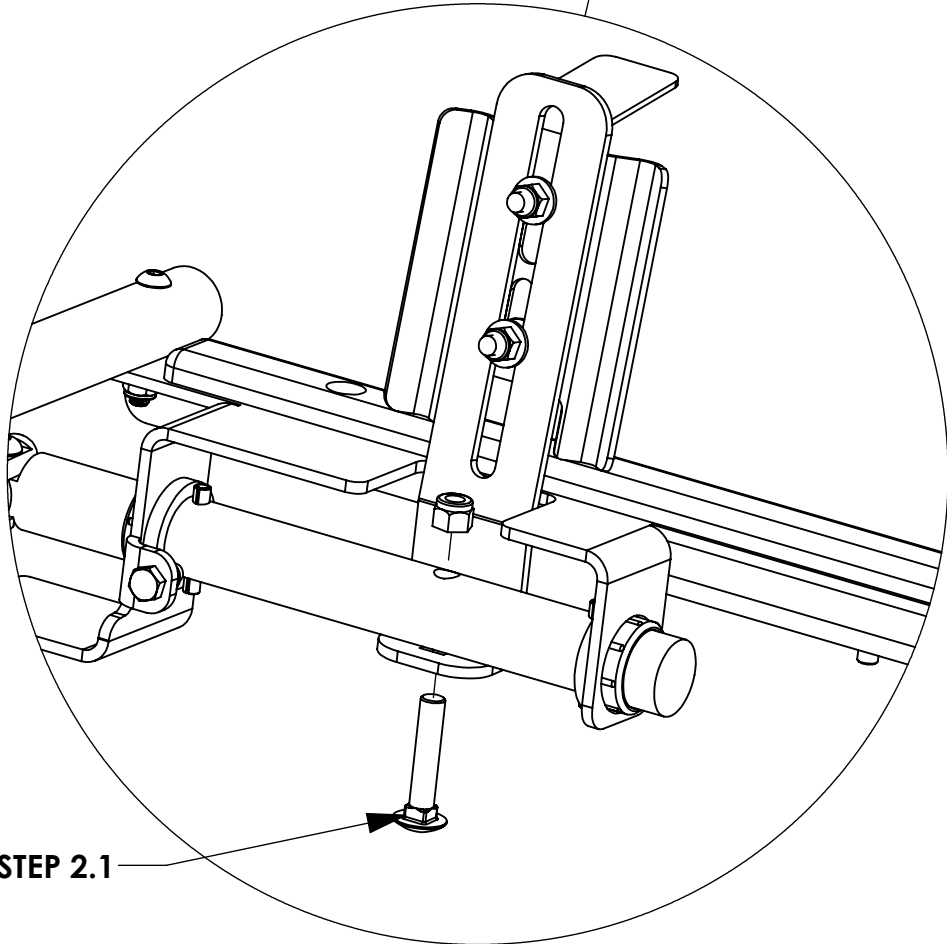
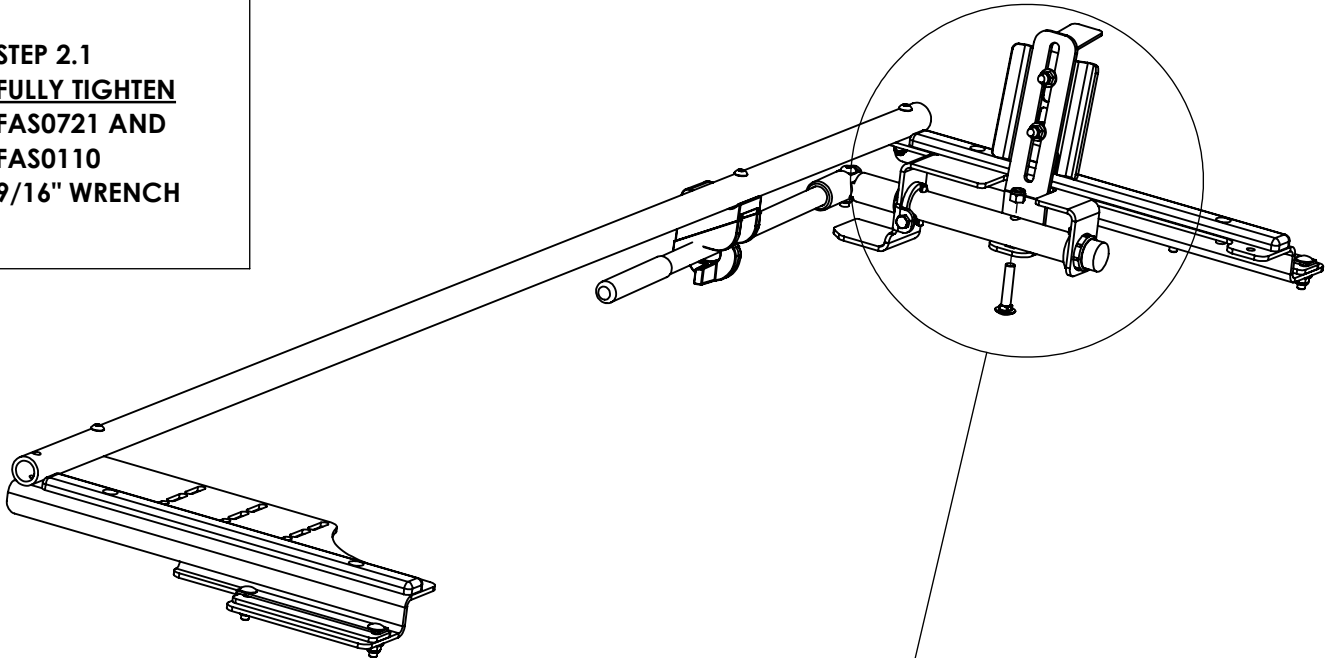

STEP 2.1

7 STEP 3 - ASSEMBLE FRONT STOP AND HORN

STEP 4.1
FULLY TIGHTEN
FAS0841, FAS0552,
FAS0248
3/16 ALLEN
1/2 WRENCH

STEP 4.2
FULLY TIGHTEN
FAS0597, (2)
FAS0552,
AND FAS0248
(2 PLACES)
1/2 WRENCH
1/2 SOCKET

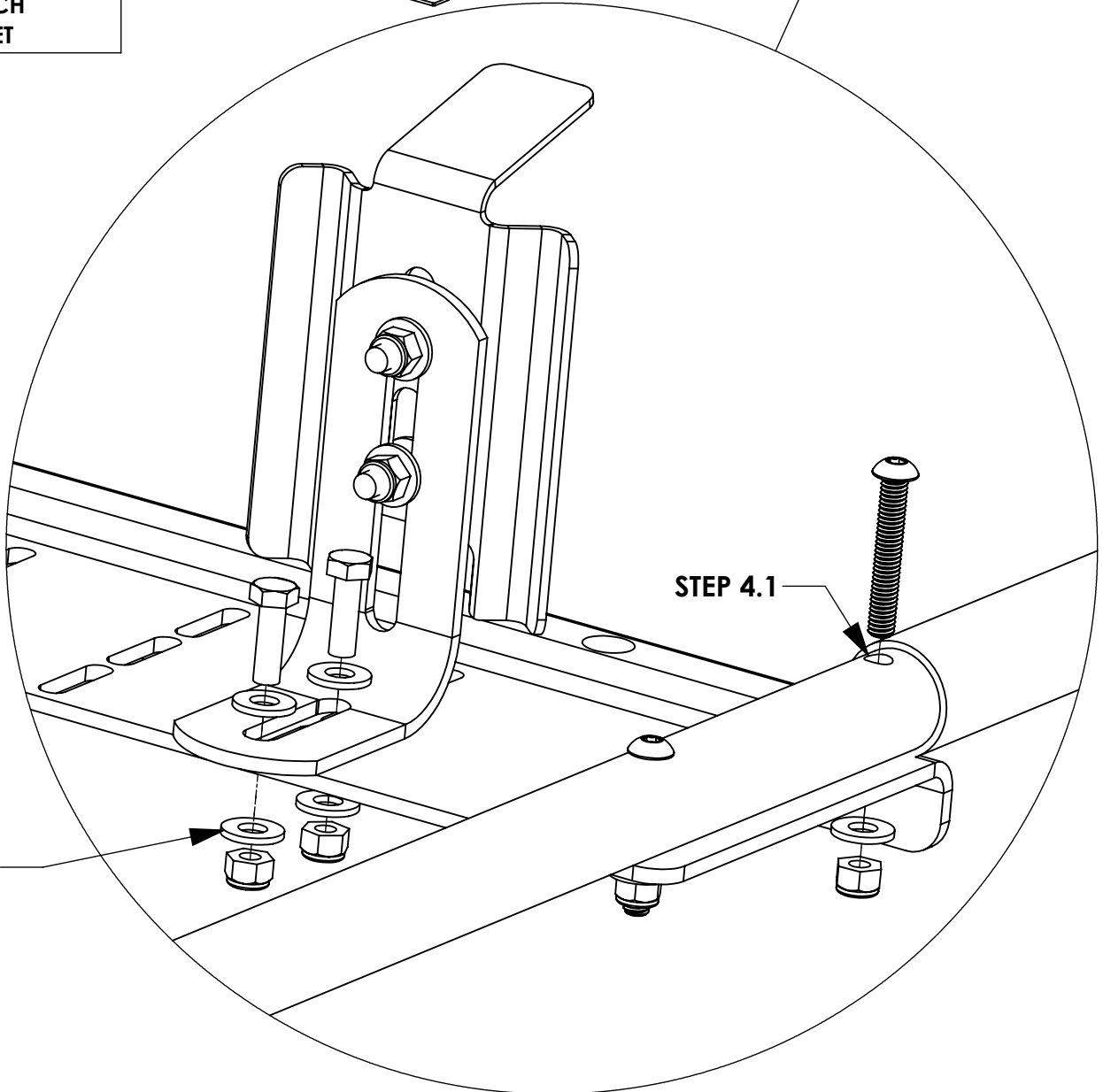
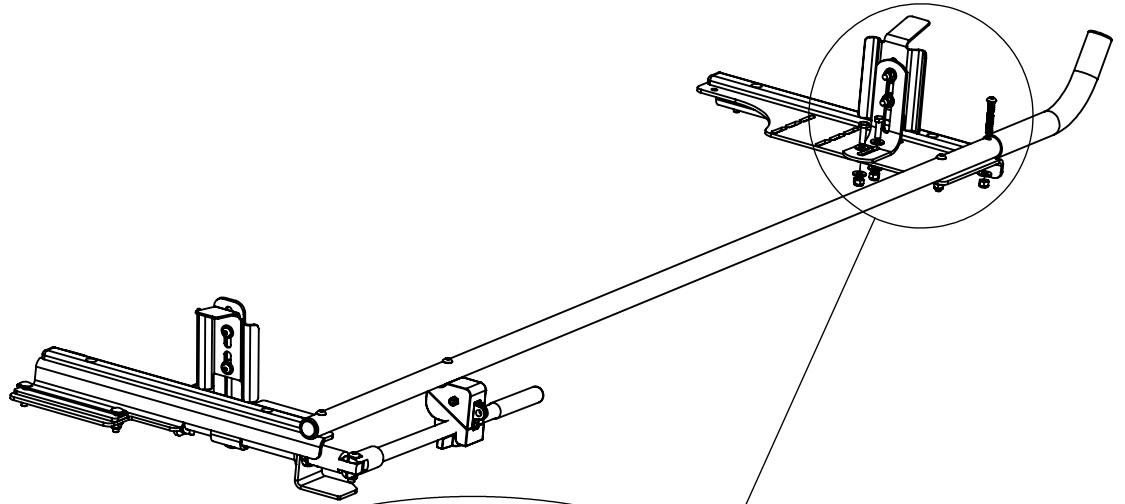

STEP 4.1

STEP 4.2

STEP 4 - INSTALL GRIP LOCK INTO CROSSBOW

IF SHIP THRU FINAL DEALER SKIP THIS STEP. RACK IS ALREADY ON VEHICLE

STEP 5.1 **B.2**
SLIDE GRIP LOCK
INTO CROSSBOW

LEAVE FASTENERS
LOOSE FOR
ADJUSTING RACK
ONCE ON VEHICLE

STEP 5.2
INSTALL MOUNTING
FEET ONTO
CROSSBOW
(REFERENCE
MOUNTING KIT
INSTRUCTIONS)

STEP 5.3
SLIDE GRIP LOCK
OUT SO IT IS
TOUCHING
MOUNTING FEET AND
FULLY TIGHTEN
FASTENERS

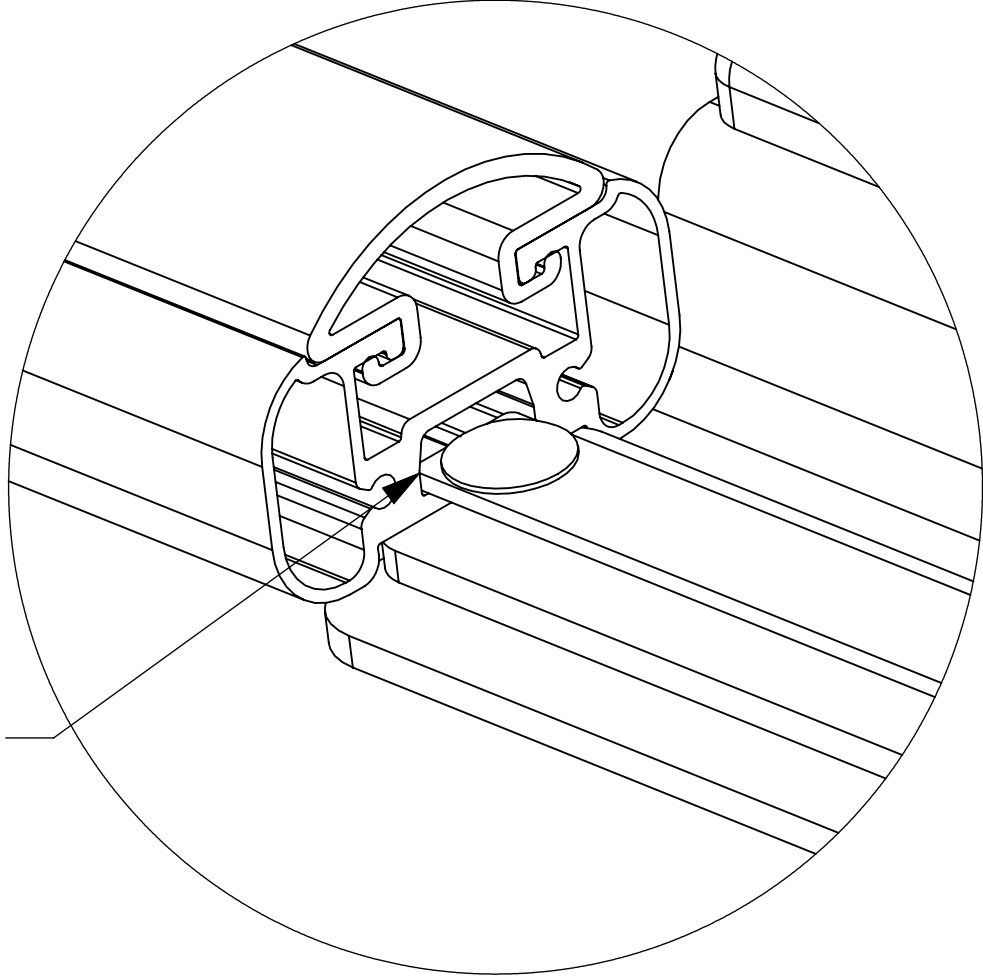
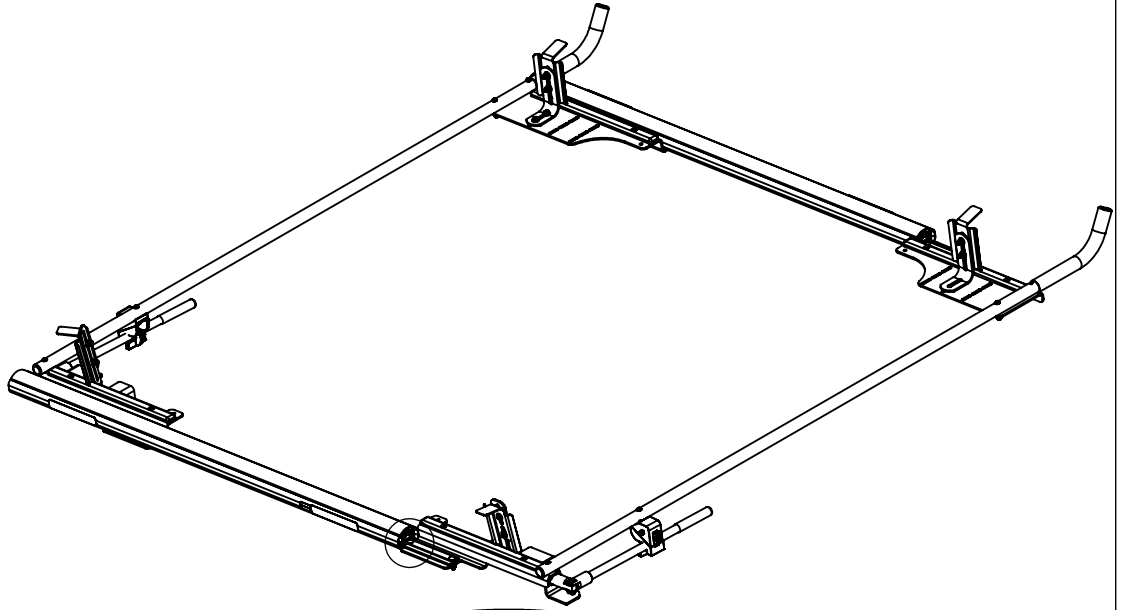

Step 5.1

GRIP LOCK INSTALLATION IS COMPLETE!!!



Passenger Side Grip-Lock Kit, Full Size Van



PRODUCT WEIGHT
37.7 LBS

WIDTH x DEPTH x HEIGHT
22" x 88" x 11"

CAPACITY
N/A

COLOR
WHITE/BLACK

CATALOG NUMBER
GL-FSVPS

PRODUCT FEATURES

Passenger side kit for PROFILE™ Grip-Lock and combo ladder racks. Works with all conduit kits.

Works on GM Express/Savana, Ford Transit Low Roof, and Nissan NV Low Roof vans. Not recommended for Medium Roof, High Roof, Ram Promaster Low Roof, or Mercedes Sprinter Low Roof vans.

Please refer to OEM specific mounting kit or rail kit for additional information on compatible accessories.

SEE PAGE 2 FOR APPLICATION NOTES AND ACCESSORIES, OTHER PRODUCTS THAT WORK WITH THIS UNIT.

PAGE 1 of 2

The information contained in this document is the sole property of ADRIAN STEEL COMPANY. ADRIAN STEEL COMPANY retains the right to modify and/or change the product of its design at any time without prior notification.



CATALOG NUMBER GL-FSVPS

PRODUCT APPLICATION

Passenger side kit for PROFILE™ Grip-Lock and combo ladder racks. Works with all conduit kits. Works on GM Express/Savana, Ford Transit Low Roof, and Nissan NV Low Roof vans. Not recommended for Medium Roof, High Roof, Ram Promaster Low Roof, or Mercedes Sprinter Low Roof vans.

ACCESSORIES THAT WILL WORK WITH THIS PRODUCT

CATALOG NUMBER	DESCRIPTION
2BARW	2-Crossbar Kit, 68”, White, Full Size Van
2BARCW	2-Crossbar Kit, 58”, White, Minivan
1BARW	Single Crossbar Kit, 68”, White, Full Size Van
1BARCW	Single Crossbar Kit, 58”, White, Minivan

INSTR. NUMBER : 70691	PG: 1	REV: B	ITEM NO.	PART NUMBER	DESCRIPTION	GL-FSVDS	GL-FSVPS
PART NUMBER • GL-FSVDS • GL-FSVPS			1	69445	GRIP LOCK FSV, ASM DS	1	-
			2	69444	GRIP LOCK FSV, ASM PS	-	1
PART • GL FULL SIZE VEHICLE DS DESC. • GL FULL SIZE VEHICLE PS			3	66373	GRIP LOCK BRKTS & HORN	1	1

NOTE: THIS INSTRUCTION IS VALID FOR THE FOLLOWING KITS:

- GL-FSVDS
- GL-FSVPS
- GL-FSVPSB
- GL-FSVDSB

NOTE: 66357, 69444, & 69445 ARE AVAILABLE IN BLACK VARIANTS - FOR THEIR IDENTIFICATION, ADD THE "-B" SUFFIX TO THE END OF THE PART NUMBER

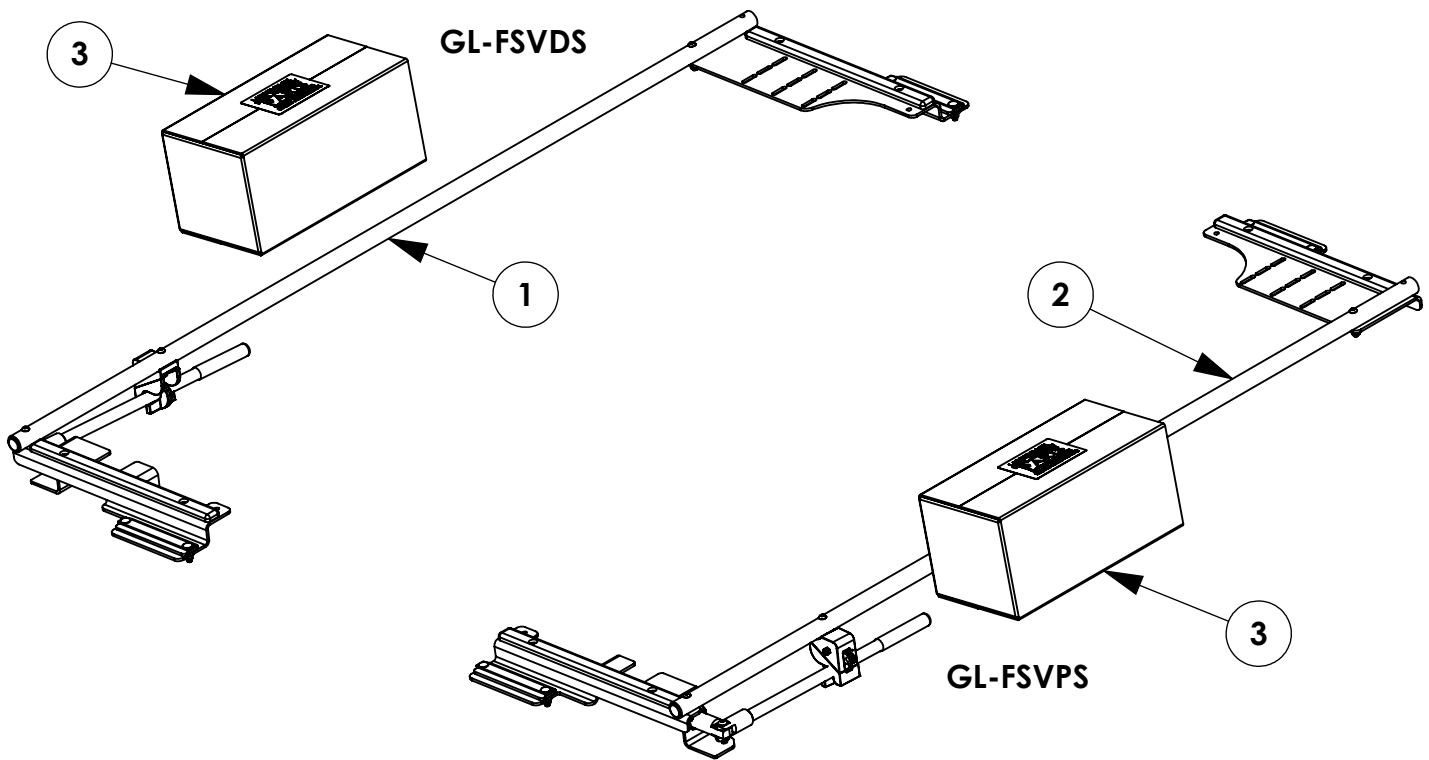

****IF BUILDING A DUAL SIDED RACK BUILD BOTH SIDES IN PARALLEL FOR EACH STEP. IF BUILDING SINGLE SIDED REFERENCE ONLY THAT SIDE WHEN BUILDING.****

TOOLS NEEDED:
 1/2" SOCKET
 1/2" WRENCH
 9/16" SOCKET
 3/16" ALLEN WRENCH
 DRIVE RATCHET
 IMPACT DRIVER

GET TO KNOW THE VEHICLE - AT THE BEGINNING OF ANY INSTALLATION, CHECK THE LOCATION OF THE FUEL TANK, FUEL LINES, BRAKE LINES, HIGH VOLTAGE BATTERIES AND WIRING HARNESSSES TO AVOID INJURY OR PROPERTY DAMAGE FROM TOOL CONTACT.

SEAL ALL EXTERIOR HOLES - ALL INSTALLATION HOLES SHOULD BE SEALED WITH BUTYL TAPE OR SILICON TO PREVENT WATER AND EXHAUST GASES FROM ENTERING THE VEHICLE.

CONTROL DRILL DEPTH - TO AVOID DAMAGE TO THE VEHICLE, USE A DRILL STOP OR CLEARED STEP BIT WHEN DRILLING INSTALLATION HOLES.

ALWAYS ADD PRIMER - WHEN ADDING INSTALLATION HOLES BE SURE TO USE A SELF-ETCHING PRIMER TO PREVENT CORROSION, FASTENER FAILURE AND INJURY.

MOUNTING POINTS MUST HAVE METAL-TO-METAL CONTACT - USE PROVIDED MOUNTING SPACERS TO ACCOMMODATE FOR VEHICLE FEATURES, CARPET OR SUBFLOORS.

PROVIDE CLEARANCE FOR SPACERS - IF THE INSTALLATION VEHICLE CONTAINS A CARPET OR SUBFLOOR, USE A 1-3/16" DIAMETER CARPET CUTTER (P/N: 31183-0) AT ALL MOUNTING LOCATIONS TO OPEN UP ROOM FOR SPACERS.

CHECK SPACER ORIENTATION - BE SURE THAT THE INDENT IN THE SPACER COVERS THE PLUSNUT HEAD; THIS ENSURES THE MOST METAL-TO-METAL CONTACT AND REDUCES VIBRATION.

PLUSNUT INSTALLATION - A PLUSNUT GUN IS RECOMMENDED FOR PLUSNUT INSTALLATION FOR ITS PRODUCTION SPEED. HOWEVER, A PLUSNUT SETTING TOOL CAN ALSO BE USED (P/N: 22200-0).

THRU-BOLT CLEARANCE - WHEN USING A THRU-BOLT AT ANY MOUNTING LOCATION, BE SURE THAT YOUR HOLE HAS 1/16" CLEARANCE.

PAGE:

3

***FASTENERS USED
BAG REFERENCE:***

**NO FASTENER BAG
ALL FASTENERS INCLUDED IN ASSEMBLY**

STEP 1 - INSTALL GRIP LOCK FOR SHIP THRU

STEP 1.1
SLIDE GRIP LOCK
INTO CROSSBOW

STEP 1.2
SLIDE RACKS ALL
THE WAY TO CENTER
OF CROSSBOW AND
FULLY TIGHTEN FOR
SHIP THRU
TRANSPORTATION
1/2" SOCKET

STEP 1.3
FULLY TIGHTEN
END CAPS
FAS0473, 63851
(02 PLACES PER END
CAP)
5/16" SOCKET

STEP 1.4
STORE PARTS BOX
66373 IN VEHICLE
FOR FINAL INSTALL
(1 BOX FOR SINGLE,
2 BOXES FOR
DOUBLE)

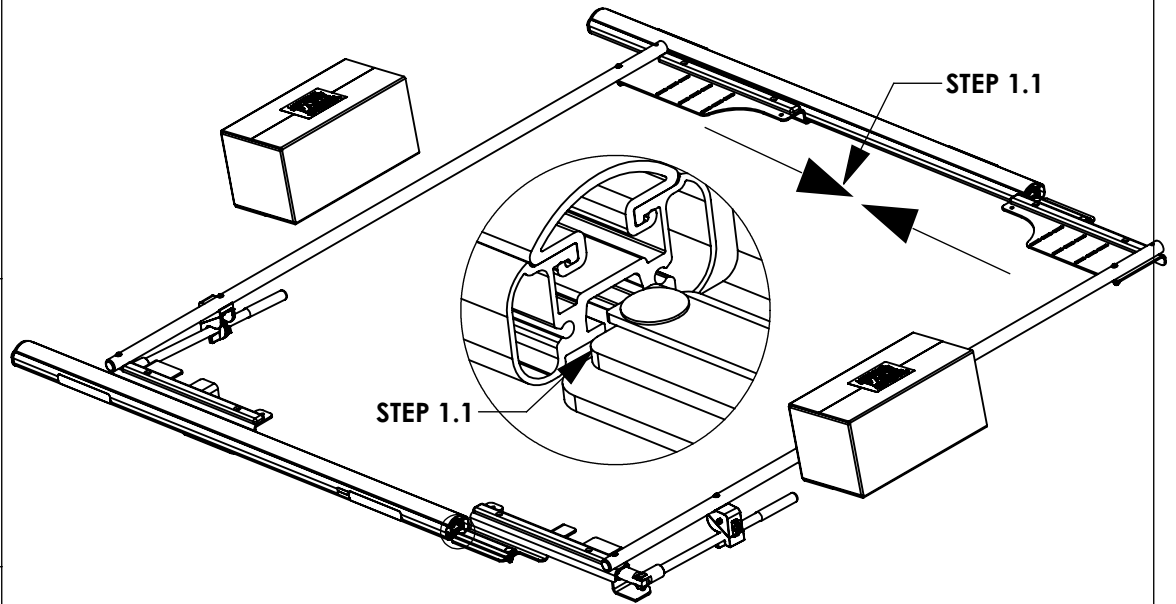

STEP 1.4
STORE PARTS BOX
66373 IN VEHICLE

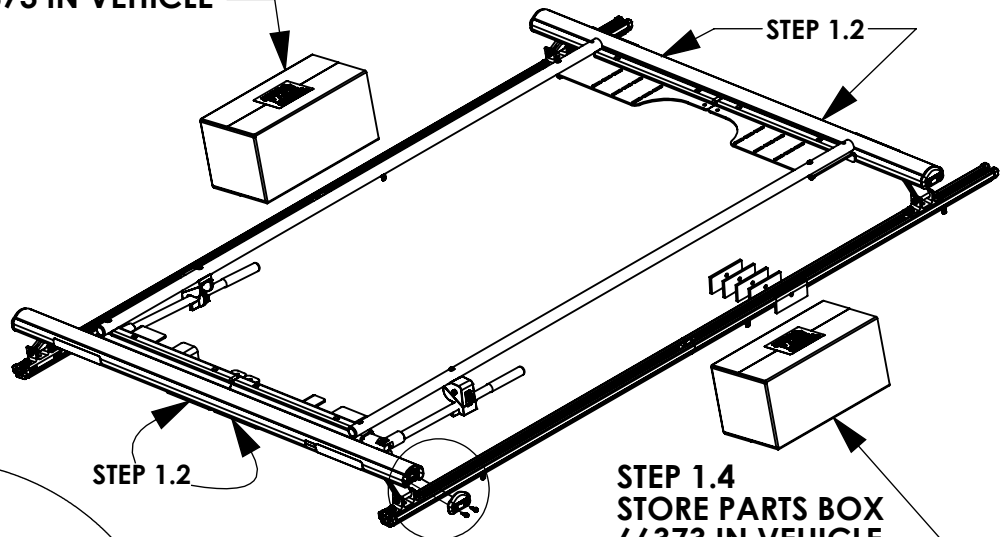

STEP 1.4
STORE PARTS BOX
66373 IN VEHICLE

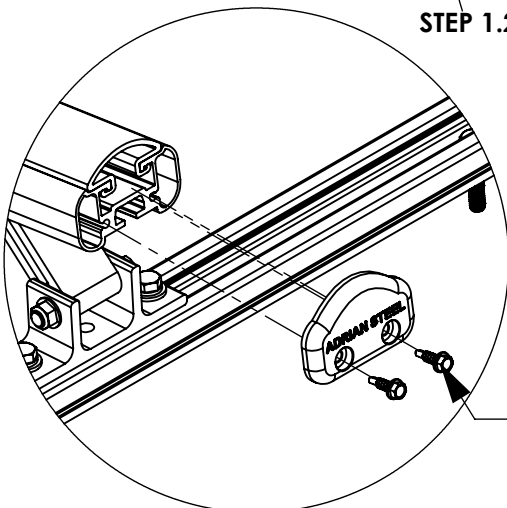

STEP 1.3

CHECK THAT ALL FASTENERS ARE TIGHTENED!!! INSTALLATION IS COMPLETE



Mounting Bracket Kit, 4-Pack, White, Express, Savana



PRODUCT WEIGHT
5 LBS

HEIGHT OFF ROOF
SEE TABLE BELOW

CAPACITY
**REFER TO OEM'S
RECOMMENDED LOAD
RATING**
COLOR

WHITE

CATALOG NUMBER

GMMBK4W

PRODUCT FEATURES

GM Express/Savana galvanized steel mounting bracket kit for PROFILE™ HD Utility, grip lock, drop down, and combo ladder racks. Mounting kit works for both 135" and 155" wheelbase vehicles.

SEE PAGE 2 FOR APPLICATION NOTES AND ACCESSORIES, OTHER PRODUCTS THAT WORK WITH THIS UNIT.



CATALOG NUMBER GMMBK4W

PRODUCT APPLICATION

This product is designed to be installed on GM Express/Savana vans. Works for HD Utility, grip lock, drop down, and combo ladder racks.

ACCESSORIES THAT WILL WORK WITH THIS PRODUCT

CATALOG NUMBER	DESCRIPTION	CATALOG NUMBER	DESCRIPTION
GMMBK2W	Mounting Bracket Kit, 2-Pack, White, Express, Savana	4UPK4B	4" Upright Kit, 4-Pack, Black
2BARW	2-Crossbar Kit, 68", White, Full Size Van	4UPK2B	4" Upright Kit, 2-Pack, Black
1BARW	Single Crossbar Kit, 68", White, Full Size Van	6UPK4B	6" Upright Kit, 4-Pack, Black
RRBGMW	Rear Roller Assist Bar, White, Express, Savana	6UPK2B	6" Upright Kit, 2-Pack, Black
70-1NGLR	4" End Cap for PVC Conduit	9UPK4B	9" Upright Kit, 4-Pack, Black
70-2NGLR	6" End Cap for PVC Conduit	9UPK2B	9" Upright Kit, 2-Pack, Black
80-1NGLR	Conduit Kit, 10w x 6h x 126d, Multiple Vehicles	RSK1B	Single Ratchet Upright Kit, 9"
80-2NGLR	Conduit Kit, 10w x 6h x 150d, Multiple Vehicles	ULSKB	Single Ladder Stop Kit

LADDER RACK HEIGHTS MEASURED FROM ROOF OF VEHICLE

CONFIGURATION	RACK HEIGHT
Base Rack	4"
Base + Ladder Stop	9.5"
Base + 4" Uprights	7.5"
Base + 6" Uprights	9.5"
Base + 9"/Ratchet Uprights	12.5"
Base + 4" PVC Conduit Kit	8.4"
Base + 6" PVC Conduit Kit	10.4"
Base + Aluminum Box Conduit Kit	10.5"

INSTR. NUMBER : 63458	PG: 1	REV: E	ITEM NO.	PART NUMBER	DESCRIPTION	GMMBK4W	GMMBK2W
PART NUMBER : GMMBK4 PART • UTILITY,MNT BKT KT,GM,2,W DESC. •			1	63856-W	UTILITY, GM MOUNT BRKT, WHITE	4	-
			2	22856-0	FOOT CLAMP - GMT600,WHITE	4	2
			3	63933	UTILITY, COM MOUNT PLATE	4	2
			4	63905-W	UTILITY,GM MID MNT BKT, WHITE	-	2

NOTE: THIS INSTRUCTION IS VALID FOR THE FOLLOWING KITS:

- GMMBK4W
- GMMBK2W
- GMMBK4B
- GMMBK2B

- PART NUMBERS WITH "-W" SUFFIX ARE PAINTED WHITE
 - FOR BLACK MOUNTING KITS, REPLACE "-W" PARTS WITH "-B" PARTS

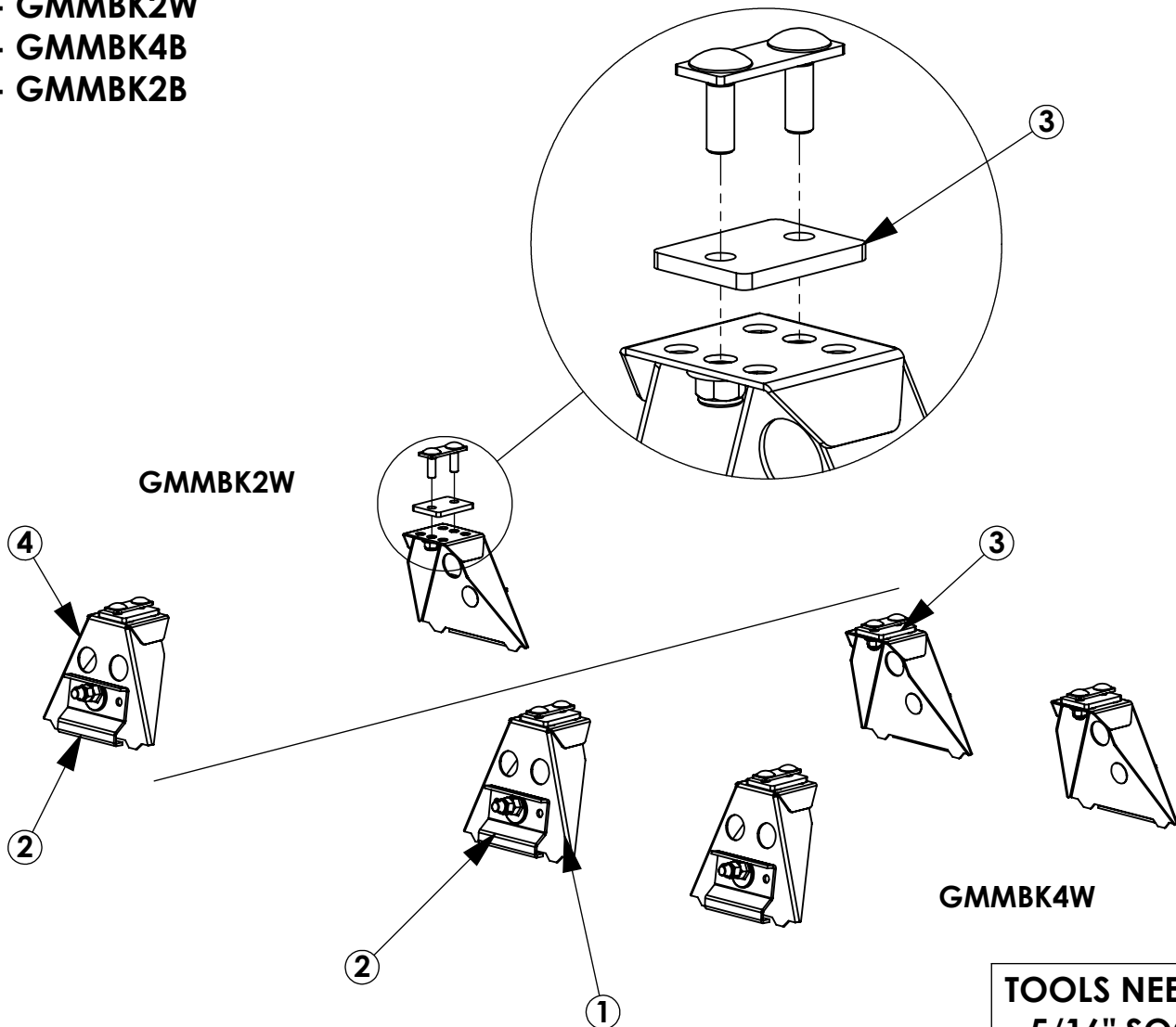

- TOOLS NEEDED:**
- 5/16" SOCKET
 - 9/16" SOCKET
 - 1/2" SOCKET
 - 5/8" WRENCH
 - DRIVE RATCHET
 - IMPACT DRIVER
 - TAPE MEASURE

GET TO KNOW THE VEHICLE - AT THE BEGINNING OF ANY INSTALLATION, CHECK THE LOCATION OF THE FUEL TANK, FUEL LINES, BRAKE LINES, HIGH VOLTAGE BATTERIES AND WIRING HARNESES TO AVOID INJURY OR PROPERTY DAMAGE FROM TOOL CONTACT.

SEAL ALL EXTERIOR HOLES - ALL INSTALLATION HOLES SHOULD BE SEALED WITH BUTYL TAPE OR SILICON TO PREVENT WATER AND EXHAUST GASES FROM ENTERING THE VEHICLE.

CONTROL DRILL DEPTH - TO AVOID DAMAGE TO THE VEHICLE, USE A DRILL STOP OR CLEARED STEP BIT WHEN DRILLING INSTALLATION HOLES.

ALWAYS ADD PRIMER - WHEN ADDING INSTALLATION HOLES BE SURE TO USE A SELF-ETCHING PRIMER TO PREVENT CORROSION, FASTENER FAILURE AND INJURY.

MOUNTING POINTS MUST HAVE METAL-TO-METAL CONTACT - USE PROVIDED MOUNTING SPACERS TO ACCOMMODATE FOR VEHICLE FEATURES, CARPET OR SUBFLOORS.

PROVIDE CLEARANCE FOR SPACERS - IF THE INSTALLATION VEHICLE CONTAINS A CARPET OR SUBFLOOR, USE A 1-3/16" DIAMETER CARPET CUTTER (P/N: 31183-0) AT ALL MOUNTING LOCATIONS TO OPEN UP ROOM FOR SPACERS.

CHECK SPACER ORIENTATION - BE SURE THAT THE INDENT IN THE SPACER COVERS THE PLUSNUT HEAD; THIS ENSURES THE MOST METAL-TO-METAL CONTACT AND REDUCES VIBRATION.

PLUSNUT INSTALLATION - A PLUSNUT GUN IS RECOMMENDED FOR PLUSNUT INSTALLATION FOR ITS PRODUCTION SPEED. HOWEVER, A PLUSNUT SETTING TOOL CAN ALSO BE USED (P/N: 22200-0).

THRU-BOLT CLEARANCE - WHEN USING A THRU-BOLT AT ANY MOUNTING LOCATION, BE SURE THAT YOUR HOLE HAS 1/16" CLEARANCE.

FASTENERS AND HARDWARE USED

BAG REFERENCE: BAG64733

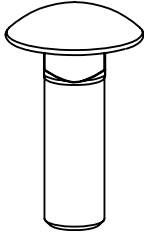

**FAS0398
5/16-18X1 SS
CRG BOLT
QTY: 8**

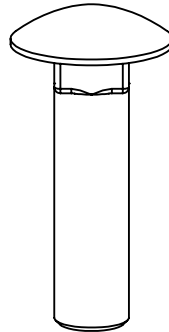

**FAS0117
3/8-16X1.5 ZN
CRG BOLT
QTY: 4**



**FAS0552
5/16 SS
FLAT WASHER
QTY: 8**

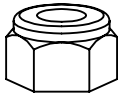

**FAS0248
5/16-18 SS
NLK HH NUT
QTY: 8**

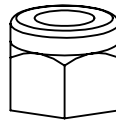

**FAS0110
3/8-16 SS
NLK HH NUT
QTY: 4**

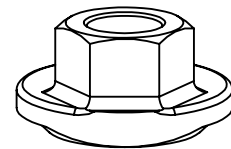

**07466-0
ADJUSTING
CAM NUT
QTY: 4**

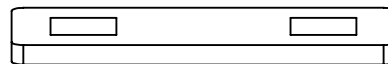

**63934
UTILITY,
BOLT PLATE
QTY: 4**

INTENTIONALLY LEFT BLANK



CHECK TABLES 1-4 IN INSTRUCTION 68895 FOR ADDITIONAL ACCESSORY SLIDE INSTALLATION BEFORE INSTALLING MOUNTING BRACKETS (ALL A.2 ITEMS SHOULD BE COMPLETELY INSTALLED FIRST!)

STEP 1 - ASSEMBLE MOUNTING BRACKETS TO CROSSBOW

STEP 1.1
LOOSELY
ASSEMBLE UNTIL
AFTER STEP 3
(2) FAS0398, (2)
FAS0552,
(2) FAS0248,
63934
(2 PLACES PER
CROSSBOW)
1/2" SOCKET

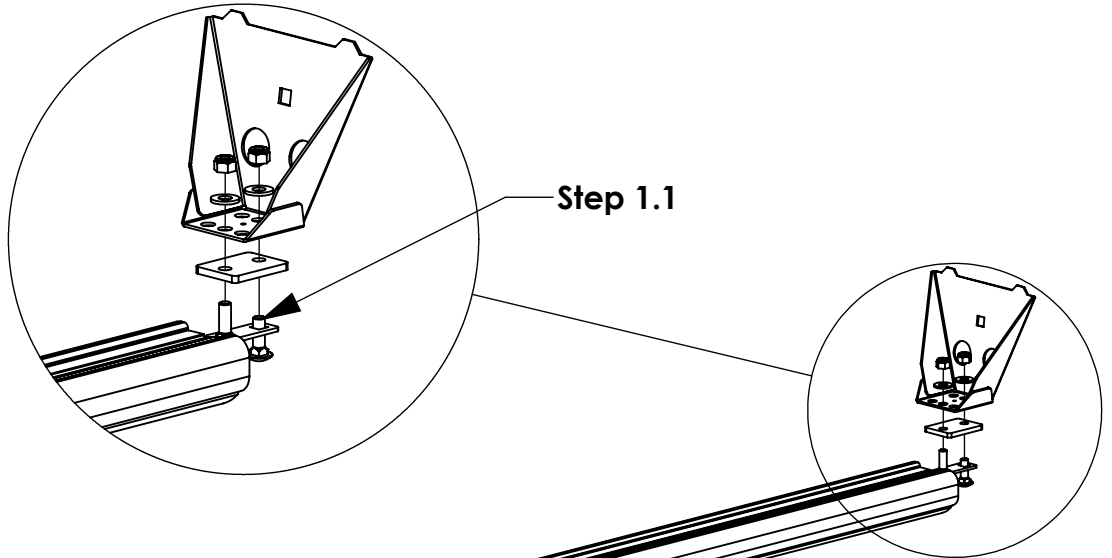

MOUNTING HOLES TO USE

HD UTILITY: CENTER MOUNTING HOLES

GRIP-LOCK: CENTER MOUNTING HOLES

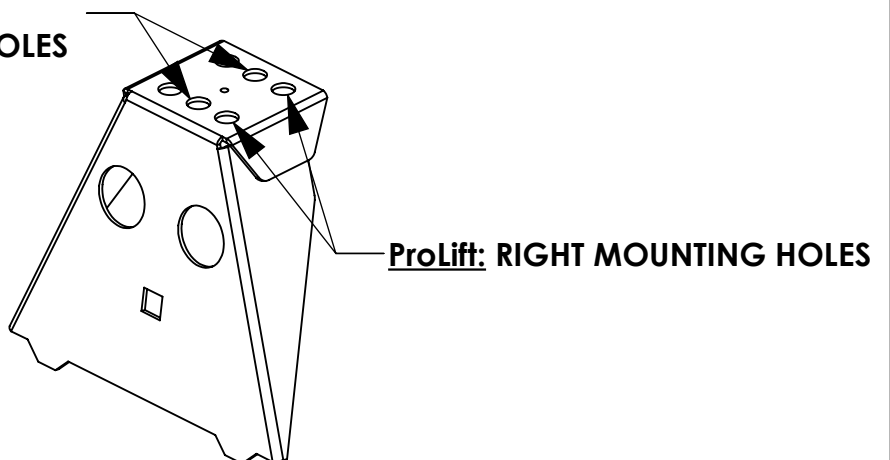

STEP 2 - INSTALL CROSSBOW ASSEMBLY ON VEHICLE ROOF

**STEP 2.1
FULLY TIGHTEN
FAS0110, 07466-
0, FAS0117
(2 PLACES PER
CROSSBOW)
9/16" SOCKET
5/8" WRENCH**

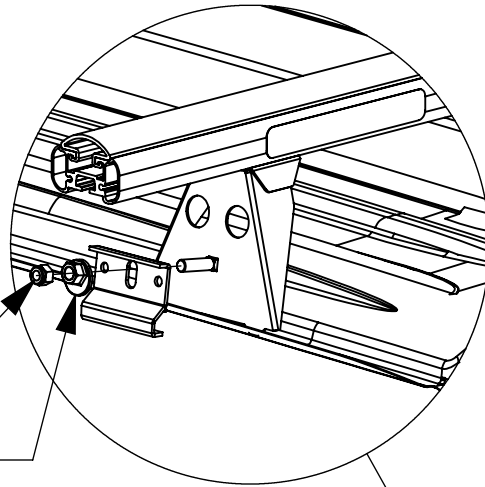

Step 2.1

**DO NOT
OVERTIGHTEN
ECCENTRIC
WASHER!**

**IF INSTALLING A THIRD CROSSBOW:
USE SHORTER MOUNTING BRACKET
(63905-W) FOR THE MIDDLE
CROSSBOW**

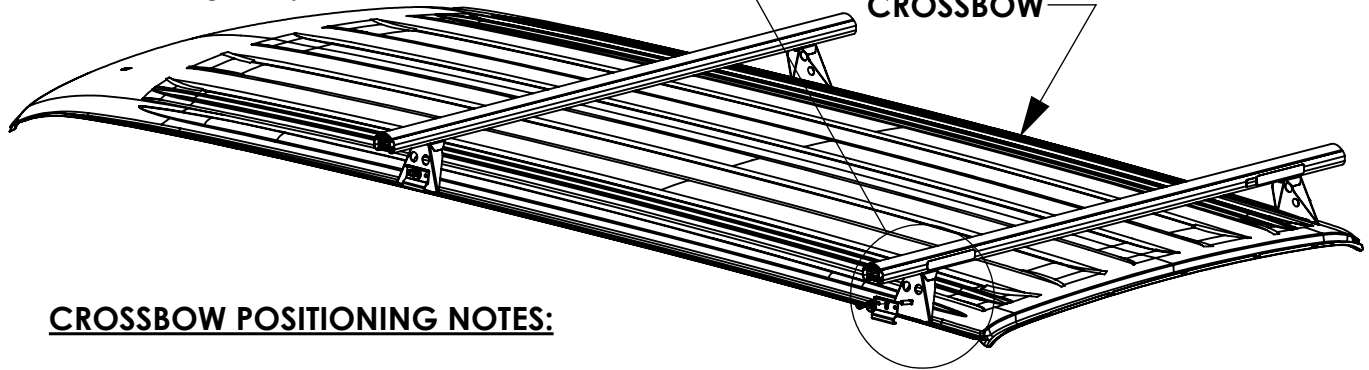

CROSSBOW POSITIONING NOTES:

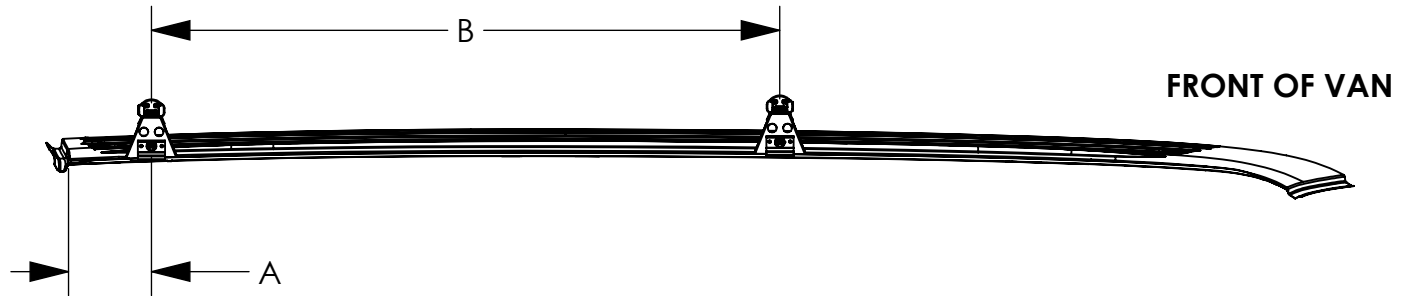

***** THESE DIMENSIONS ARE SUGGESTIONS, PLEASE
SPACE CROSSBOWS TO BEST FIT END USER'S PRODUCT**

DIMENSION	A - REAR CROSSBOW	B - FRONT CROSSBOW
HD UTILITY RACK	9 1/2"	72" ***
HD UTILITY RACK W/ REAR ROLLER	20 5/8"	72" ***
GRIP-LOCK	9 1/2"	76 3/8"
ProLift	9 1/2"	76 3/8"

STEP 3 - SECURE CROSSBOW

**STEP 3.1
CENTER CROSSBOW
AND
FULLY TIGHTEN
BRACKETS FROM STEP
1.1
(4 PLACES PER
CROSSBOW)
1/2" SOCKET**

HD UTILITY - 68 INCH CROSSBOW

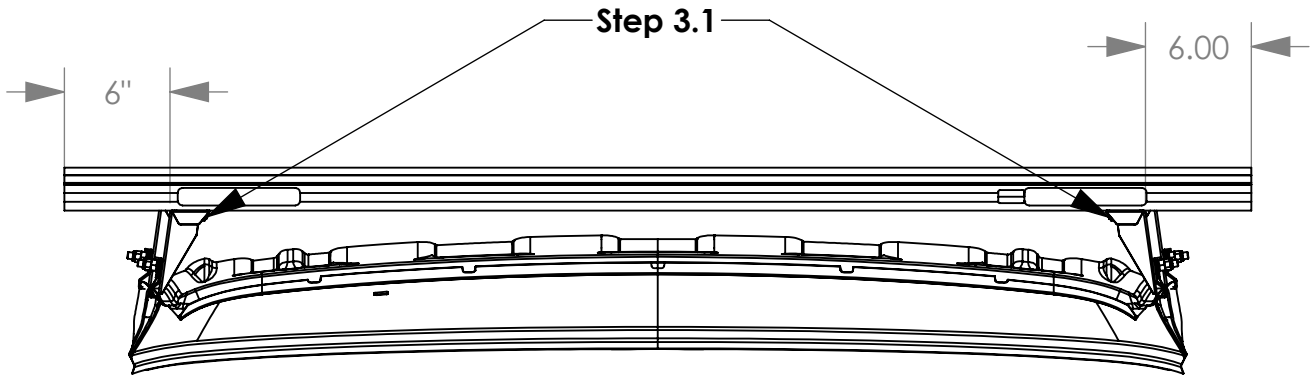

MEASURE TO OUTSIDE EDGE OF MOUNTING BRACKET.

DISTANCES MAY CHANGE DUE TO LOCATION ON RAIL.

Grip-Lock / ProLift - 58 INCH CROSSBOW

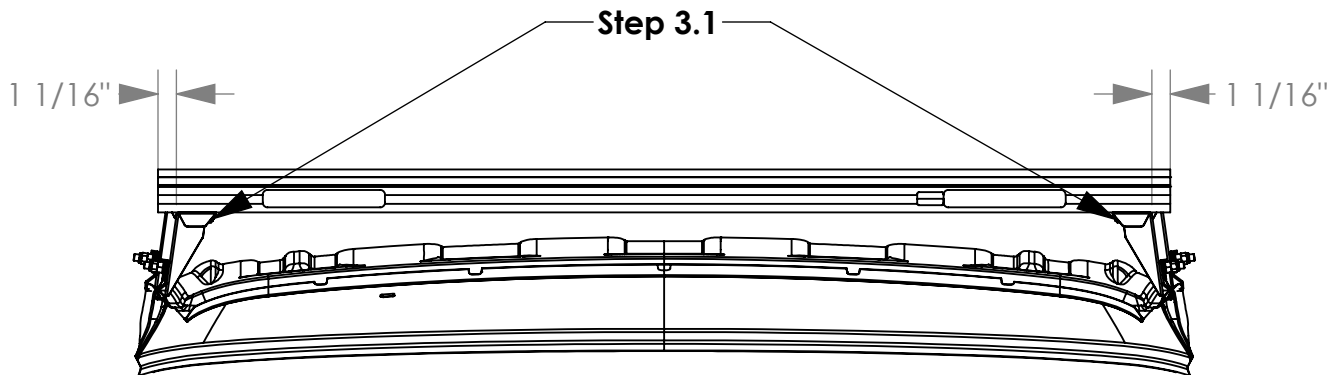



2-Crossbar Kit, 58", White, Minivan



PRODUCT WEIGHT
16.1 LBS

CROSSBOW LENGTH X
HEIGHT

59" x 2"

CAPACITY

**REFER TO OEM'S
RECOMMENDED LOAD
RATING**

COLOR

WHITE

CATALOG NUMBER

2BARCW

PRODUCT FEATURES

Aluminum base 2-crossbow kit for PROFILE™ HD Utility, grip lock, drop down, or combo ladder racks. Works with all compact van platforms for each respective wheelbase and Ford Transit Ship Thru. Works with and without OEM specific rail kit and generic mounting bracket kits.

Optional uprights and conduit kits available.

Please refer to OEM specific mounting kit or rail kit for additional information on compatible accessories.

INSTALLATION GUIDE FOR PROFILE™ SERIES LADDER RACKS

INSTRUCTION #:
68895

REV:
B

THIS INSTRUCTION PROVIDES A GENERAL GUIDE OF INSTALLATION SEQUENCE FOR ALL PROFILE™ SERIES LADDER RACKS. PLEASE ENSURE ALL ACCESSORIES ARE INSTALLED PER TYPE OF RACK BEFORE PROCEEDING TO NEXT PAGE.

REFERENCE THIS INSTRUCTION THROUGHOUT THE ENTIRETY OF YOUR INSTALL TO PREVENT ACCESSORIES BEING INSTALLED INCORRECTLY/OUT OF SEQUENCE!

STEPS 21 - 81 ON PAGE 3 IS THE RECOMMENDED ASSEMBLY SEQUENCE FOR A FULL TABLE ASSEMBLY BEFORE INSTALLING ON THE ROOF OF THE VEHICLE.

STEPS 2R - 8R ON PAGE 4 IS AN ALTERNATE ASSEMBLY SEQUENCE TO INSTALL THE RACK ON THE VEHICLE ROOF AS IT IS BUILT.

PLEASE SELECT THE ASSEMBLY SEQUENCE THAT BEST WORKS FOR YOU!

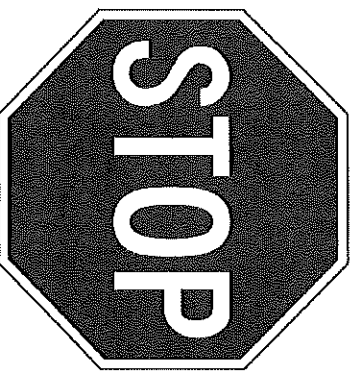

ASSEMBLY STEPS:

STEP 1A. SUB-ASSEMBLE EACH CROSSBOW WITH DESIRED ACCESSORIES FOR SECTIONS A.1 & A.2.

INSTRUCTIONS FOR EACH KIT CAN BE FOUND IN THEIR RESPECTIVE CARTON!

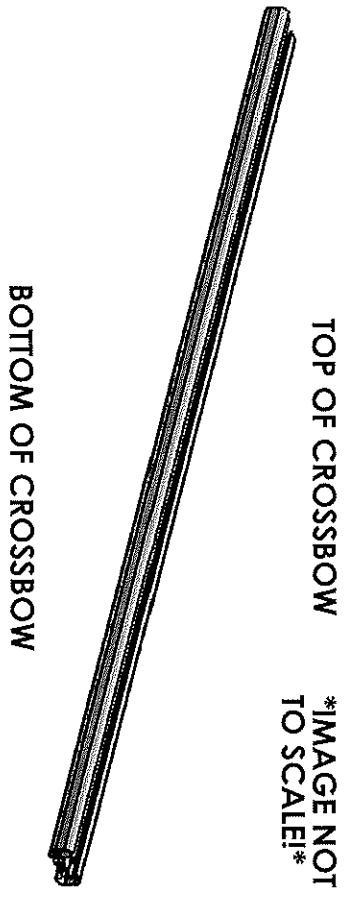

TABLE 1

TOP OF CROSSBOW		COMPONENTS TO INSTALL
A.1		HD UTILITY - CONDUIT KIT OR BEACON
		Grip-Lock - CONDUIT KIT OR BEACON
		ProLift - CONDUIT KIT OR BEACON
BOTTOM OF CROSSBOW		COMPONENTS TO INSTALL
A.2		HD UTILITY - LADDER STOP, STROBE BRACKET, AND/OR REAR ROLLER
		Grip-Lock - Grip-Lock SUB-ASSEMBLY
		ProLift - DAMPER BRACKET

STEP 1B. SUB-ASSEMBLE EACH CROSSBOW WITH DESIRED ACCESSORIES FOR SECTIONS B.1 & B.2. INSTRUCTIONS FOR EACH KIT CAN BE FOUND IN THEIR RESPECTIVE CARTON!

TOP OF CROSSBOW

IMAGE NOT TO SCALE!

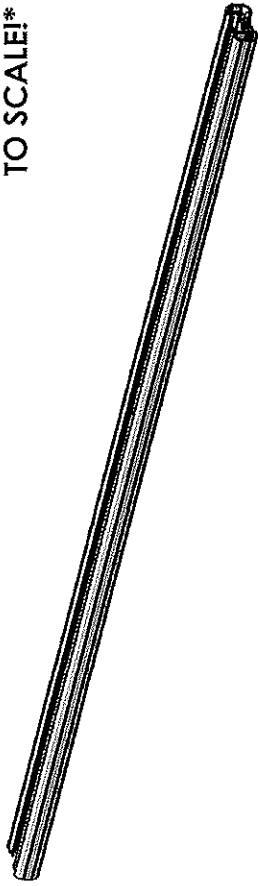

BOTTOM OF CROSSBOW

TABLE 2

TOP OF CROSSBOW	
	COMPONENTS TO INSTALL
HD UTILITY	- WEAR STRIP (MODIFY IF NECESSARY, TABLE 3)
Grip-Lock	- WEAR STRIP (MODIFY IF NECESSARY, TABLE 3)
ProLift	- INNER STOP POST
BOTTOM OF CROSSBOW	
	COMPONENTS TO INSTALL
HD UTILITY	- MOUNTING BRACKETS
Grip-Lock	- MOUNTING BRACKETS
ProLift	- MOUNTING BRACKETS

ALTER WEAR STRIP AND INSTALL ON CROSSBOW (IF APPLICABLE)! REFERENCE TABLE 3 BELOW FOR WEAR STRIP ALTERATION INSTRUCTIONS!

TABLE 3

ADDED ACCESSORIES	ALTERATION FOR WEAR STRIP
4" UPRIGHT***	REMOVE 2" FROM END OF WEAR STRIP
4" PVC CONDUIT KIT	REMOVE 7.25" FROM CENTER OF WEAR STRIP
6" PVC CONDUIT KIT	REMOVE 9.50" FROM CENTER OF WEAR STRIP
ALUMINUM BOX CONDUIT KIT	REMOVE 13.25" FROM CENTER OF WEAR STRIP
BEACON	REMOVE 4" FROM CENTER OF WEAR STRIP
ProLift (SINGLE SIDE)	CUT WEAR STRIP IN HALF, DO NOT INSTALL ON ProLift SIDE
ProLift (DUAL SIDE)	DO NOT INSTALL WEAR STRIP

SLIDE WEAR STRIP INTO RAIL AND CENTER (1 PER CROSSBOW)

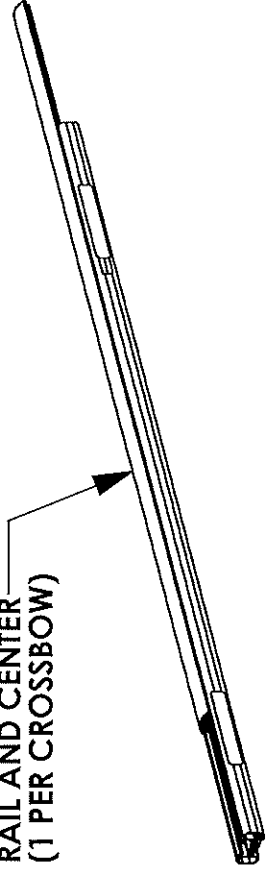

STEP 1C SUB-ASSEMBLE EACH CROSSBOW WITH DESIRED ACCESSORIES FOR SECTIONS C.1 & C.2

TOP OF CROSSBOW
IMAGE NOT TO SCALE!

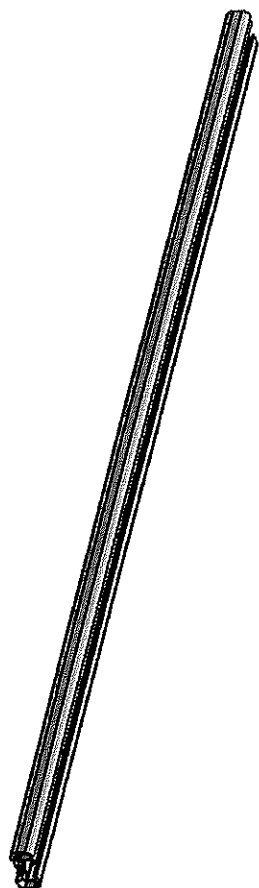

BOTTOM OF CROSSBOW

TABLE 4

TOP OF CROSSBOW		BOTTOM OF CROSSBOW	
COMPONENTS TO INSTALL		COMPONENTS TO INSTALL	
	HD UTILITY	- 4" UPRIGHT	
C.1	Grip-Lock	- N/A	
	Prolift	- SLIDES FOR BASE EXTRUSION	
BOTTOM OF CROSSBOW			
COMPONENTS TO INSTALL			
	HD UTILITY	- UPRIGHTS (6", 9", RATCHET)	
C.2	Grip-Lock	- STROBES	
	Prolift	- STROBES	

ASSEMBLY STEPS (FULL BENCH ASSEMBLY):

- 2T. ADD DRIVELINES (IF INSTALLING Prolift)
- 3T. ADD HANDLES (IF INSTALLING Grip-Lock OR Prolift) AND DAMPERS (IF INSTALLING Prolift)
- 4T. ADD OUTER SUPPORT BARS (IF INSTALLING Grip-Lock OR Prolift)
- 5T. ADD STEP LADDER KIT (Grip-Lock OR Prolift ONLY)

6T. ASSEMBLE ENDS CAPS TO CROSSBOW

USED FOR HD UTILITY & Grip-Lock RACKS

LOCATED IN CROSSBOW KIT

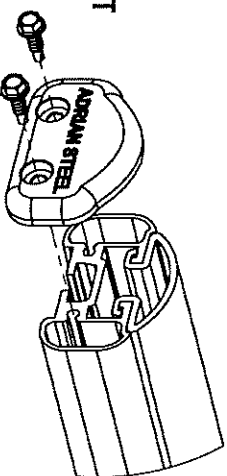

FULLY TIGHTEN
(2) FAS0473, 63851
(2 PLACES PER END CAP)
5/16" SOCKET

USED FOR Prolift RACKS
LOCATED IN Prolift Kit

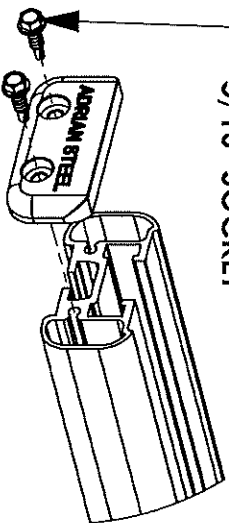

7T. INSTALL ROOF RAIL KIT ON VEHICLE ROOF OR BOTTOM MOUNTING BRACKETS

(ROOF RAIL KIT REQUIRED FOR Grip-Lock & Prolift OPTIONAL FOR HD UTILITY, NOT NEEDED FOR GM LADDER RACKS)

8T. MOUNT CROSSBOW SUB-ASSEMBLIES FROM STEP 1 TO VEHICLE/MOUNTING BRACKET, OR ROOF RAIL (LOOSE INSTALL)

ALTERNATE ASSEMBLY METHOD!
(ASSEMBLE ON VEHICLE ROOF):

- 2R. INSTALL ROOF RAIL KIT ON VEHICLE ROOF OR BOTTOM MOUNTING BRACKETS
(ROOF RAIL KIT REQUIRED FOR Grip-Lock & ProLift, OPTIONAL FOR HD UTILITY, NOT NEEDED FOR GM LADDER RACKS)
- 3R. MOUNT CROSSBOW SUB-ASSEMBLIES FROM STEP 1 TO VEHICLE/MOUNTING BRACKET, OR ROOF RAIL (LOOSE INSTALL)
- 4R. ADD DRIVELINES (IF INSTALLING ProLift)
- 5R. ADD HANDLES (IF INSTALLING Grip-Lock OR ProLift) AND DAMPERS (IF INSTALLING ProLift)
- 6R. ADD OUTER SUPPORT BARS (IF INSTALLING Grip-Lock OR ProLift)
- 7R. ADD STEP LADDER KIT (Grip-Lock OR ProLift ONLY!)

8R. ASSEMBLE END CAPS TO CROSSBOW

USED FOR HD UTILITY & Grip-Lock RACKS

LOCATED IN CROSSBOW KIT

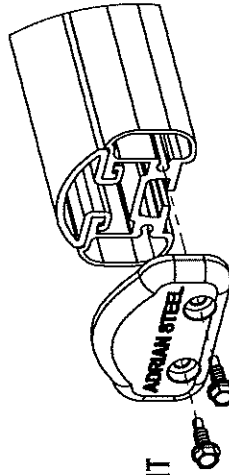

FULLY TIGHTEN
(2) FAS0473, 63851
(2 PLACES PER END CAP)
5/16" SOCKET

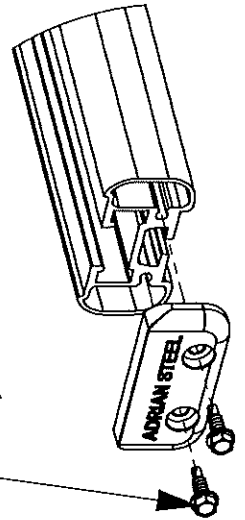

USED FOR ProLift RACKS
LOCATED IN ProLift Kit