

INSTR. NUMBER : 63419	PG: 1	REV: D	ITEM NO.	PART NUMBER	DESCRIPTION	FTMBK4W	FTMBK2W
PART NUMBER : FTMBK			1	68202-W	PROFILE, MOUNTING ARM, W	4	2
			2	63852-W	UTILITY, MOUNTING BRKT, W	4	2
PART DESC. : UTILITY, MNT BKT KT, FT			3	47106	GASKET, FOOT, MR TRANS L/R	4	2
			4	64777	UTILITY, FRONT SPACER, FT	-	2

NOTE: THIS INSTRUCTION IS VALID FOR THE FOLLOWING KITS:

- FTMBK4W
- FTMBK2W
- FTMBK4B
- FTMBK2B

- PART NUMBERS WITH "-W" SUFFIX ARE PAINTED WHITE
 - FOR BLACK MOUNTING KITS, REPLACE "-W" PARTS WITH "-B" PARTS

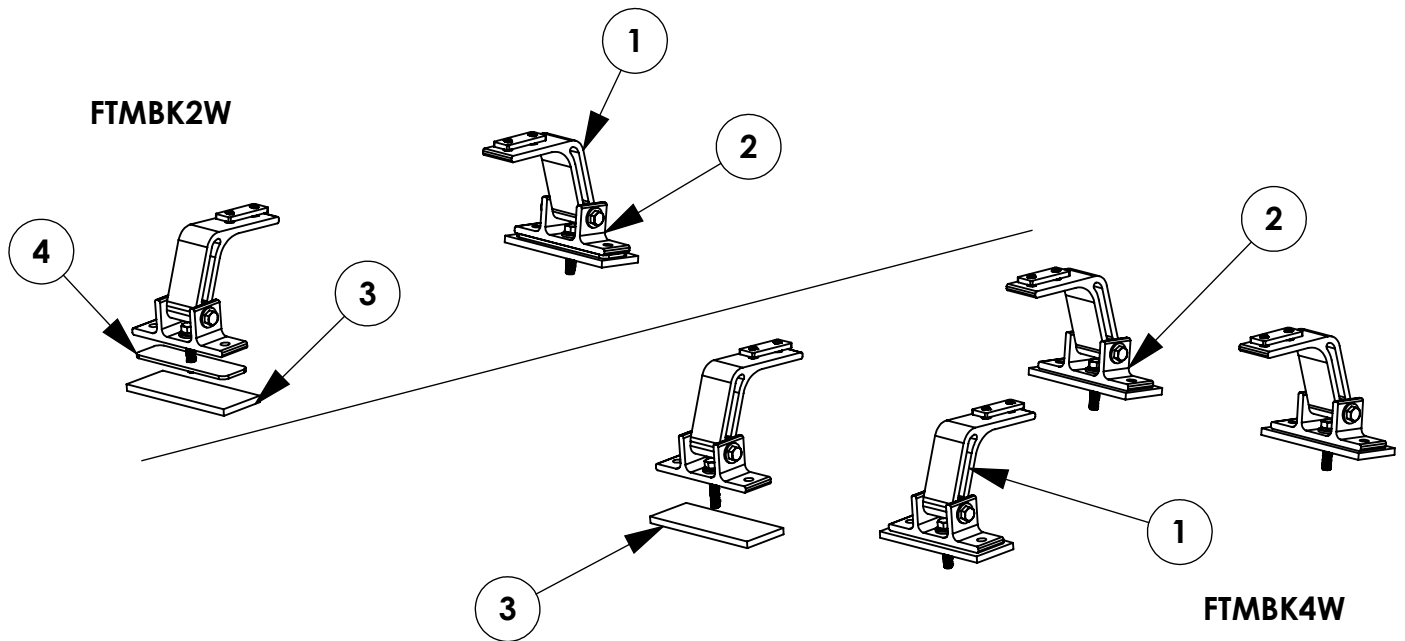

GET TO KNOW THE VEHICLE - AT THE BEGINNING OF ANY INSTALLATION, CHECK THE LOCATION OF THE FUEL TANK, FUEL LINES, BRAKE LINES, HIGH VOLTAGE BATTERIES AND WIRING HARNESSSES TO AVOID INJURY OR PROPERTY DAMAGE FROM TOOL CONTACT.

SEAL ALL EXTERIOR HOLES - ALL INSTALLATION HOLES SHOULD BE SEALED WITH BUTYL TAPE OR SILICON TO PREVENT WATER AND EXHAUST GASES FROM ENTERING THE VEHICLE.

CONTROL DRILL DEPTH - TO AVOID DAMAGE TO THE VEHICLE, USE A DRILL STOP OR CLEARED STEP BIT WHEN DRILLING INSTALLATION HOLES.

ALWAYS ADD PRIMER - WHEN ADDING INSTALLATION HOLES BE SURE TO USE A SELF-ETCHING PRIMER TO PREVENT CORROSION, FASTENER FAILURE AND INJURY.

MOUNTING POINTS MUST HAVE METAL-TO-METAL CONTACT - USE PROVIDED MOUNTING SPACERS TO ACCOMMODATE FOR VEHICLE FEATURES, CARPET OR SUBFLOORS.

PROVIDE CLEARANCE FOR SPACERS - IF THE INSTALLATION VEHICLE CONTAINS A CARPET OR SUBFLOOR, USE A 1-3/16" DIAMETER CARPET CUTTER (P/N: 31183-0) AT ALL MOUNTING LOCATIONS TO OPEN UP ROOM FOR SPACERS.

CHECK SPACER ORIENTATION - BE SURE THAT THE INDENT IN THE SPACER COVERS THE PLUSNUT HEAD; THIS ENSURES THE MOST METAL-TO-METAL CONTACT AND REDUCES VIBRATION.

PLUSNUT INSTALLATION - A PLUSNUT GUN IS RECOMMENDED FOR PLUSNUT INSTALLATION FOR ITS PRODUCTION SPEED. HOWEVER, A PLUSNUT SETTING TOOL CAN ALSO BE USED (P/N: 22200-0).

THRU-BOLT CLEARANCE - WHEN USING A THRU-BOLT AT ANY MOUNTING LOCATION, BE SURE THAT YOUR HOLE HAS 1/16" CLEARANCE.

FASTENERS USED

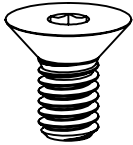

FAS0858
5/16-18X.63 SS
FHH SCREW
QTY: 8

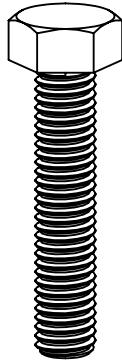

FAS0351
M8-1.25X40 SS
HH SCREW
QTY: 4



FAS0243
5/16-18X2.5 SS
HH SCREW
QTY: 4

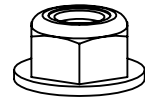

FAS0861
5/16-18 SS
HH FLG NUT
QTY: 4



FAS0857
5/16 SS WASHER,
LCK EXT CS
QTY: 8



FAS0588
5/16 SS
SPLIT WASHER
QTY: 4



FAS0552
5/16 SS
FLAT WASHER
QTY: 8

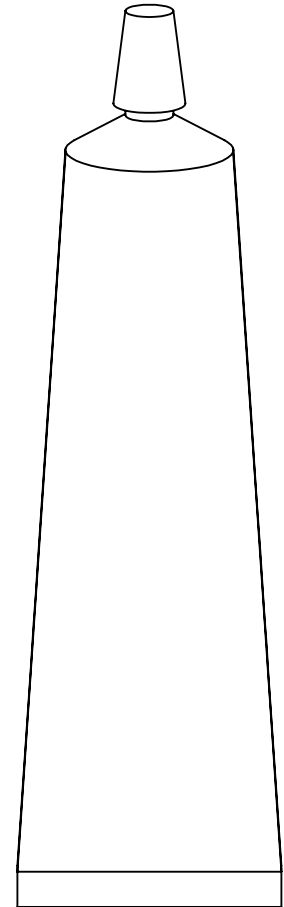

26618-0
SILICONE
1 OZ TUBE
QTY: 1



68042
PROFILE FOOT
MOUNTING PLATE
QTY: 4

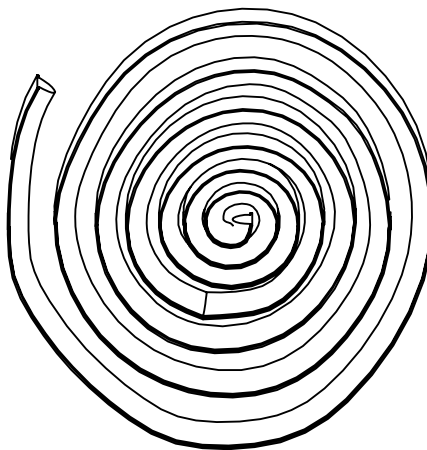

05586-0
BUTYL TAPE
T224 1FT ROLL
QTY: 1

STEP 1 - ASSEMBLE MOUNTING ARMS TO CROSSBOW

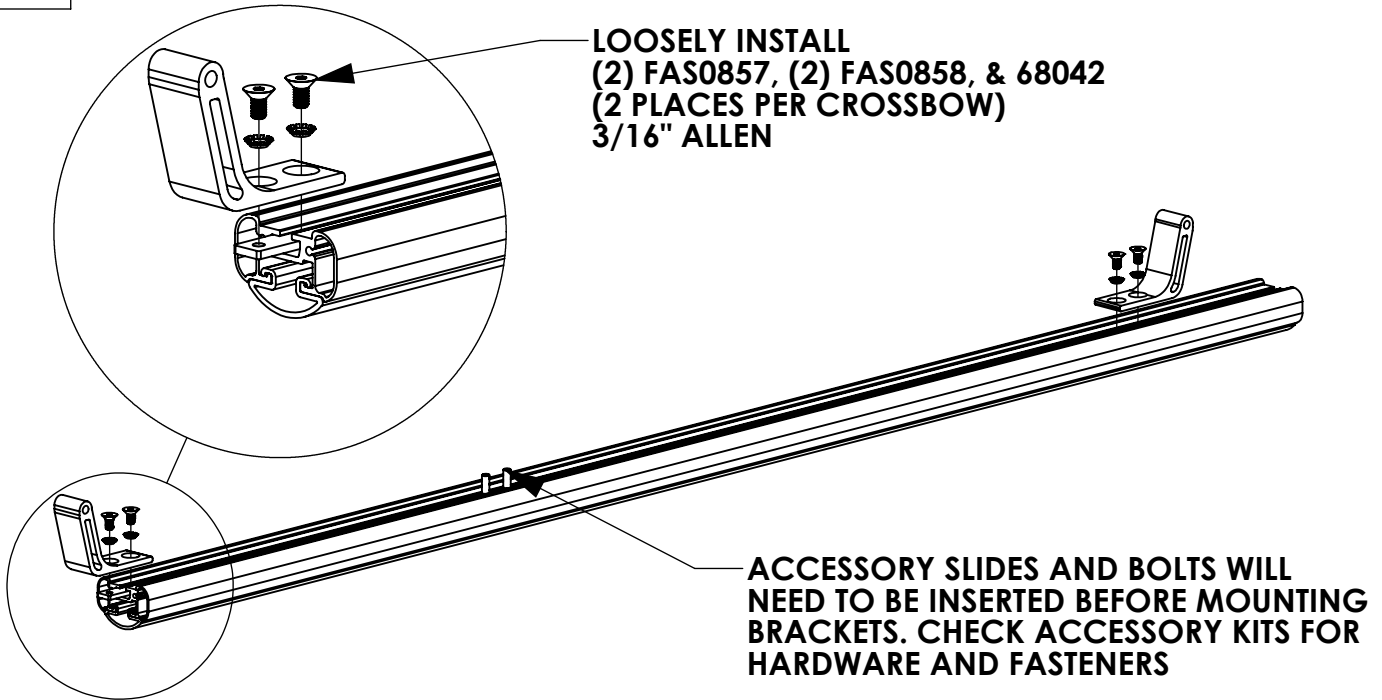

STEP 2 - INSTALL MOUNTING BRACKETS TO VEHICLE ROOF

CROSSBOW POSITIONING NOTES:

- REAR CROSSBOW - REAR OEM MOUNTING LOCATION
- FRONT CROSSBOW - POSITION TO BEST FIT END USER'S PRODUCT

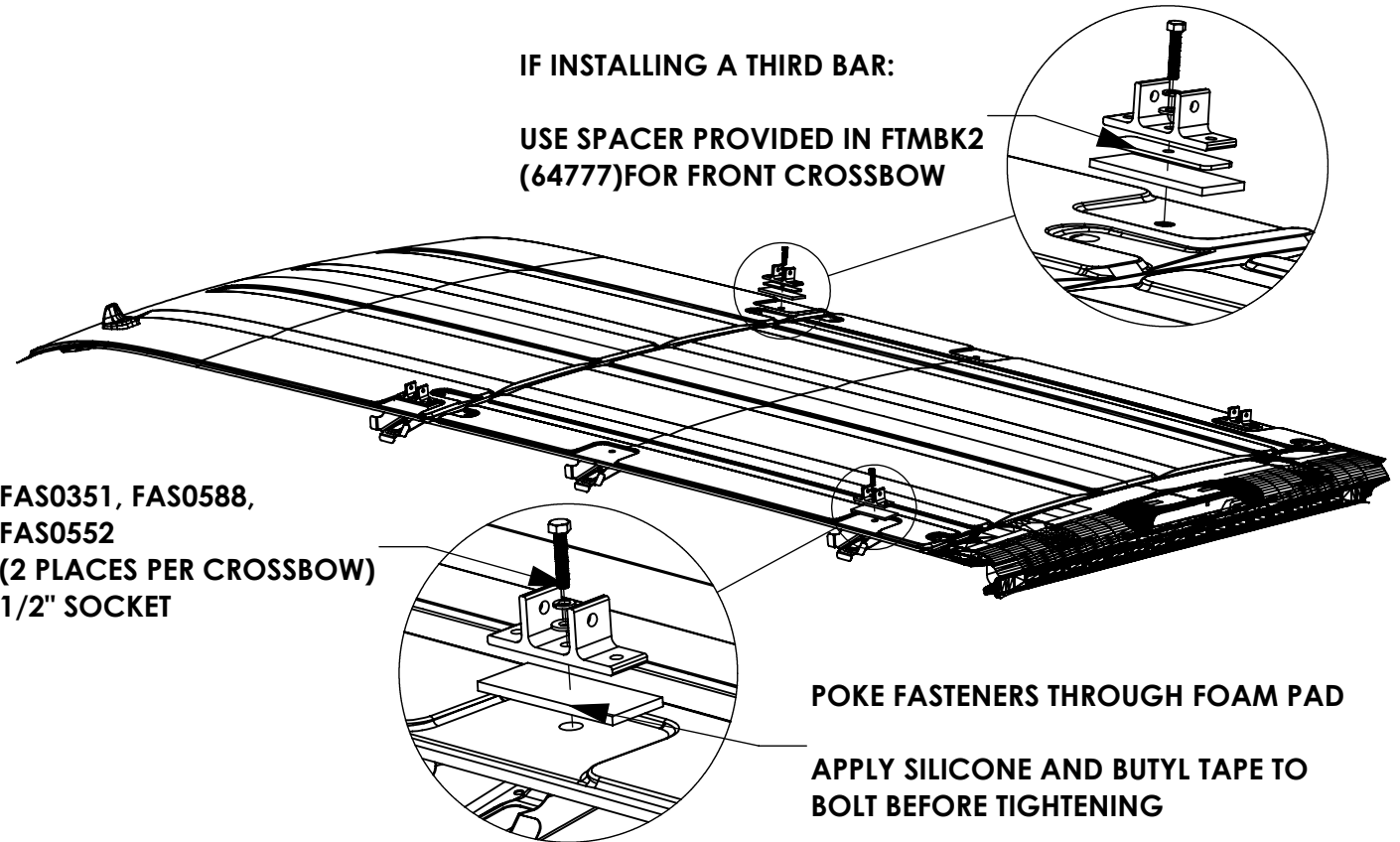

STEP 3 - ATTACH CROSSBOW ASSEMBLY TO MOUNTING BRACKETS

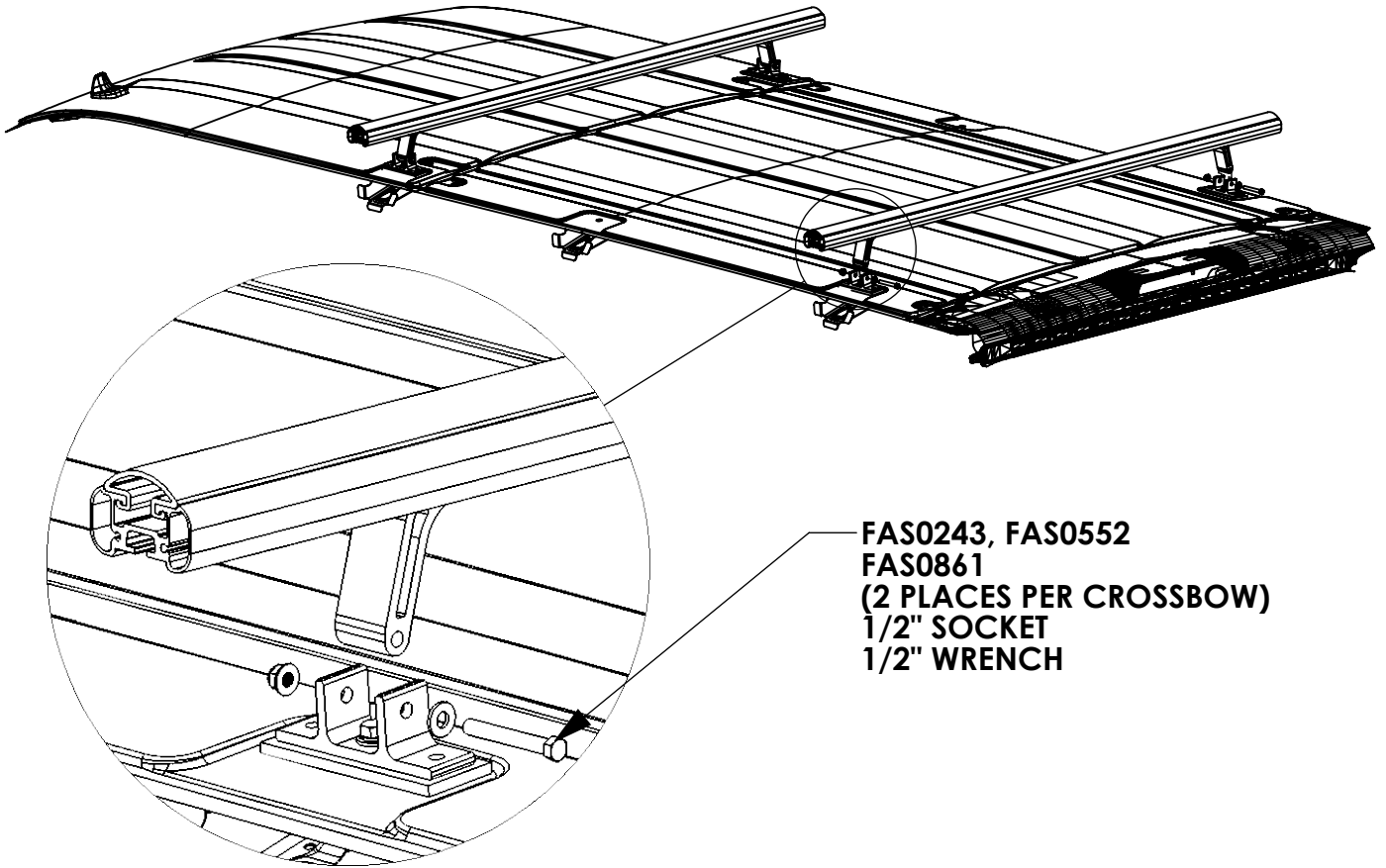

STEP 4 - SECURE CROSSBOW

CENTER CROSSBOW AND
SECURE MOUNTING BRACKETS
(4 PLACES PER CROSSBOW)
3/16" ALLEN

