

PRODUCT WEIGHT
109 lbs

WIDTH x DEPTH x HEIGHT
91" X 113" X 18"

CAPACITY
28 FOOT EXT

COLOR
Aluminum / Black

CATALOG NUMBER
DDL64FTL2

PRODUCT FEATURES

This drop down, grip lock combo rack along with the roof cross-bow kit is designed to fit the Ford Transit, 130 and 148 wheel base. The drop down will carry 20 to 28 foot extension ladders, and 10-12 foot step ladders. Step ladders shorter than 10' require DDLRSLK2 step ladder kit. Step ladders wider than 26" at the base require the wide step ladder add on, part 57107. Ladders with extensive gussets or platform step ladders may not be compatible with the rack.

The cross-bow kit is secured to the Ford Transit by OEM supplied fastening points.

SEE PAGE 2 FOR APPLICATION NOTES AND ACCESSORIES, OTHER PRODUCTS THAT WORK WITH THIS UNIT.

CATALOG NUMBER **DDL64FTL2****PRODUCT APPLICATION**

This Drop down grip lock combo is designed to fit 2016 and newer Ford Transit, low roof vehicles.

ACCESSORIES THAT WILL WORK WITH THIS PRODUCT**CATALOG NUMBER****DESCRIPTION****DDL64FTL2** **STEP LADDER KIT****GLSLKFSV** **GRIP LOCK STEP LADDER KIT****69-DDCS** **DDL64FTL2 EXTENSION, CURB SIDE-32 FOOT EXTENSION LADDER****69-GL** **GRIP LOCK LADDER RACK EXTENSION-32 FOOT EXTENSION LADDER****80-1LR**
80-2LR **CONDUIT KITS, ALUMINUM****70-1LR**
70-2LR **CONDUIT KITS, PVC****57107** **DDL64FTL2 WIDE STEP LADDER KIT-ADD ON PIECE****SPECIAL APPLICATION NOTES**

Introduction / Comments:

THIS DROP DOWN UNIT IS CURB SIDE, STREET SIDE SPECIFIC. THE DROP DOWN IS FOR LOW ROOF VEHICLES, THESE INSTRUCTIONS WILL BE SHOWING THE GM FSV AND SOME FORD TRANSIT PICTURES FOR THE VEHICLE REPRESENTATION. THIS DROP DOWN LADDER RACK IS DESIGNED TO ADAPT TO AN ADRIAN STEEL CROSS BOW KIT FOR VARIOUS STANDARD ROOF VEHICLES.

Note:

It is advised that all fasteners used in this assembly and installation of this Rack should be checked for tightness at the following intervals: @ 2-weeks and again @ 6-weeks of operation. This preventive maintenance step must be completed to ensure your package gives you long service life.

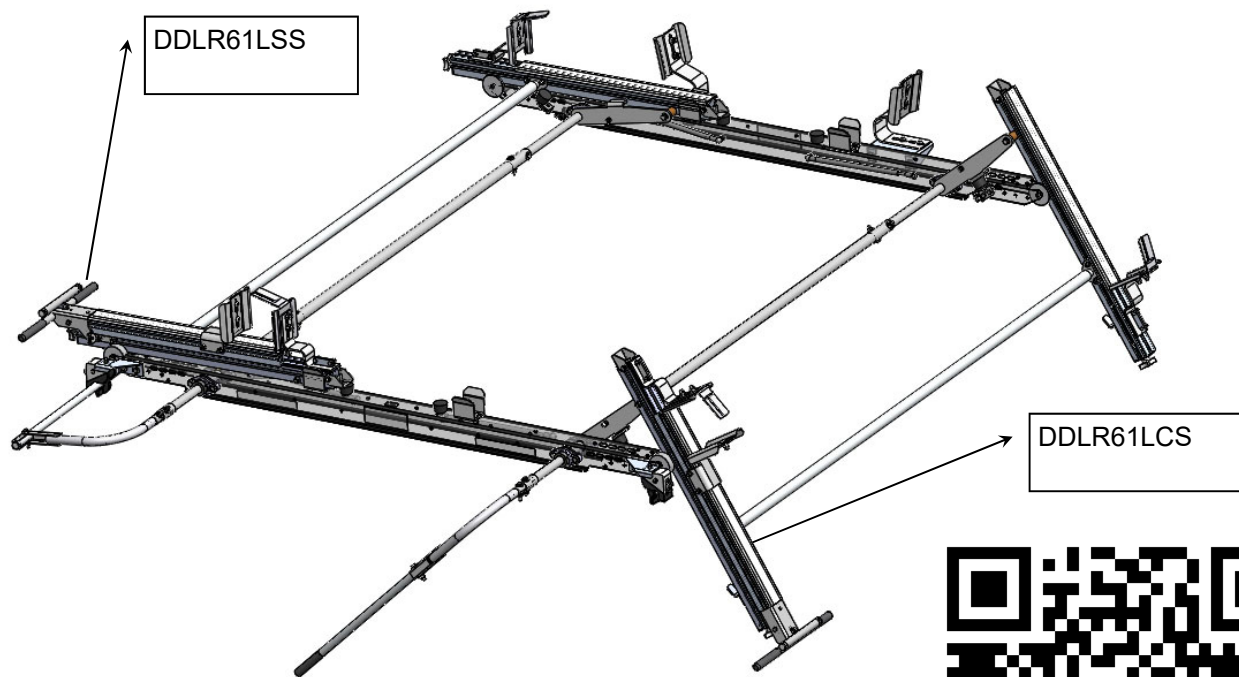

TO VIEW INSTALL VIDEO

**DDL61GM / DDL63GM
FINAL DROP DOWN LADDER RACK, STREET, CURB
GM FSV, LOW ROOF VAN**

- PRECAUTIONS -





 **CAUTION** 
**THE USE OF AIR IMPACT TOOLS CAN
OVER-TORQUE FASTENERS AND
CAUSE FASTENER FAILURE!**



 **CAUTION** 
**ALL INSTALLATION HOLES SHOULD BE SEALED
WITH SILICON OR BUTYL SEALANT TO PREVENT
EXHAUST FUMES FROM ENTERING THE VEHICLE!**



 **DANGER** 
**INSPECT FOR FUEL TANK, FUEL LINES, BRAKE LINES, HIGH
VOLTAGE BATTERIES AND ELECTRICAL LINES PRIOR TO
DRILLING TO AVOID DAMAGING CRITICAL VEHICLE SYSTEMS
OR INJURY TO INSTALLER DURING INSTALLATION PROCESS!**



 **CAUTION** 
**TO AVOID DAMAGING THE VEHICLE ALWAYS
USE DRILL STOPS WHEN DRILLING ANY IN-
STALLATION HOLES!**



- IMPORTANT WARRANTY REQUIREMENTS -

1. SUBSTITUTING ADRIAN STEEL SPECIFIED FASTENERS FOR ASSEMBLY AND/OR INSTALLATION WILL VOID YOUR PRODUCT WARRANTY.
2. ALL HOLES DRILLED INTO VEHICLE SHOULD HAVE THE RAW METAL EDGES SEALED WITH A SELF-ETCHING PRIMER TO RESIST CORROSION AND POTENTIAL FASTENER POINT FAILURE.
3. ALL FASTENERS USED IN THE INSTALLATION OF THIS PRODUCT SHOULD BE TIGHTENED TO THE TORQUE(S) SPECIFIED IN THESE INSTRUCTIONS.
4. THESE INSTRUCTIONS SHOULD BE KEPT WITH THE VEHICLE.

THE BASIC TOOLS NEEDED FOR MOST INSTALLATIONS



DRILL



DRILL BIT WITH
STOP

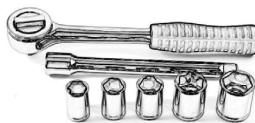

RATCHET, SOCKETS
AND/OR WRENCHES



SCREWDRIVERS



MEASURING TAPE

ADDITIONAL TOOLS MAY BE NEEDED FOR THIS INSTALLATION AND THEY WILL BE IDENTIFIED IN THE STEPS THAT FOLLOW.

BAG51041—FINAL ASSEMBLY FASTENER BAG

ITEM NO.	PART NUMBER	DESCRIPTION	QTY.
1	BAG0507-A	5" x 7" 3MIL AUTOBAG	1
2	FAS0246	Washer, Flat, 3/8, HRD, ZN	6
3	FAS0799	Screw, Hex Hd, 5/16-18x0.75 SS	4
4	FAS0110	Nut,Hex Nylk 3/8-16 SS W	4
5	FAS0572	Screw, Button Hd Hex Soc, 3/8-16x1.00 NI-ZN	2
6	FAS0588	Washer, Lock, Split, 5/16, SS	4
7	FAS0286	SCREW, HHCS, 3/8-16x4, SS	2
8	FAS0287	COTTER PIN, 1/16DIA X 1"LG, SS	2

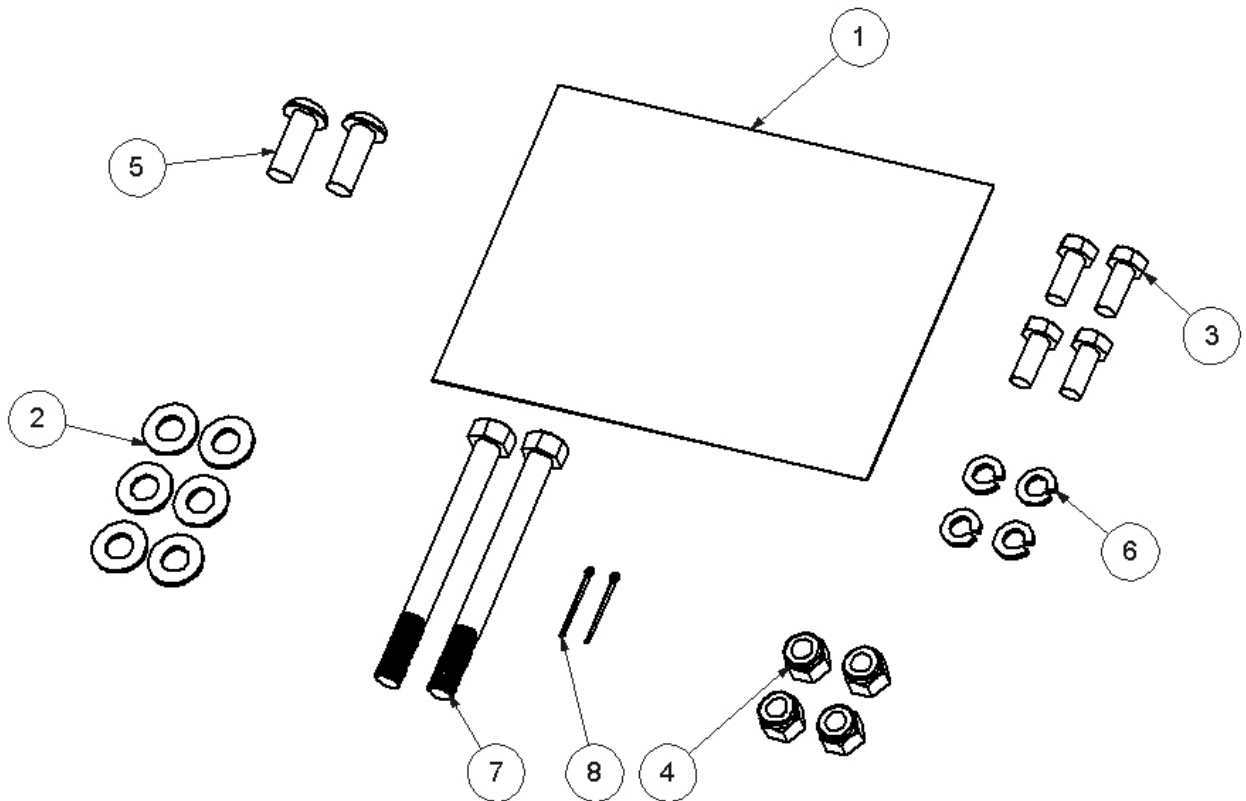



STEP 1A : THIS IS THE SHIP THRU SINGLE DROP DOWN AS YOU WOULD RECEIVE FOR FINAL DEALER ASSEMBLY. SEE STEP 1B FOR DOUBLE DROP DOWN.

SHOWING A GM FSV
RRKGMFSV
CROSS BOW KIT
ORDERED
SEPERATELY





STEP 1B : THIS IS THE SHIP THRU DOUBLE DROP DOWN AS YOU WOULD RECEIVE FOR FINAL DEALER ASSEMBLY

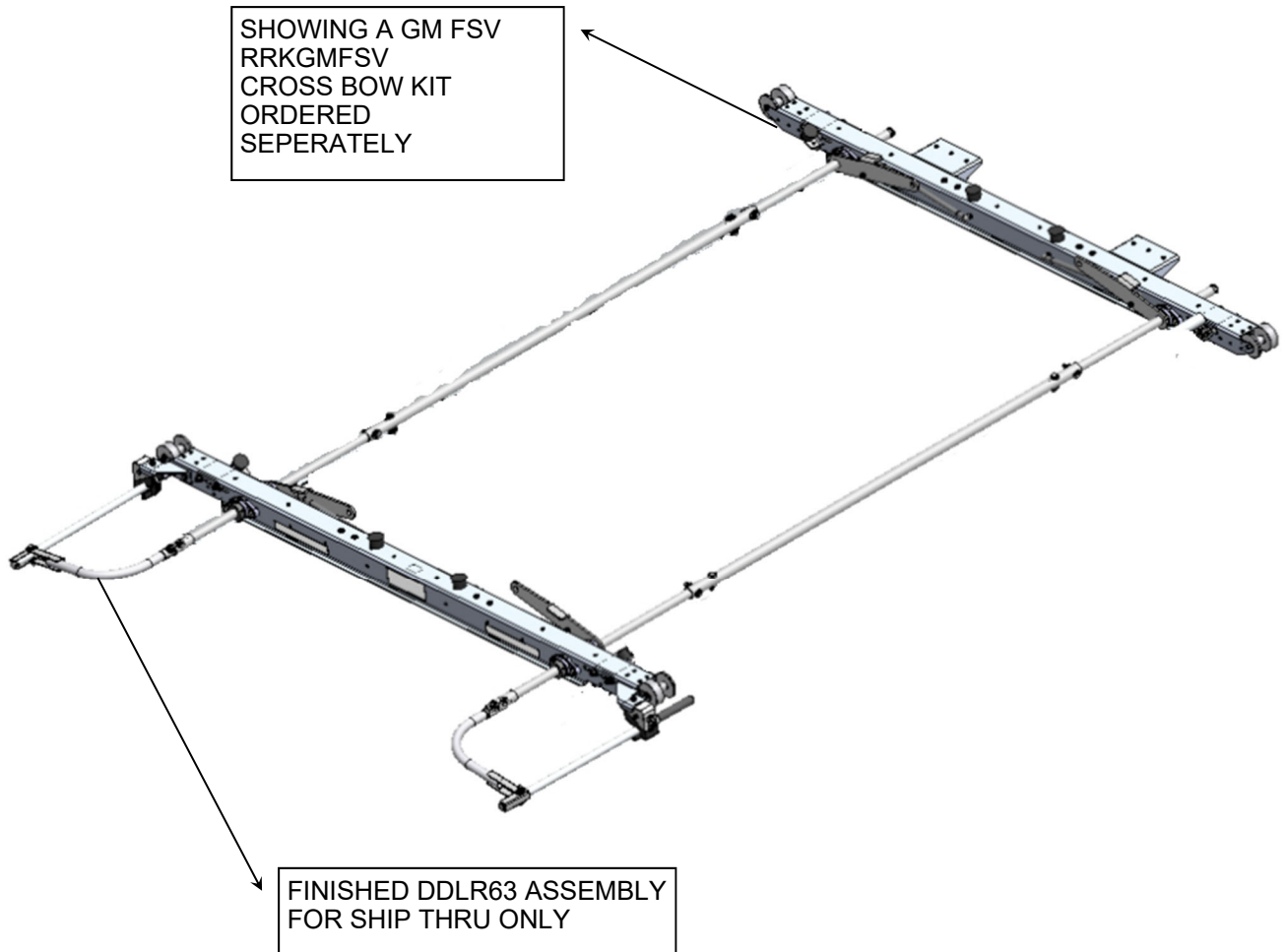



STEP 2 - THIS IS THE FINAL ASSEMBLY, SHOWING THE CURB AND STREET SIDE DROP DOWN COMPONENTS

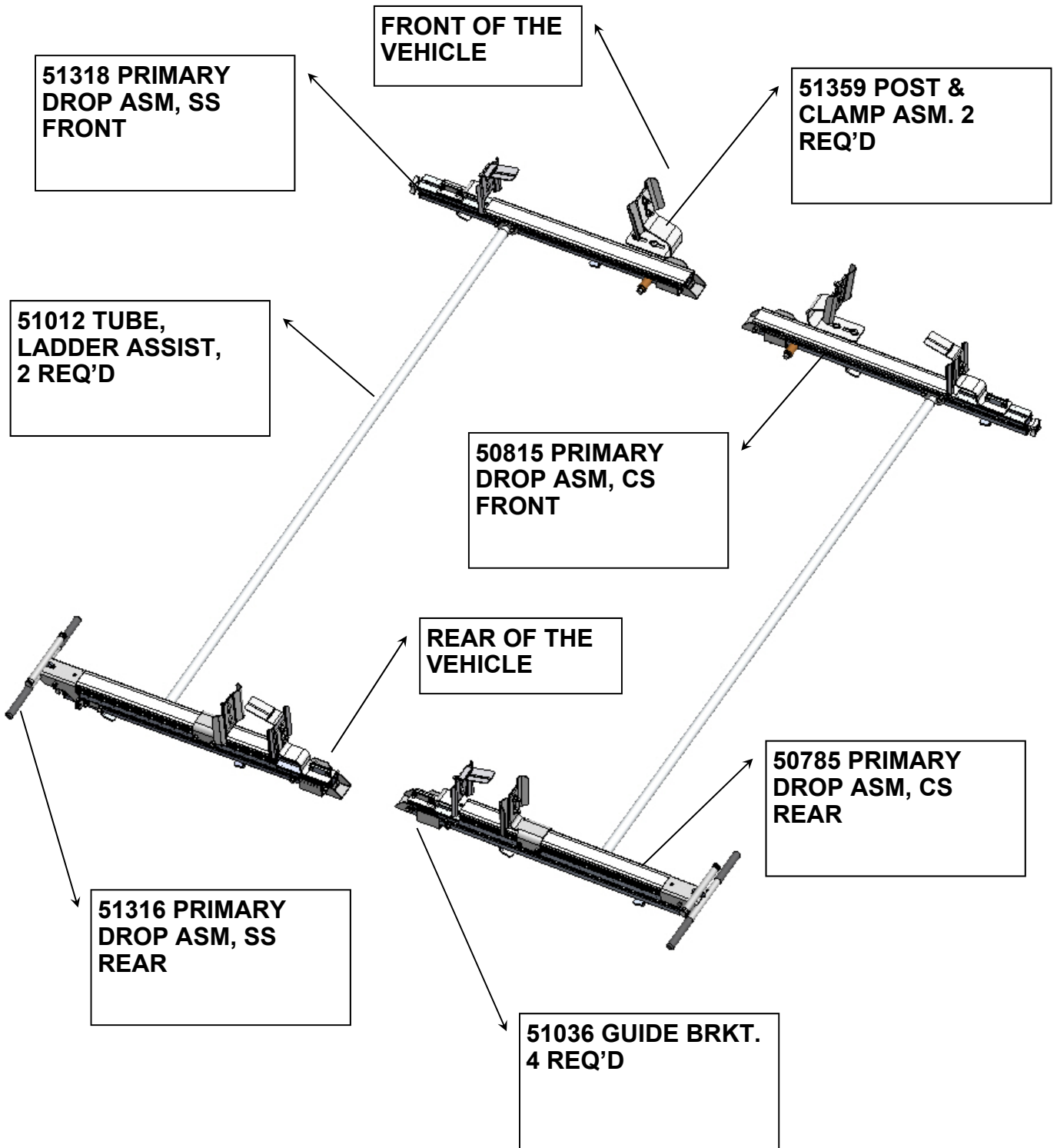

STEP 3 : ASSEMBLE BRACKETS TO THE FRONT CROSS BOW

NOTE: ITEM 51036 WILL VARY APPEARANCE AS EITHER VIEW OF 54178 SHOWN BELOW.

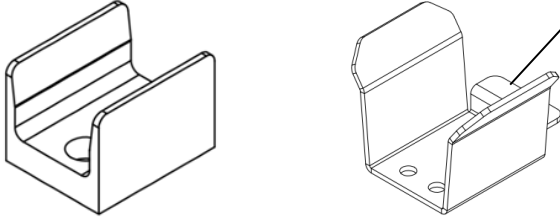

IF USING THIS STYLE, ENSURE THE REST FLANGE IS MOUNTING FACING TO THE OUTSIDE OF THE LADDER RACK! THIS WILL GIVE CLEARANCE FOR A CONDUIT KIT TO BE MOUNTED IN THE CENTER.

FAS0799— 5/16 X .75 HHCS
FAS0588— 5/16 LW
(2) EACH, 4 PLACES
THRU FRONT HOLES OF FRONT BRKTS AND REAR HOLES FOR REAR BRKTS INTO RIVNUTS IN CROSS BOWS

51359 POST & CLAMP ASM
2 PLACES

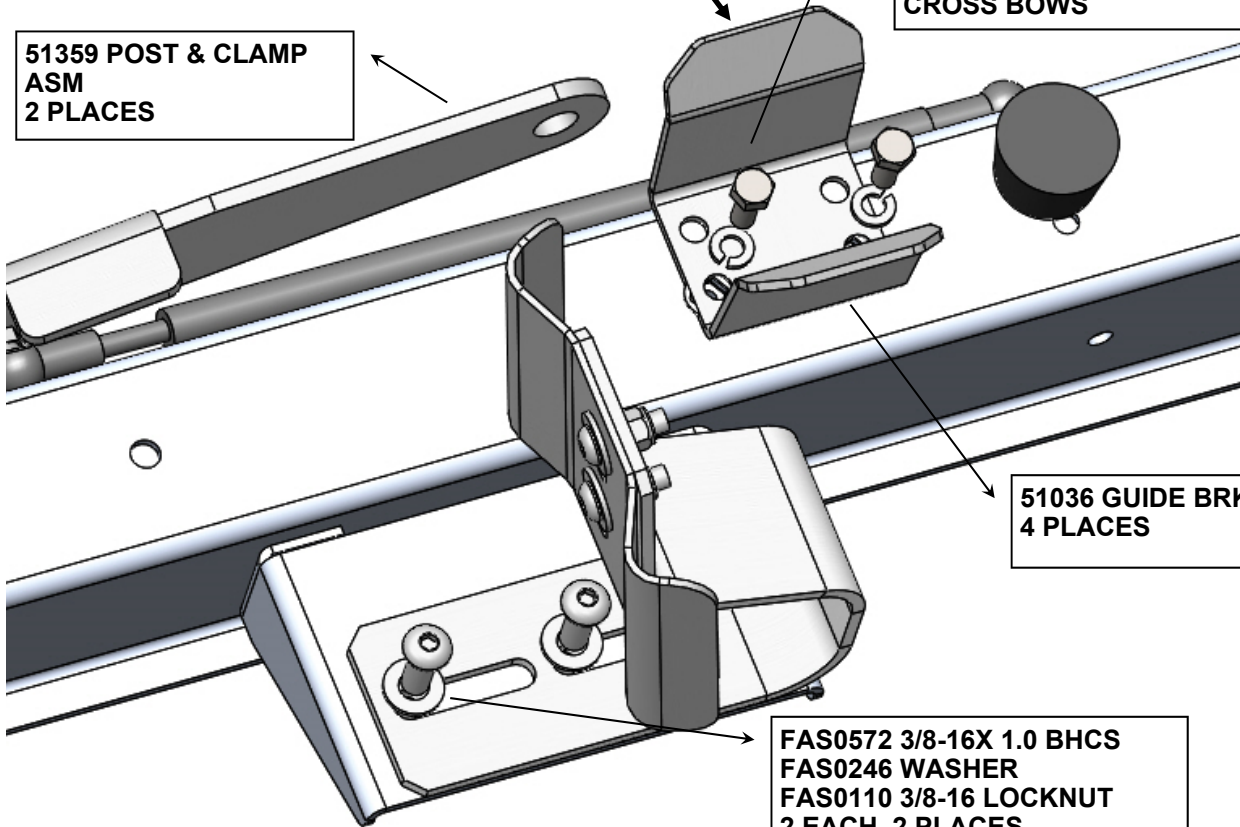

51036 GUIDE BRKT
4 PLACES

FAS0572 3/8-16X 1.0 BHCS
FAS0246 WASHER
FAS0110 3/8-16 LOCKNUT
2 EACH, 2 PLACES

COMPLETED VIEW OF THE FRONT CROSS BOW

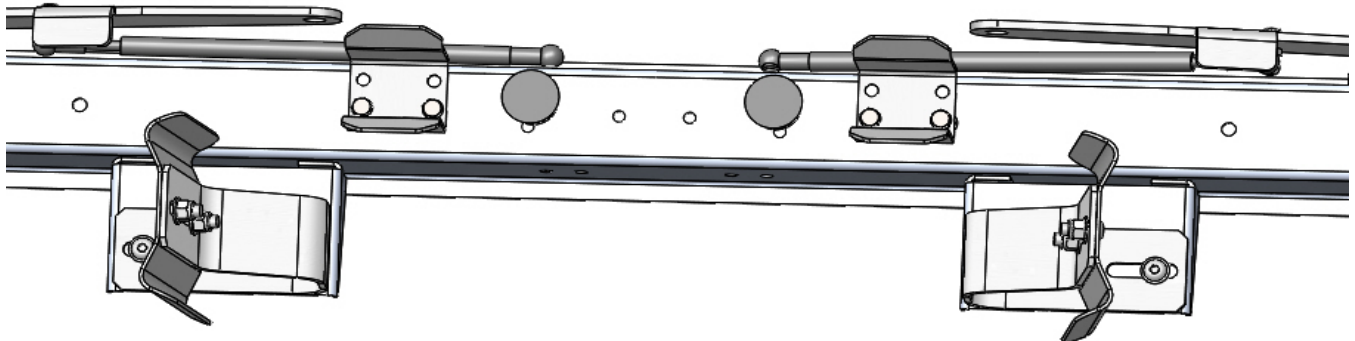

STEP 4 : ASSEMBLE REAR CURB SIDE PRIMARY DROP TO RACK

**SET 50785 PRIMARY DROP ASM, REAR CS IN PLACE ON REAR CROSS BOW.
USE GUIDE ROLLER TO HELP LOAD INTO POSITION**

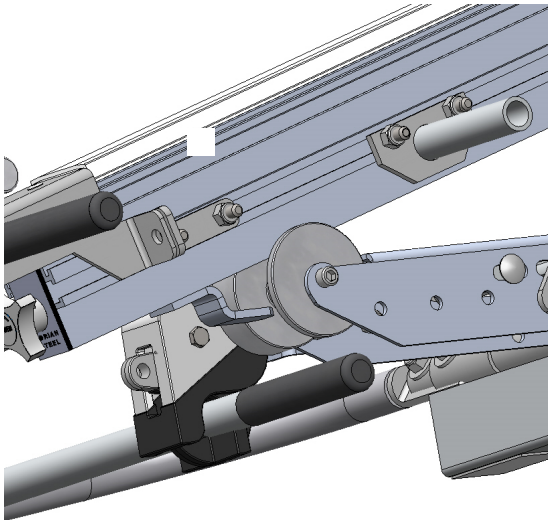

**50785 PRIMARY DROP
ASM CS REAR**

**50785 PRIMARY DROP
ASM, CS REAR**

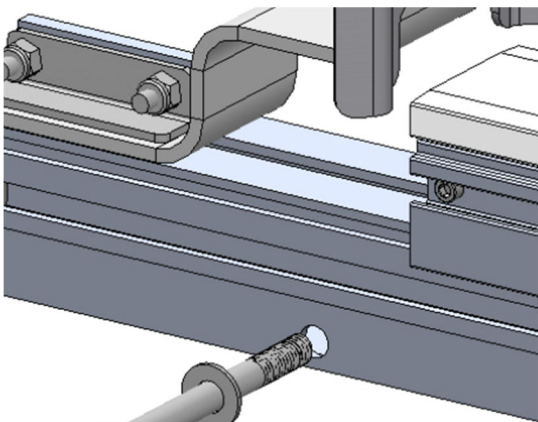
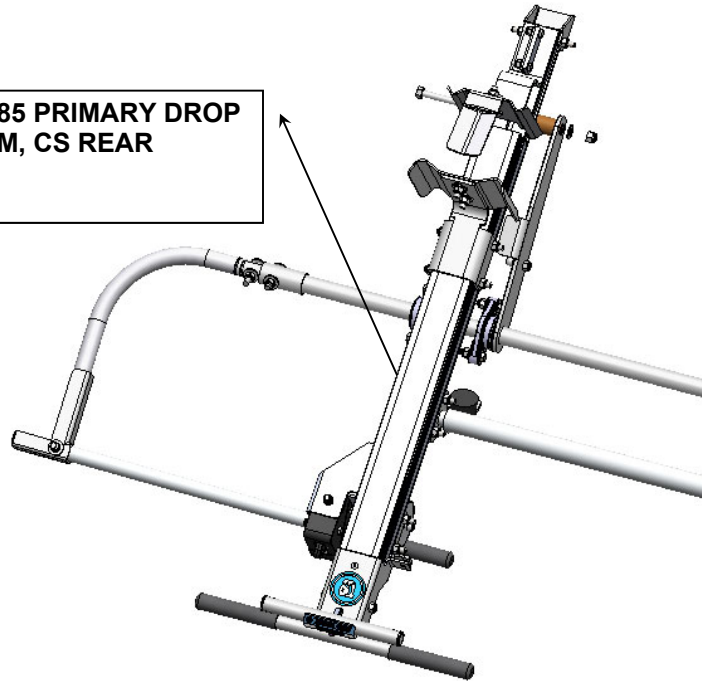

**FAS02826 3/8-16 X 4" HHCS
FAS0246 WASHER**

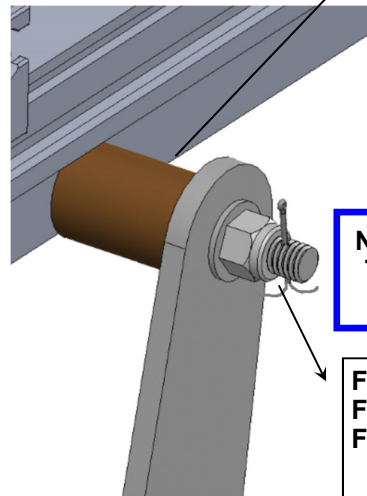

**51034 BRONZE
BUSHING**

**NOTE: TORQUE NYLOCK NUT
TO 20FT.LBS, THEN INSERT/
SECURE THE COTTER PIN.**

**FAS0246 WASHER
FAS0110 3/8-16 NYLOCK NUT
FAS0287—COTTER PIN**

**NOTE: AFTER THE COTTER
PIN IS INSERTED THROUGH
THE BOLT, SPREAD THE PIN
SO IT CAN NOT BE REMOVED.**

STEP 5 : ASSEMBLE FRONT SIDE PRIMARY DROP TO RACK

**SET 50815 PRIMARY DROP ASM, FRONT CS IN PLACE ON FRONT CROSS BOW.
USE GUIDE ROLLER AFTER LADDER ASSIST TUBE IS ON BOTH STUB SHAFTS**

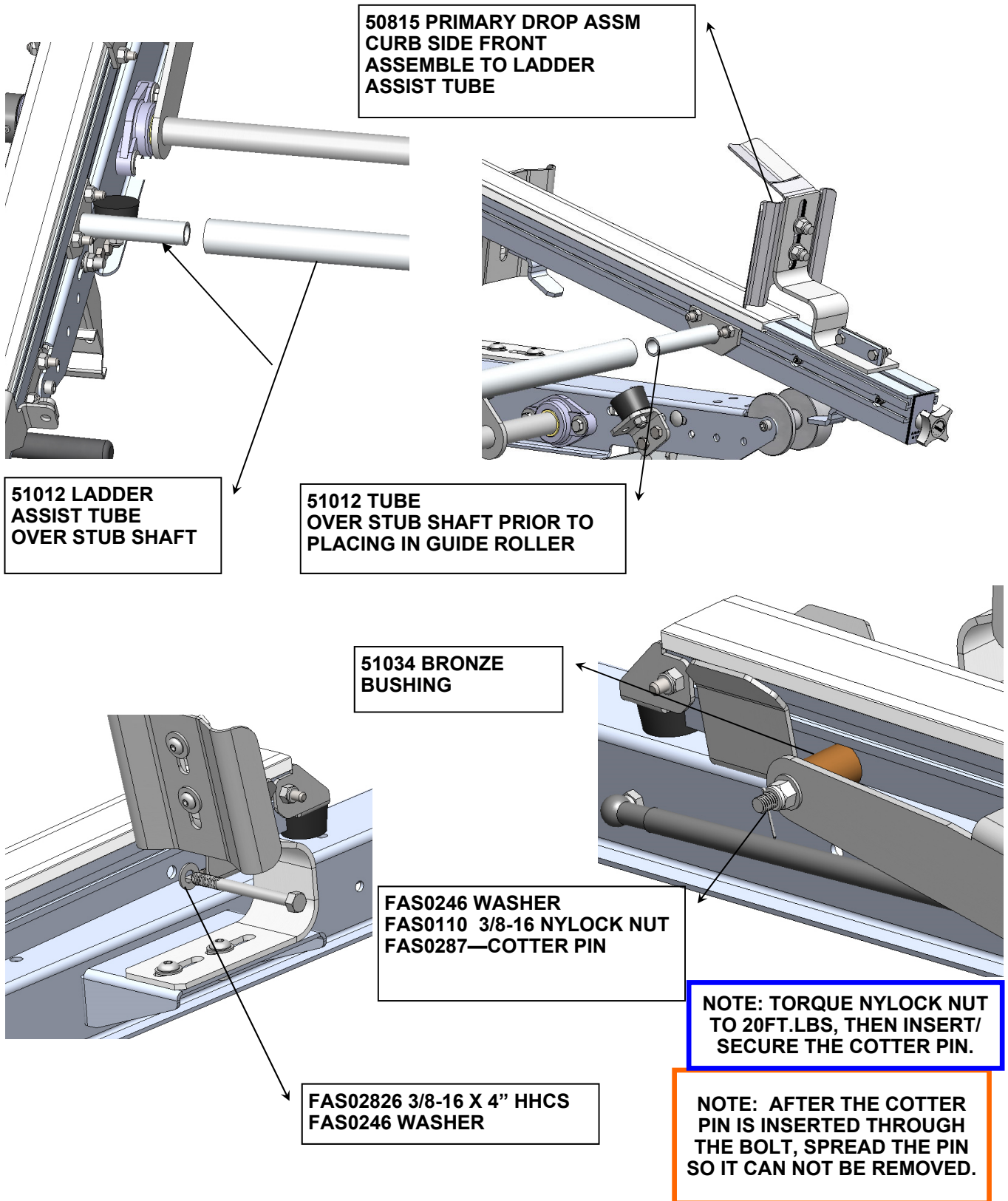



**STEP #6 : FOR A DOUBLE DROP DOWN, INSTALL STREET SIDE USING
STEPS #4 & #5 AS YOUR GUIDE.**

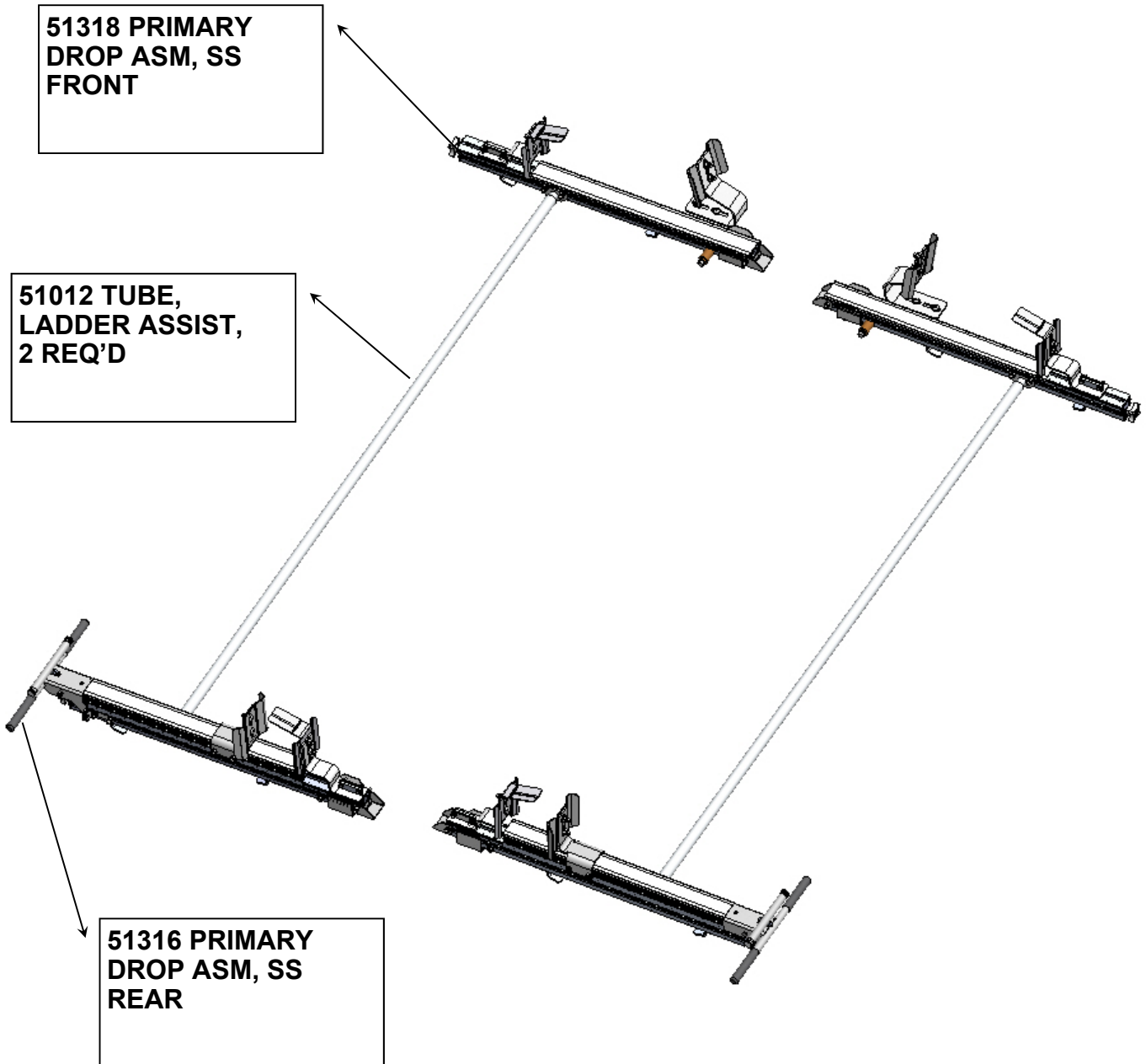

**DOUBLE CHECK ALL FASTENERS LOCATIONS TO BE SURE THAT ALL
FASTENERS ARE TIGHTENED TO SPECIFICATIONS.
YOUR INSTALLATION IS NOW COMPLETE!
STOW THIS COPY IN THE VEHICLE FOR FUTURE REFERENCES!**



**STEP #7 : YOUR DOUBLE DROP DOWN INSTALLATION IS NOW COMPLETE
FOR A COMBO RACK, GO TO STEP 8**



**DOUBLE CHECK ALL FASTENERS LOCATIONS TO BE SURE THAT ALL
FASTENERS ARE TIGHTENED TO SPECIFICATIONS.
YOUR INSTALLATION IS NOW COMPLETE!
STOW THIS COPY IN THE VEHICLE FOR FUTURE REFERENCES!**



STEP #08 : COMBO RACK, FINAL INSTALL- STREET SIDE GRIP LOCK



STEP #9 : COMBO RACK, INSTALL STREET SIDE GRIP LOCK

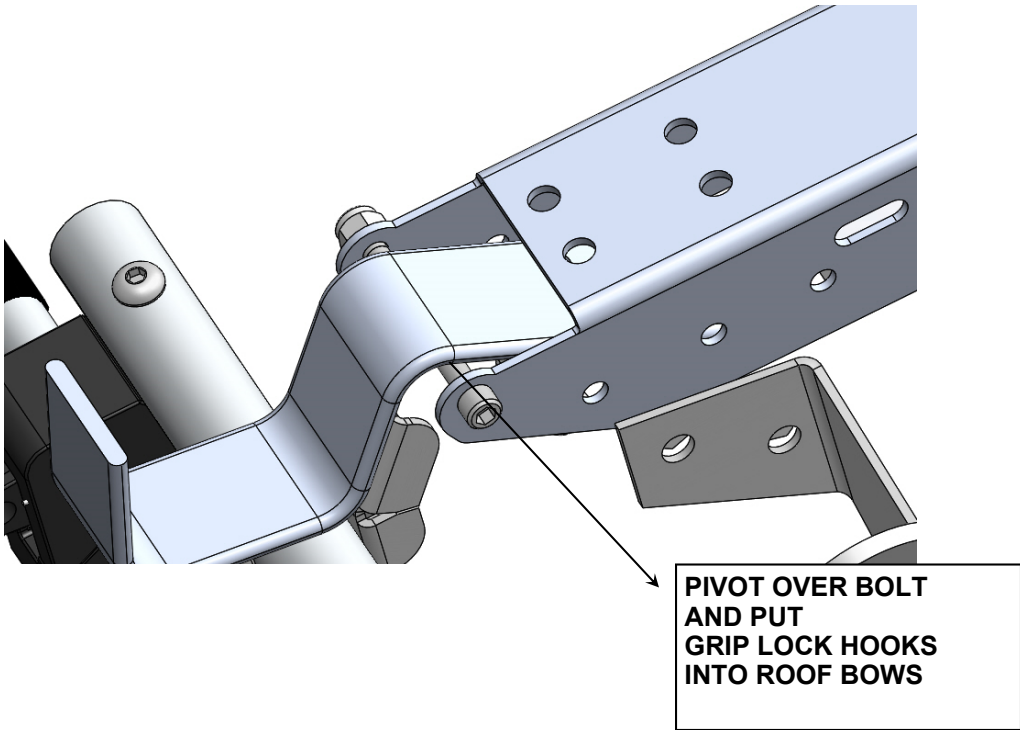

SECOND AND THIRD HOLES !
FAS0799— 5/16 x 3/4 HHCS (2)
FAS0248— NYLOCK (2)

REAR ROOF BOW

FAS0820— 3/8 X 1
LG BHCS (4)
FAS0110— NYLOCK (4)

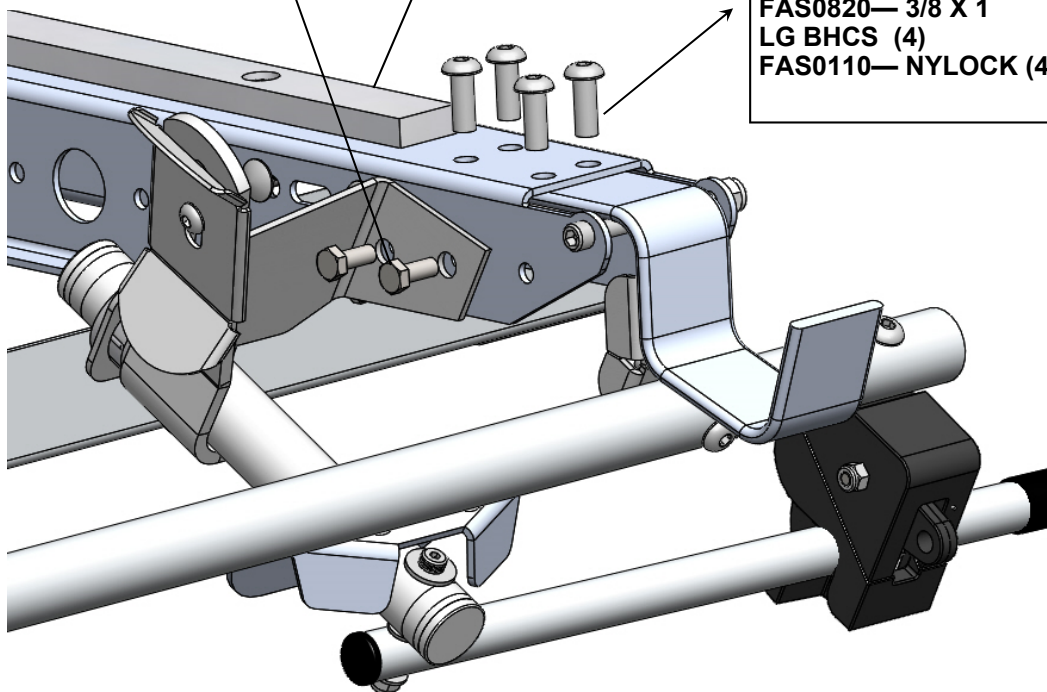

STEP #10: FRONT ROOF BOW ASSEMBLY –STREET SIDE

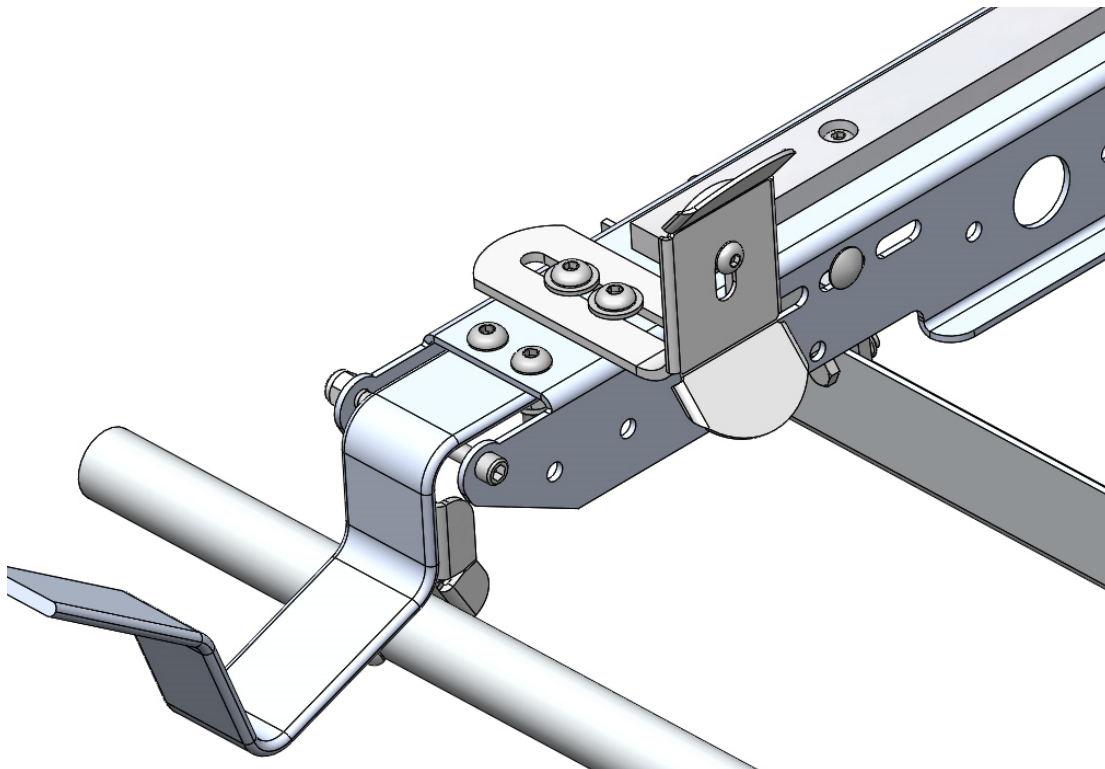
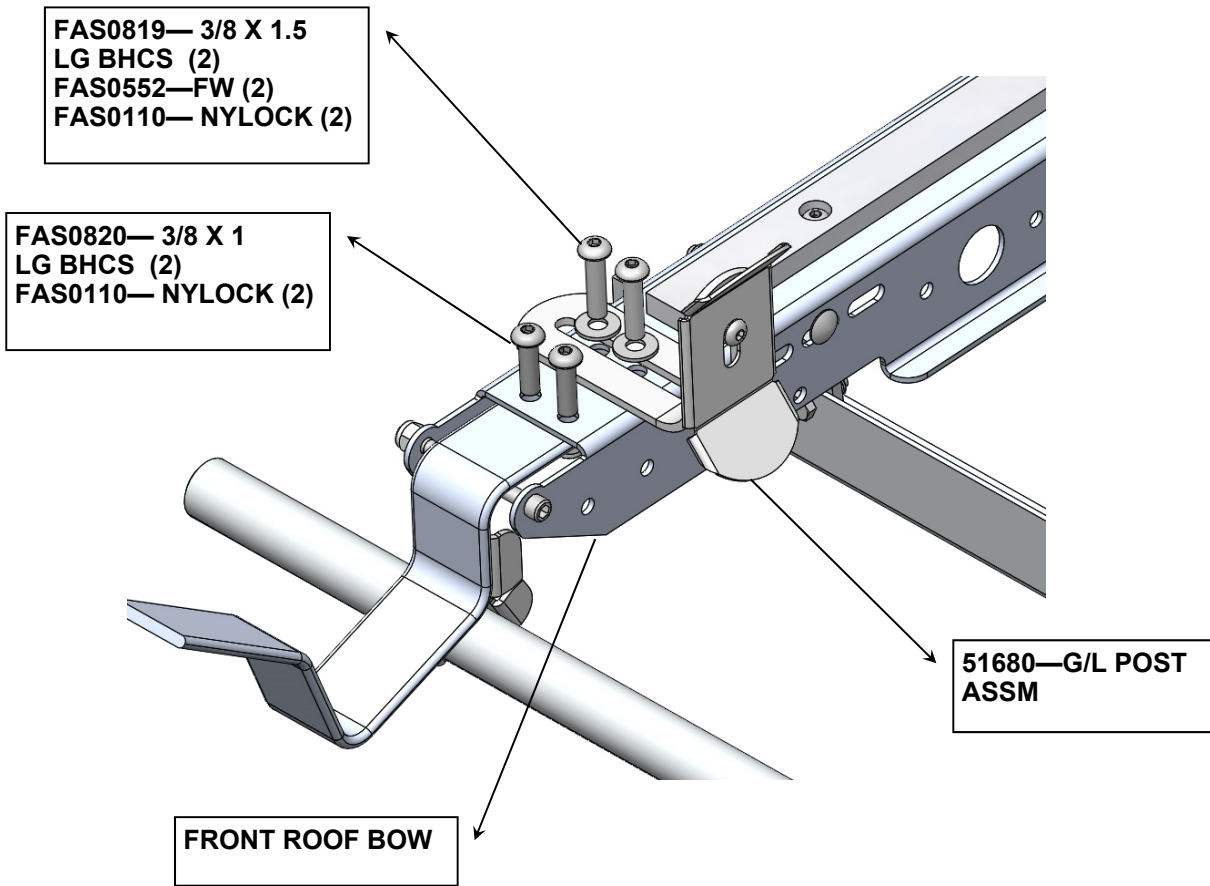

STEP #23 : YOUR DROP DOWN COMBO INSTALLATION IS NOW COMPLETE



**DOUBLE CHECK ALL FASTENERS LOCATIONS TO BE SURE THAT ALL
FASTENERS ARE TIGHTENED TO SPECIFICATIONS.
YOUR INSTALLATION IS NOW COMPLETE!
STOW THIS COPY IN THE VEHICLE FOR FUTURE REFERENCES!**

**REAR CLAMP PAD MOVES TOWARDS CURB TO
TIGHTEN LADDER TO RACK**

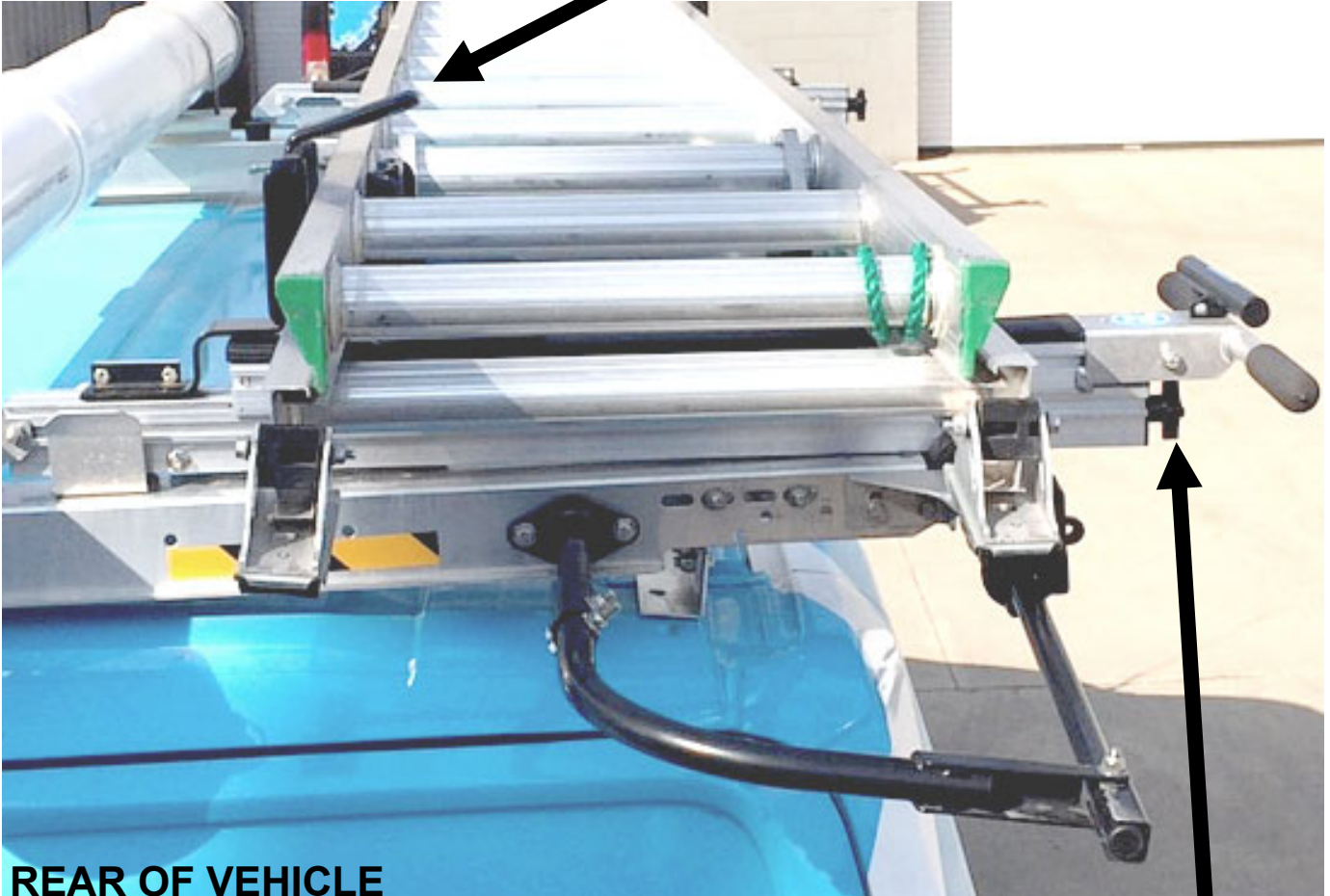

REAR OF VEHICLE



**TURN KNOB TO ADJUST TO
YOUR LADDER.**

**DO NOT OVER TIGHTEN!
CLAMP PAD SHOULD JUST
TOUCH THE LADDER.**

DDL61 Series Final Adjustment Instruction (GMFSV / Ford Transit)

Proper Clamp Pad Locations

Below is the proper way to clamp the ladder to the vehicle (highlighted in green)

How to inspect for this: Properly placed clamp pads should be in close proximity to each other to allow the clamp pads to securely retain the ladder from side to side motion and front to back motion.

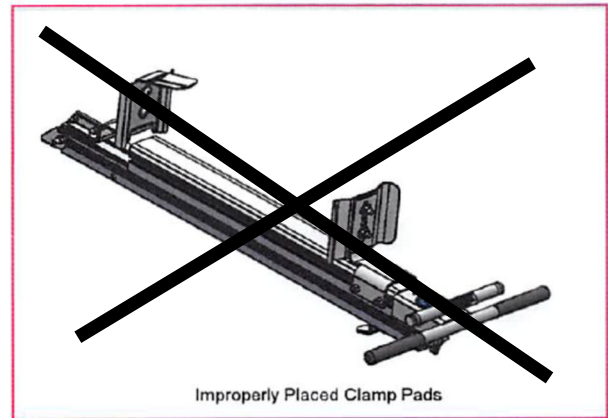
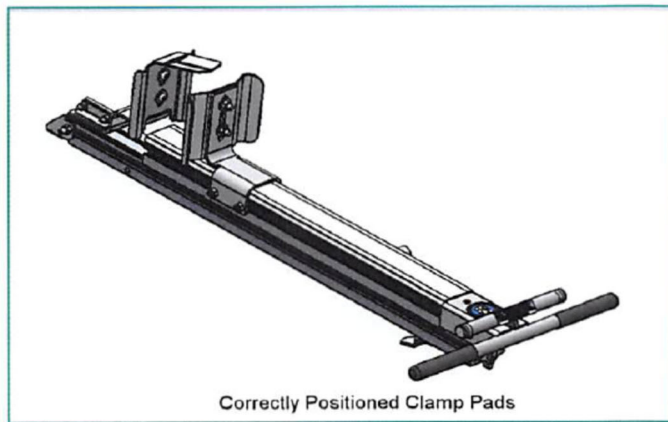

Above is the wrong way to clamp the ladder to the vehicle

**FRONT CLAMP PAD MOVES TOWARDS STREET
TO TIGHTEN LADDER TO RACK**



**TURN KNOB TO ADJUST TO
YOUR LADDER.**

**DO NOT OVER TIGHTEN!
CLAMP PAD SHOULD JUST
TOUCH THE LADDER.**



DDL61 Series Final Adjustment Instruction (GMFSV / Ford Transit)

**DOUBLE CHECK ALL FASTENERS LOCATIONS TO BE SURE THAT ALL FASTENERS ARE
TIGHTENED TO SPECIFICATIONS.**

YOUR INSTALLATION IS NOW COMPLETE!

STOW THIS COPY IN THE VEHICLE FOR FUTURE REFERENCES!

STEP #10A: HOW TO ADJUST THE CLAMP PADS

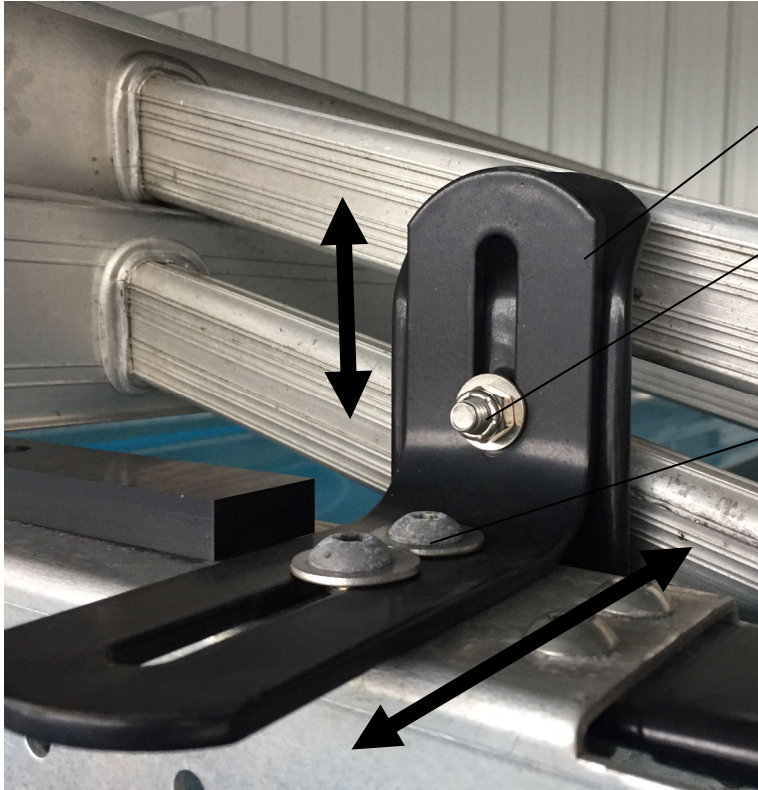

FRONT BRACKET

ADJUST VERTICALLY TO YOUR LADDER

ALL OF THE HORIZONTAL ADJUSTMENT IS IN THIS BRACKET.

REAR LOCKING PIVOT BRACKET

ADJUST VERTICALLY TO YOUR LADDER. SHOWING A STEP LADDER

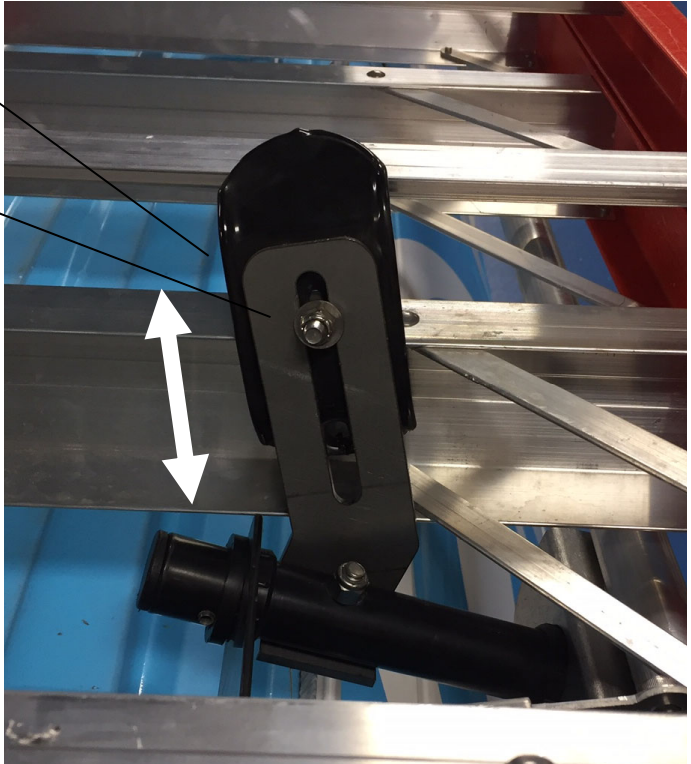

**DOUBLE CHECK ALL FASTENERS LOCATIONS TO BE SURE THAT ALL FASTENERS ARE TIGHTENED TO SPECIFICATIONS.
YOUR INSTALLATION IS NOW COMPLETE!
STOW THIS COPY IN THE VEHICLE FOR FUTURE REFERENCES!**

STEP #10B : HOW TO ADJUST THE CLAMP PADS

- A) Load your ladder onto the ladder rack (see page 14) and latch the HANDLE BAR into the HANDLE LATCH.
- B) Now slide the ladder back towards the rear of the vehicle and slide the rear CLAMP BRACKET to fit snug over and against the top ladder rung. ** See bottom illustration for STEP LADDERS ! **
SEE ILLUSTRATION BELOW.
- C) Next slide the FRONT STOP POST at the front of the ladder rack back towards the rear of the vehicle and fit the front CLAMP BRACKET to the top ladder rung the same as the rear.
- D) Firmly tighten both front and rear CLAMP BRACKETS to their posts and tighten snug the FRONT STOP POST to the front CROSS SUPPORT.
- E) Now unlatch the HANDLE BAR and unload your ladder. Next loosen the FRONT STOP POST and slide it out towards the rear of the vehicle 1/2" and FIRMLY RETIGHTEN !
YOUR LADDER RACK SHOULD NOW BE ADJUSTED FOR YOUR LADDER.

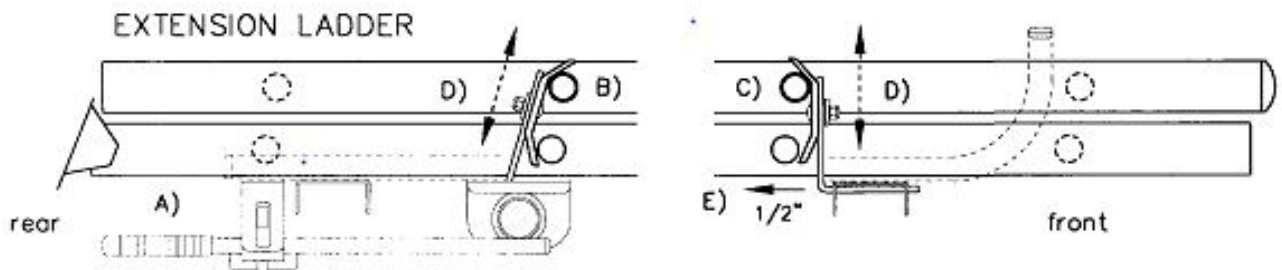

CAUTION: Never clamp up the first step and the head of the STEP LADDER !

Front CLAMP BRACKET must be attached like this !

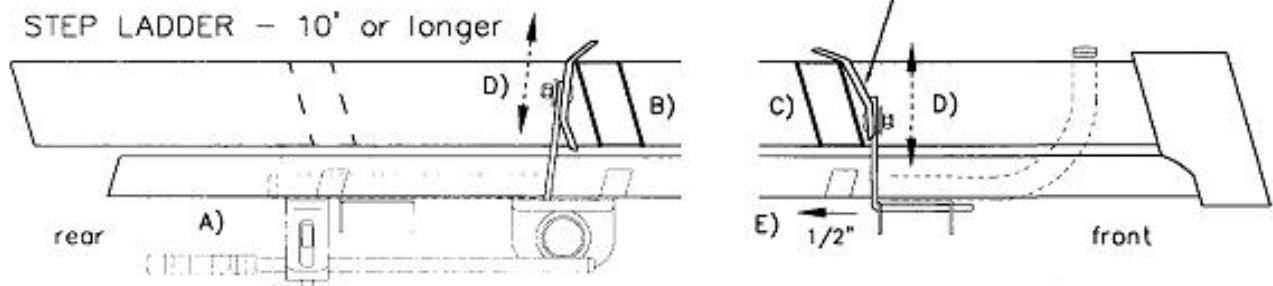

**DOUBLE CHECK ALL FASTENERS LOCATIONS TO BE SURE THAT ALL FASTENERS ARE TIGHTENED TO SPECIFICATIONS.
YOUR INSTALLATION IS NOW COMPLETE!
STOW THIS COPY IN THE VEHICLE FOR FUTURE REFERENCES!**

Introduction / Comments:

THIS DROP DOWN UNIT IS CURB SIDE, STREET SIDE SPECIFIC. THE DROP DOWN IS FOR LOW ROOF VEHICLES, THESE INSTRUCTIONS WILL BE SHOWING THE FORD TRANSIT FOR THE VEHICLE REPRESENTATION. THIS DROP DOWN LADDER RACK IS DESIGNED TO ADAPT TO AN ADRIAN STEEL CROSS BOW KIT FOR VARIOUS STANDARD ROOF VEHICLES.

Note:

It is advised that all fasteners used in this assembly and installation of this Rack should be checked for tightness at the following intervals: @ 2-weeks and again @ 6-weeks of operation. This preventive maintenance step must be completed to ensure your package gives you long service life.

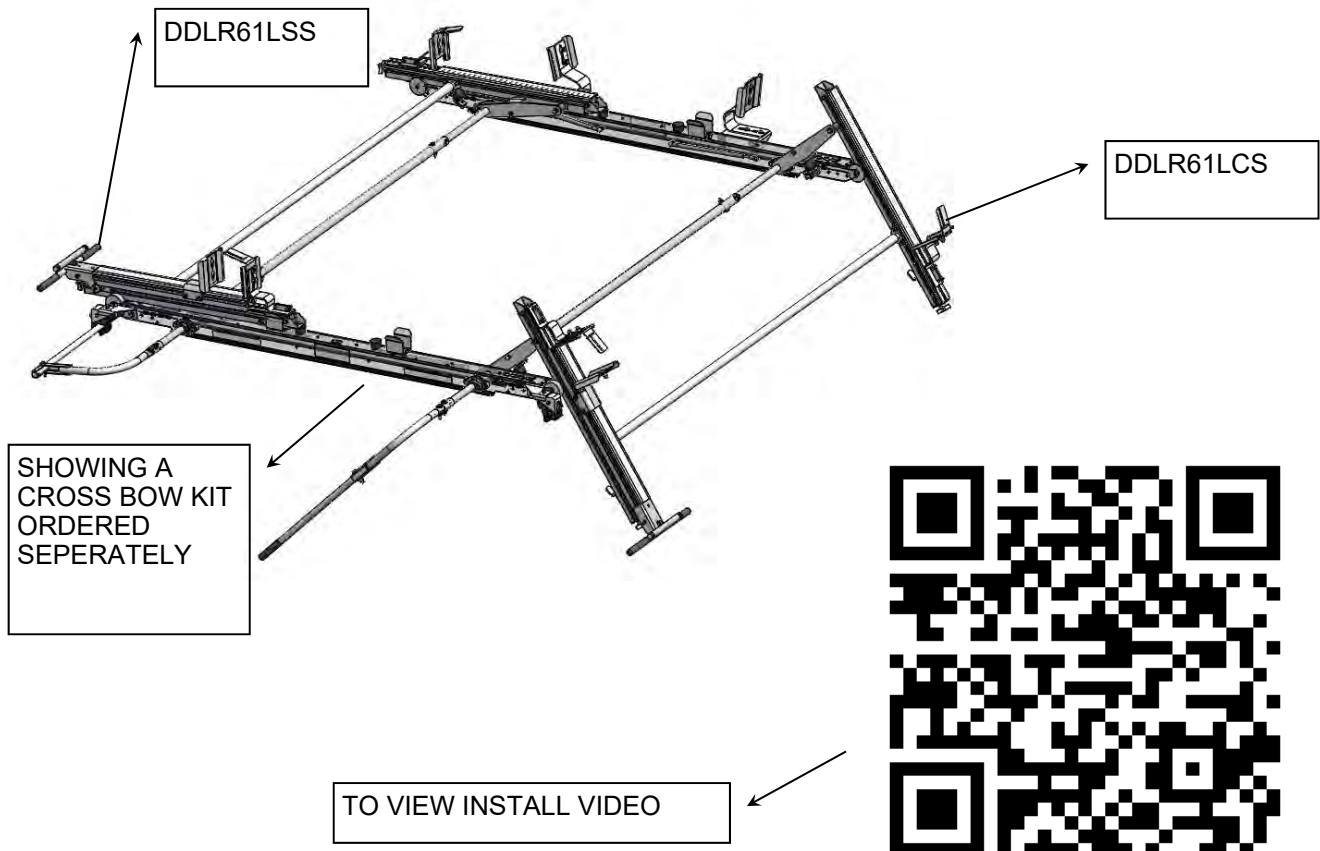

**DDL61FTL / DDL63FTL
DROP DOWN LADDER RACK, STREET, CURB
VARIOUS LOW ROOF VANS**

- PRECAUTIONS -





 **CAUTION** 
**THE USE OF AIR IMPACT TOOLS CAN
OVER-TORQUE FASTENERS AND
CAUSE FASTENER FAILURE!**



 **CAUTION** 
**ALL INSTALLATION HOLES SHOULD BE SEALED
WITH SILICON OR BUTYL SEALANT TO PREVENT
EXHAUST FUMES FROM ENTERING THE VEHICLE!**



 **DANGER** 
**INSPECT FOR FUEL TANK, FUEL LINES, BRAKE LINES, HIGH
VOLTAGE BATTERIES AND ELECTRICAL LINES PRIOR TO
DRILLING TO AVOID DAMAGING CRITICAL VEHICLE SYSTEMS
OR INJURY TO INSTALLER DURING INSTALLATION PROCESS!**



 **CAUTION** 
**TO AVOID DAMAGING THE VEHICLE ALWAYS
USE DRILL STOPS WHEN DRILLING ANY IN-
STALLATION HOLES!**



- IMPORTANT WARRANTY REQUIREMENTS -

1. SUBSTITUTING ADRIAN STEEL SPECIFIED FASTENERS FOR ASSEMBLY AND/OR INSTALLATION WILL VOID YOUR PRODUCT WARRANTY.
2. ALL HOLES DRILLED INTO VEHICLE SHOULD HAVE THE RAW METAL EDGES SEALED WITH A SELF-ETCHING PRIMER TO RESIST CORROSION AND POTENTIAL FASTENER POINT FAILURE.
3. ALL FASTENERS USED IN THE INSTALLATION OF THIS PRODUCT SHOULD BE TIGHTENED TO THE TORQUE(S) SPECIFIED IN THESE INSTRUCTIONS.
4. THESE INSTRUCTIONS SHOULD BE KEPT WITH THE VEHICLE.

THE BASIC TOOLS NEEDED FOR MOST INSTALLATIONS



DRILL



DRILL BIT WITH
STOP



RATCHET, SOCKETS
AND/OR WRENCHES



SCREWDRIVERS



MEASURING TAPE

ADDITIONAL TOOLS MAY BE NEEDED FOR THIS INSTALLATION AND THEY WILL BE IDENTIFIED IN THE STEPS THAT FOLLOW.

BAG51043 - DROP DOWN ASSEMBLY BAG

ITEM NO.	PART NUMBER	DESCRIPTION	QTY.
1	BAG0507-A	5" x 7" 3MIL AUTOBAG	1
2	FAS0248	Nut, Nylon Insert Lock, 5/16-18 SST	31
3	34927-0	Ball Stud, Damper	4
4	34924-0	Neoprene Bumper	4
5	FAS0552	Washer, Flat, 5/16, SST	23
6	FAS0830	Screw, Hex Hd, 5/16-18 X 1.25 SS	7
7	FAS0799	Screw, Hex Hd, 5/16-18x0.75 SS	8
8	FAS0179	Screw, Hex Hd, 5/16-18x2.00 STAINLESS STEEL	6
9	FAS0811	SCREW,CAP, 5/16-18X3.50 SS	2
10	26618-0	Silicone Sealant	1
11	34928-0	Clip, Suspa P/N P68-00019	4
12	05586-0	Butyl Tape, T224 -1/2"X 1' Roll	1

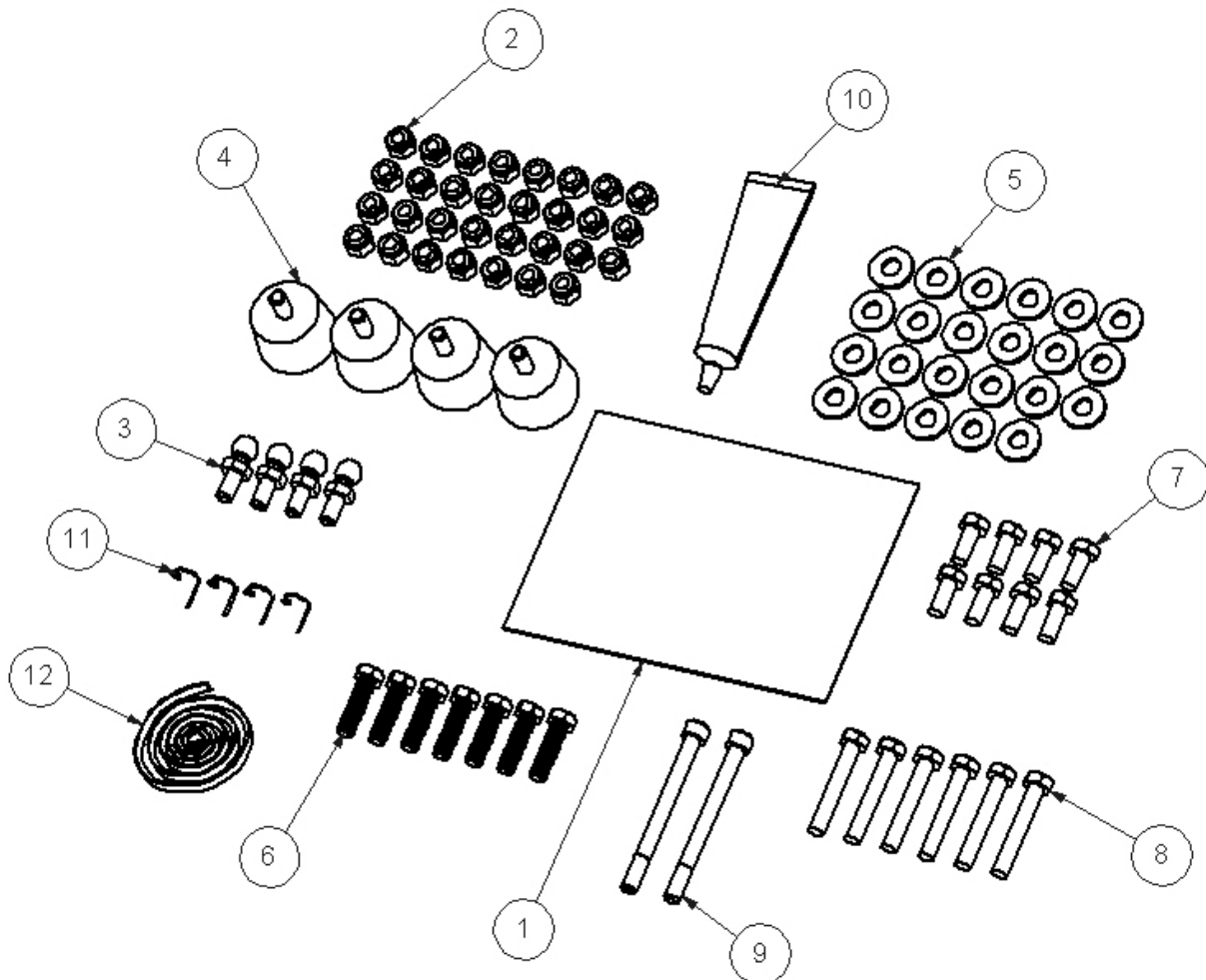

BAG51041—FINAL ASSEMBLY FASTENER BAG

ITEM NO.	PART NUMBER	DESCRIPTION	QTY.
1	BAG0507-A	5" x 7" 3MIL AUTOBAG	1
2	FAS0246	Washer, Flat, 3/8, HRD, ZN	6
3	FAS0799	Screw, Hex Hd, 5/16-18x0.75 SS	4
4	FAS0110	Nut,Hex Nylk 3/8-16 SS W	4
5	FAS0572	Screw, Button Hd Hex Soc, 3/8-16x1.00 NI-ZN	2
6	FAS0588	Washer, Lock, Split, 5/16, SS	4
7	FAS0286	SCREW, HHCS, 3/8-16x4, SS	2
8	FAS0287	COTTER PIN, 1/16DIA X 1"LG, SS	2

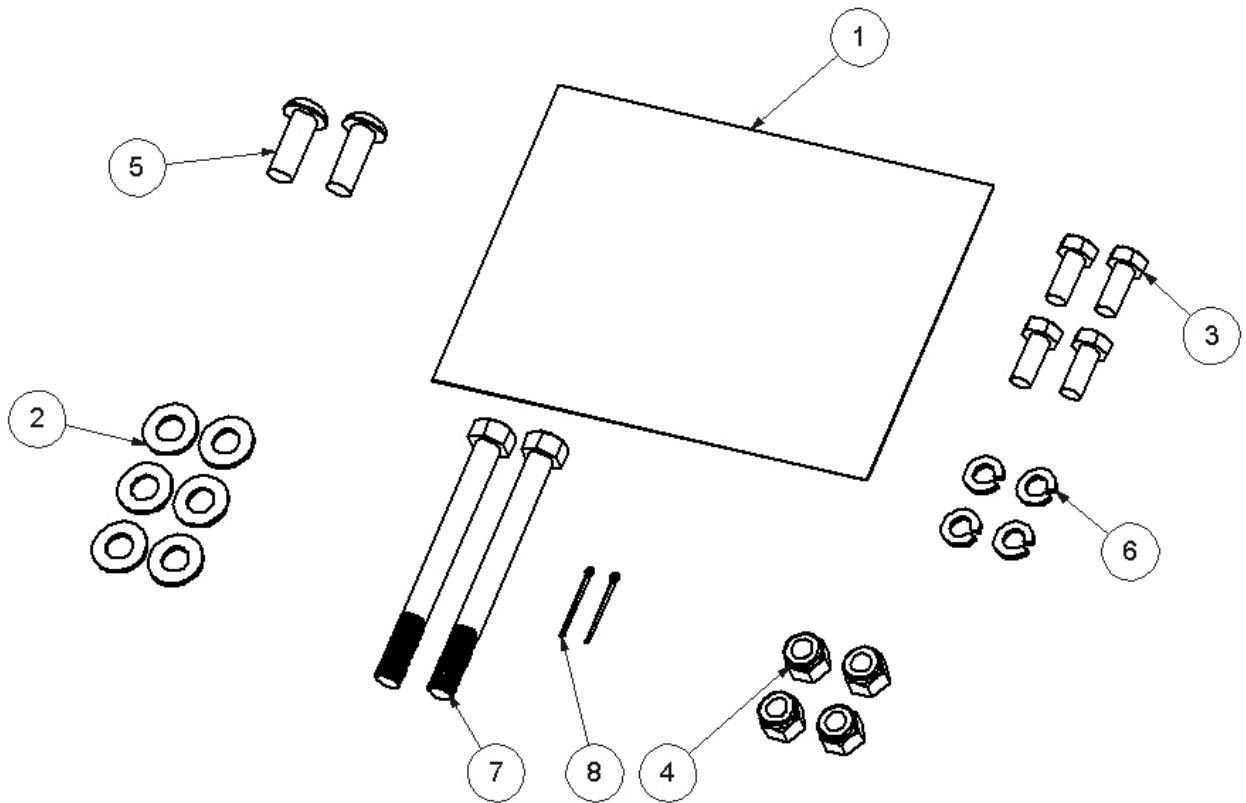

STEP #1 : ASSEMBLE CURB SIDE REAR CROSS BOW

REAR OF THE VAN

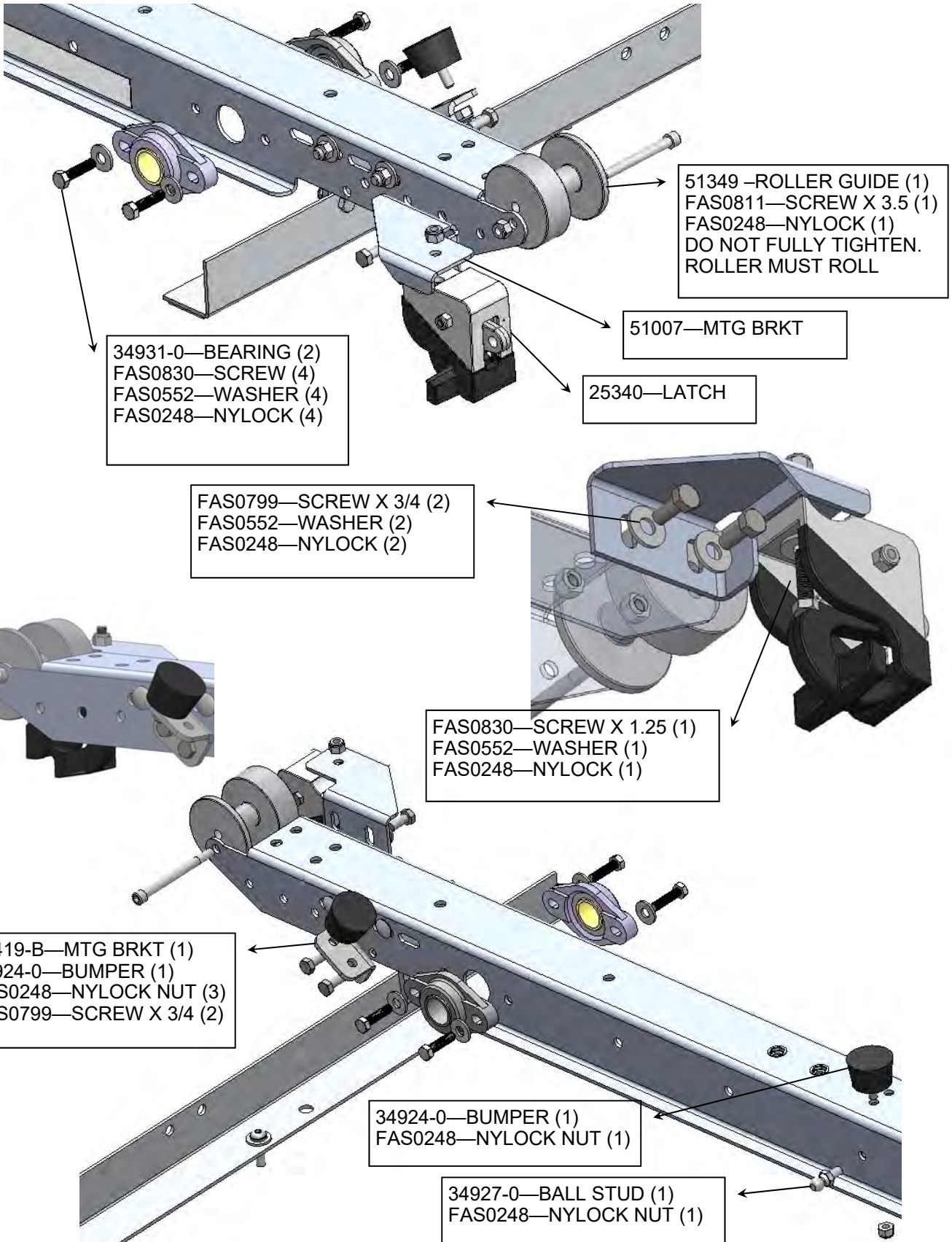



STEP #2 : ASSEMBLE CURB SIDE FRONT CROSS BOW. DO NOT ATTACH TO THE RAIL YET.

- 50828—MTG PLATE (1)
- FAS0799 -SCREW X 3/4 (2)
- FAS0552—WASHER (2)
- FAS0248—NYLOCK (2)

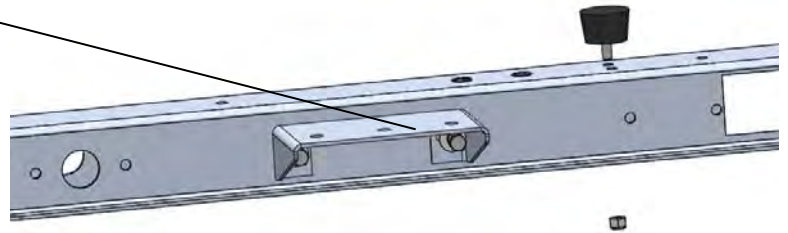

- 34924-0—BUMPER (1)
- FAS0248—NYLOCK NUT (1)

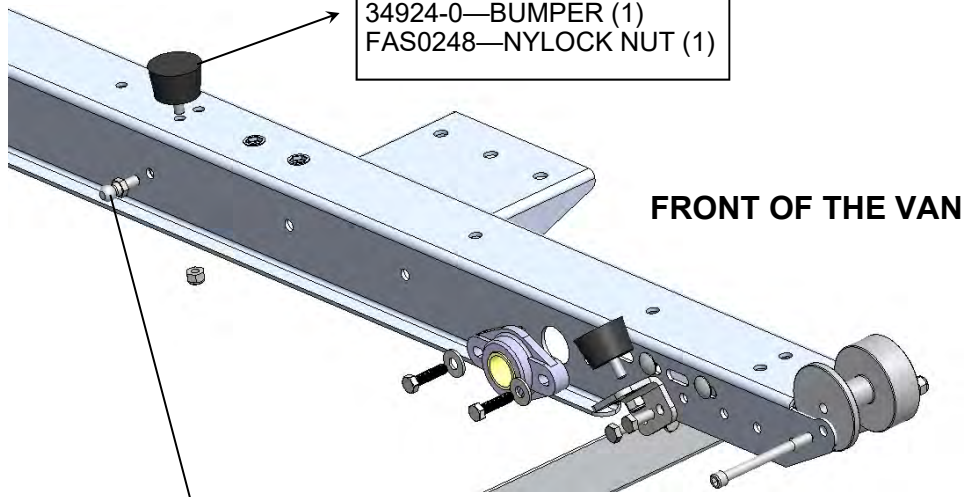

- 34927-0—BALL STUD (1)
- FAS0248—NYLOCK NUT (1)

- 51349 –ROLLER GUIDE (1)
- FAS0811—SCREW X 3.5 (1)
- FAS0248—NYLOCK (1)
- DO NOT FULLY TIGHTEN. ROLLER MUST ROLL

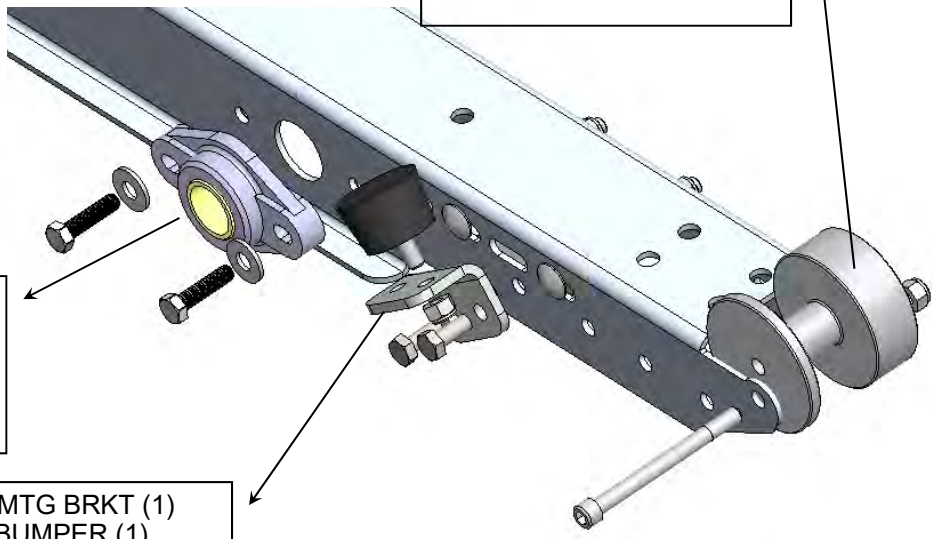

- 34931-0—BEARING (1)
- FAS0830—SCREW (2)
- FAS0552—WASHER (2)
- FAS0248—NYLOCK (2)

- 40419-B—MTG BRKT (1)
- 34924-0—BUMPER (1)
- FAS0248—NYLOCK NUT (3)
- FAS0799—SCREW X 3/4 (2)

STEP #3 : ASSEMBLE CURB SIDE PIVOT DRIVE TO THE CROSS BOWS

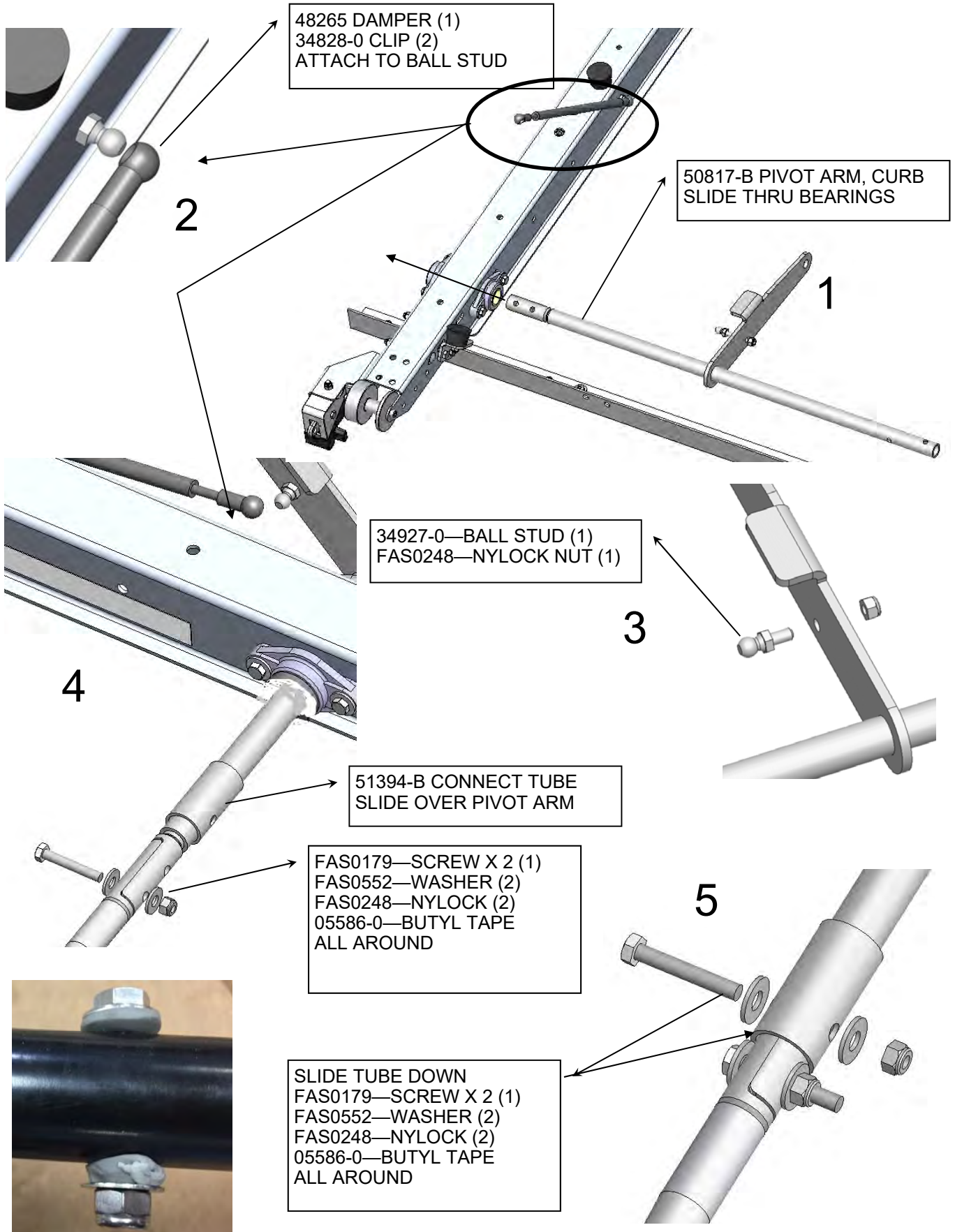

STEP #4A : ASSEMBLE CURB SIDE PIVOT DRIVE AT REAR OF VEHICLE.



APPLY SILICONE BEAD (2) PLACES ALL AROUND ON EACH PIVOT ARM

1

50819-B TORSION TUBE OVER BOTH TUBES

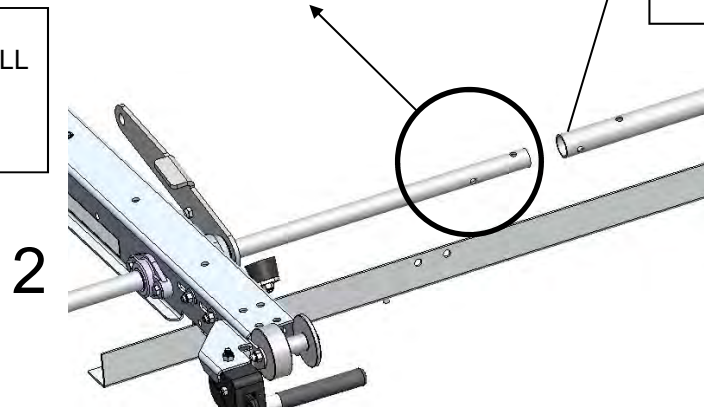

2



3

05586-0 BUTYL TAPE ALL AROUND

FAS0179—SCREW X 2 (2)
FAS0552—WASHER (4)
FAS0248—NYLOCK NUT (2)

26618-0—SILOCONE ALL AROUND

4



FINISHED CONNECTION

STEP #4B : ASSEMBLE CURB SIDE PIVOT DRIVE AT FRONT OF VEHICLE



APPLY SILICONE BEAD (2) PLACES ALL AROUND ON EACH PIVOT ARM

5

50817-B—PIVOT ARM, CS

6

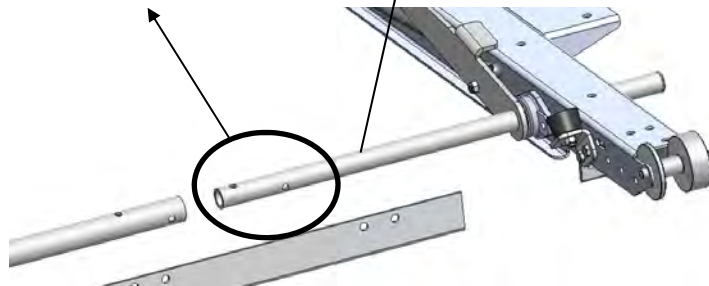

7

05586-0 BUTYL TAPE ALL AROUND

FAS0179—SCREW X 2 (4)
FAS0552—WASHER (8)
FAS0248—NYLOCK NUT (4)

26618-0—SILOCONE ALL AROUND

8



FINISHED CONNECTION

STEP #4C : ASSEMBLE CURB SIDE PIVOT DRIVE TO THE CROSS BOWS

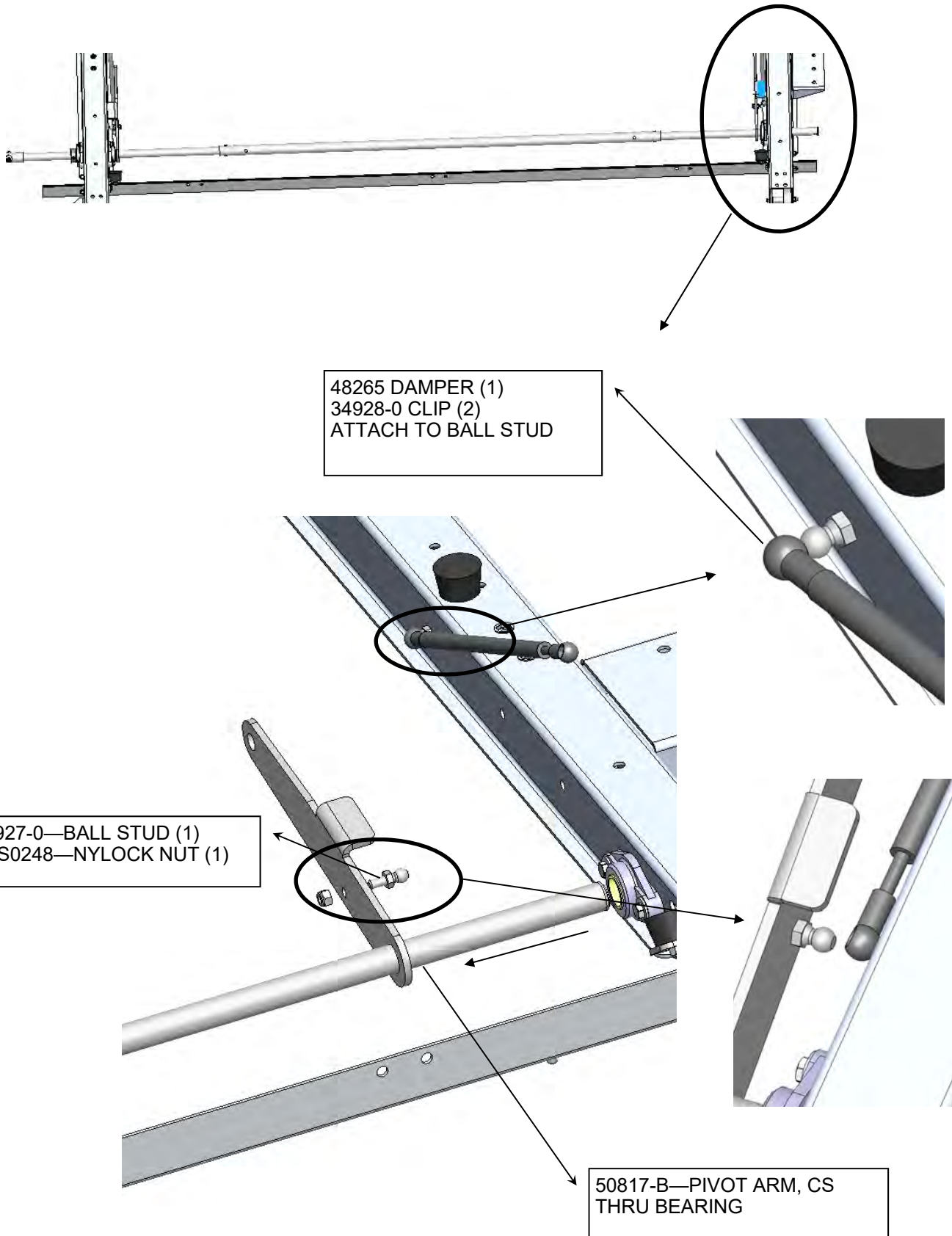



STEP #5 : THIS IS THE FINISHED CURB SIDE PIVOT DRIVE
-CONTINUE TO STEP #11 FOR A COMPLETE ASSEMBLY / INSTALL
-CONTINUE TO STEP #6 FOR THE STREET SIDE PIVOT DRIVE.

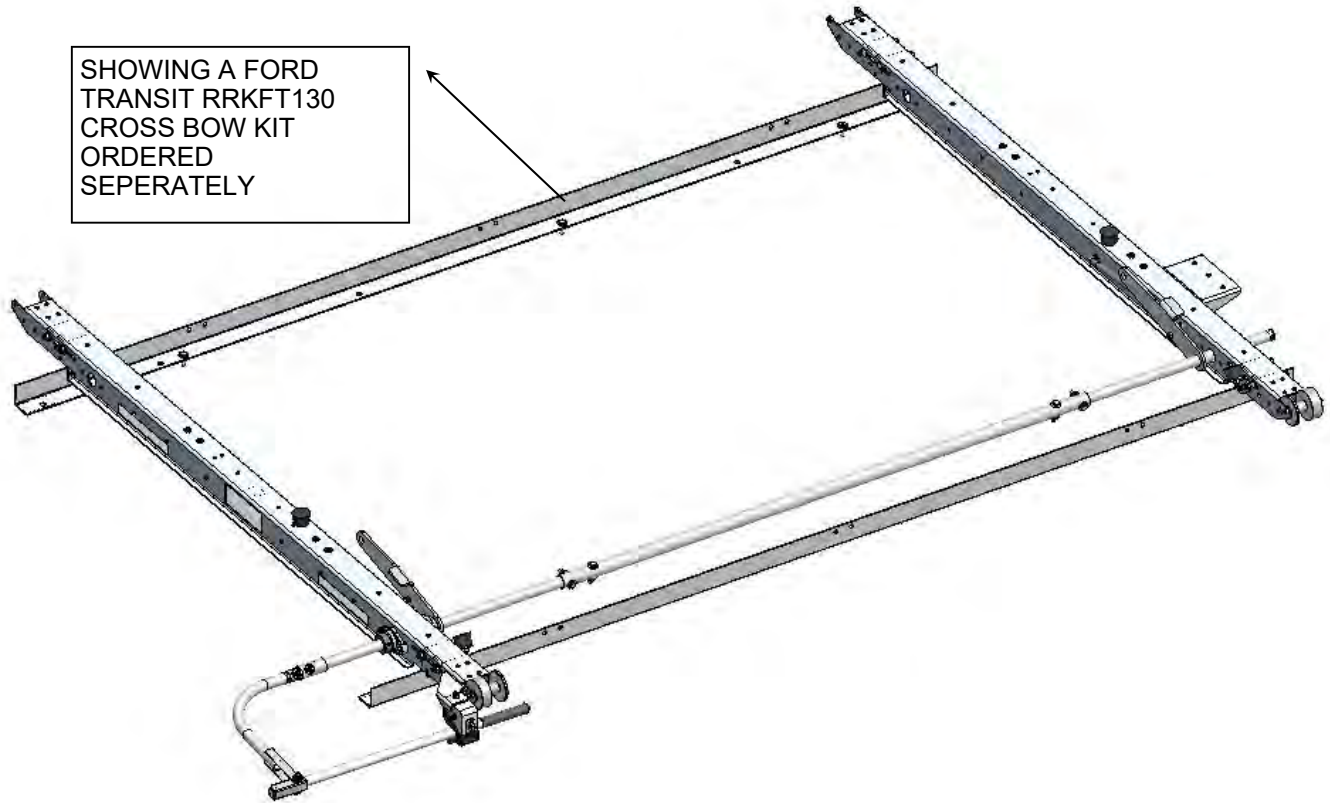

STEP #6 : THIS IS THE FINISHED CURB SIDE PIVOT DRIVE.
-CONTINUE TO STEP #7 FOR A COMPLETE ASSEMBLY / INSTALL
-CONTINUE TO STEP #9 FOR THE STREET SIDE PIVOT DRIVE



STEP #6 THRU #9: ASSEMBLE STREET SIDE REAR CROSS BOW

USE STEPS #1 THRU #4 AS YOUR GUIDE—FINAL SHIP THRU STREET SIDE ASSEMBLY SHOWN BELOW

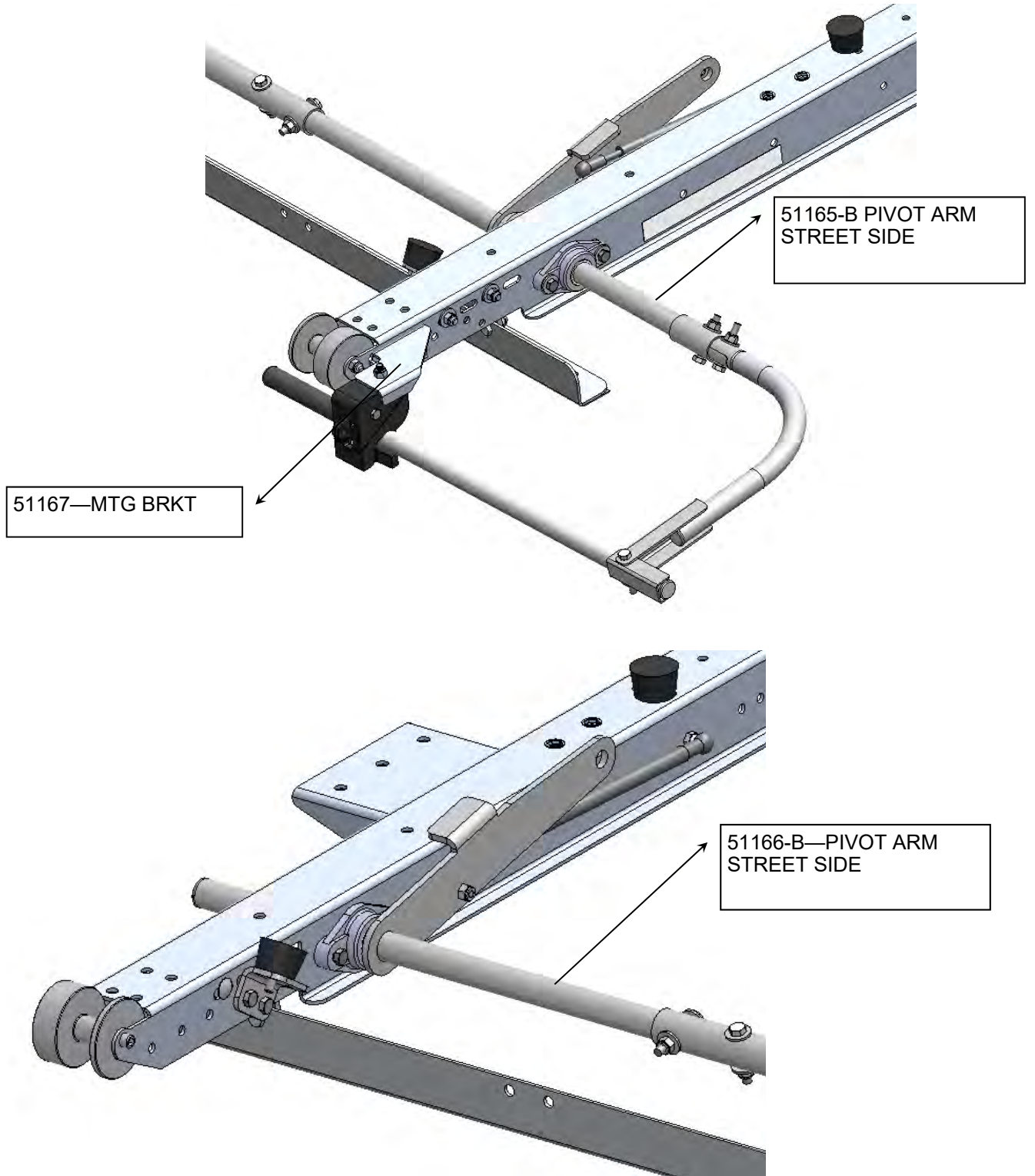

STEP #10 : THIS IS THE FINISHED CURB AND STREET SIDE PIVOT DRIVE
-CONTINUE TO STEP #11 FOR A COMPLETE ASSEMBLY / INSTALL



STEP #10 : THIS IS THE FINISHED CURB AND STREET SIDE PIVOT DRIVE.
-CONTINUE TO STEP #11 FOR A COMPLETE ASSEMBLY / INSTALL



STEP #11 - THIS IS THE FINAL ASSEMBLY, SHOWING THE CURB AND STREET SIDE DROP DOWN COMPONENTS

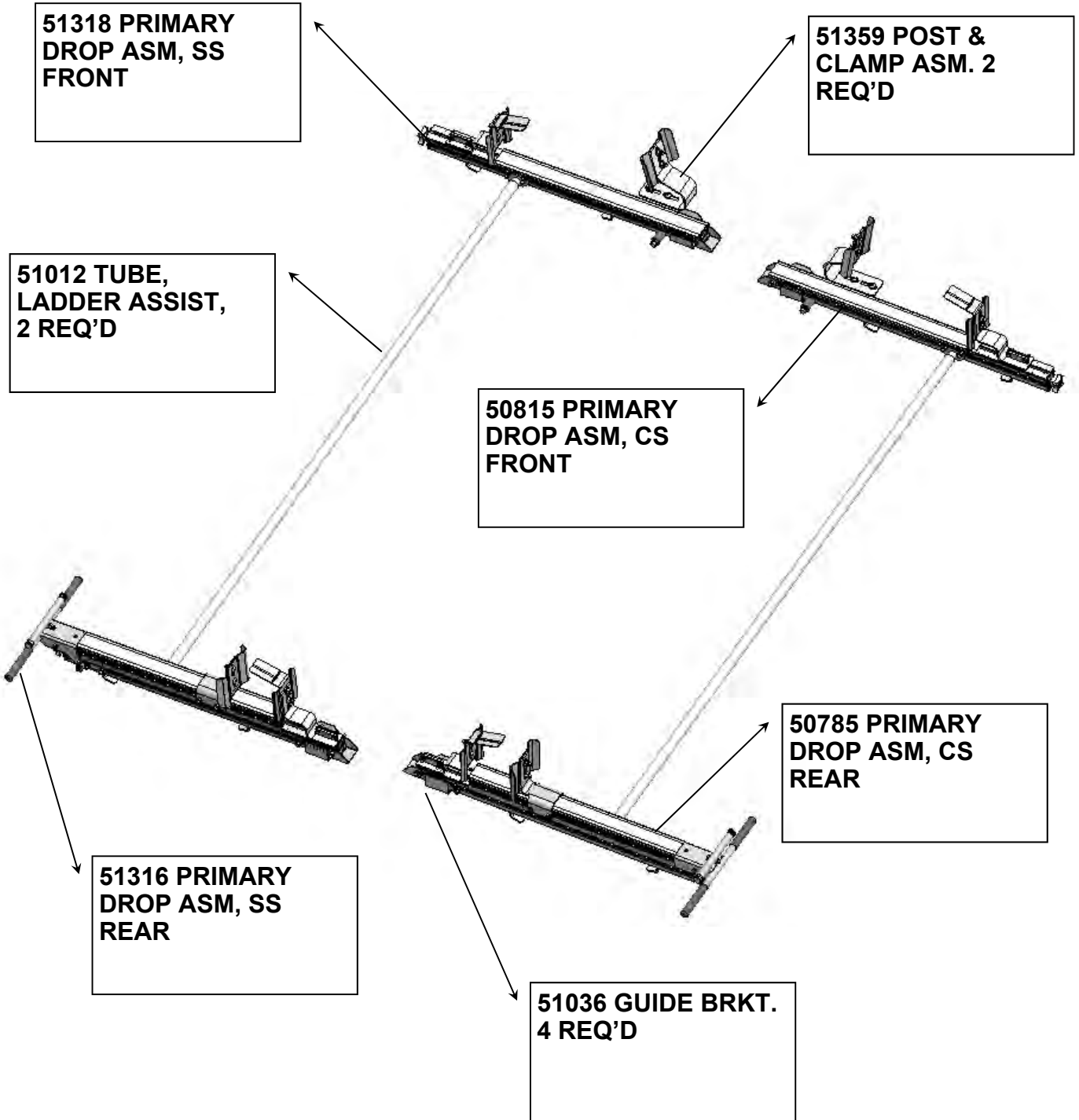

STEP 12 : ASSEMBLE BRACKETS TO THE FRONT CROSS BOW

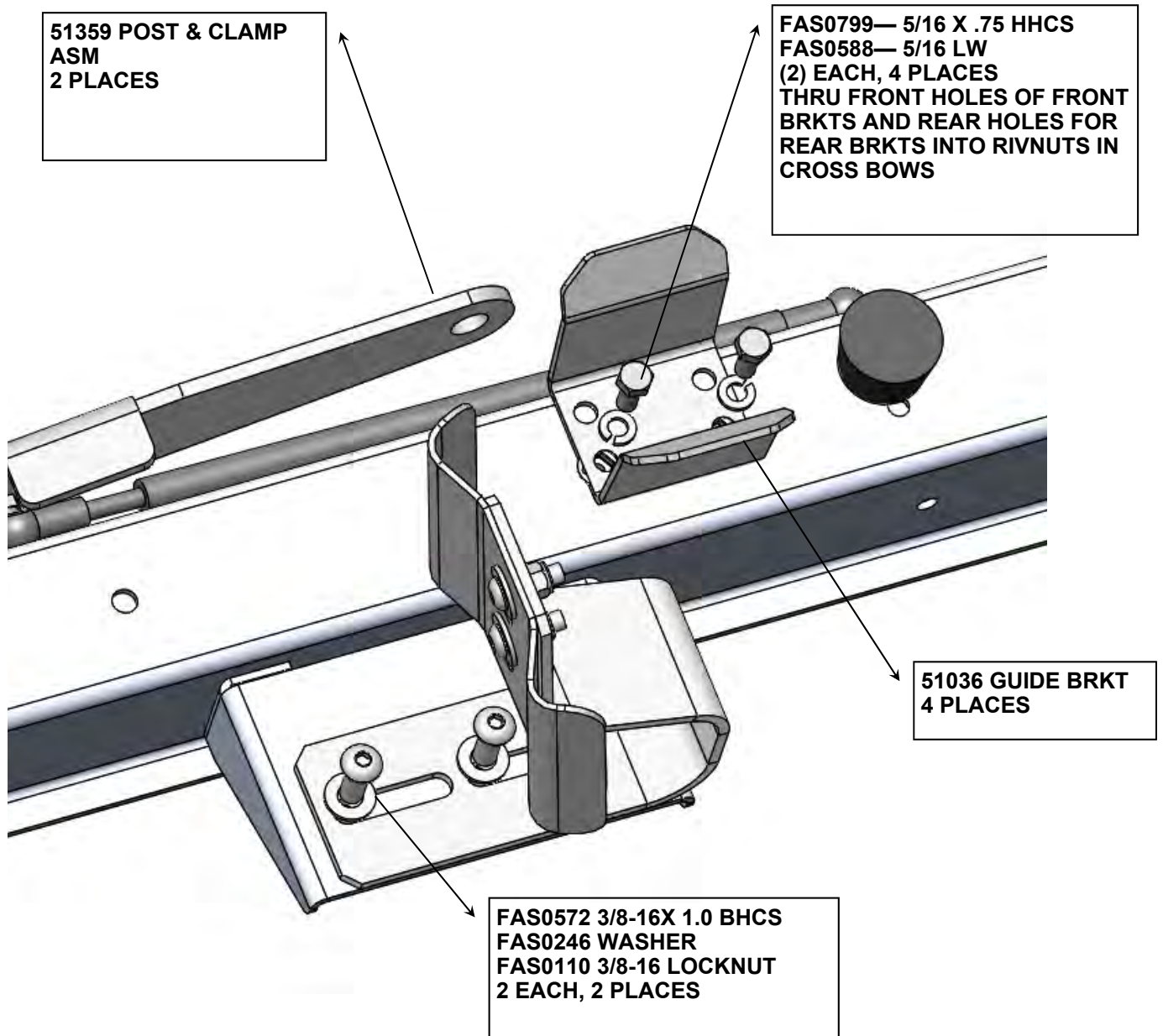

STEP 12 : COMPLETED VIEW OF THE FRONT CROSS BOW

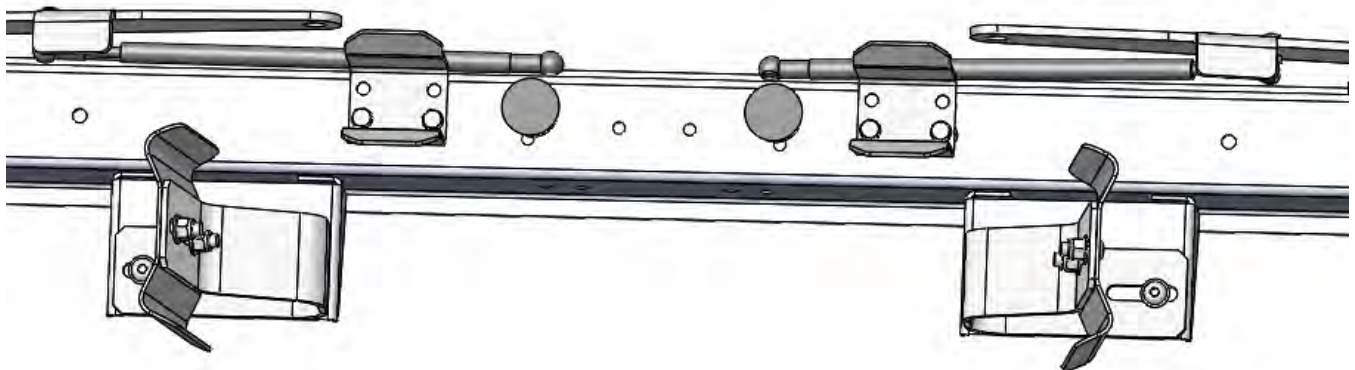

STEP 13 : ASSEMBLE REAR CURB SIDE PRIMARY DROP TO RACK

**SET 50785 PRIMARY DROP ASM, REAR CS IN PLACE ON REAR CROSS BOW.
USE GUIDE ROLLER**

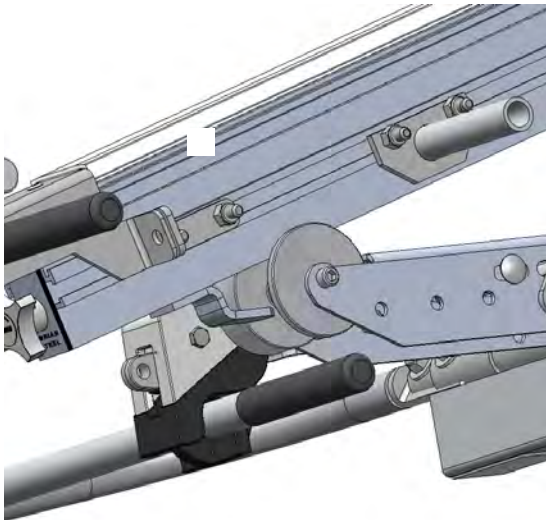

**50785 PRIMARY DROP
ASM CS REAR**

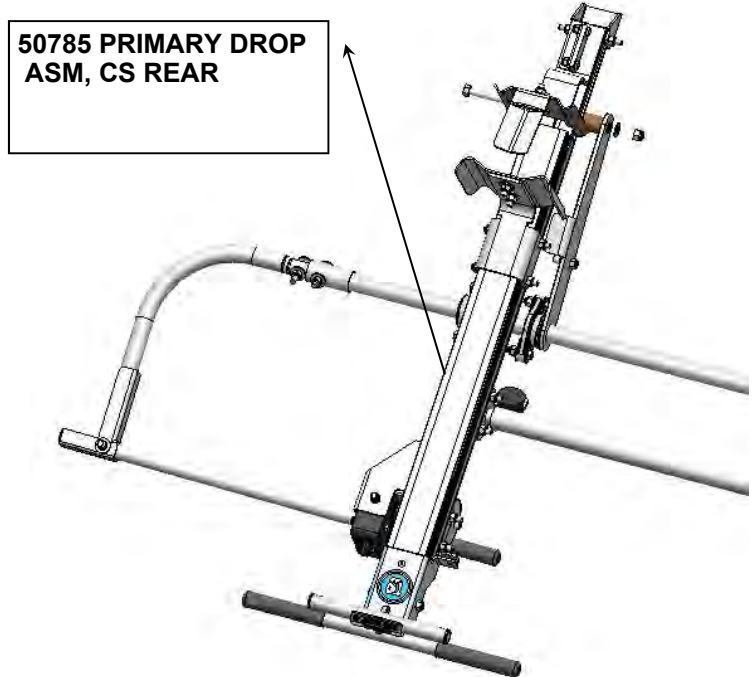

**50785 PRIMARY DROP
ASM, CS REAR**

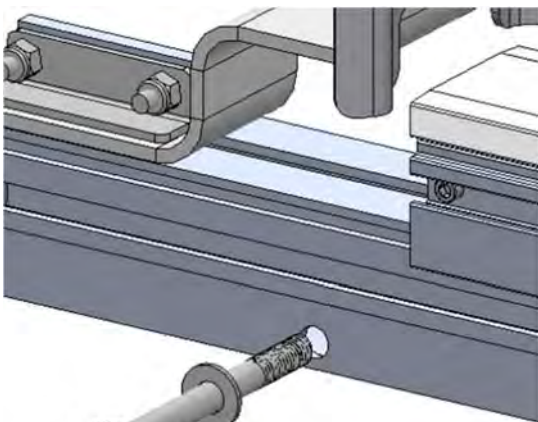

**FAS0286 3/8-16 X 4" HHCS
FAS0246 WASHER**

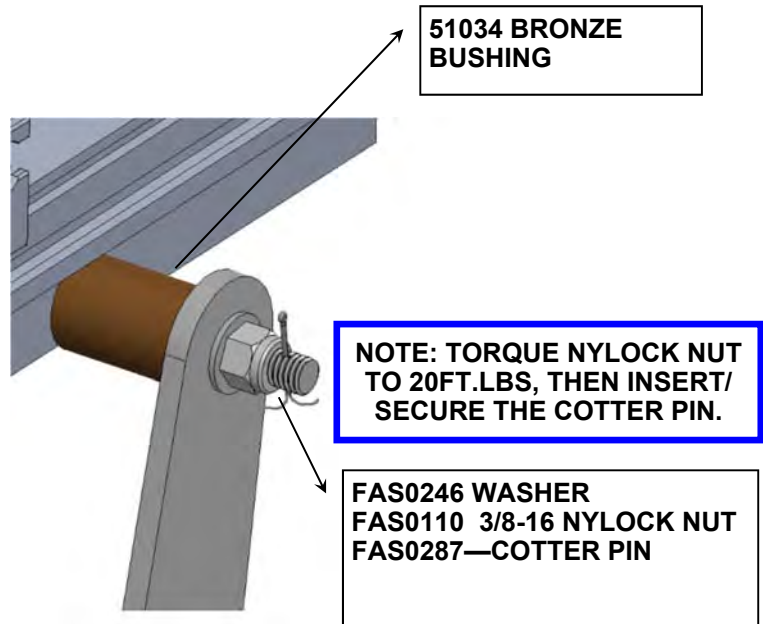

**51034 BRONZE
BUSHING**

**NOTE: TORQUE NYLOCK NUT
TO 20FT.LBS, THEN INSERT/
SECURE THE COTTER PIN.**

**FAS0246 WASHER
FAS0110 3/8-16 NYLOCK NUT
FAS0287—COTTER PIN**

**NOTE: AFTER THE COTTER
PIN IS INSERTED THROUGH
THE BOLT, SPREAD THE PIN
SO IT CAN NOT BE REMOVED.**

STEP 14 : ASSEMBLE FRONT SIDE PRIMARY DROP TO RACK

SET 50815 PRIMARY DROP ASM, FRONT CS IN PLACE ON FRONT CROSS BOW. USE GUIDE ROLLER AFTER LADDER ASSIST TUBE IS ON BOTH STUB SHAFTS

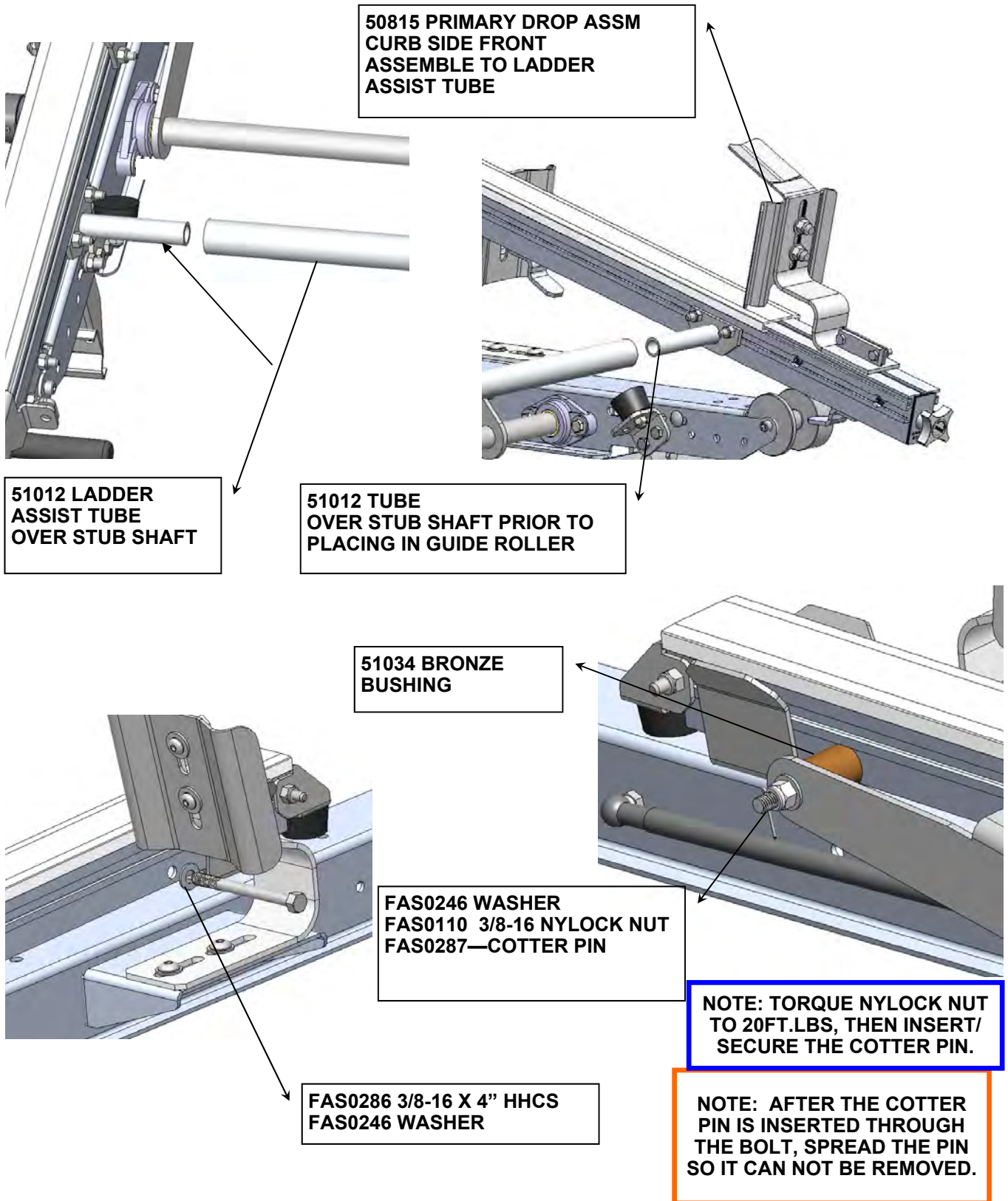



STEP #15 : FOR A DOUBLE DROP DOWN, INSTALL STREET SIDE USING STEPS #13 & 14 AS YOUR GUIDE.

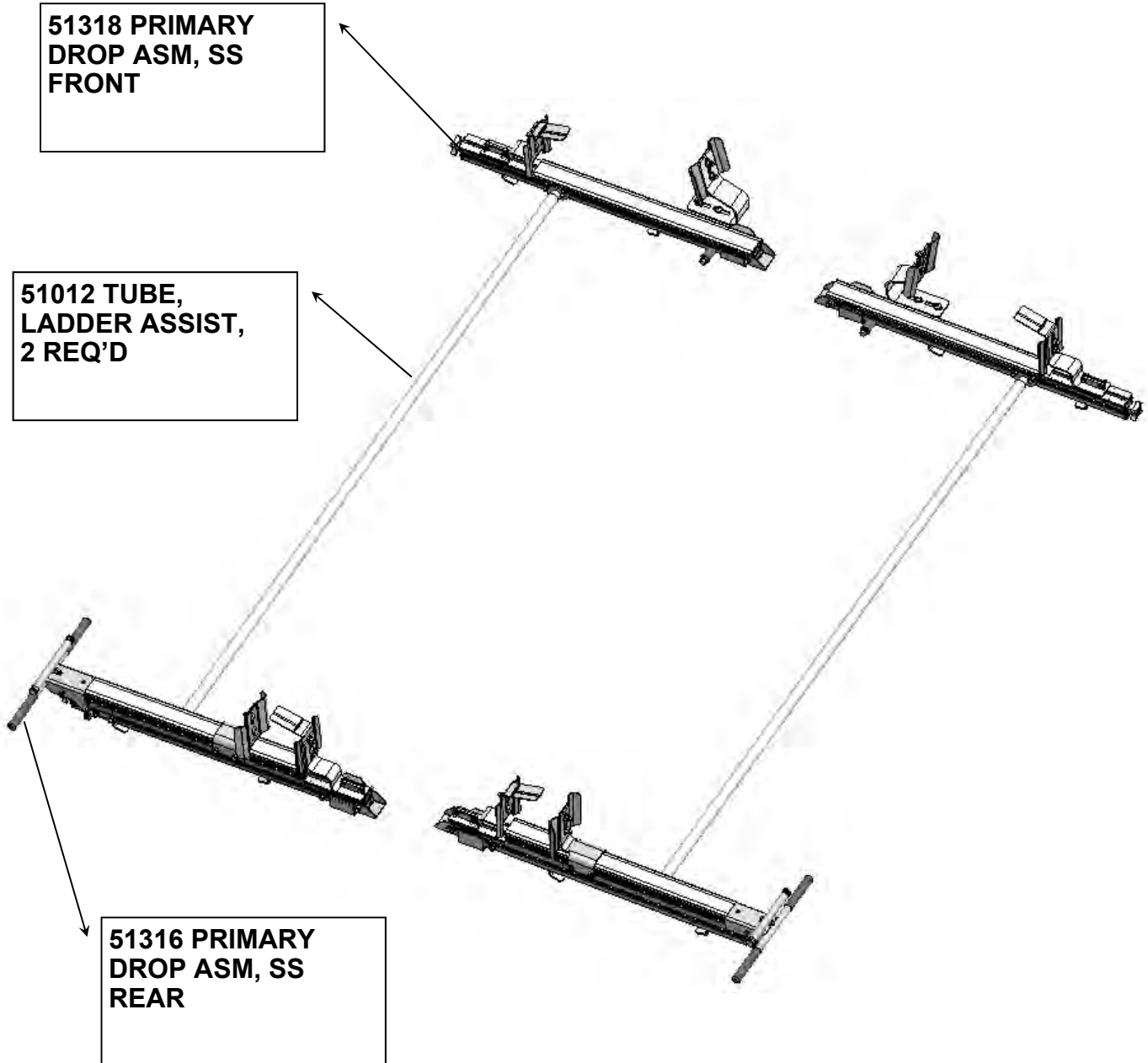

**DOUBLE CHECK ALL FASTENERS LOCATIONS TO BE SURE THAT ALL FASTENERS ARE TIGHTENED TO SPECIFICATIONS.
YOUR INSTALLATION IS NOW COMPLETE!
STOW THIS COPY IN THE VEHICLE FOR FUTURE REFERENCES!**



**STEP #16 : YOUR DOUBLE DROP DOWN INSTALLATION IS NOW COMPLETE
GO TO STEP 17 FOR A COMBO RACK**



**DOUBLE CHECK ALL FASTENERS LOCATIONS TO BE SURE THAT ALL
FASTENERS ARE TIGHTENED TO SPECIFICATIONS.
YOUR INSTALLATION IS NOW COMPLETE!
STOW THIS COPY IN THE VEHICLE FOR FUTURE REFERENCES!**



**STEP #17 : COMBO RACK, INSTALL STREET SIDE GRIP LOCK
ADD WEAR STRIPS**

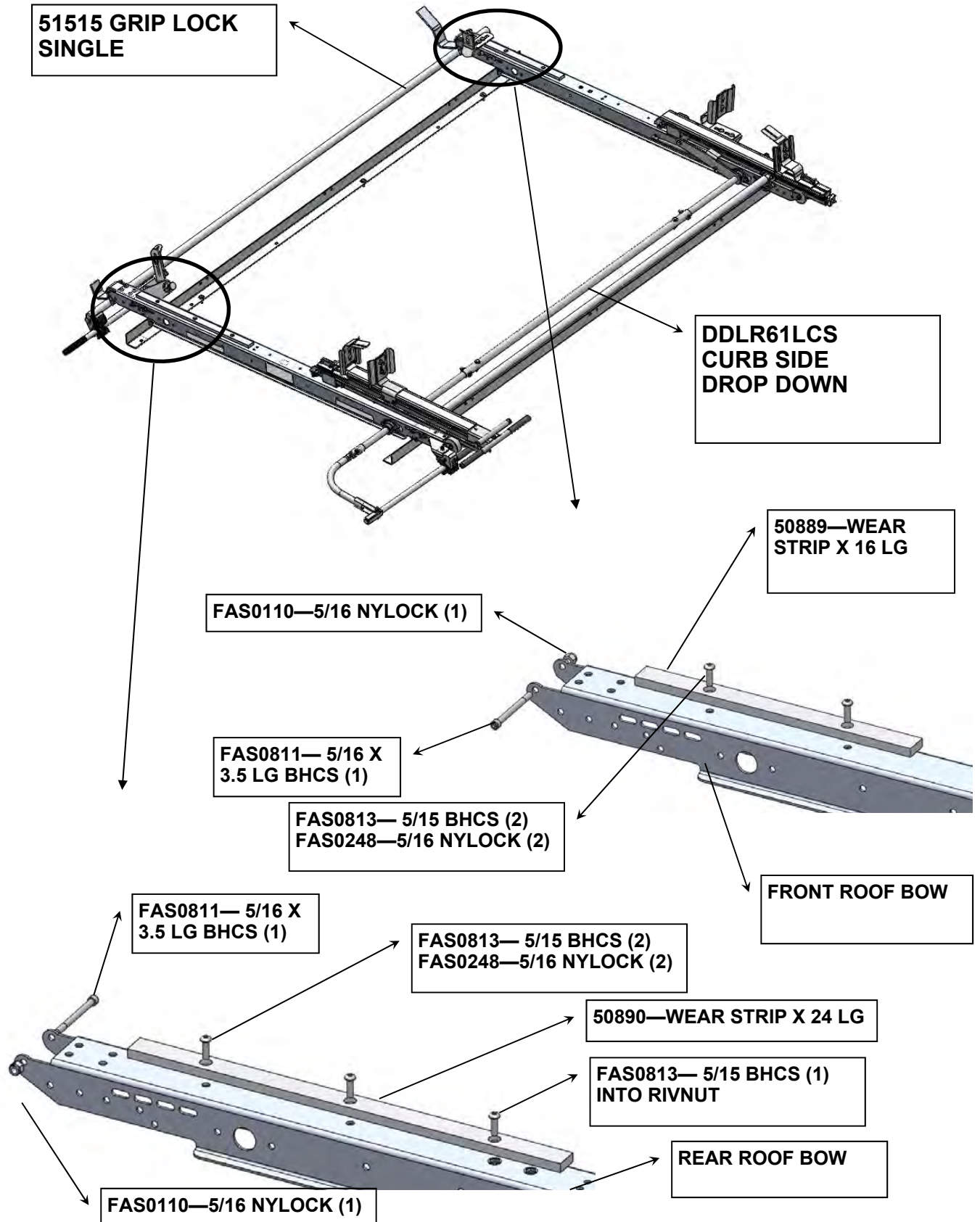

STEP #18 : COMBO RACK, INSTALL STREET SIDE GRIP LOCK

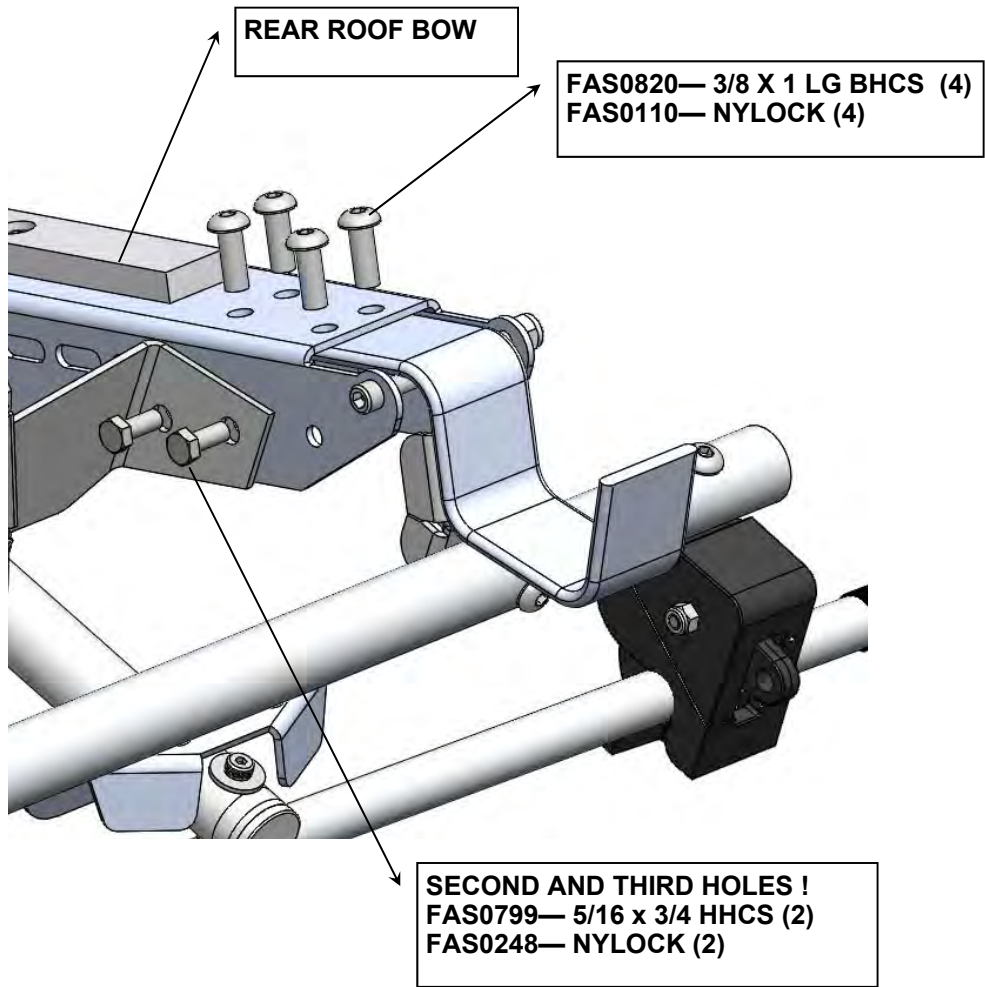
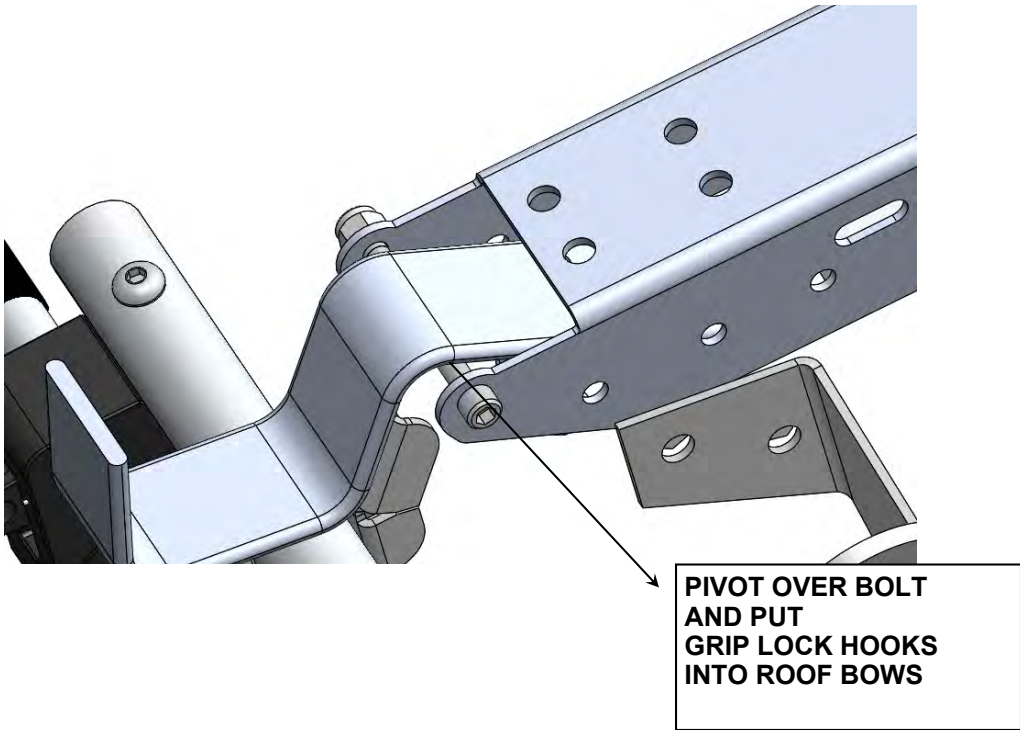



STEP #19: FRONT ROOF BOW ASSEMBLY –STREET SIDE

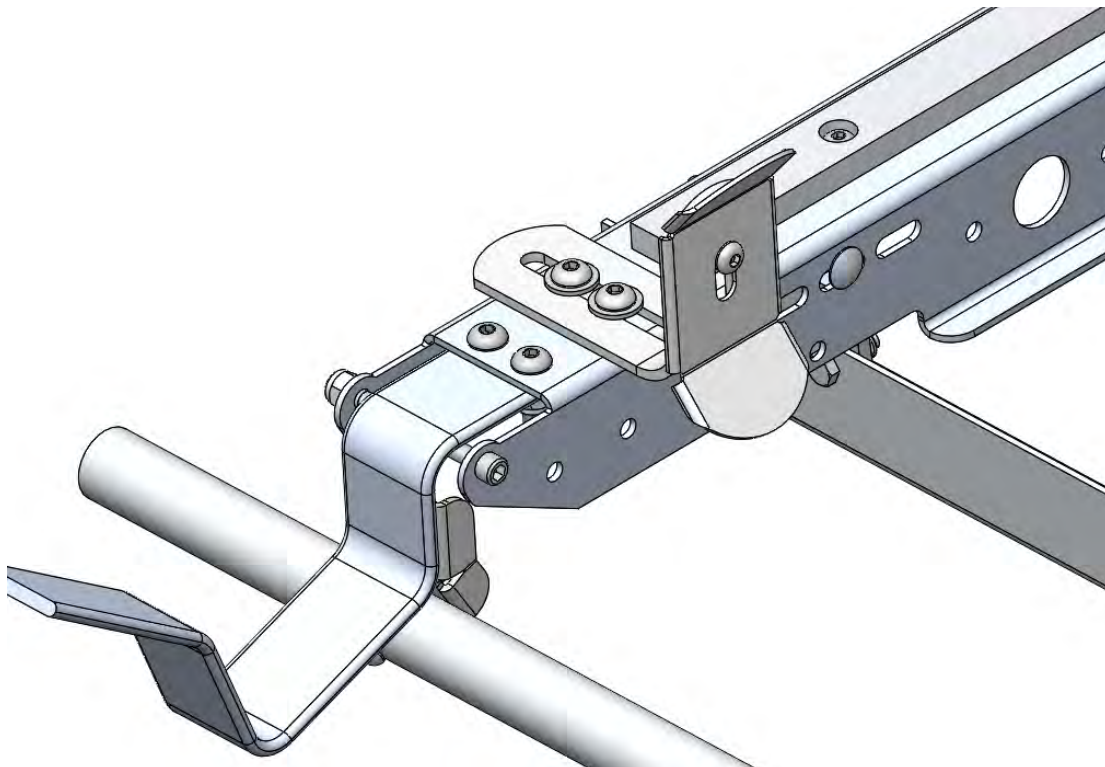
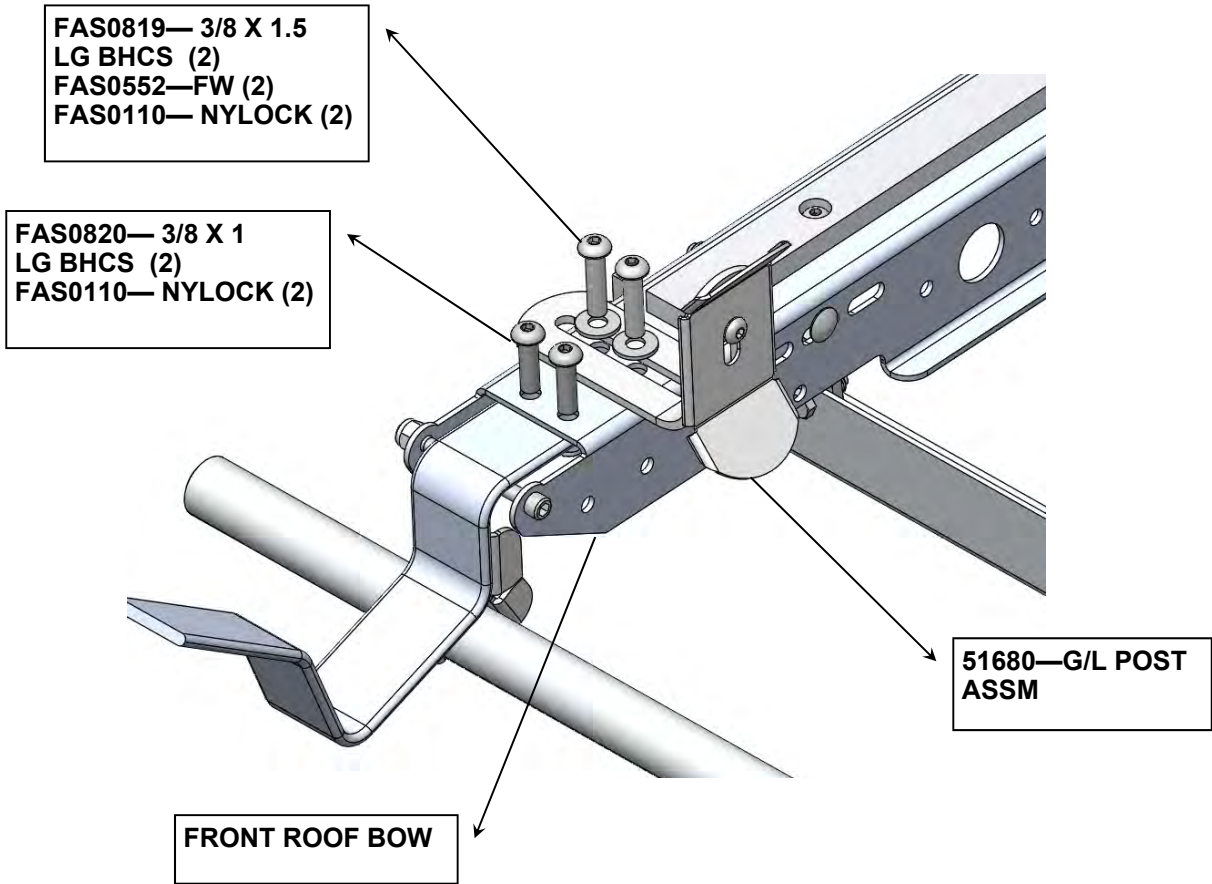

STEP #23 : YOUR DROP DOWN COMBO INSTALLATION IS NOW COMPLETE



**DOUBLE CHECK ALL FASTENERS LOCATIONS TO BE SURE THAT ALL
FASTENERS ARE TIGHTENED TO SPECIFICATIONS.
YOUR INSTALLATION IS NOW COMPLETE!
STOW THIS COPY IN THE VEHICLE FOR FUTURE REFERENCES!**



**REAR CLAMP PAD MOVES TOWARDS CURB TO
TIGHTEN LADDER TO RACK**

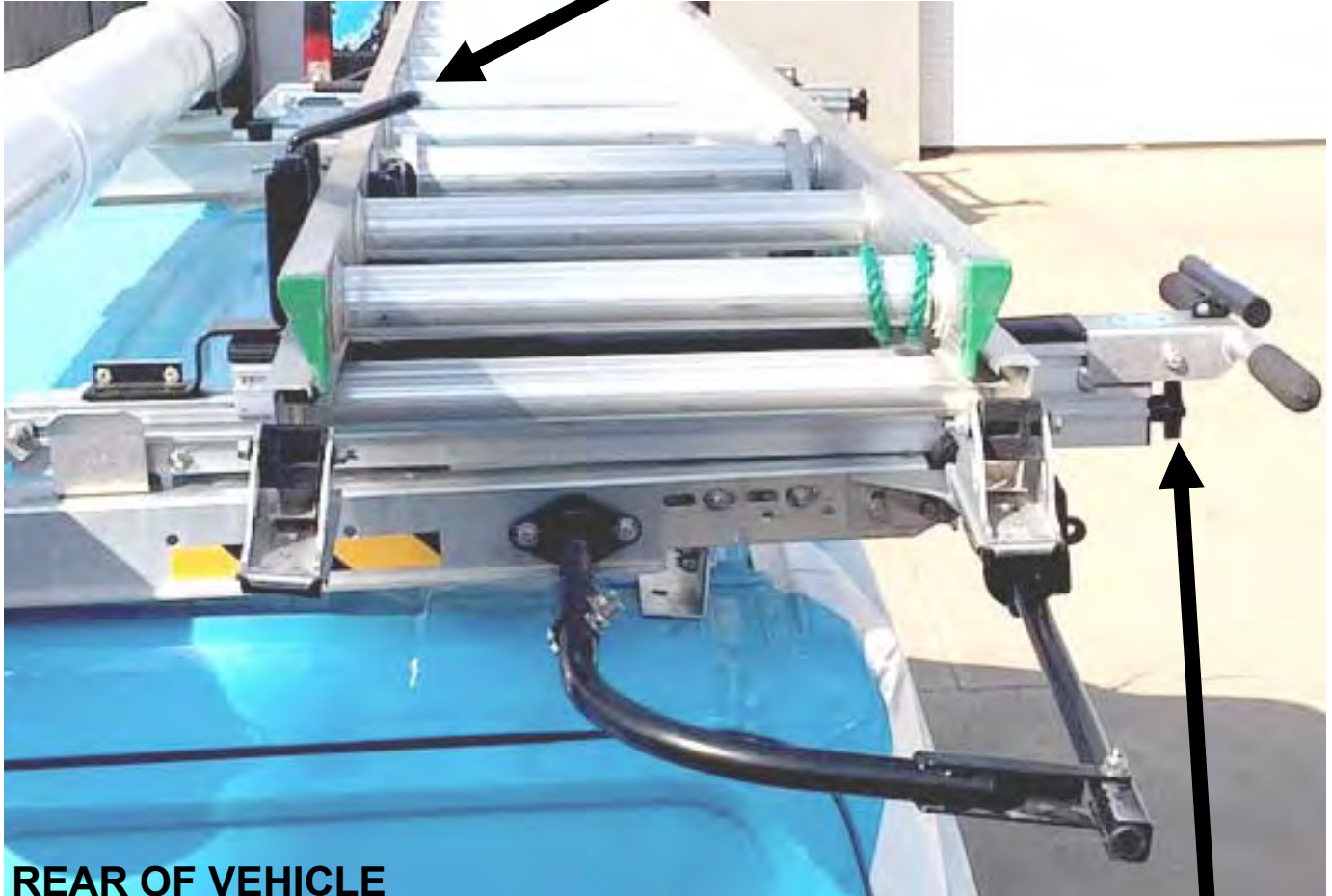

REAR OF VEHICLE

**TURN KNOB TO ADJUST TO
YOUR LADDER.**

**DO NOT OVER TIGHTEN!
CLAMP PAD SHOULD JUST
TOUCH THE LADDER.**



Proper Clamp Pad Locations

Below is the proper way to clamp the ladder to the vehicle (highlighted in green)

How to inspect for this: Properly placed clamp pads should be in close proximity to each other to allow the clamp pads to securely retain the ladder from side to side motion and front to back motion.

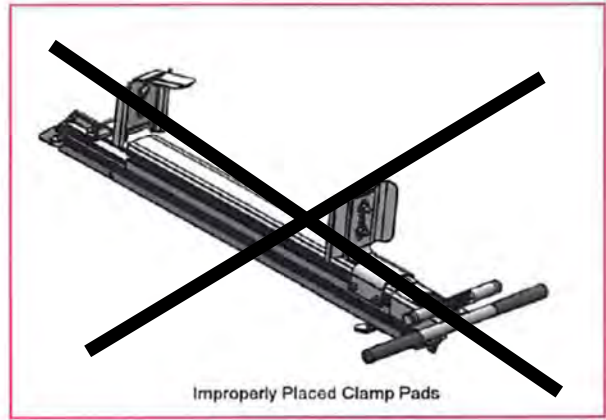
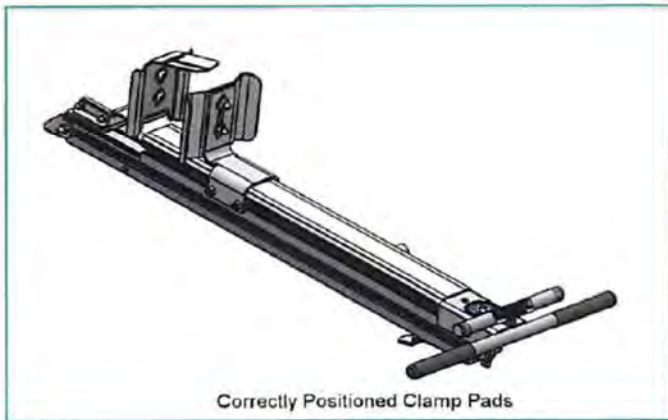

Above is the wrong way to clamp the ladder to the vehicle

**FRONT CLAMP PAD MOVES TOWARDS STREET
TO TIGHTEN LADDER TO RACK**



FRONT OF VEHICLE

**TURN KNOB TO ADJUST TO
YOUR LADDER.**

**DO NOT OVER TIGHTEN!
CLAMP PAD SHOULD JUST
TOUCH THE LADDER.**



DDL61 Series Final Adjustment Instruction (GMFSV / Ford Transit)

**DOUBLE CHECK ALL FASTENERS LOCATIONS TO BE SURE THAT ALL FASTENERS ARE
TIGHTENED TO SPECIFICATIONS.**

YOUR INSTALLATION IS NOW COMPLETE!

STOW THIS COPY IN THE VEHICLE FOR FUTURE REFERENCES!



PRODUCT WEIGHT

31 lbs

WIDTH x DEPTH x HEIGHT

CAPACITY

190

COLOR

Aluminum

CATALOG NUMBER

RRKFT130

PRODUCT FEATURES

This Roof Cross-bow Kit is designed to fit the Ford Transit, 130 and 148 wheel base. This base kit allows mounting of the new re-designed drop down and grip-lock ladder rack series.

Cross-bow kits is secured to the Ford Transit by OEM supplied fastening points.

SEE PAGE 2 FOR APPLICATION NOTES AND ACCESSORIES, OTHER PRODUCTS THAT WORK WITH THIS UNIT.

CATALOG NUMBER RRKFT130

PRODUCT APPLICATION

This Roof Cross-bow Kit is designed to fit the Low roof transit, 130 and 148 wheel base. This will allow mounting of the new re-designed drop down and grip-lock ladder rack series.

ACCESSORIES THAT WILL WORK WITH THIS PRODUCT

<i>CATALOG NUMBER</i>	<i>DESCRIPTION</i>
DDL61FTL	DROP DOWN LADDER RACK, CURB SIDE
DDL63FTL	DROP DOWN LADDER RACK, DOUBLE
61-GLFTL	GRIP LOCK, SINGLE, CURB SIDE
63-GLFTL	GRIP LOCK, DOUBLE

SPECIAL APPLICATION NOTES

Introduction / Comments:

THIS ROOF RAIL AND CROSS BOW KIT IS DESIGNED FOR THE FORD TRANSIT LOW ROOF VANS, BOTH 130" AND 148" WHEEL BASE. IT IS THE BASE UNIT FOR ALL OF THE LADDER RACK COMBINATIONS FOR THIS VEHICLE. INCLUDING THE SINGLE AND DOUBLE DROP DOWN LADDER RACK, THE SINGLE AND DOUBLE GRIP LOCK, AND THE COMBO GRIP LOCK DROP DOWN LADDER RACK.

Note:

It is advised that all fasteners used in this assembly and installation of this Rack should be checked for tightness at the following intervals: @ 2-weeks and again @ 6-weeks of operation. This preventive maintenance step must be completed to ensure your package gives you long service life.



TO VIEW INSTALL VIDEO



**RRKFT130
ROOF RAIL AND CROSS BOW KIT
FORD TRANSIT LOW ROOF VANS**

- PRECAUTIONS -



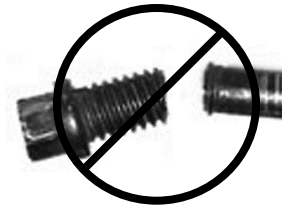

 **CAUTION** 
**THE USE OF AIR IMPACT TOOLS CAN
OVER-TORQUE FASTENERS AND
CAUSE FASTENER FAILURE!**



 **CAUTION** 
**ALL INSTALLATION HOLES SHOULD BE SEALED
WITH SILICON OR BUTYL SEALANT TO PREVENT
EXHAUST FUMES FROM ENTERING THE VEHICLE!**



 **DANGER** 
**INSPECT FOR FUEL TANK, FUEL LINES, BRAKE LINES, HIGH
VOLTAGE BATTERIES AND ELECTRICAL LINES PRIOR TO
DRILLING TO AVOID DAMAGING CRITICAL VEHICLE SYSTEMS
OR INJURY TO INSTALLER DURING INSTALLATION PROCESS!**



 **CAUTION** 
**TO AVOID DAMAGING THE VEHICLE ALWAYS
USE DRILL STOPS WHEN DRILLING ANY IN-
STALLATION HOLES!**



- IMPORTANT WARRANTY REQUIREMENTS -

1. SUBSTITUTING ADRIAN STEEL SPECIFIED FASTENERS FOR ASSEMBLY AND/OR INSTALLATION WILL VOID YOUR PRODUCT WARRANTY.
2. ALL HOLES DRILLED INTO VEHICLE SHOULD HAVE THE RAW METAL EDGES SEALED WITH A SELF-ETCHING PRIMER TO RESIST CORROSION AND POTENTIAL FASTENER POINT FAILURE.
3. ALL FASTENERS USED IN THE INSTALLATION OF THIS PRODUCT SHOULD BE TIGHTENED TO THE TORQUE(S) SPECIFIED IN THESE INSTRUCTIONS.
4. THESE INSTRUCTIONS SHOULD BE KEPT WITH THE VEHICLE.

THE BASIC TOOLS NEEDED FOR MOST INSTALLATIONS



DRILL



DRILL BIT WITH
STOP

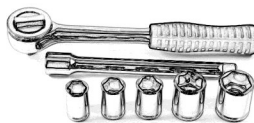

RATCHET, SOCKETS
AND/OR WRENCHES



SCREWDRIVERS



MEASURING TAPE

ADDITIONAL TOOLS MAY BE NEEDED FOR THIS INSTALLATION AND THEY WILL BE IDENTIFIED IN THE STEPS THAT FOLLOW.

BAG50896 - FASTENER BAG

ITEM NO.	PART NUMBER	DESCRIPTION	BAG50896/QTY.
1	BAG0406-A	4" x 6" 3MIL AUTOBAG	1
2	FAS0552	Washer, Flat, 5/16, SST	16
3	FAS0597	Screw, Hex Hd, 5/16-18x 1.00 SST	8
4	FAS0248	Nut, Nylon Insert Lock, 5/16-18 SST	16
5	FAS0808	Bolt, Carriage, 5/16-18x3 1/2	8

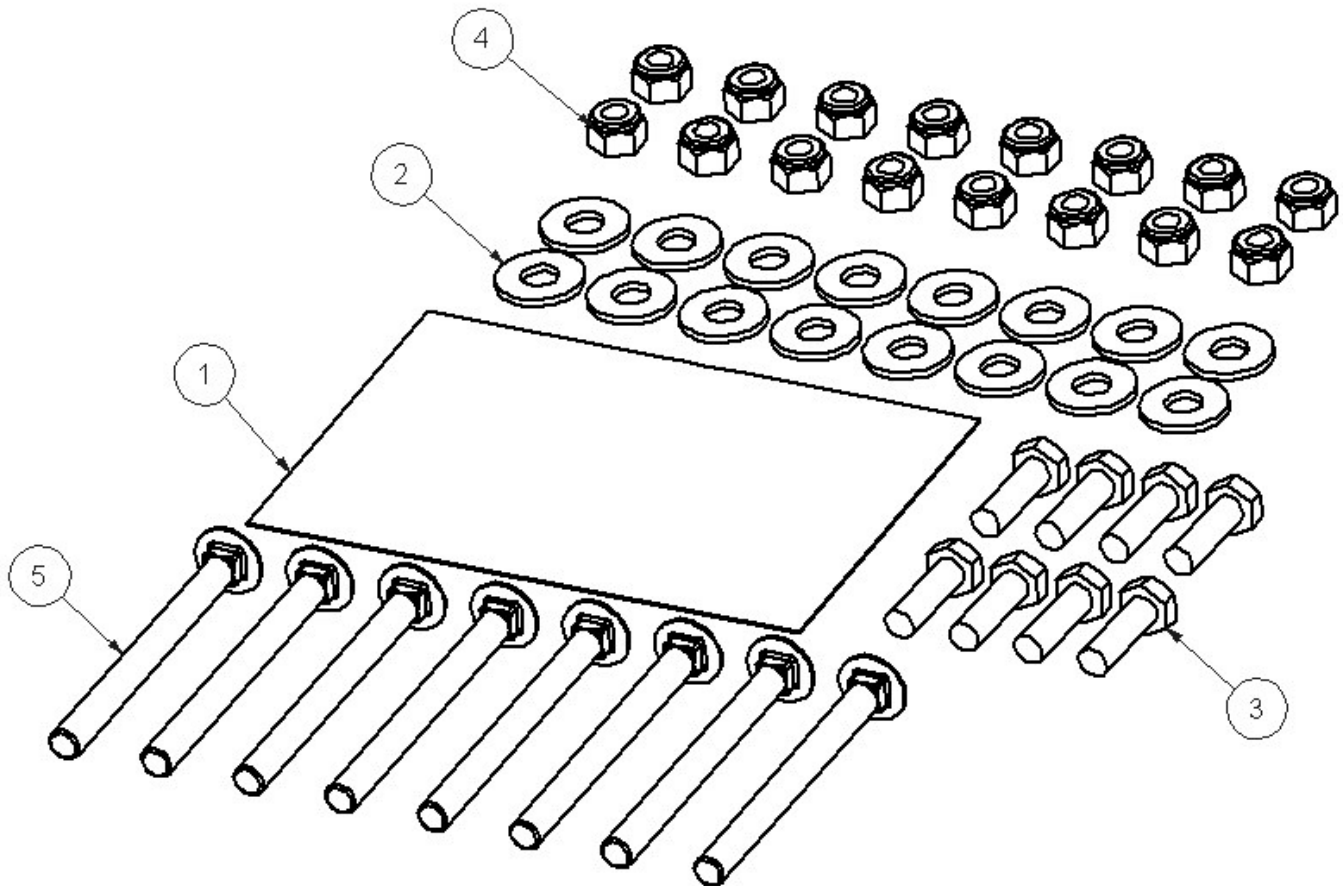

BAGRRKFTL—FASTENER BAG, TRANSIT ROOF RAILS

ITEM NO.	PART NUMBER	DESCRIPTION	BAGFTLRRK/QTY.
1	BAG0406-A	4" x 6" 3MIL AUTOBAG	1
2	FAS0552	Washer, Flat, 5/16, SST	8
3	FAS0588	Washer, Lock, Split, 5/16, SS	8
4	05586-0	Butyl Tape, T224 -1/2"X 1' Roll	1
5	26618-0	Silicone Sealant	1
6	FAS0173	SCREW, HH, M8-1.25X35 SS	8

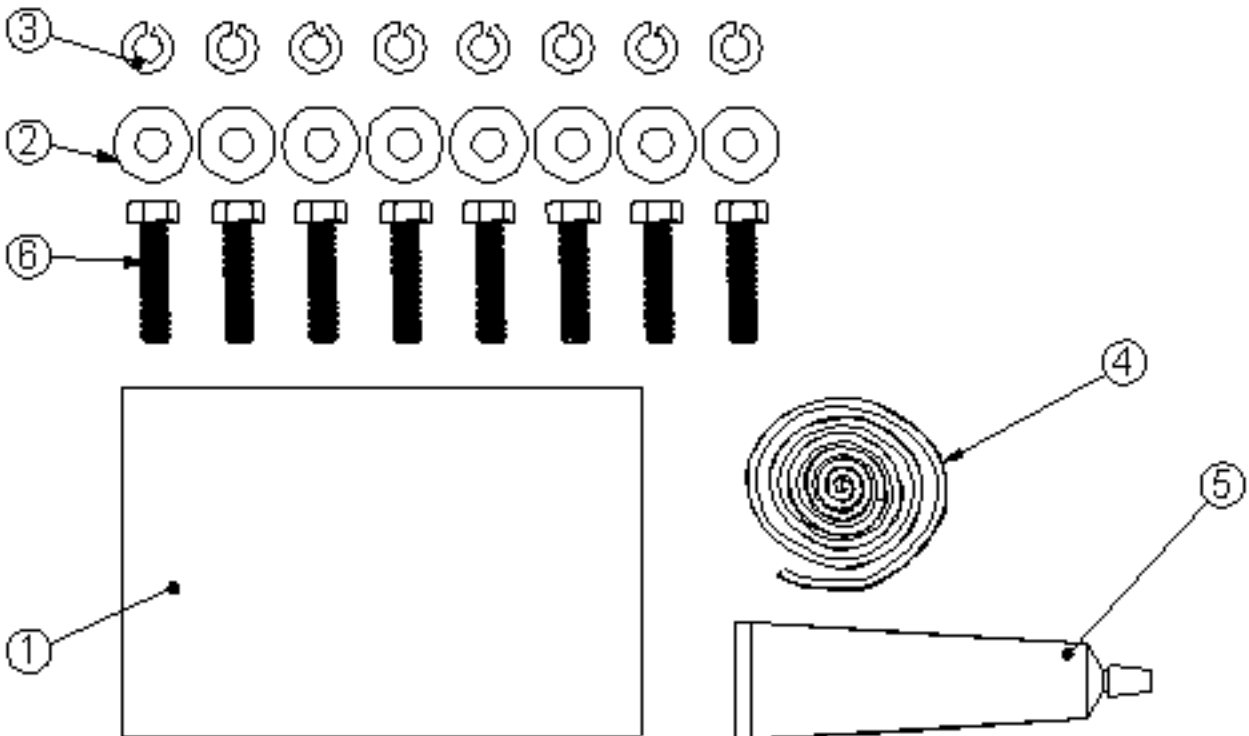

LADDER RACK ASSEMBLY—DDL63FTL

ITEM NO.	PART NUMBER	DESCRIPTION	DDL63FTL QTY.
1	RRKFT130	ROOF RAIL KIT, TRANSIT, LR	1
2	DDL61LCS	DDL61, CURB SIDE, LOW ROOF	1
3	DDL61LSS	DDL61, STREET SIDE, LOW ROOF	1

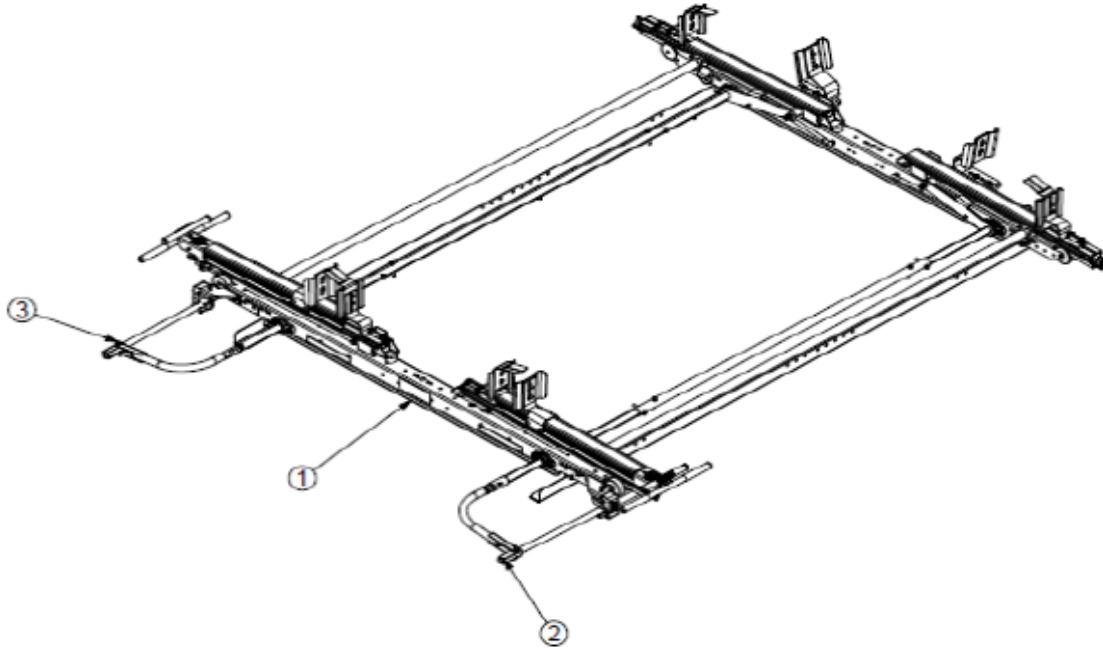

RRKFT130 - ROOF RAIL KIT, TRANSIT, LR

ITEM NO.	PART NUMBER	DESCRIPTION	RRKFT130 QTY.
1	50893	ROOF RAIL, SS FTL	1
2	50894	Roof Rail, CS, FTL	1
3	51398	FRONT CROSS BOW ASSM, TRANSIT STD	1
4	51399	REAR CROSS BOW ASSM, TRANSIT STD	1
5	40323	FOOT, NISSAN	4

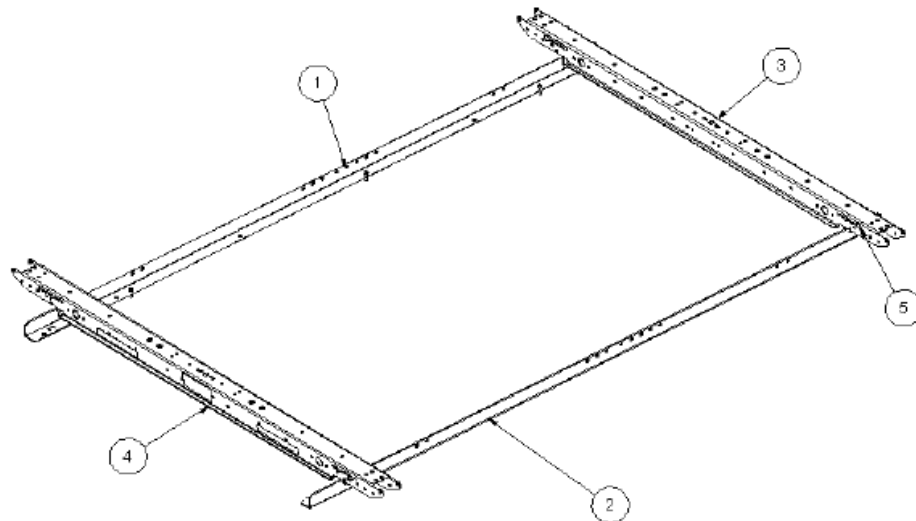

LADDER RACK ASSEMBLY — 63 - GLFTL

ITEM NO.	PART NUMBER	DESCRIPTION	63-GLFTL/QTY.
1	RRKFT130	ROOF RAIL KIT, TRANSIT, LR	1
2	51686	GRIP LOCK LADDER RACK, DBL, LR	1

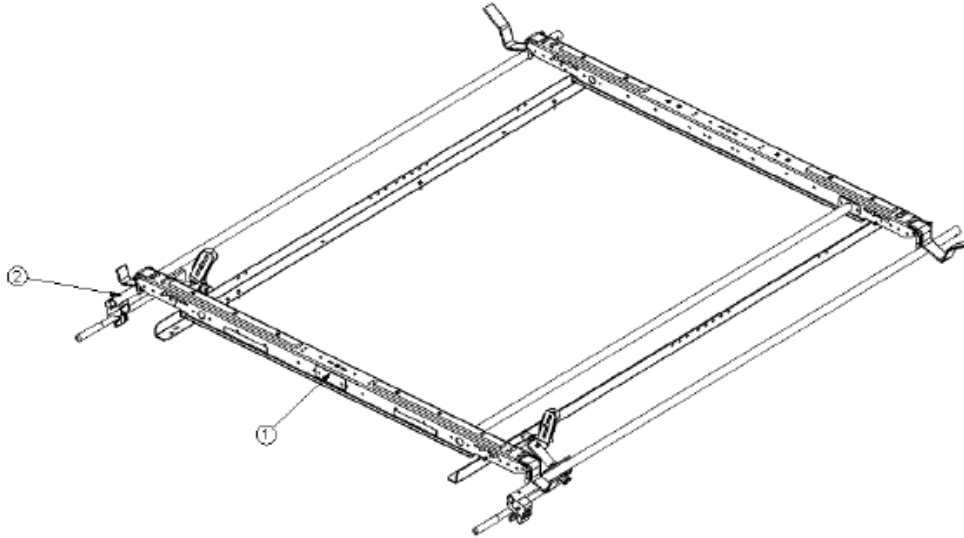

RRKFT130 — ROOF RAIL KIT, TRANSIT, LR

ITEM NO.	PART NUMBER	DESCRIPTION	RRKFT130/QTY.
1	50893	ROOF RAIL, SS FTL	1
2	50894	Roof Rail, CS, FTL	1
3	51398	FRONT CROSS BOW ASSM, TRANSIT STD	1
4	51399	REAR CROSS BOW ASSM, TRANSIT STD	1
5	40323	FOOT,NISSAN	4

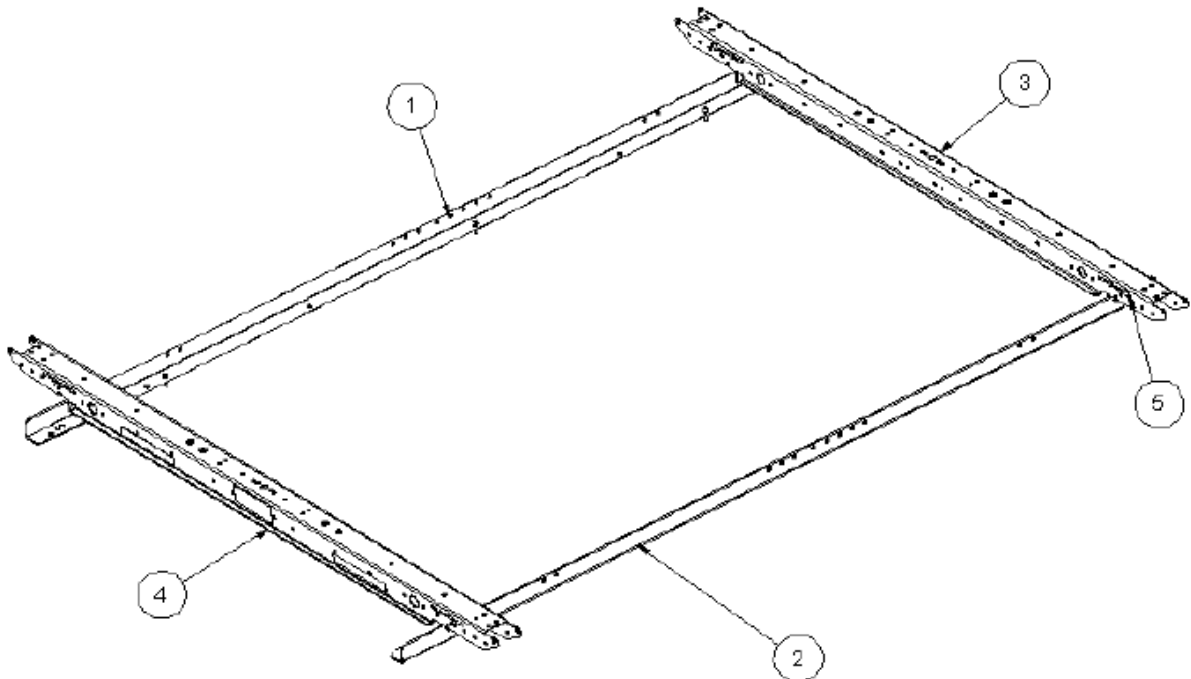

STEP #1 : PREP ROOF RAILS—NOTE THE HOLE PATTERNS

50893 STREET SIDE ROOF RAIL
TOE UP TO THE OUTSIDE

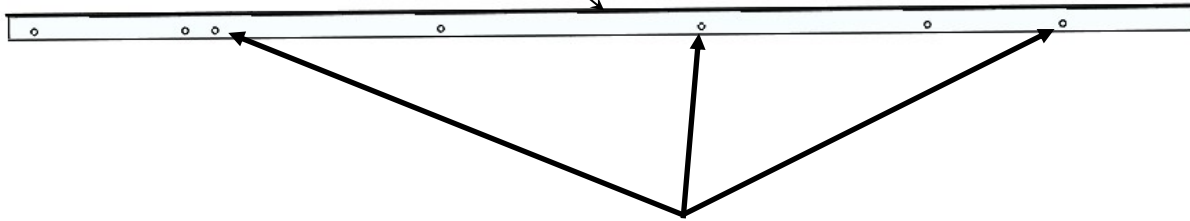

130" WB MOUNTING
LOCATIONS BOTH SIDES
3rd, 5th and 7th HOLE

REAR OF THE VAN

148" WB MOUNTING
LOCATIONS BOTH SIDES
2nd, 4th and 6th HOLE

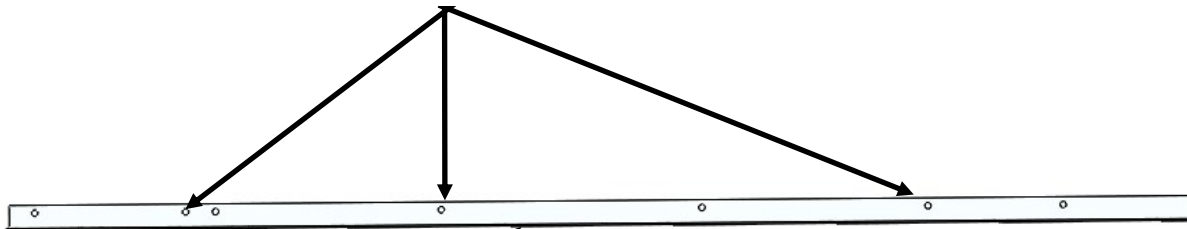

50894 CURB SIDE ROOF RAIL
TOE UP TO THE OUTSIDE

50893 STREET SIDE ROOF RAIL
TOE UP TO THE OUTSIDE

REAR OF VAN

43417 DOUBLE
SIDED TAPE

3.5

47117 FOAM STRIP CUT TO 91.5" AND
ATTACH TO THE BOTTOM OF THE
RAIL, LEAVING 3.5" AT THE REAR FOR
THE DOUBLE SIDED TAPE

52709, PLACE THE 1/4 THICK RUBBER
SPACER UNDER EACH HOLE TO BE
USED AS SHOWN.

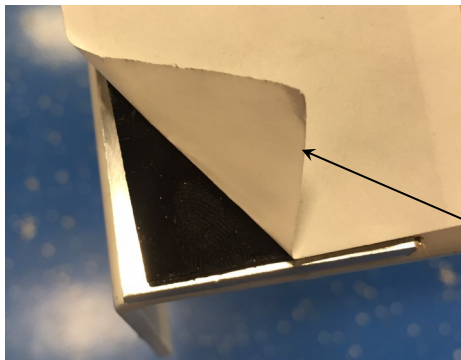

43417 DOUBLE SIDED TAPE
PEAL EDGE OVER TO ASSIST
WHEN INSTALLING

SHIP THRU ONLY—STEP #2A INSTALL RAILS ON VEHICLE

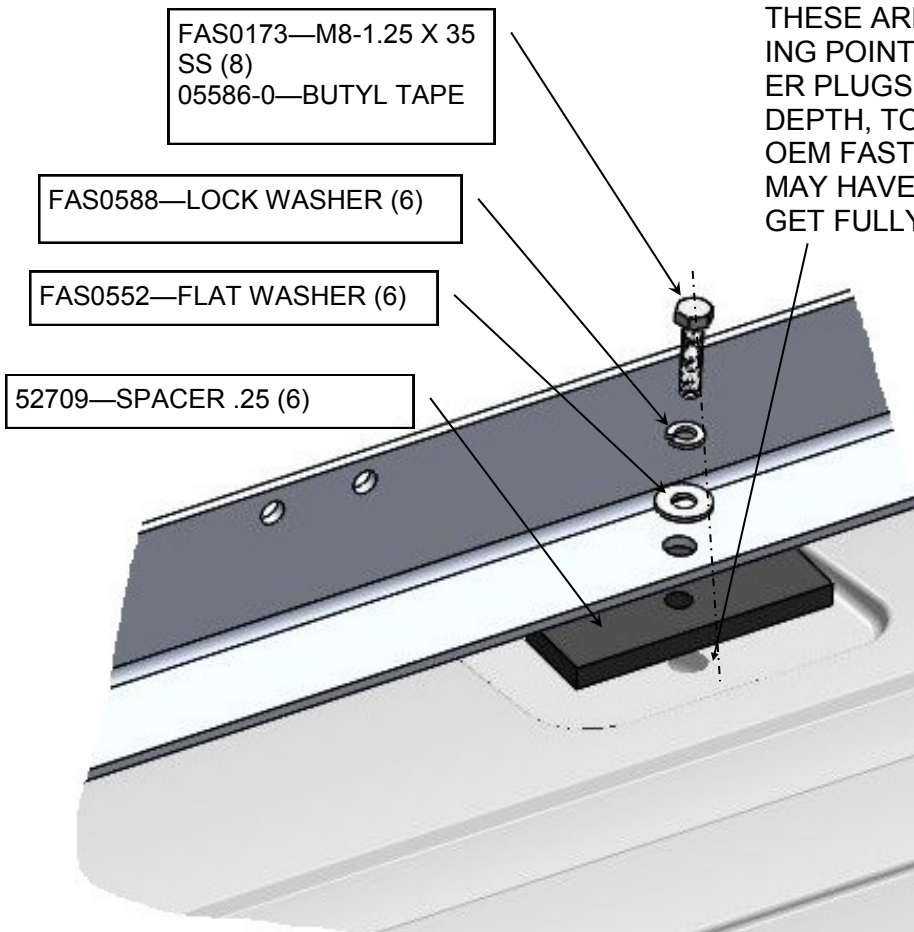

REMOVE PLASTIC PLUGS FROM SQUARE DEPRESSIONS ONLY. THESE ARE THE FACTORY MOUNTING POINTS. DO **NOT** REMOVE OTHER PLUGS!! RUN M8-1.25 TAP, FULL DEPTH, TO CLEAN OUT THREADS IN OEM FASTENER IF NECESSARY. MAY HAVE TO REPEAT PROCESS TO GET FULLY CLEAN.

CAREFULLY REMOVE PLASTIC PLUGS FROM FACTORY ATTACHMENT POINTS. NOTE, THEY ARE INSTALLED PRIOR TO VEHICAL BEING PAINTED. IF ROOF CLEARANCE HOLES AND OEM FASTENER ARE MISALIGNED TOO FAR, HOLE IN ROOF SKIN MAY NEED TO BE ENLARGED (AND PRIMERED), AS WELL AS CORRESPONDING HOLE IN ROOF RAIL OF RACK. WRAP SCREWS WITH BUTYL TAPE BENEATH WASHERS, ENOUGH TO FILL HOLE IN RAIL. PUSH SREWS THRU FOAM, AND RUBBER PAD, ADD ENOUGH SILICONE TO FILL EACH CAVITY. INSTALL SCREWS AND WASHERS AS SHOWN. TORQUE TO 10 TO 12 FT LBS. TORQUE ALL FASTENERS ON RACK ITSELF TO 10-12 FT LBS. DO NOT OVER-TORQUE AS THESE ARE STAINLESS STEEL FASTENERS!

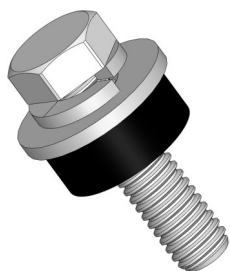

GENERIC PICTURE—MAY NOT LOOK LIKE YOUR FASTENER. MOUNTING SCREW WITH WASHERS AND BUTYL TAPE BEFORE INSTALLATION (LEFT) AND WHAT IT SHOULD LOOK LIKE AFTER INSTALLATION (RIGHT).



SHIP THRU ONLY—STEP #2B THIS IS WHAT YOUR SHIP THRU FINAL INSTALLATION WILL LOOKS LIKE.

CONTINUE TO STEP #3 FOR A COMPLETE ASSEMBLY / INSTALL

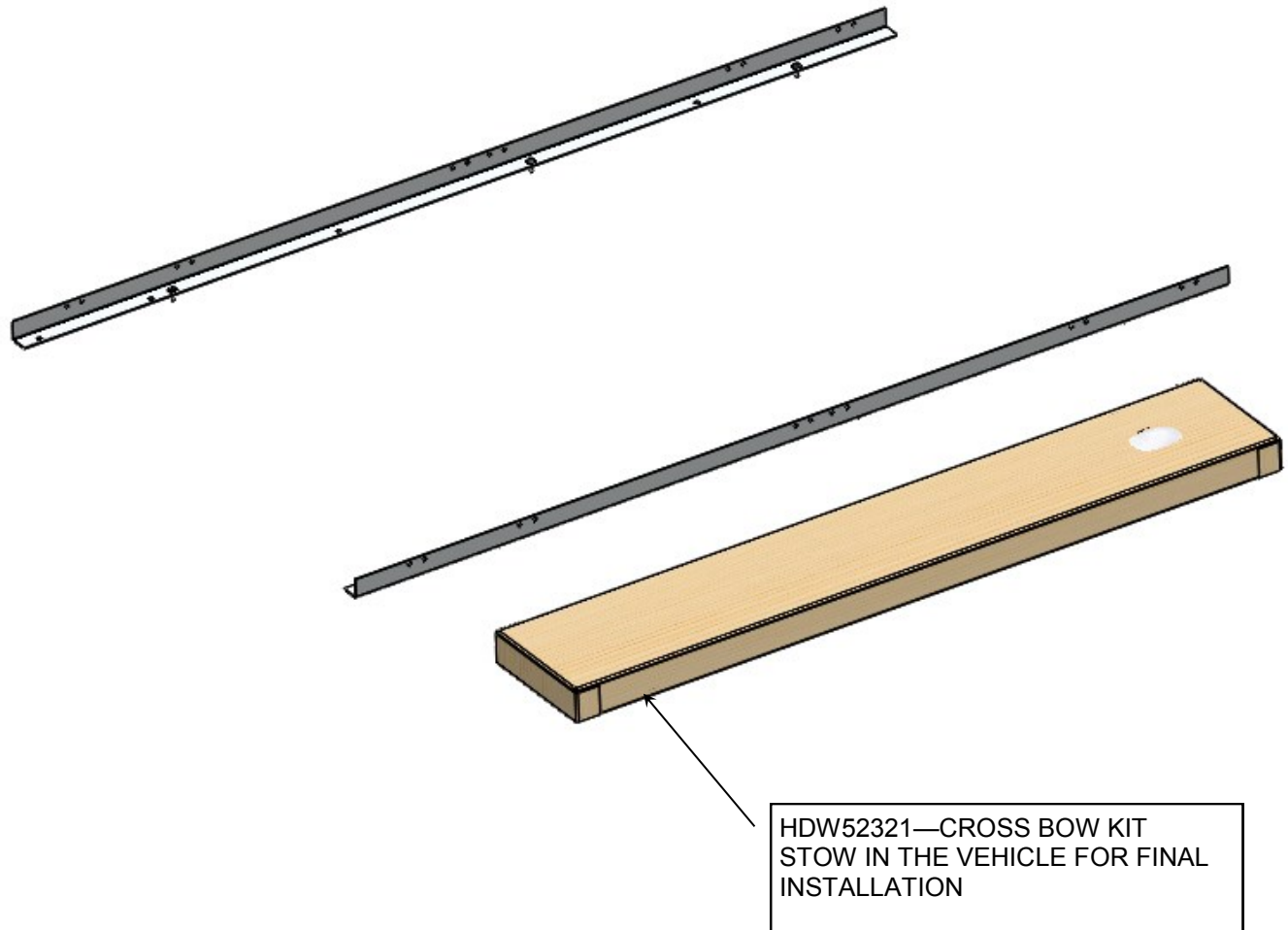

STEP #2B : THIS IS THE FINISHED ROOF RAIL KIT FOR SHIP THRU

-CONTINUE TO STEP #3 FOR A COMPLETE ASSEMBLY / INSTALL

STEP #3 : ASSEMBLE REAR CROSS BOW TO THE ROOF RAILS

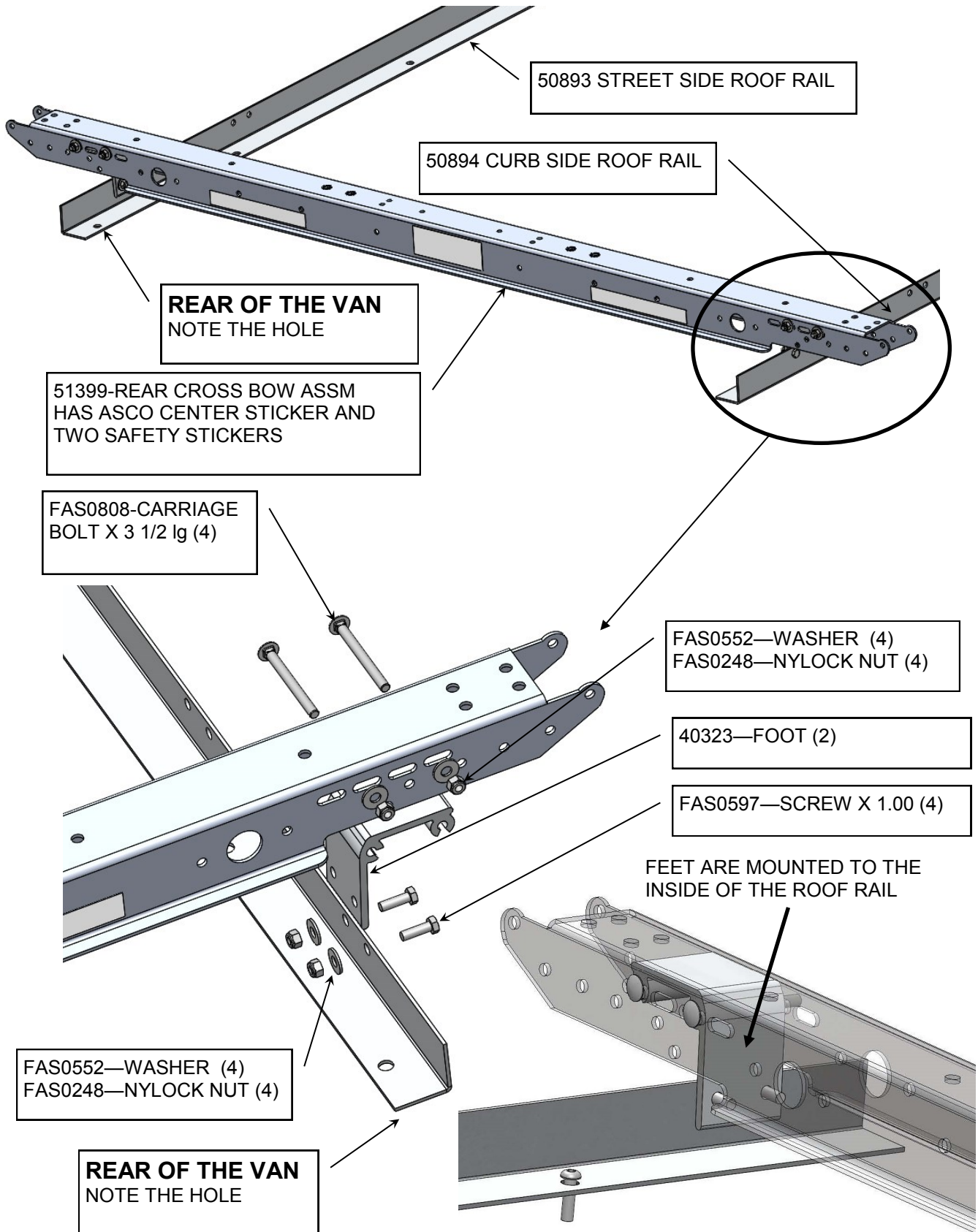

STEP #3 : ASSEMBLE FRONT CROSS BOW TO THE ROOF RAILS

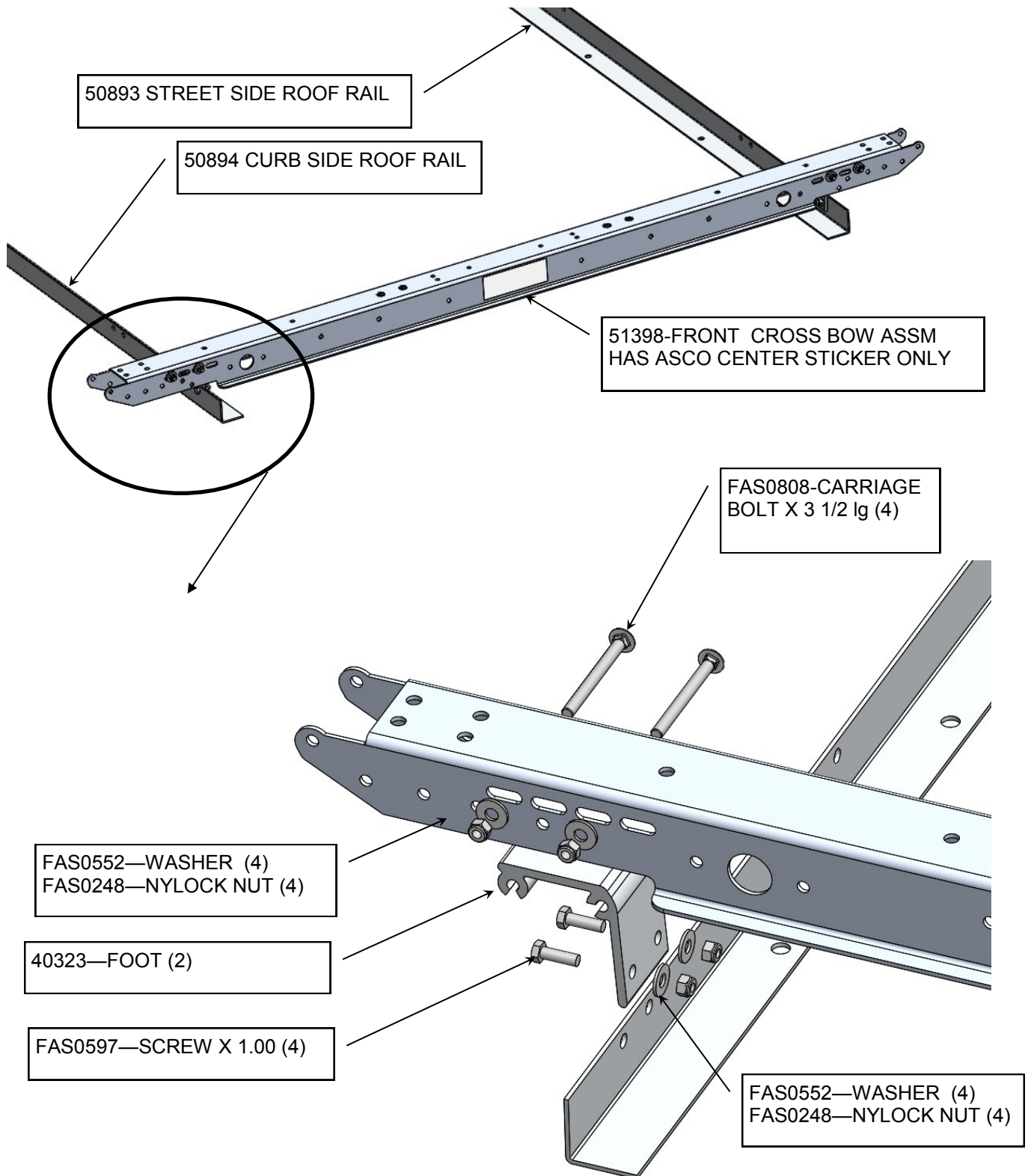

STEP #5 INSTALL RACK ON VEHICLE

REMOVE PLASTIC PLUGS FROM SQUARE DEPRESSIONS ONLY. THESE ARE THE FACTORY MOUNTING POINTS. DO **NOT** REMOVE OTHER PLUGS!! RUN M8-1.25 TAP, FULL DEPTH, TO CLEAN OUT THREADS IN OEM FASTENER IF NECESSARY. MAY HAVE TO REPEAT PROCESS TO GET FULLY CLEAN.

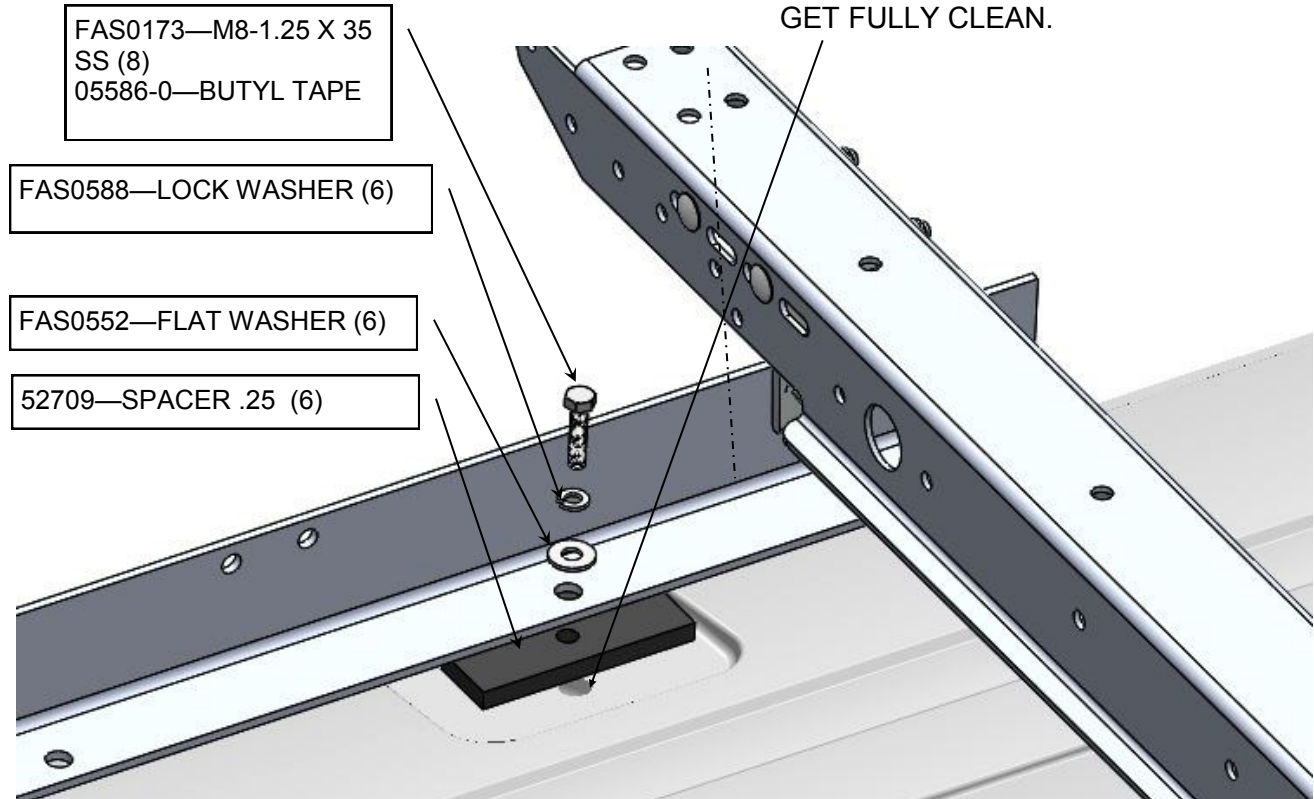

CAREFULLY REMOVE PLASTIC PLUGS FROM FACTORY ATTACHMENT POINTS. NOTE, THEY ARE INSTALLED PRIOR TO VEHICAL BEING PAINTED. IF ROOF CLEARANCE HOLES AND OEM FASTENER ARE MISALIGNED TOO FAR, HOLE IN ROOF SKIN MAY NEED TO BE ENLARGED (AND PRIMERED), AS WELL AS CORRESPONDING HOLE IN ROOF RAIL OF RACK. WRAP SCREWS WITH BUTYL TAPE BENEATH WASHERS, ENOUGH TO FILL HOLE IN RAIL. PUSH SCREWS THRU FOAM, AND RUBBER PAD, ADD ENOUGH SILICONE TO FILL EACH CAVITY. INSTALL SCREWS AND WASHERS AS SHOWN. TORQUE TO 10 TO 12 FT LBS. TORQUE ALL FASTENERS ON RACK ITSELF TO 10-12 FT LBS. DO NOT OVER-TORQUE AS THESE ARE STAINLESS STEEL FASTENERS!

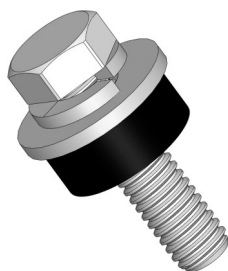

GENERIC PICTURE—MAY NOT LOOK LIKE YOUR FASTENER. MOUNTING SCREW WITH WASHERS AND BUTYL TAPE BEFORE INSTALLATION (LEFT) AND WHAT IT SHOULD LOOK LIKE AFTER INSTALLATION (RIGHT).



COMPLETE DROP DOWN COMBO LADDER RACK



Introduction / Comments:

THIS GRIP LOCK IS DESIGNED TO ADAPT TO YOUR ROOF RAIL AND CROSS BOW KIT. SPECIFICALLY DESIGNED FOR THE LOW ROOF VEHICLES.

FOR A GM SIDE SLIDER DOOR, PLEASE ORDER A 55075 RISER KIT. THIS IS AVAILABLE UPON REQUEST. THESE FEET RAISE THE GRIP LOCK APPROX 2" AND CLEARS THE SIDE SLIDER DOOR. THIS ALSO COMES WITH A WIND DEFLECTOR AS RAISING THIS RACK CHANGED THE HARMONICS.

Note:

It is advised that all fasteners used in this assembly and installation of this Rack should be checked for tightness at the following intervals: @ 2-weeks and again @ 6-weeks of operation. This preventive maintenance step must be completed to ensure your package gives you long service life.

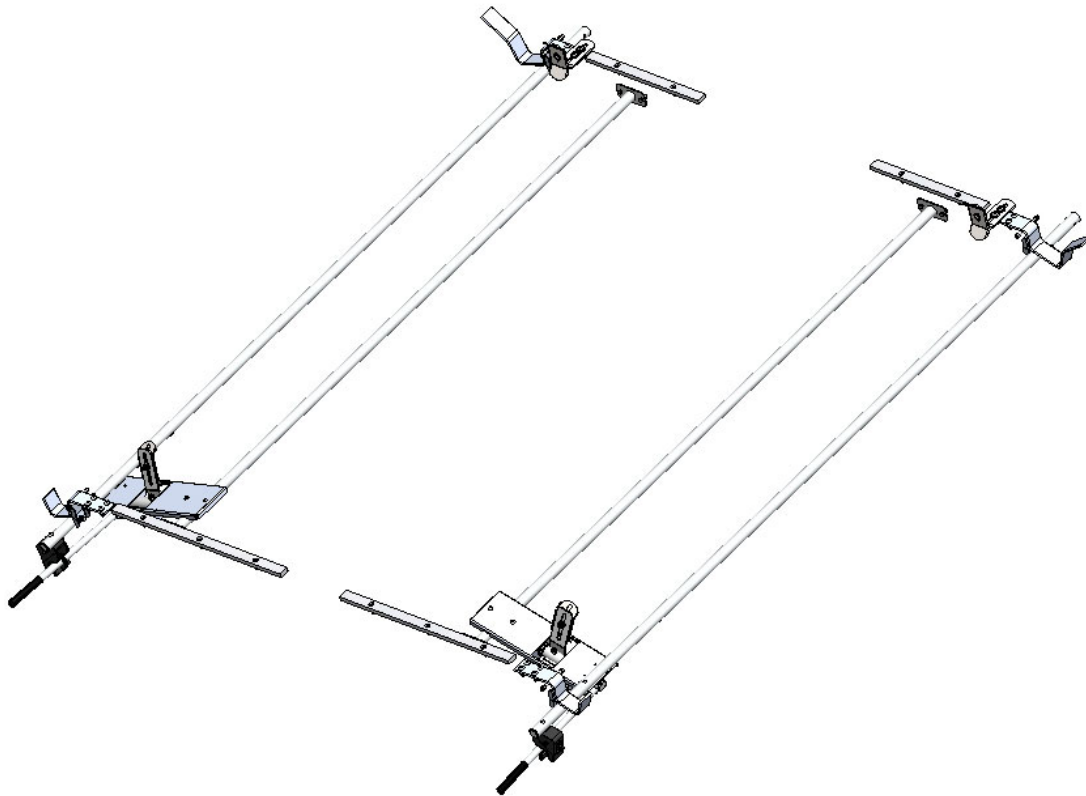

**61-GL2 SERIES / 63-GL2 SERIES
GRIP LOCK, SINGLE & DOUBLE
VARIOUS LOW ROOF VEHICLES**

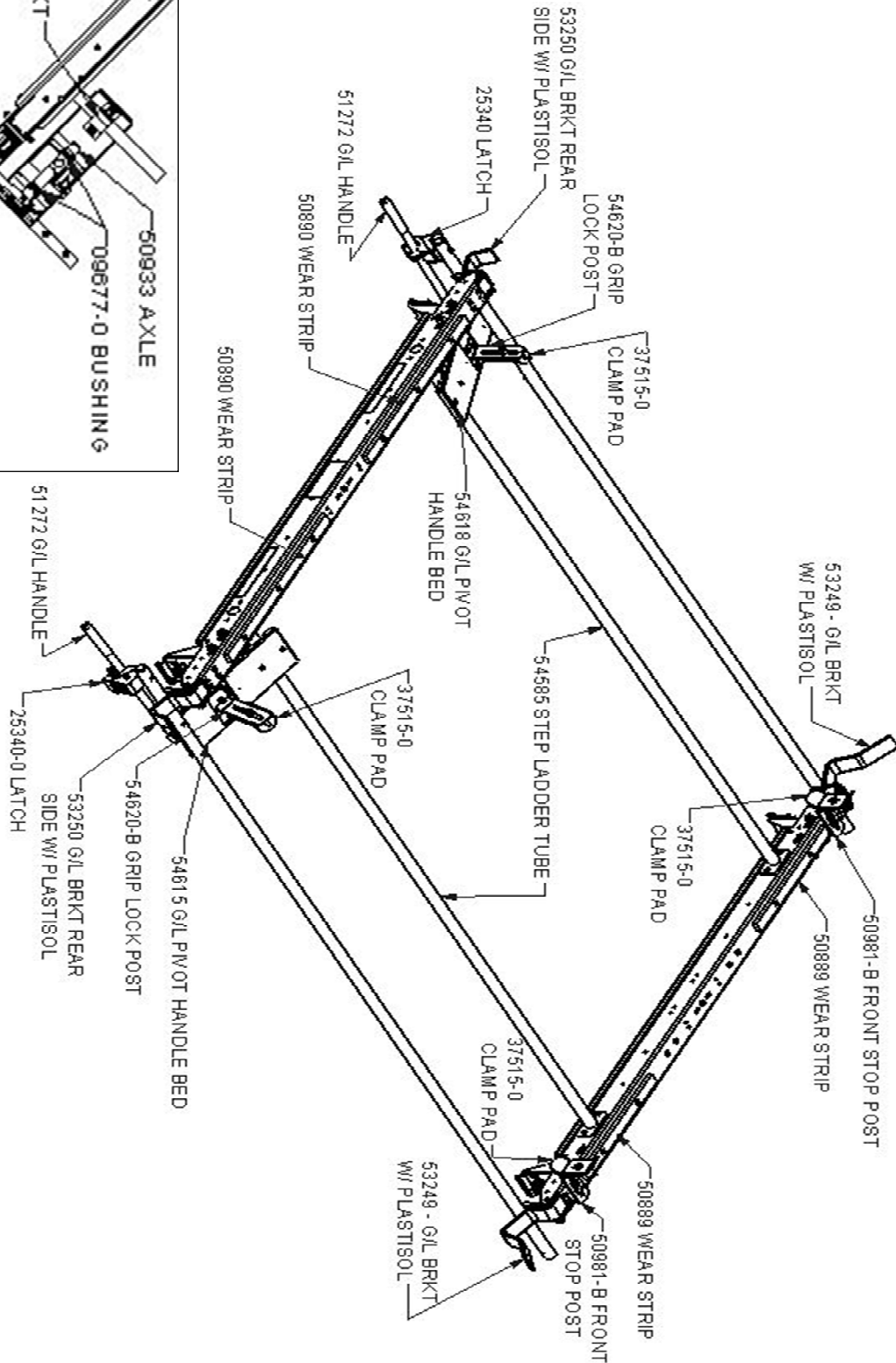
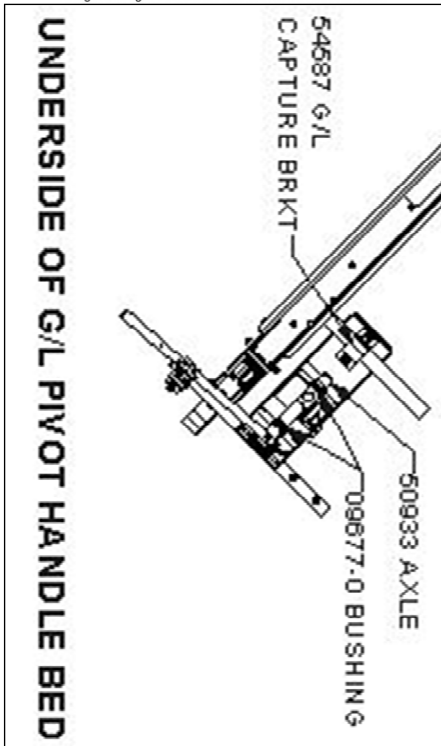

- PRECAUTIONS -



CAUTION
THE USE OF AIR IMPACT TOOLS CAN
OVER-TORQUE FASTENERS AND
CAUSE FASTENER FAILURE!



CAUTION
ALL INSTALLATION HOLES SHOULD BE SEALED
WITH SILICON OR BUTYL SEALANT TO PREVENT
EXHAUST FUMES FROM ENTERING THE VEHICLE!



DANGER
INSPECT FOR FUEL TANK, FUEL LINES, BRAKE LINES, HIGH
VOLTAGE BATTERIES AND ELECTRICAL LINES PRIOR TO
DRILLING TO AVOID DAMAGING CRITICAL VEHICLE SYSTEMS
OR INJURY TO INSTALLER DURING INSTALLATION PROCESS!

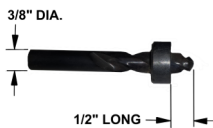

CAUTION
TO AVOID DAMAGING THE VEHICLE ALWAYS USE DRILL
STOPS WHEN DRILLING ANY INSTALLATION HOLES!
ADRIAN AVAILABLE PART #'S 31119-0 (3/8" X 1/2"
DEEP), 31121-0 (1/2" x 1/2" DEEP)



- IMPORTANT WARRANTY REQUIREMENTS -

1. SUBSTITUTING ADRIAN STEEL SPECIFIED FASTENERS FOR ASSEMBLY AND/OR INSTALLATION WILL VOID YOUR PRODUCT WARRANTY.
2. ALL HOLES DRILLED INTO VEHICLE SHOULD HAVE THE RAW METAL EDGES SEALED WITH A SELF-ETCHING PRIMER TO RESIST CORROSION AND POTENTIAL FASTENER POINT FAILURE.
3. ALL FASTENERS USED IN THE INSTALLATION OF THIS PRODUCT SHOULD BE TIGHTENED TO THE TORQUE(S) SPECIFIED IN THESE INSTRUCTIONS.
4. THESE INSTRUCTIONS SHOULD BE KEPT WITH THE VEHICLE.

THE BASIC TOOLS NEEDED FOR MOST INSTALLATIONS



DRILL



DRILL BIT WITH
STOP

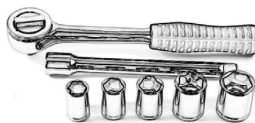

RATCHET, SOCKETS
AND/OR WRENCHES



SCREWDRIVERS



MEASURING TAPE

ADDITIONAL TOOLS MAY BE NEEDED FOR THIS INSTALLATION AND THEY WILL BE IDENTIFIED IN THE STEPS THAT FOLLOW.

BAG54629 - FASTENER BAG

ITEM NO.	PART NUMBER	DESCRIPTION	QTY.
1	BAG0507-A	5" x 7" 3MIL AUTOBAG	1
2	FAS0248	Nut, Nylon Insert Lock, 5/16-18 SST	13
3	FAS0811	SCREW,CAP, 5/16-18X3.50 SS	2
4	FAS0813	Screw, BHCS, 5/16-18X1.00, SS	9
5	FAS0799	Screw, Hex Hd, 5/16-18x0.75 SS	4
6	FAS0552	Washer, Flat, 5/16, SST	4
7	FAS0820	SCREW,BHCS 3/8-16X1.0 SS	6
8	FAS0110	Nut,Hex Nylk 3/8-16 SS W	8
9	FAS0701	Screw,BHCS 3/8-16x1.25 SS	2
10	FAS 0720	Washer,Flat 3/8 SS	2
11	FAS0588	Washer, Lock, Split, 5/16, SS	2

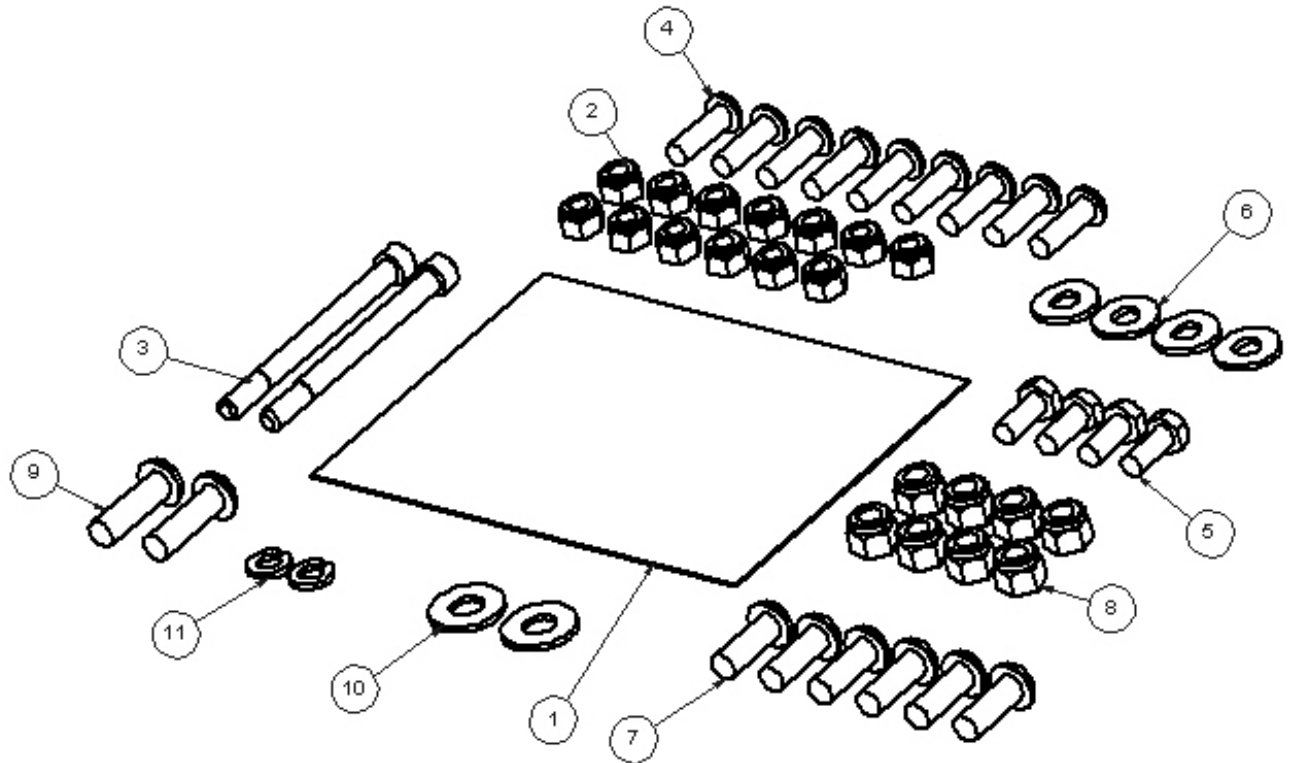



**STEP #1A : ASSEMBLE CURB SIDE WEAR STRIPS TO THE ROOF BOWS
ALL RACKS**

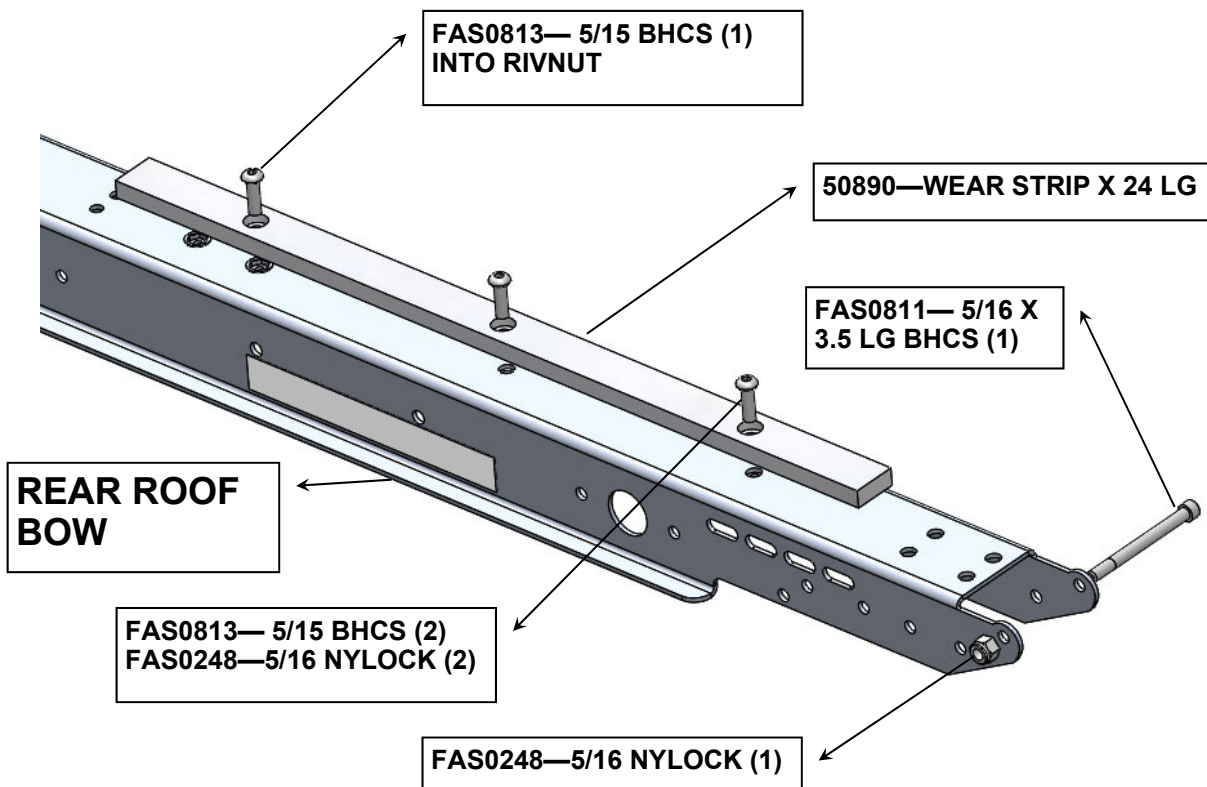
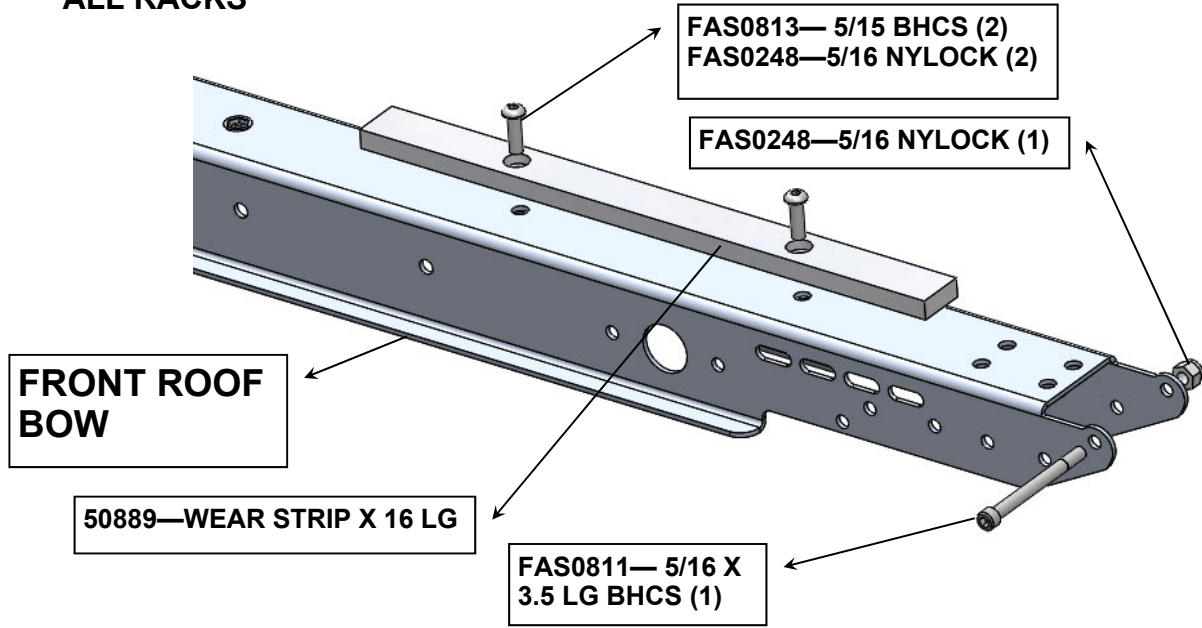



**STEP #1B : THIS IS THE FINISHED CURB SIDE ASSEMBLY FOR A FORD TRANSIT SHIP THRU RACK.
CONTINUE TO STEP #3 FOR A DOUBLE GRIP LOCK (ANOTHER KIT)
PLACE ASSEMBLED CROSS BOWS FROM STEP #1 BACK IN HDW BOX**

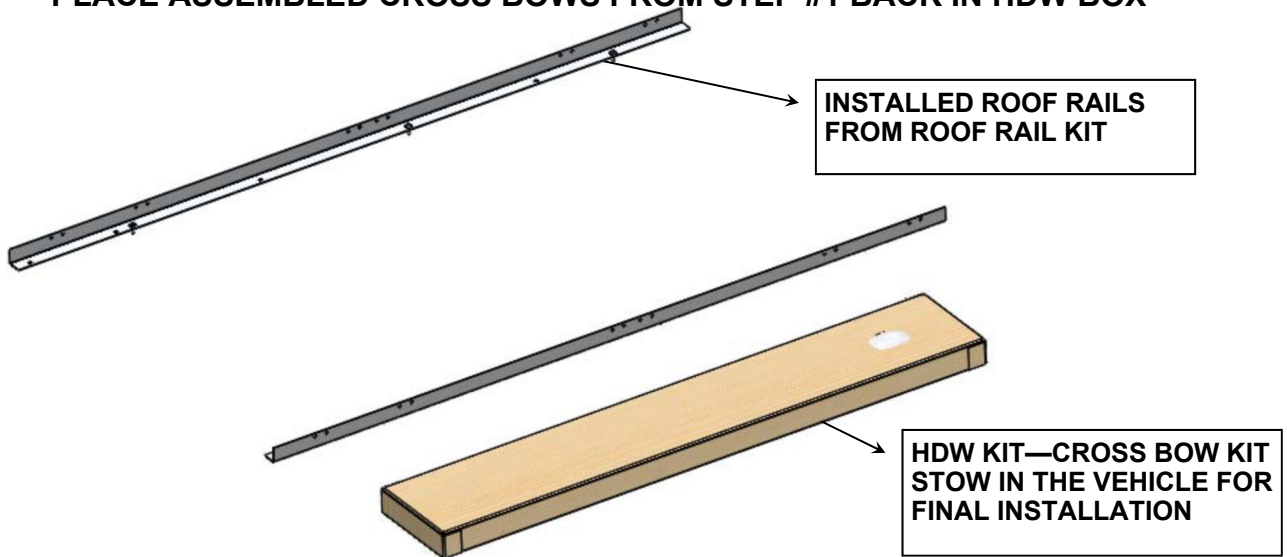

**STEP #2A : ALL RACKS, ASSEMBLE STREET SIDE WEAR STRIPS TO THE ROOF BOWS.
THIS IS ALL THAT CAN BE INSTALLED FOR THE TRANSIT SHIP THRU—
STOW THE REMAINDER OF THE PARTS FOR FINAL INSTALL.**

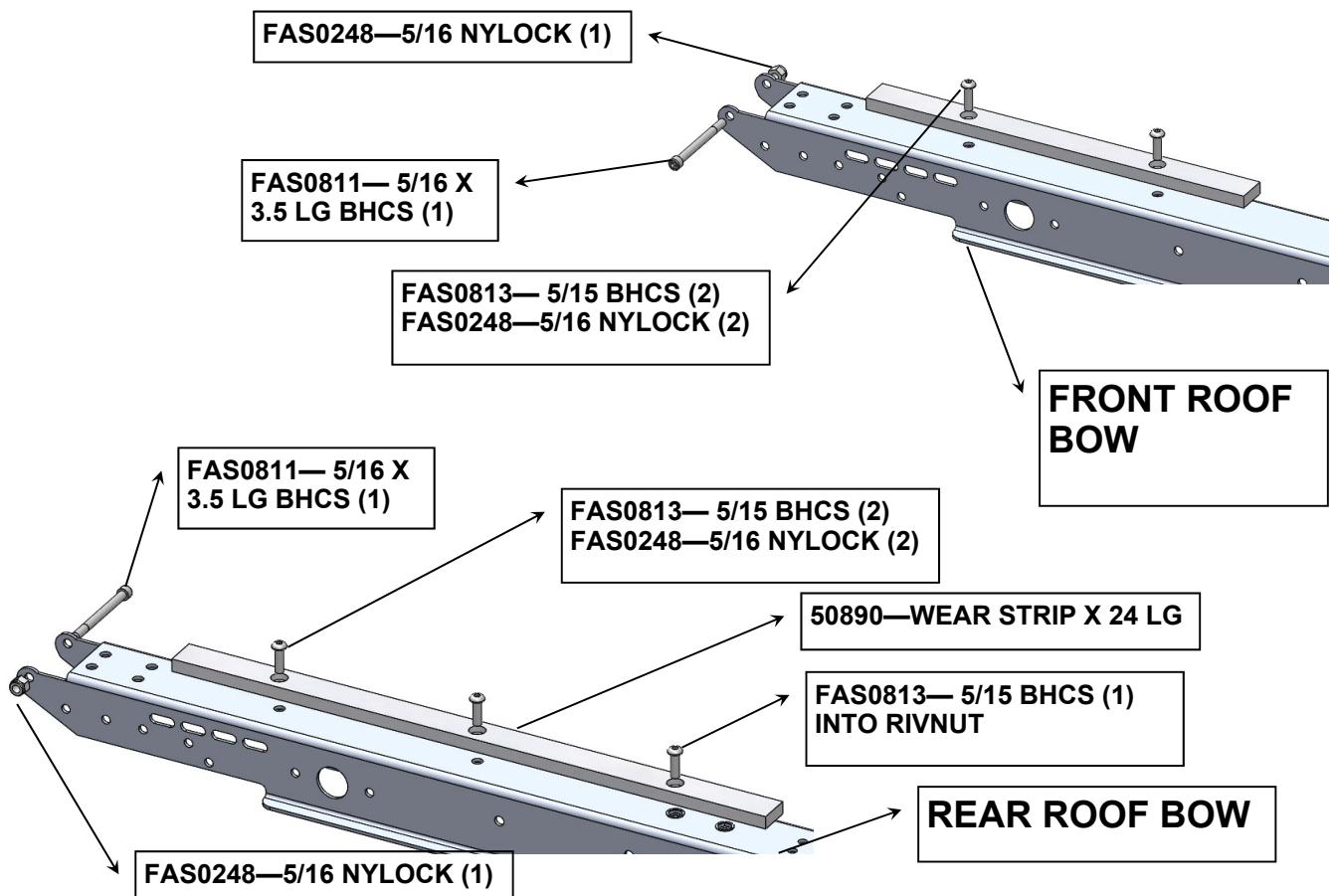



**STEP #2B : FOR A FORD TRANSIT SHIP THRU ONLY—THIS IS THE COMPLETED ASSEMBLY OF A DOUBLE GRIP LOCK.
PLACE ASSEMBLED CROSS BOWS FROM STEP #1 & 3 BACK IN HDW BOX
CONTINUE TO STEP 5 FOR A COMPLETE ASSEMBLY / INSTALL**

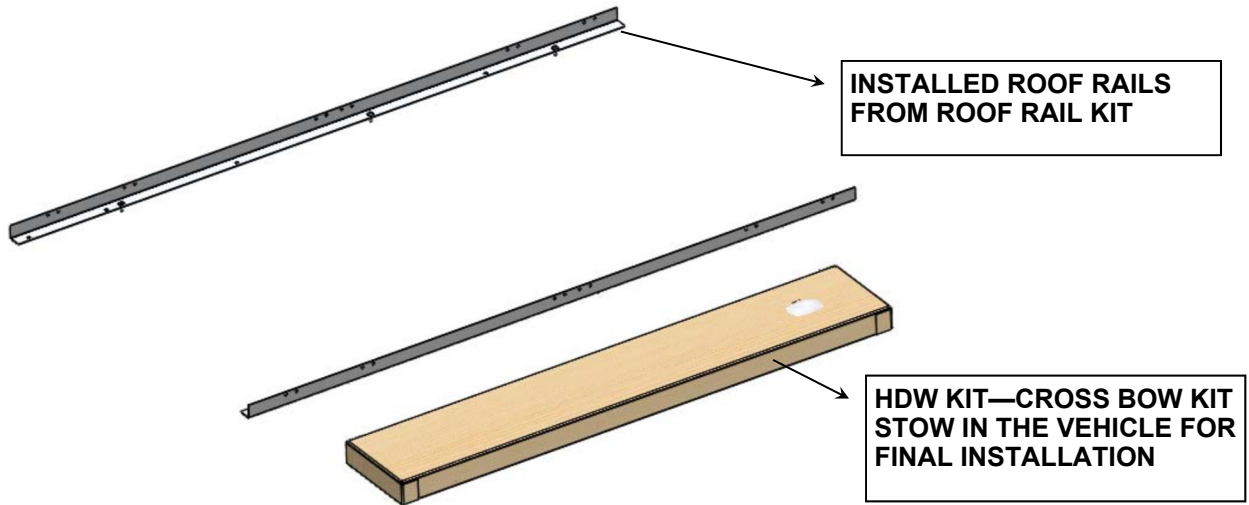

**STEP #3A : GM SHIP THRU ONLY—SINGLE GRIP LOCK
THIS IS THE COMPLETED ASSEMBLY**

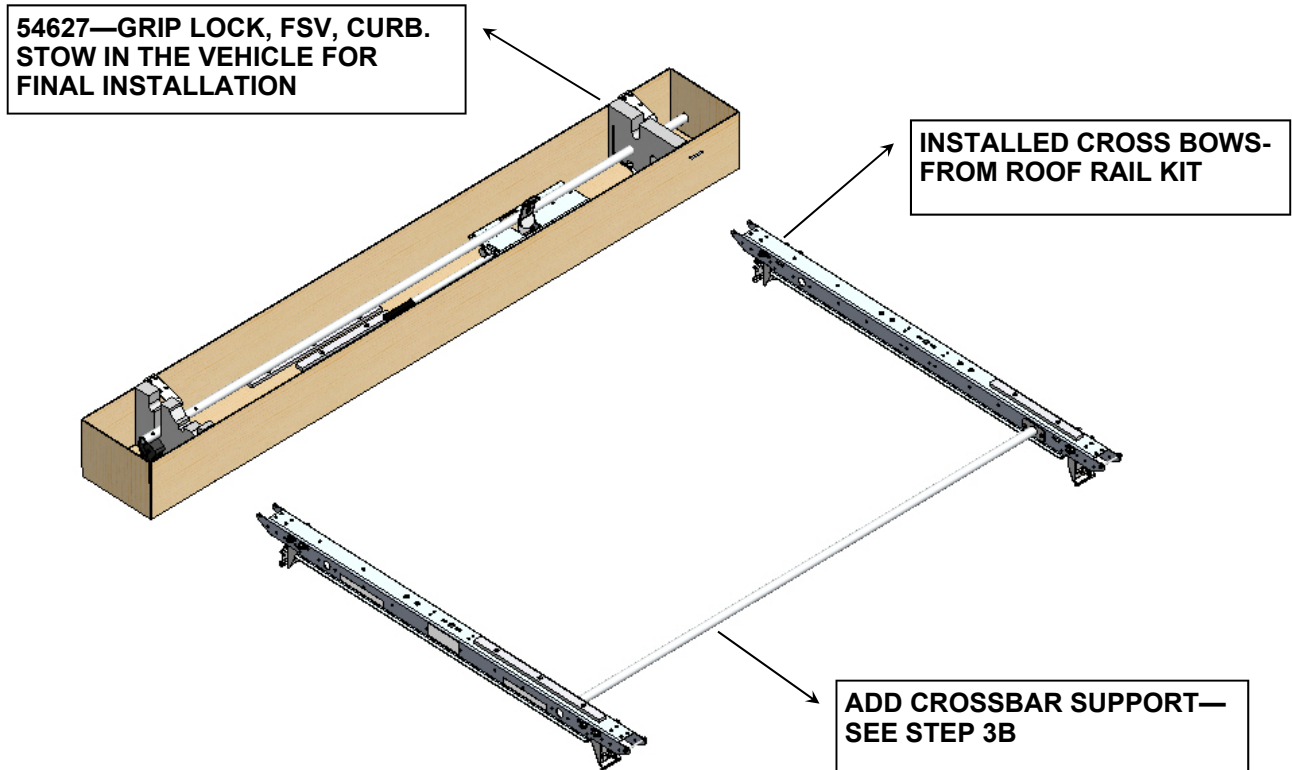



STEP #3B: ADD CROSS SUPPORT FOR SLIDE BED

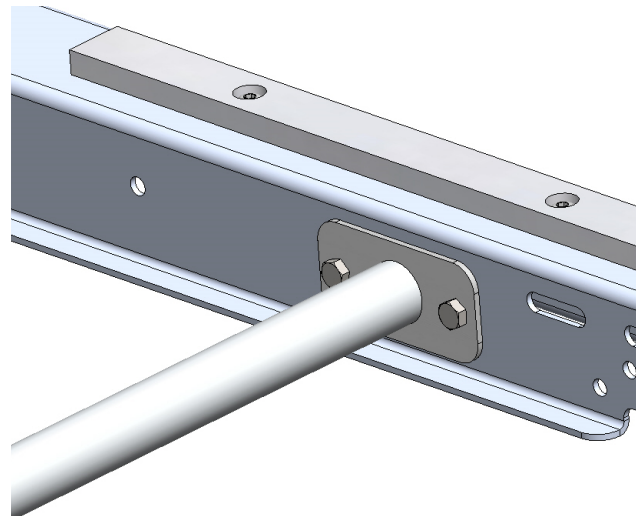
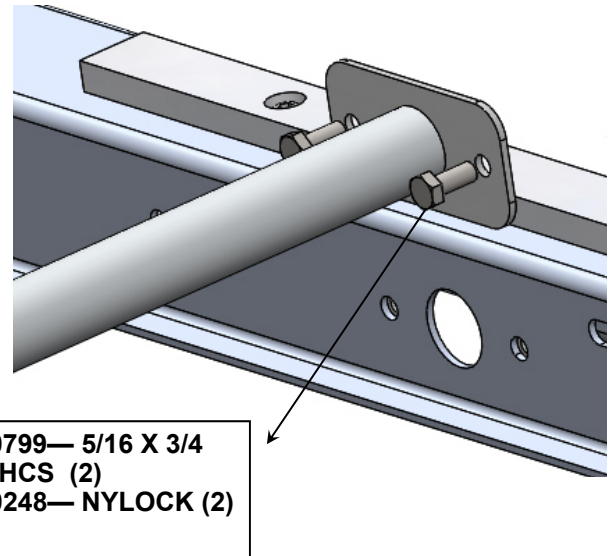
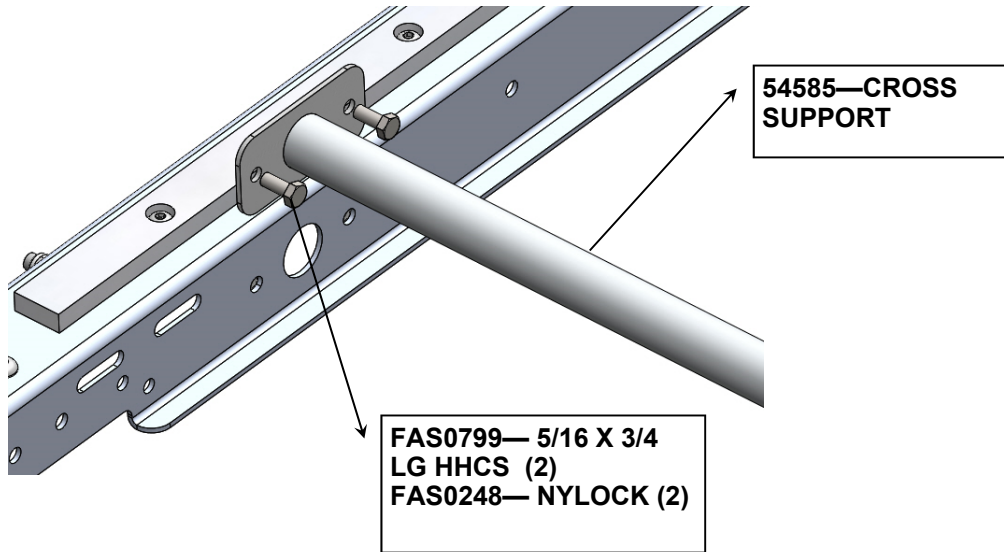



**STEP #4A : GM SHIP THRU ONLY—DOUBLE GRIP LOCK
THIS IS THE COMPLETED ASSEMBLY**

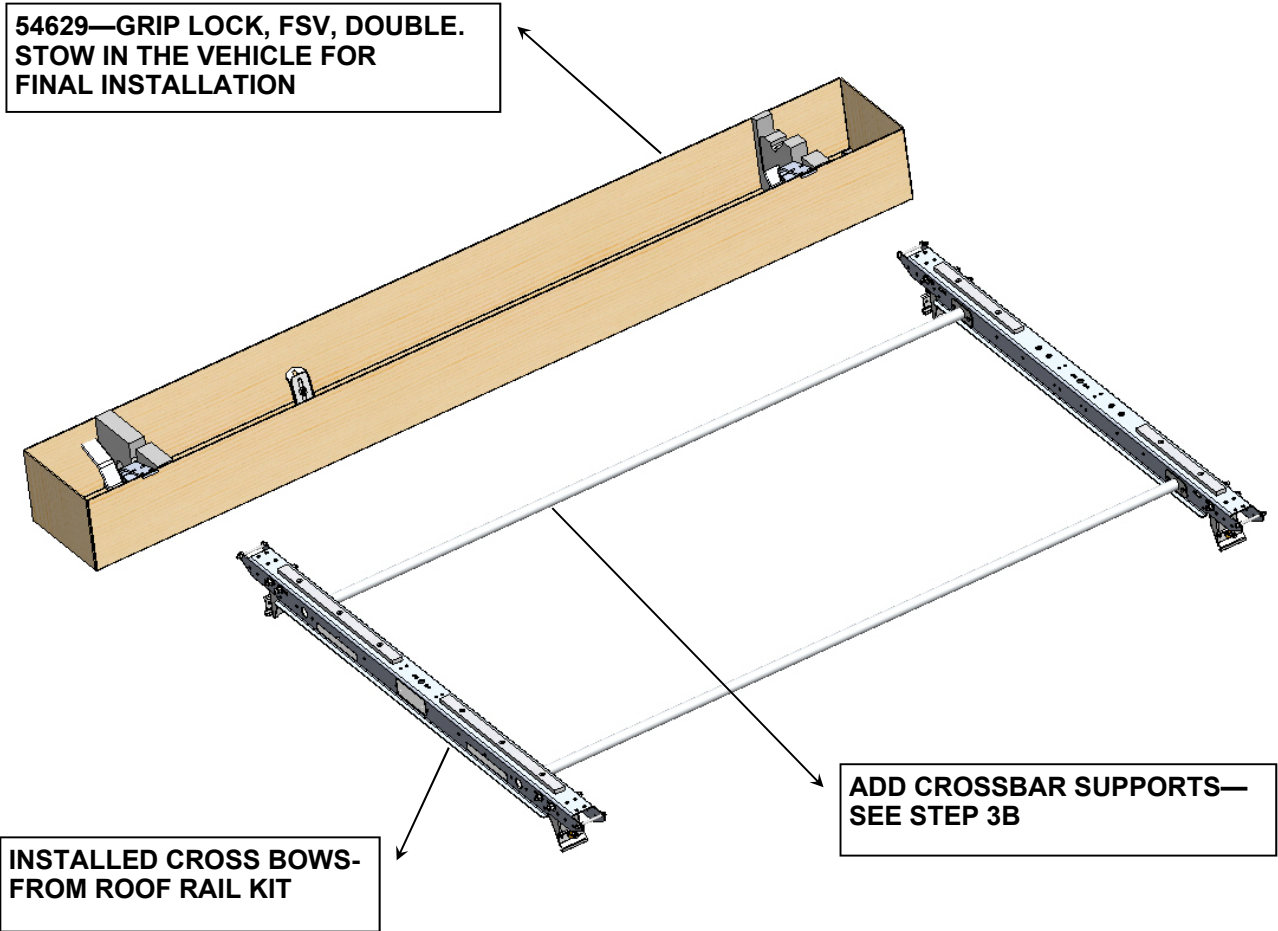

STEP #5 : INSTALL CURB SIDE SUB ASSEMBLY ON THE ROOF BOWS

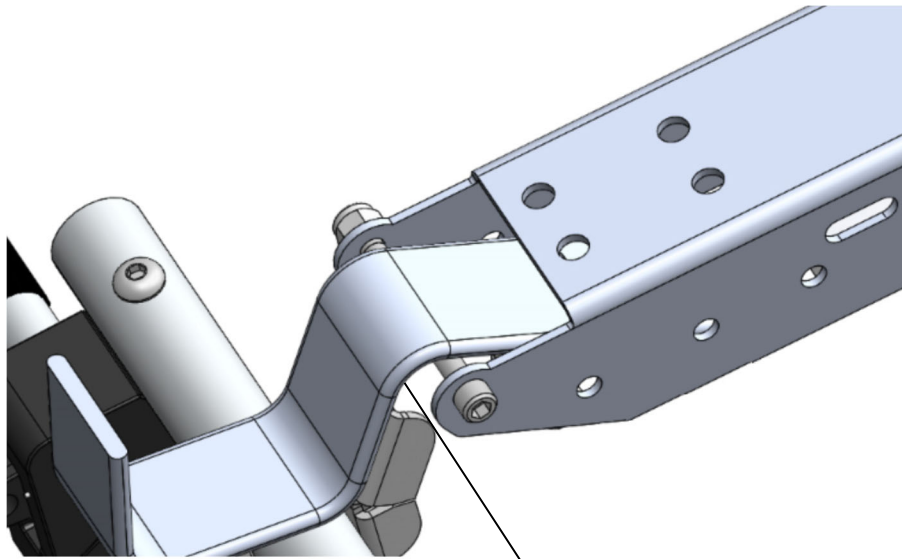

**PIVOT AND PUT
GRIP LOCK HOOKS
INTO ROOF BOWS**

REAR ROOF BOW

**FAS0820— 3/8 X 1
LG BHCS (4)
FAS0110— NYLOCK (4)**

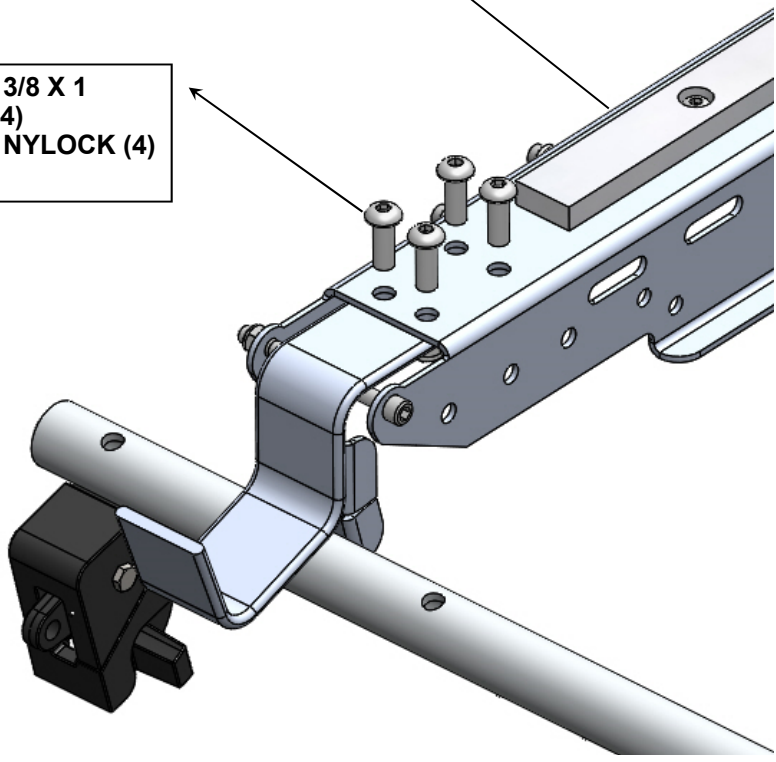

STEP #6: FRONT ROOF BOW ASSEMBLY –CURB SIDE

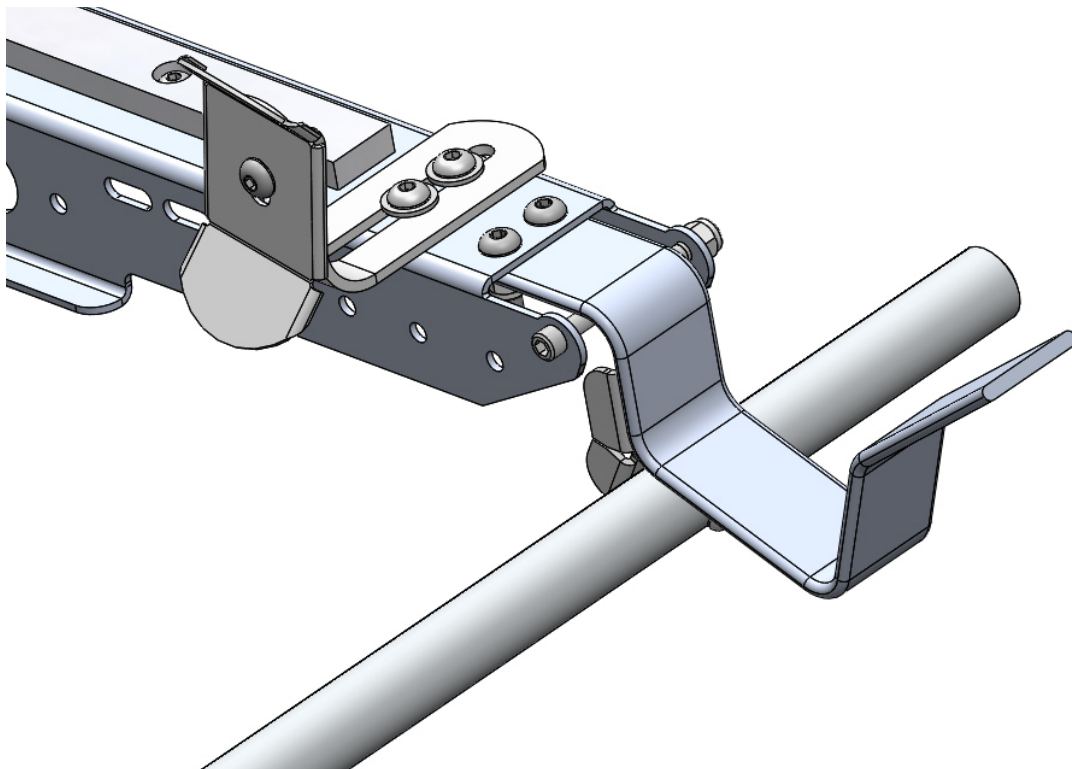
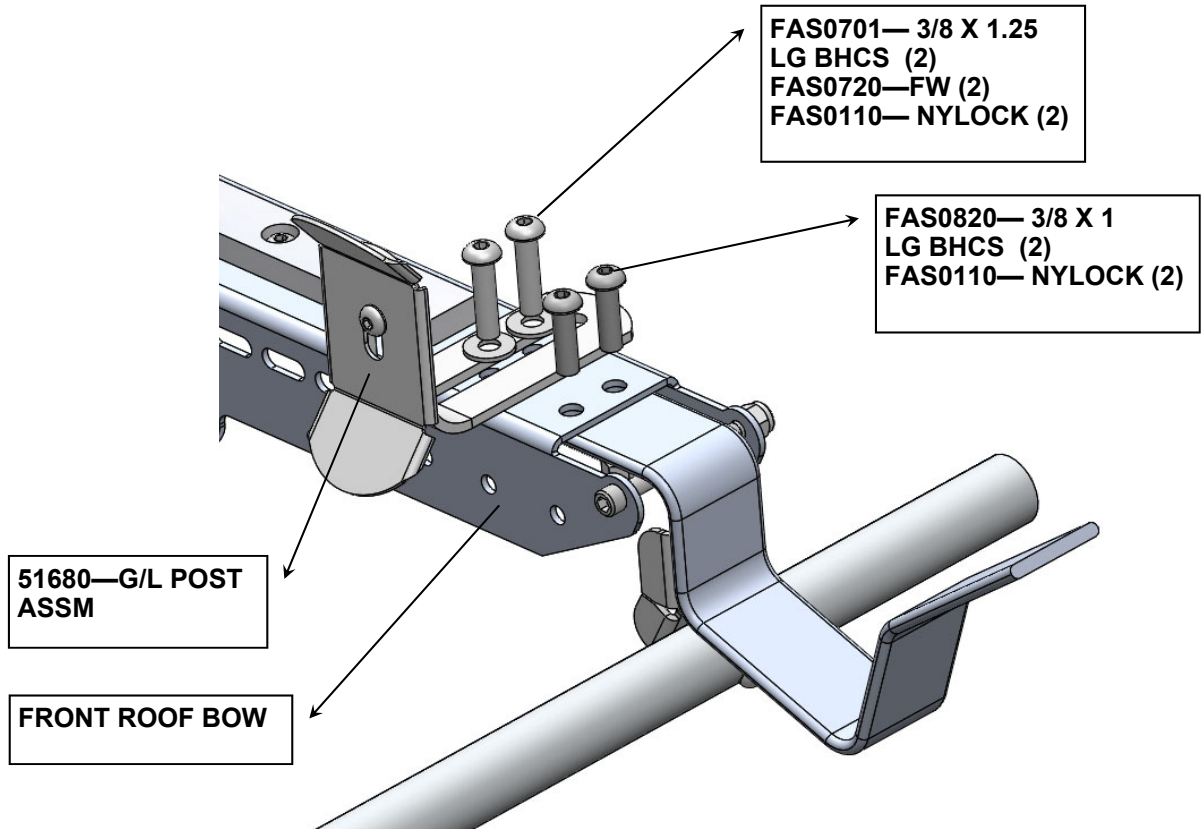



STEP #6: ADD CROSS SUPPORT FOR SLIDE BED –CURB SIDE

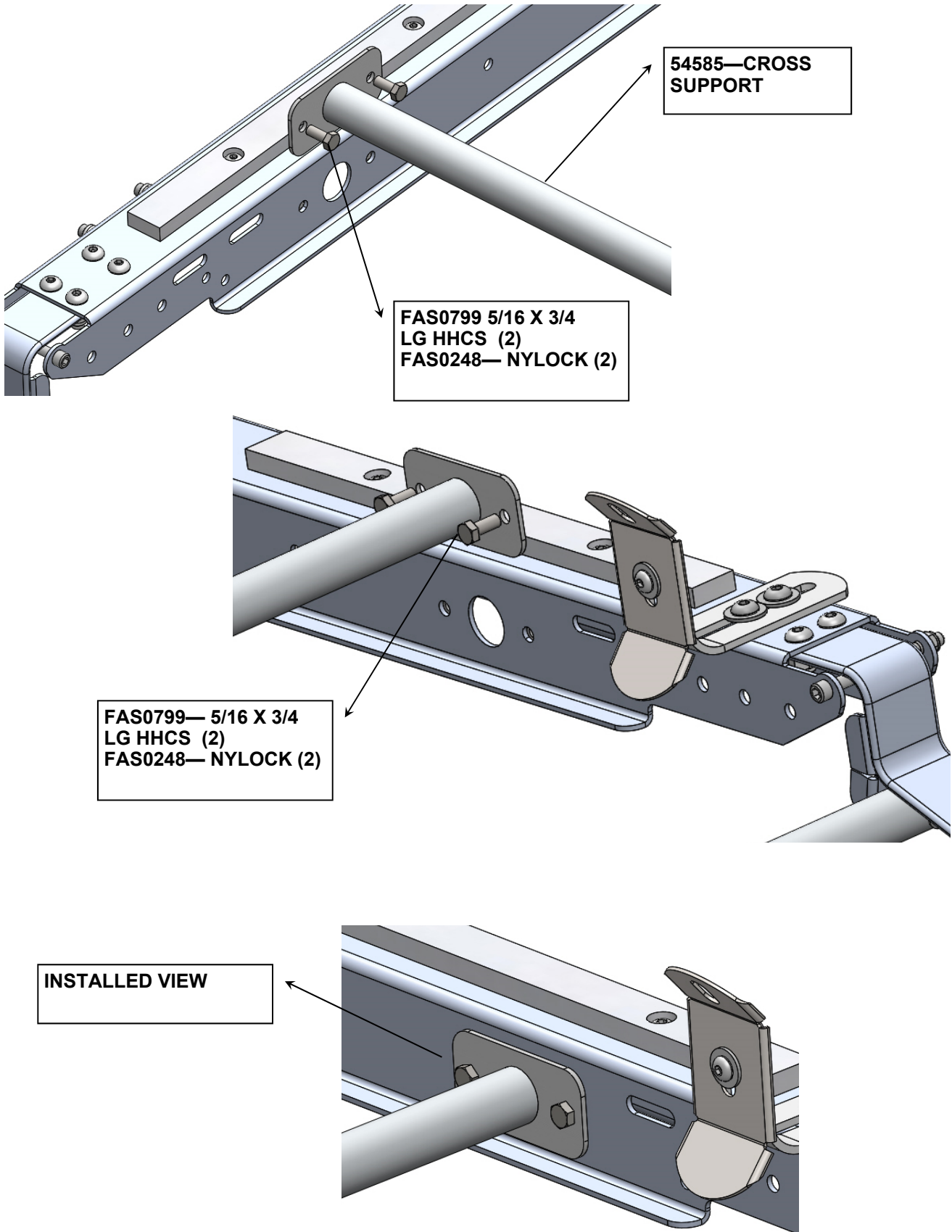



STEP #7A: EXTENSION LADDER—ADD BED SLIDE TO THE CROSS SUPPORT – CURB SIDE.

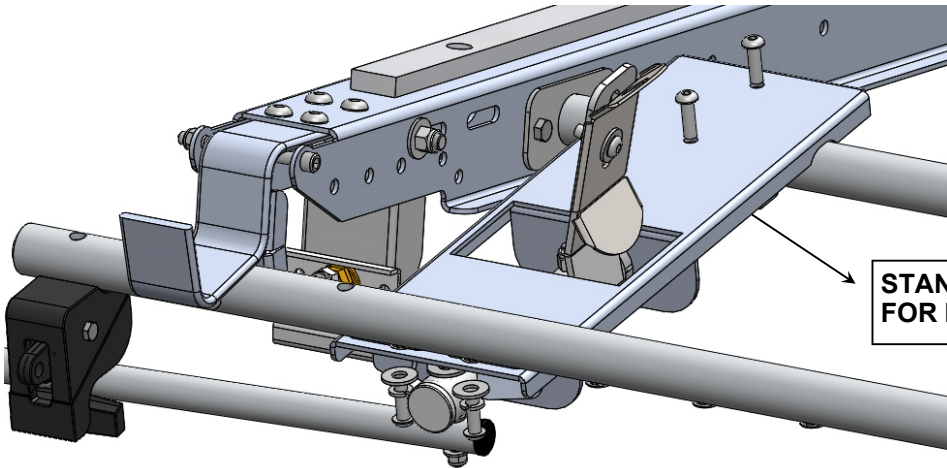

STANDARD LOCATION FOR EXTENSION LADDERS

FAS0813— 5/16 X1 LG BHCS (2)
FAS0588-LW (2)
FAS0552— FW (2)

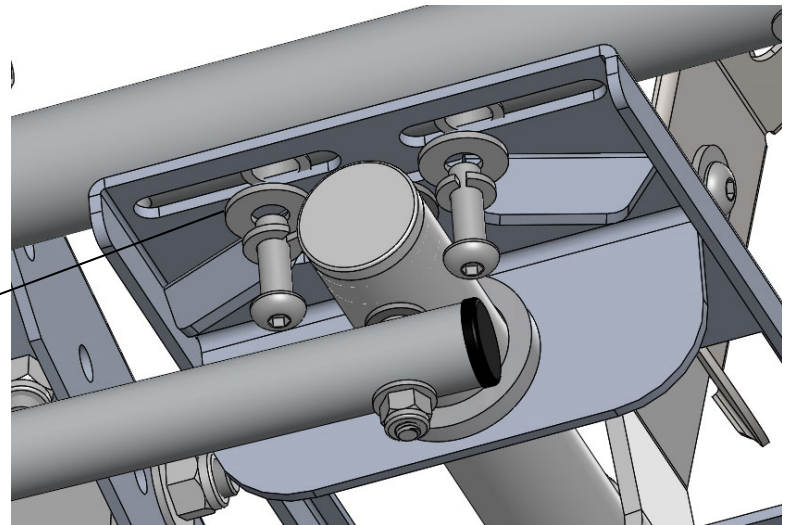

FAS0813— 5/16 X1 LG BHCS (2)
FAS0552— FW (2)
FAS0248-NYLOCK (2)

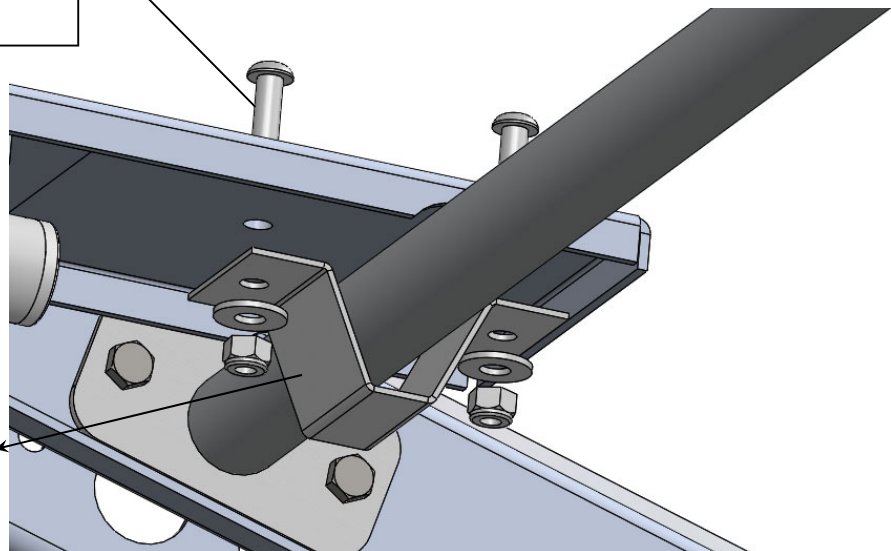

54587—CAPTURE BRACKET



**STEP #7B: A-FRAME LADDER— ADD BED SLIDE TO THE CROSS SUPPORT
—CURB SIDE.**

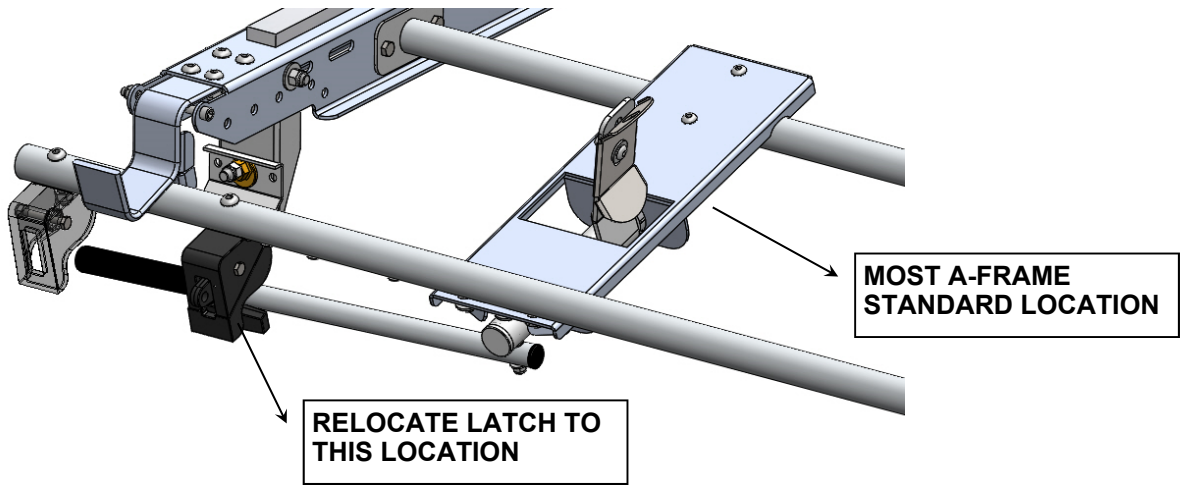

ANOTHER OPTIONAL MTG LOCATION

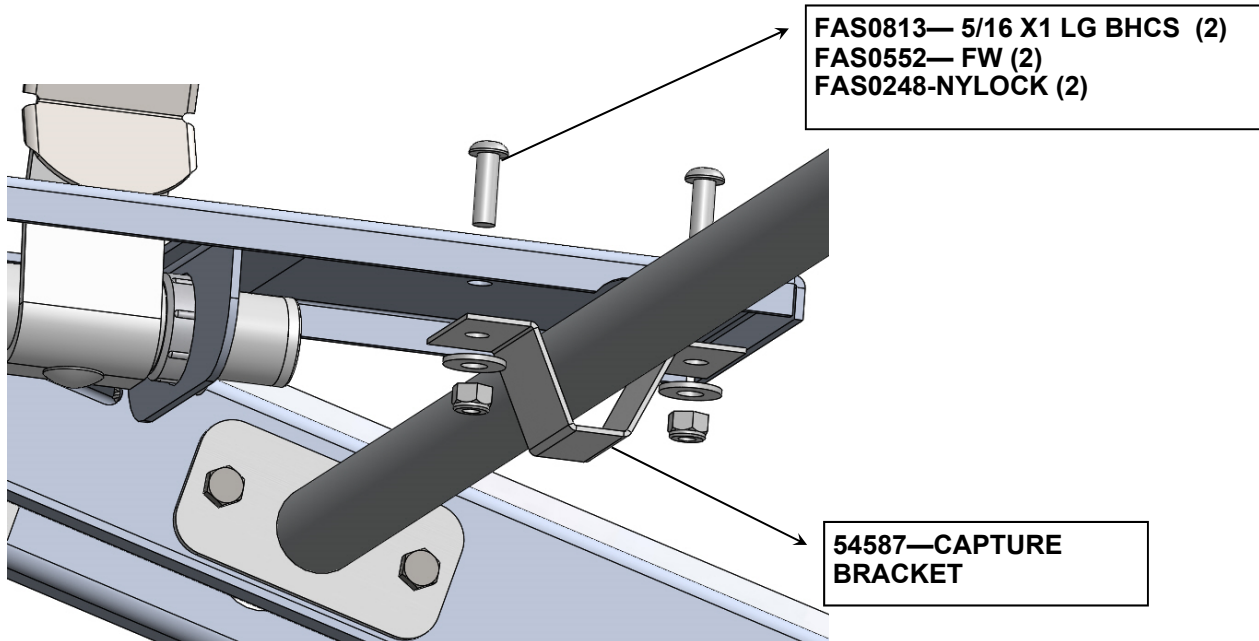
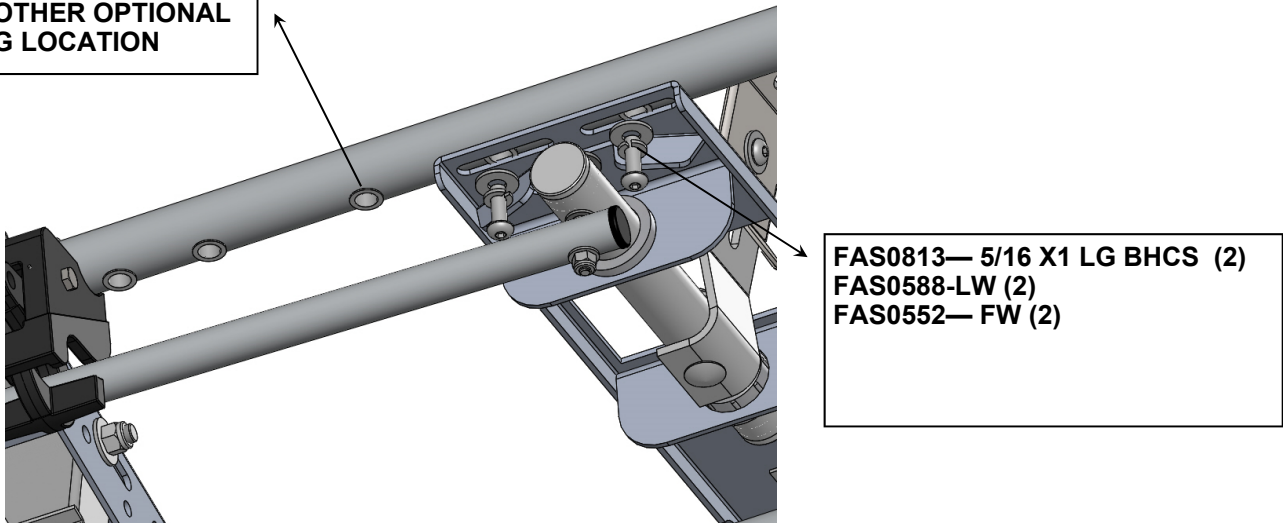



STEP #8: FOLLOW STEPS 1 THRU 7 FOR YOU STREET SIDE ASSEMBLY

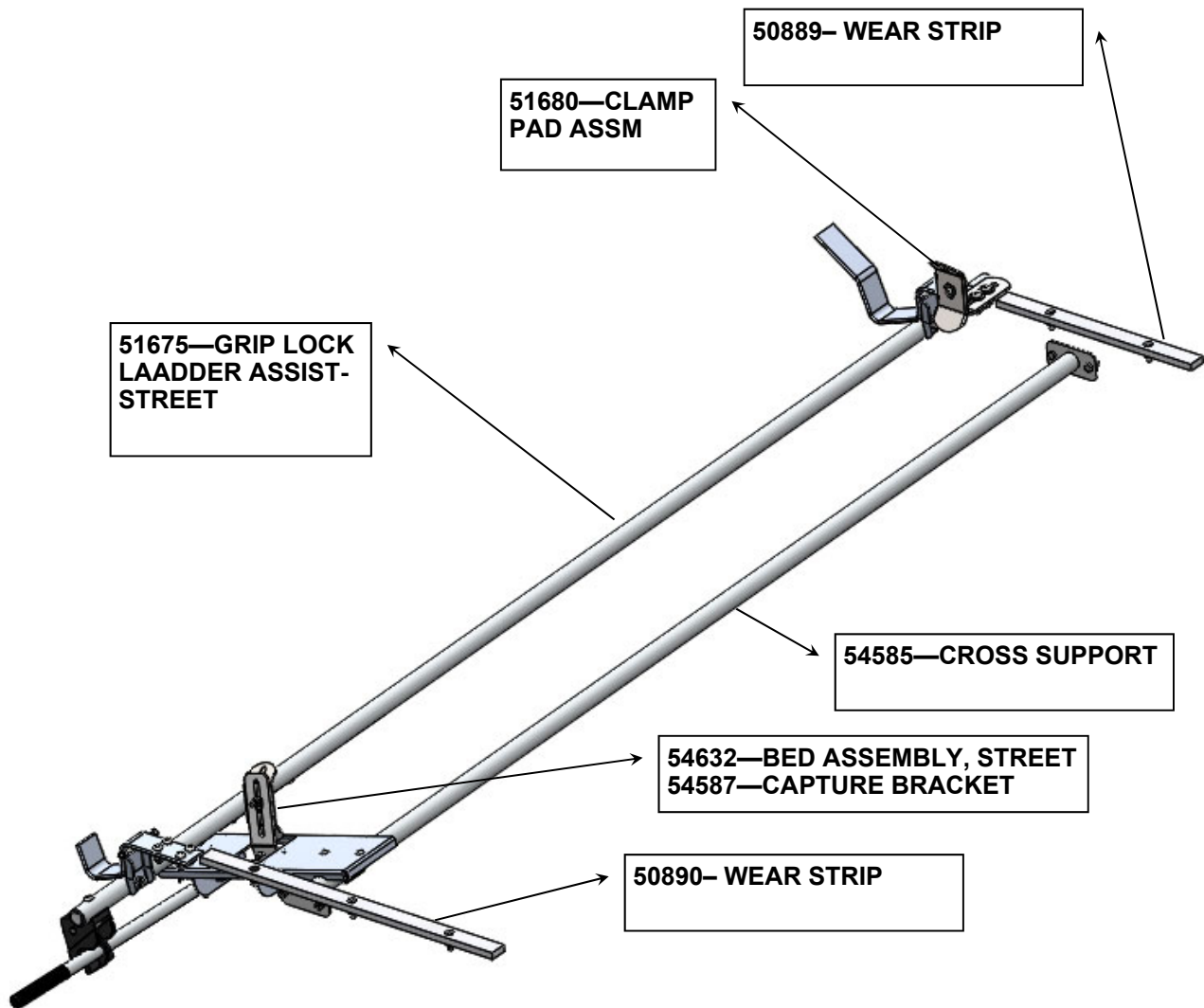

**DOUBLE CHECK ALL FASTENERS LOCATIONS TO BE SURE THAT ALL FASTENERS ARE TIGHTENED TO SPECIFICATIONS.
YOUR INSTALLATION IS NOW COMPLETE!
STOW THIS COPY IN THE VEHICLE FOR FUTURE REFERENCES!**



STEP #9: YOUR ASSEMBLY IS NOW COMPLETE

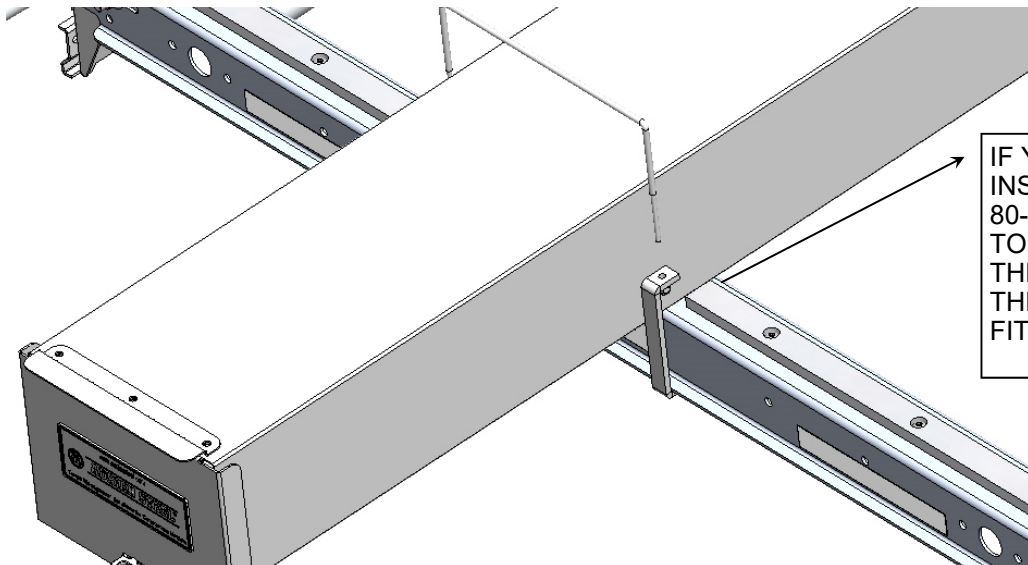
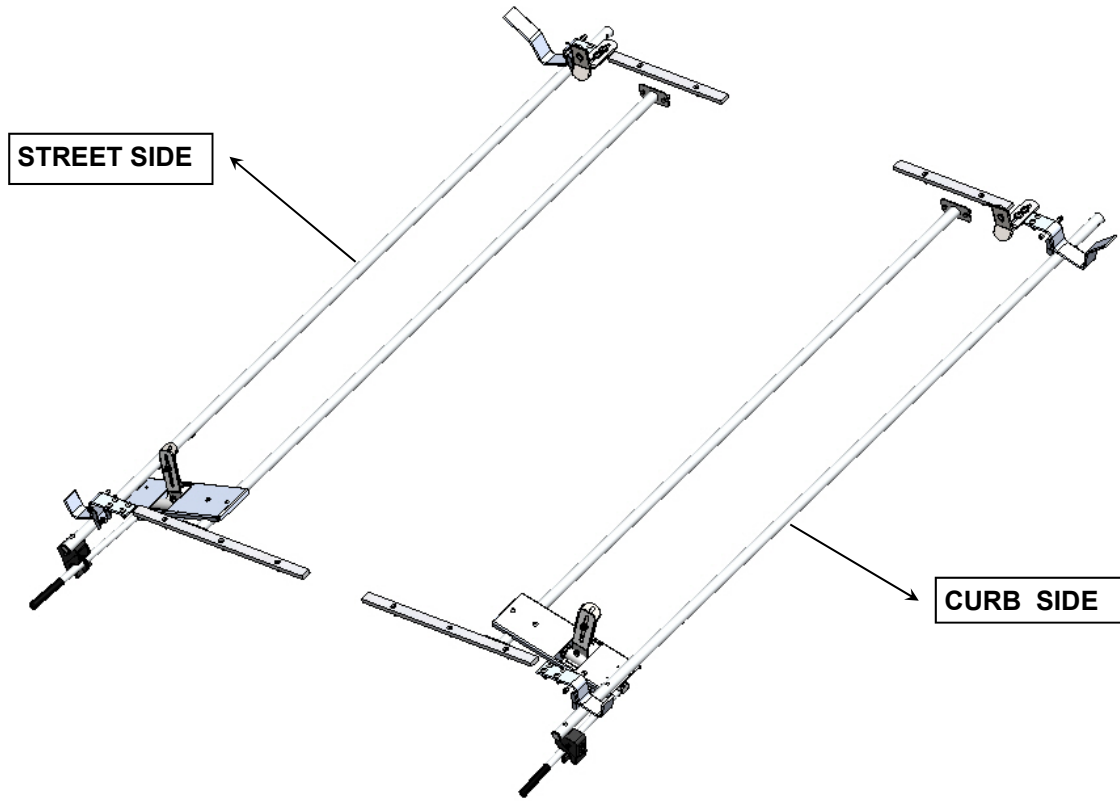

IF YOU WANT TO
INSTALL AN 80-1LR OR
80-2LR, YOU MAY HAVE
TO REMOVE A 1/2" FROM
THE WEAR STRIP FOR
THE ALUM CONDUIT TO
FIT.

**DOUBLE CHECK ALL FASTENERS LOCATIONS TO BE SURE THAT ALL
FASTENERS ARE TIGHTENED TO SPECIFICATIONS.
YOUR INSTALLATION IS NOW COMPLETE!
STOW THIS COPY IN THE VEHICLE FOR FUTURE REFERENCES!**



STEP #10A: HOW TO ADJUST THE CLAMP PADS



FRONT BRACKET

ADJUST VERTICALLY TO YOUR LADDER

ALL OF THE HORIZONTAL ADJUSTMENT IS IN THIS BRACKET.

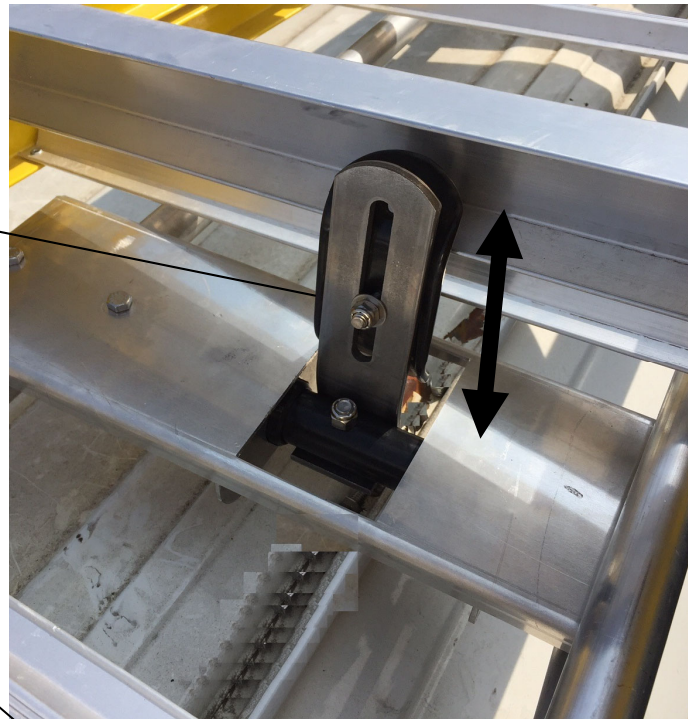

ADJUST VERTICALLY TO YOUR LADDER. SHOWING A STEP LADDER

SLOTS FOR ADJUSTMENT

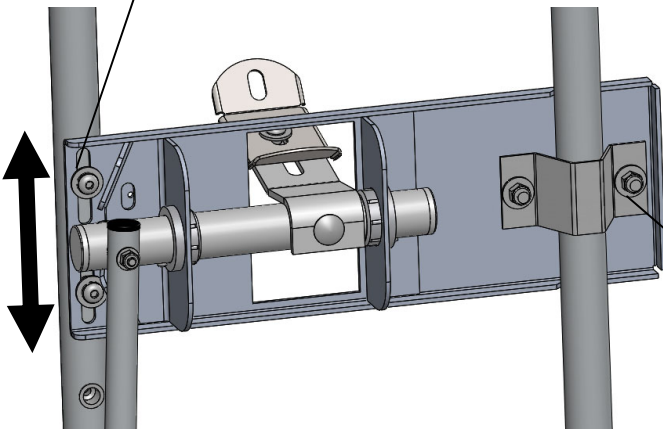

LOOSEN FASTENERS TO ADJUST CLAMP

**DOUBLE CHECK ALL FASTENERS LOCATIONS TO BE SURE THAT ALL FASTENERS ARE TIGHTENED TO SPECIFICATIONS.
YOUR INSTALLATION IS NOW COMPLETE!
STOW THIS COPY IN THE VEHICLE FOR FUTURE REFERENCES!**



STEP #10B : HOW TO ADJUST THE CLAMP PADS

- A) Load your ladder onto the ladder rack (see page 14) and latch the HANDLE BAR into the HANDLE LATCH.
- B) Now slide the ladder back towards the rear of the vehicle and slide the rear CLAMP BRACKET to fit snug over and against the top ladder rung. ** See bottom illustration for STEP LADDERS ! **
SEE ILLUSTRATION BELOW.
- C) Next slide the FRONT STOP POST at the front of the ladder rack back towards the rear of the vehicle and fit the front CLAMP BRACKET to the top ladder rung the same as the rear.
- D) Firmly tighten both front and rear CLAMP BRACKETS to their posts and tighten snug the FRONT STOP POST to the front CROSS SUPPORT.
- E) Now unlatch the HANDLE BAR and unload your ladder. Next loosen the FRONT STOP POST and slide it out towards the rear of the vehicle 1/2" and FIRMLY RETIGHTEN !
YOUR LADDER RACK SHOULD NOW BE ADJUSTED FOR YOUR LADDER.

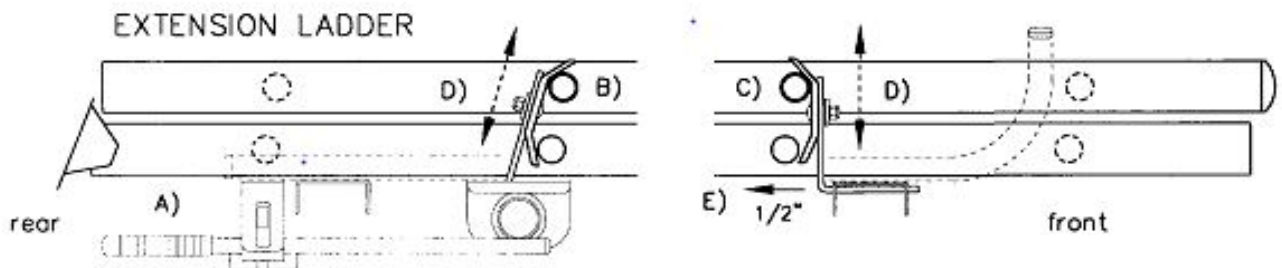

CAUTION: Never clamp up the first step and the head of the STEP LADDER !

Front CLAMP BRACKET must be attached like this !

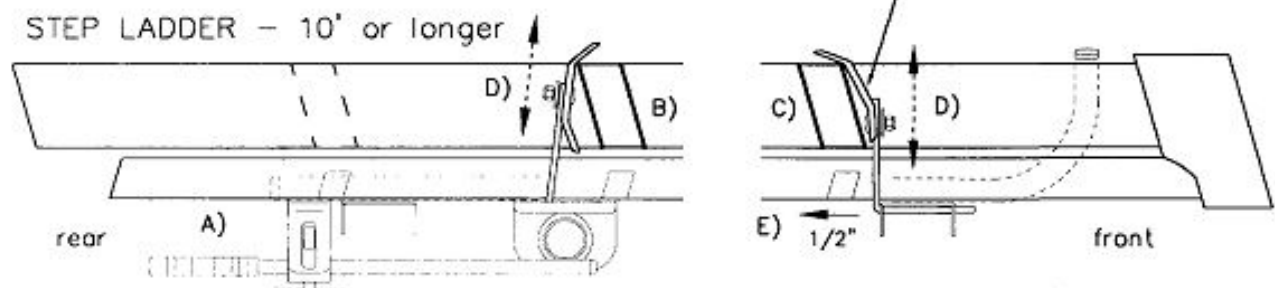

**DOUBLE CHECK ALL FASTENERS LOCATIONS TO BE SURE THAT ALL FASTENERS ARE TIGHTENED TO SPECIFICATIONS.
YOUR INSTALLATION IS NOW COMPLETE!
STOW THIS COPY IN THE VEHICLE FOR FUTURE REFERENCES!**