



PRODUCT WEIGHT
157 lbs

WIDTH x DEPTH x HEIGHT
91" X 113" X 18"

CAPACITY
28 FOOT EXT

COLOR
Aluminum / Black

CATALOG NUMBER
DDL63FTM

PRODUCT FEATURES

This double drop down rack and roof cross-bow kit is designed to fit the Ford Transit, Mid roof vehicles, 130 and 148 wheel base. The drop down will carry 20 to 28 foot extension ladders, and 10-12 foot step ladders. Step ladders shorter than 10' require DDLRSLK2 step ladder kit. Step ladders wider than 26" at the base require the wide step ladder add on, part 57107. Ladders with extensive gussets or platform step ladders may not be compatible with the rack.

The cross-bow kit is secured to the Ford Transit by OEM supplied fastening points.

SEE PAGE 2 FOR APPLICATION NOTES AND ACCESSORIES, OTHER PRODUCTS THAT WORK WITH THIS UNIT.



**DROP DOWN, DOUBLE, FORD TRANSIT, MID
ROOF VEHICLES**

CATALOG NUMBER **DDL63FTM**

PRODUCT APPLICATION

This Double drop down unit is designed to fit 2016 and new Ford Transit, mid roof vehicles.

ACCESSORIES THAT WILL WORK WITH THIS PRODUCT

CATALOG NUMBER	DESCRIPTION
DDL63FTM	STEP LADDER KIT
69-DDCSFTM	DDL63 EXTENSION, CURB SIDE, TRANSIT MID ROOF-FOR 32 FOOT EXTENSION LADDER
69-DDSSFTM	DDL63 EXTENSION, STREET SIDE, TRANSIT MID ROOF-FOR 32 FOOT EXTENSION LADDER
80-1LR 80-2LR	CONDUIT KITS, ALUMINUM
70-1LR 70-2LR	CONDUIT KITS, PVC
57107	DDL63 WIDE STEP LADDER KIT-ADD ON PIECE

SPECIAL APPLICATION NOTES

Introduction / Comments:

THIS DROP DOWN UNIT IS CURB SIDE, STREET SIDE SPECIFIC. THIS DROP DOWN IS FOR THE MID ROOF VEHICLE. THESE INSTRUCTIONS WILL BE SHOWING THE FORD TRANSIT FOR THE VEHICLE REPRESENTATION. THIS DROP DOWN LADDER RACK IS DESIGNED TO ADAPT TO AN ADRIAN STEEL CROSS BOW KIT FOR MID ROOF VEHICLES.

Note:

It is advised that all fasteners used in this assembly and installation of this Rack should be checked for tightness at the following intervals: @ 2-weeks and again @ 6-weeks of operation. This preventive maintenance step must be completed to ensure your package gives you long service life.

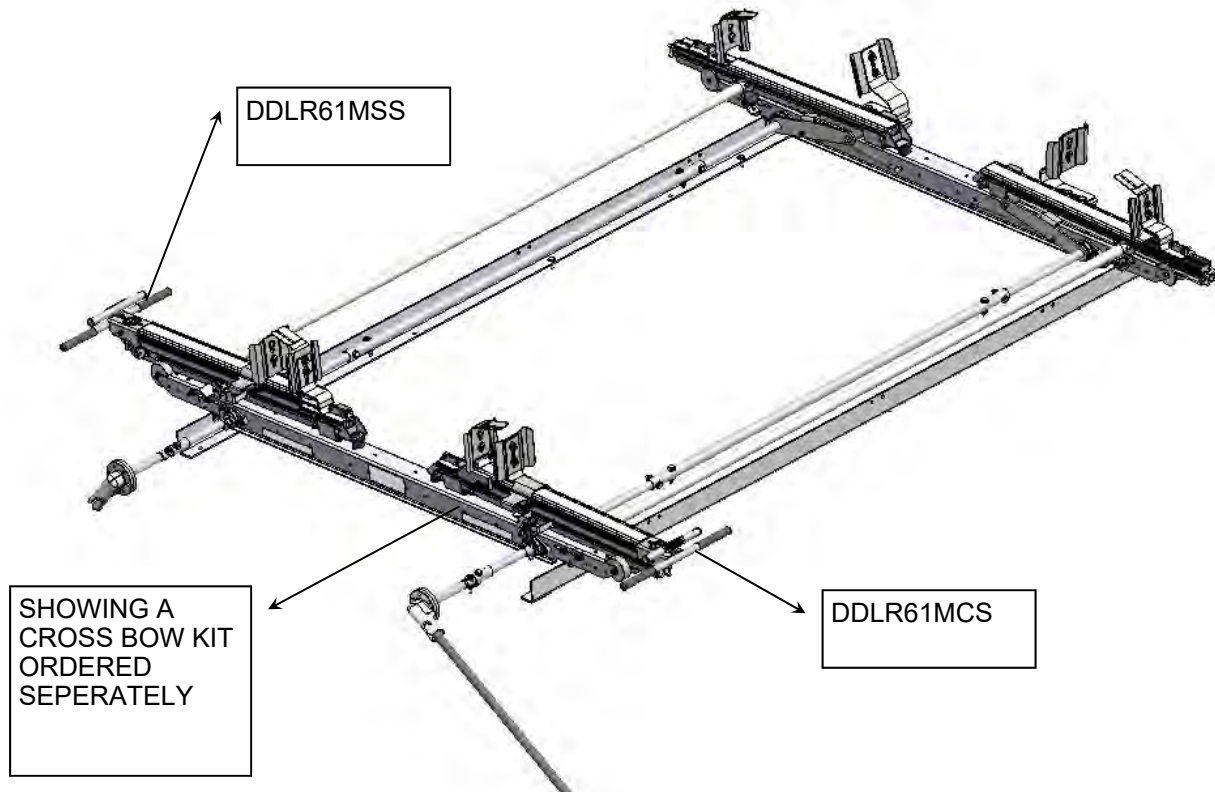

**DDL61FTM / DDL63FTM
DROP DOWN LADDER RACK, STREET, CURB
VARIOUS MID ROOF VANS**

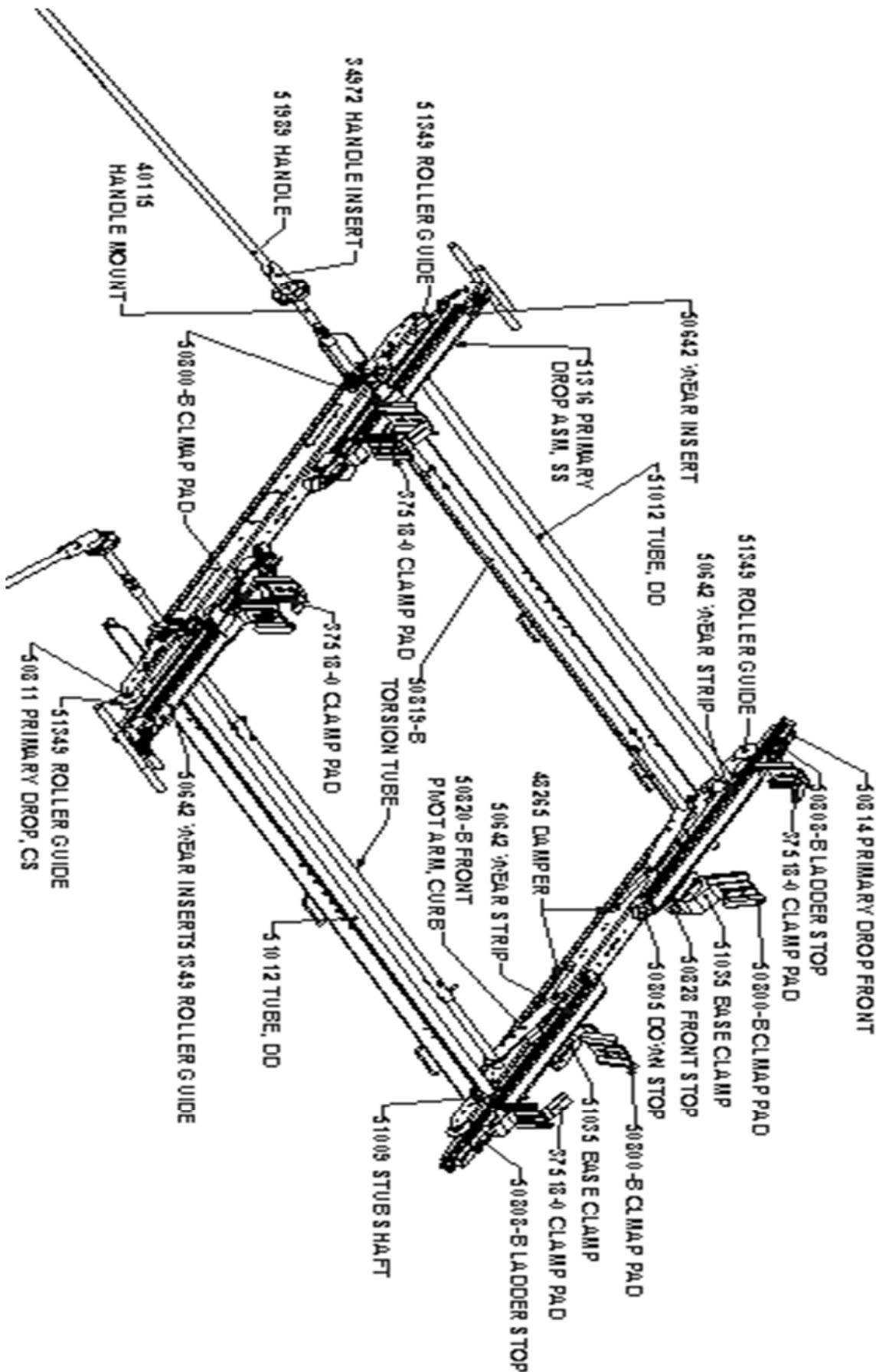

- PRECAUTIONS -





 **CAUTION** 
**THE USE OF AIR IMPACT TOOLS CAN
OVER-TORQUE FASTENERS AND
CAUSE FASTENER FAILURE!**



 **CAUTION** 
**ALL INSTALLATION HOLES SHOULD BE SEALED
WITH SILICON OR BUTYL SEALANT TO PREVENT
EXHAUST FUMES FROM ENTERING THE VEHICLE!**



 **DANGER** 
**INSPECT FOR FUEL TANK, FUEL LINES, BRAKE LINES, HIGH
VOLTAGE BATTERIES AND ELECTRICAL LINES PRIOR TO
DRILLING TO AVOID DAMAGING CRITICAL VEHICLE SYSTEMS
OR INJURY TO INSTALLER DURING INSTALLATION PROCESS!**



 **CAUTION** 
**TO AVOID DAMAGING THE VEHICLE ALWAYS
USE DRILL STOPS WHEN DRILLING ANY IN-
STALLATION HOLES!**



- IMPORTANT WARRANTY REQUIREMENTS -

1. SUBSTITUTING ADRIAN STEEL SPECIFIED FASTENERS FOR ASSEMBLY AND/OR INSTALLATION WILL VOID YOUR PRODUCT WARRANTY.
2. ALL HOLES DRILLED INTO VEHICLE SHOULD HAVE THE RAW METAL EDGES SEALED WITH A SELF-ETCHING PRIMER TO RESIST CORROSION AND POTENTIAL FASTENER POINT FAILURE.
3. ALL FASTENERS USED IN THE INSTALLATION OF THIS PRODUCT SHOULD BE TIGHTENED TO THE TORQUE(S) SPECIFIED IN THESE INSTRUCTIONS.
4. THESE INSTRUCTIONS SHOULD BE KEPT WITH THE VEHICLE.

THE BASIC TOOLS NEEDED FOR MOST INSTALLATIONS



DRILL



DRILL BIT WITH
STOP



RATCHET, SOCKETS
AND/OR WRENCHES



SCREWDRIVERS



MEASURING TAPE

ADDITIONAL TOOLS MAY BE NEEDED FOR THIS INSTALLATION AND THEY WILL BE IDENTIFIED IN THE STEPS THAT FOLLOW.

BAG52105 - DROP DOWN ASSEMBLY BAG, MID ROOF

ITEM NO.	PART NUMBER	DESCRIPTION	QTY.
1	BAG0507-A	5" x 7" 3MIL AUTOBAG	1
2	FAS0248	Nut, Nylon Insert Lock, 5/16-18 SST	34
3	34927-0	Ball Stud, Damper	4
4	34924-0	Neoprene Bumper	4
5	FAS0552	Washer, Flat, 5/16, SST	23
6	FAS0830	Screw, Hex Hd, 5/16-18 X 1.25 SS	10
7	FAS0799	Screw, Hex Hd, 5/16-18x0.75 SS	8
8	FAS0179	Screw, Hex Hd, 5/16-18x2.00 STAINLESS STEEL	6
9	FAS0811	SCREW,CAP, 5/16-18X3.50 SS	2
10	26618-0	Silicone Sealant	1
11	34928-0	Clip, Suspa P/N P68-00019	4
12	05586-0	Butyl Tape, T224 -1/2"X 1' Roll	1
13	34921-0	CLAMP, CABLE, LOOP, 1.5" ID	1
14	34922-0	TOOL HOLDER	1
15	FAS0674	SCREW, BHCS 10-24 X .75 SS	2
16	FAS0554	NUT , NYLON LOCK, #10-24, SS	2

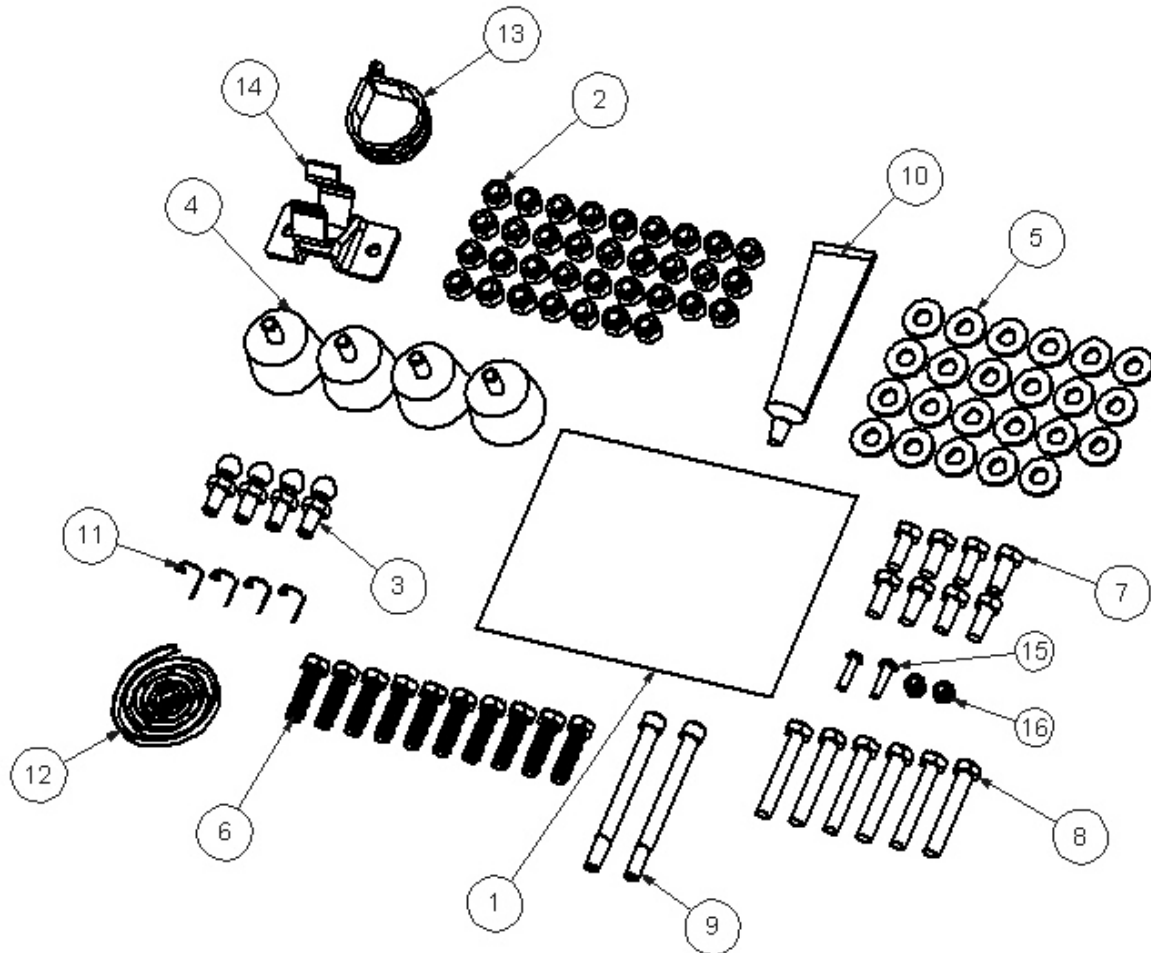

BAG51041—FINAL ASSEMBLY FASTENER BAG

ITEM NO.	PART NUMBER	DESCRIPTION	QTY.
1	BAG0507-A	5" x 7" 3MIL AUTOBAG	1
2	FAS0246	Washer, Flat, 3/8, HRD, ZN	6
3	FAS0799	Screw, Hex Hd, 5/16-18x0.75 SS	4
4	FAS0110	Nut,Hex Nylk 3/8-16 SS W	4
5	FAS0572	Screw, Button Hd Hex Soc, 3/8-16x1.00 NI-ZN	2
6	FAS0588	Washer, Lock, Split, 5/16, SS	4
7	FAS0286	SCREW, HHCS, 3/8-16x4, SS	2
8	FAS0287	COTTER PIN, 1/16DIA X 1"LG, SS	2

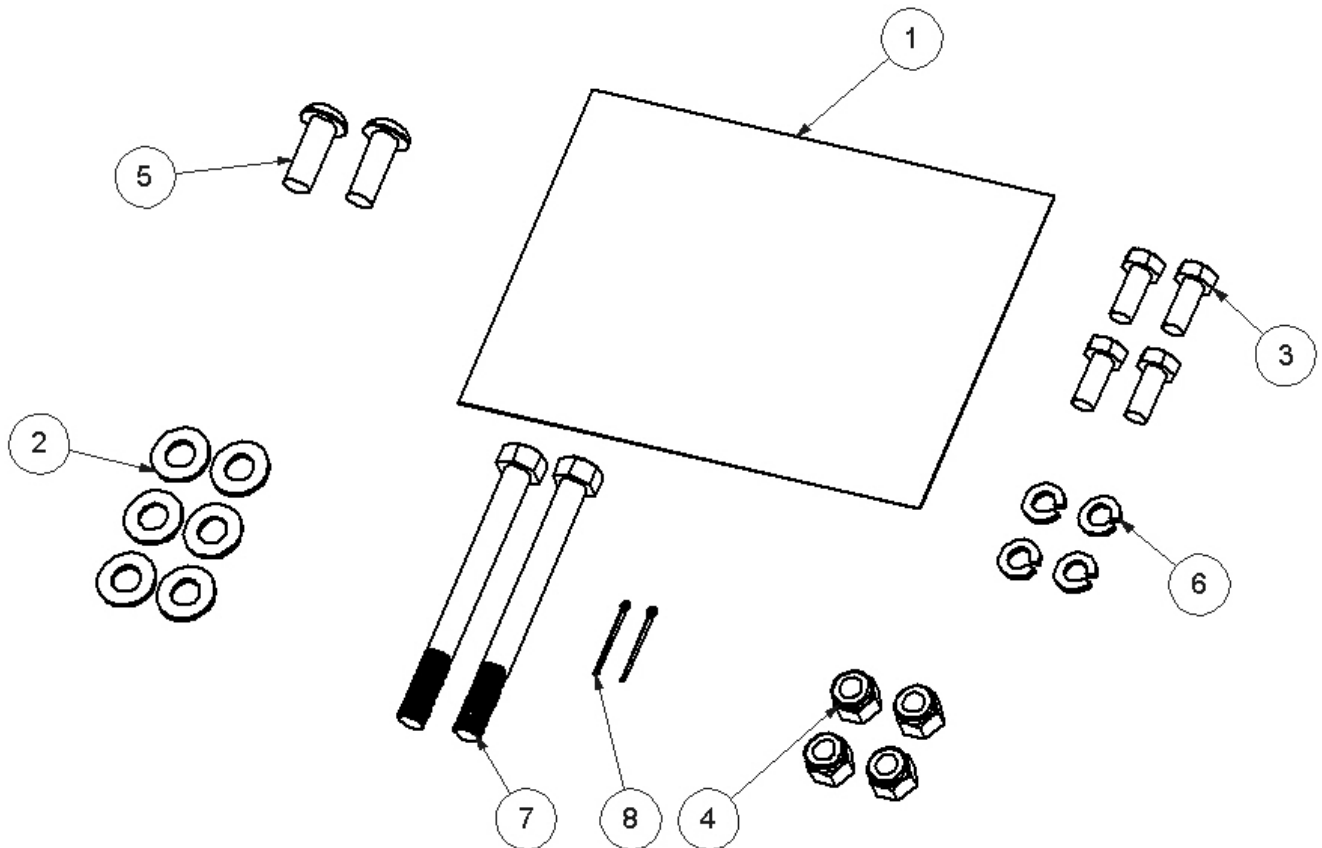

STEP #1A : ASSEMBLE CURB SIDE REAR CROSS BOW

REAR OF THE VAN

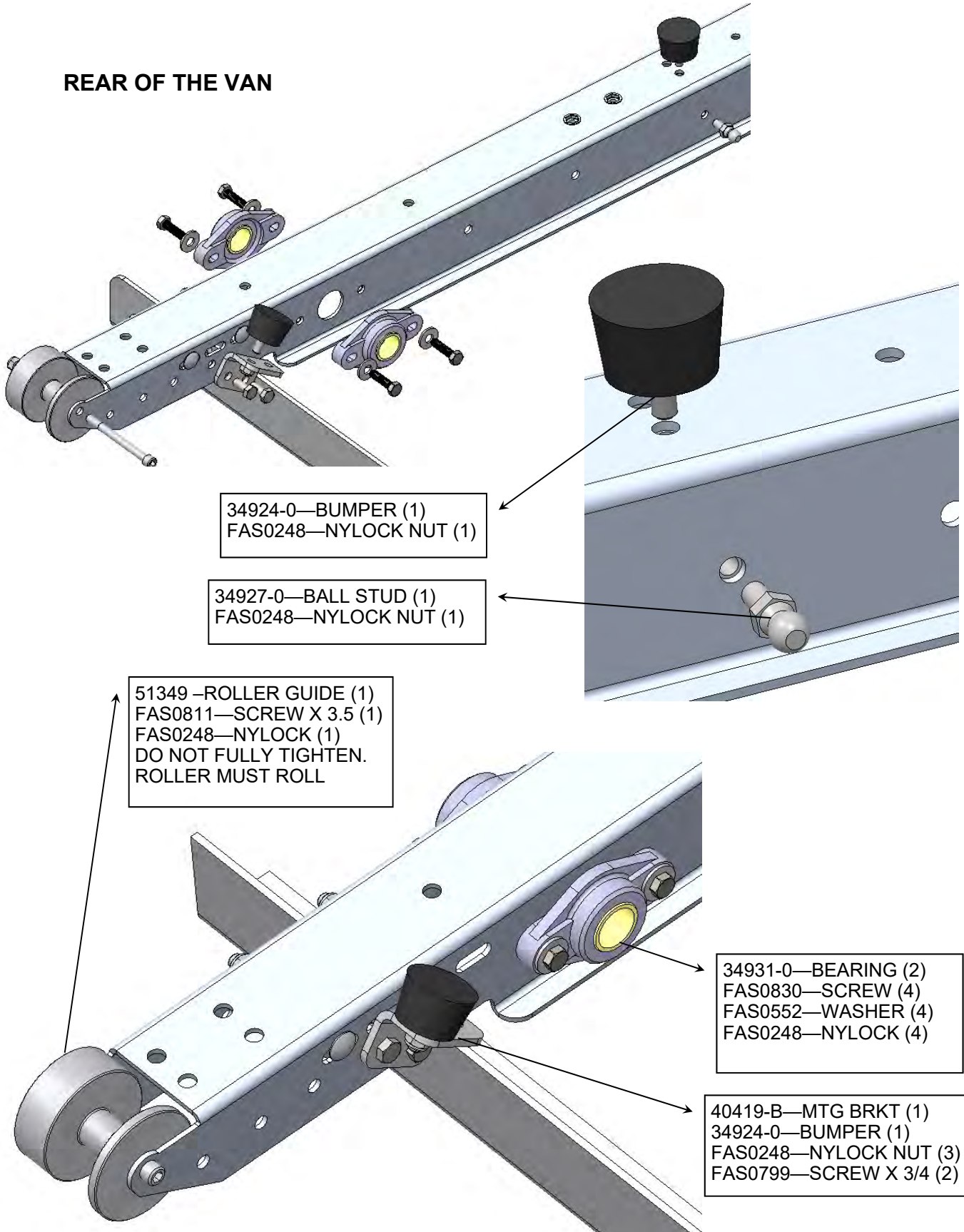

34924-0—BUMPER (1)
FAS0248—NYLOCK NUT (1)

34927-0—BALL STUD (1)
FAS0248—NYLOCK NUT (1)

51349—ROLLER GUIDE (1)
FAS0811—SCREW X 3.5 (1)
FAS0248—NYLOCK (1)
DO NOT FULLY TIGHTEN.
ROLLER MUST ROLL

34931-0—BEARING (2)
FAS0830—SCREW (4)
FAS0552—WASHER (4)
FAS0248—NYLOCK (4)

40419-B—MTG BRKT (1)
34924-0—BUMPER (1)
FAS0248—NYLOCK NUT (3)
FAS0799—SCREW X 3/4 (2)



STEP #2A : ASSEMBLE CURB SIDE FRONT CROSS BOW. DO NOT ATTACH TO THE RAIL YET.

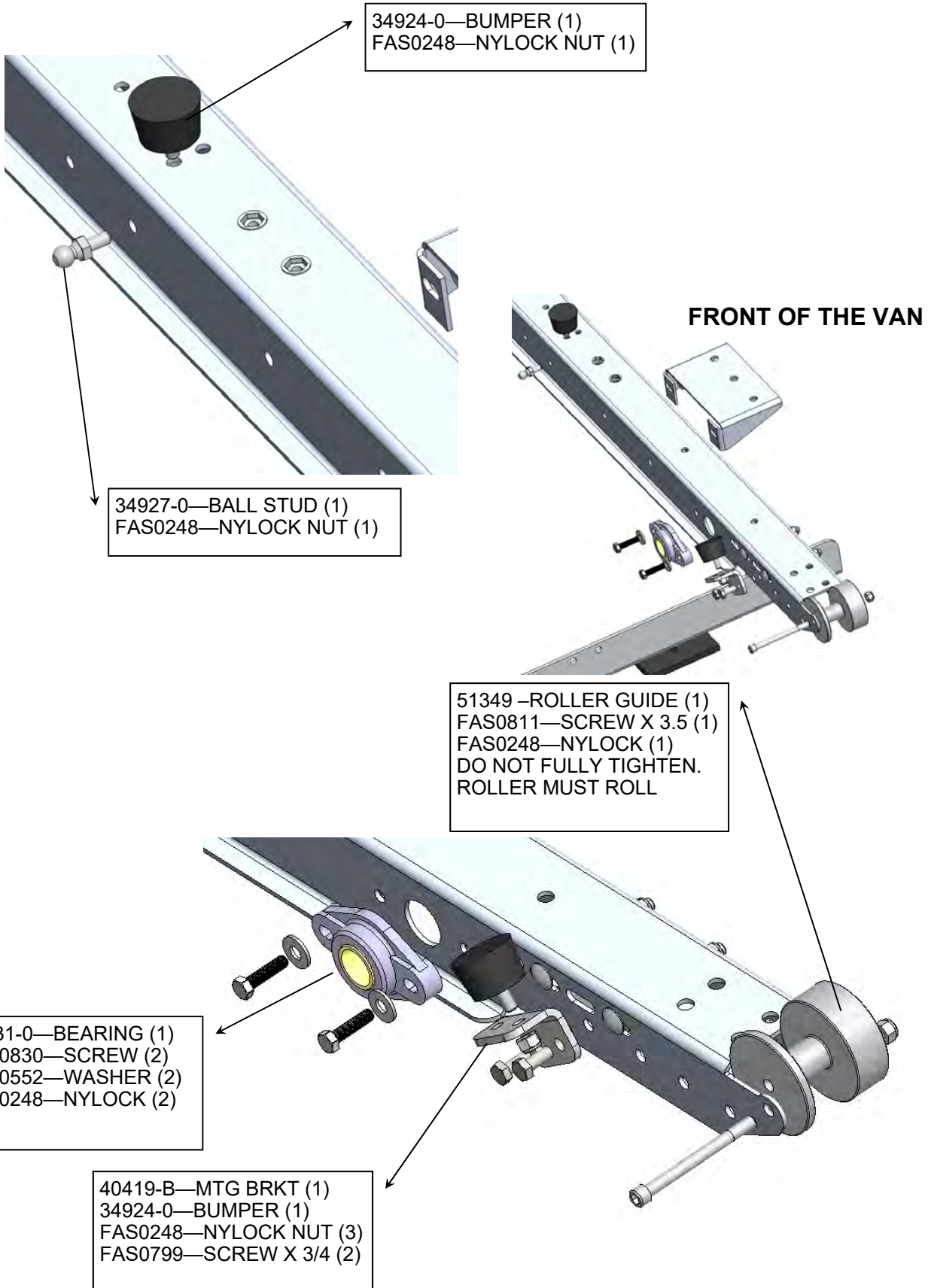



STEP #2B : ASSEMBLE CURB SIDE FRONT CROSS BOW. DO NOT ATTACH TO THE RAIL YET.

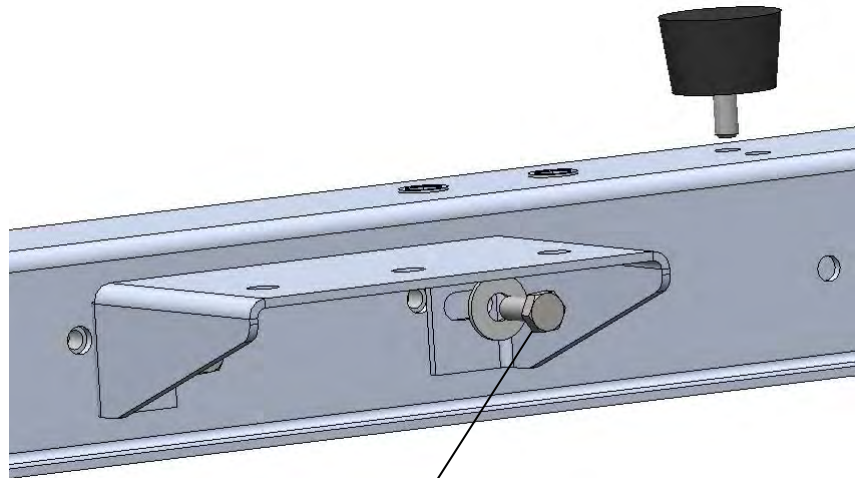
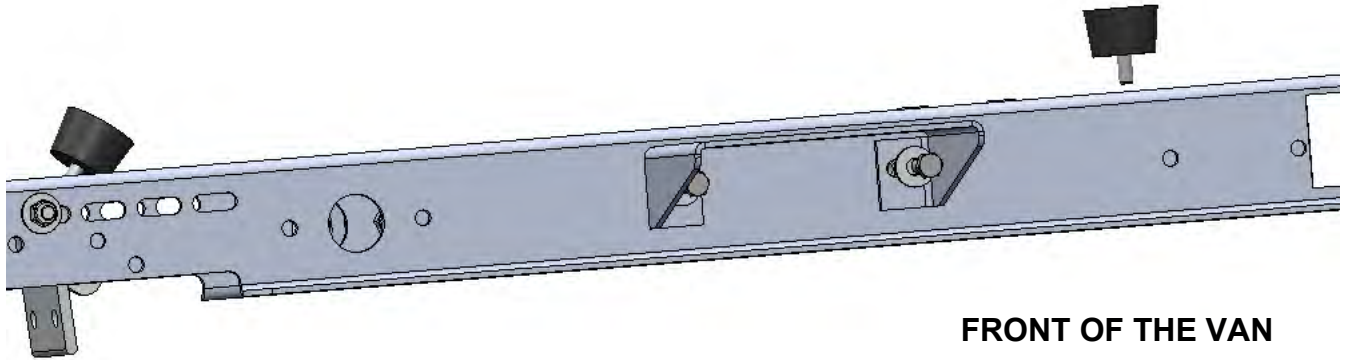

STEP #3A : ASSEMBLE CURB SIDE PIVOT DRIVE TO THE CROSS BOWS

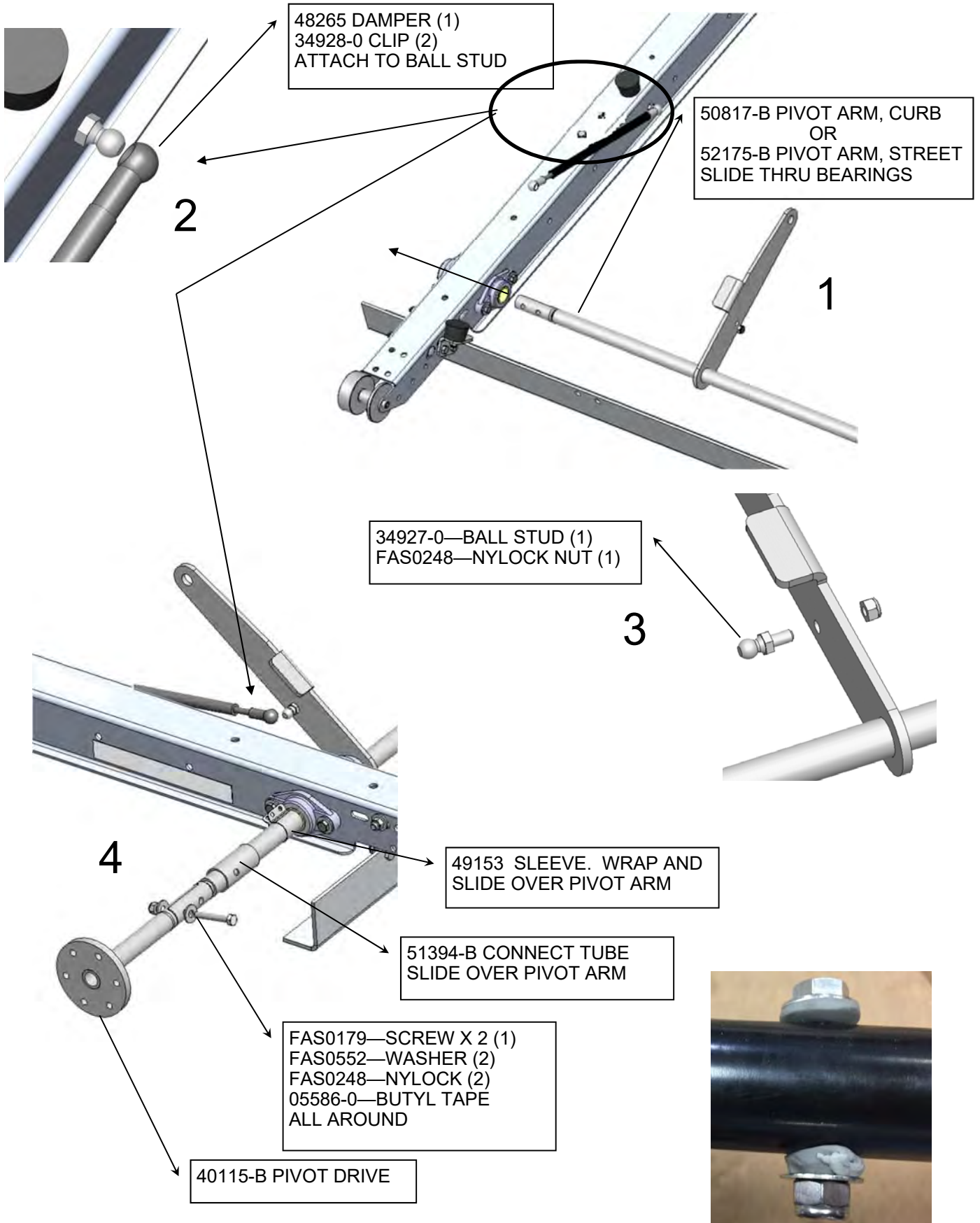

STEP #3B : ASSEMBLE CURB SIDE PIVOT DRIVE TO THE CROSS BOWS

SLIDE TUBE DOWN
FAS0179—SCREW X 2 (1)
FAS0552—WASHER (2)
FAS0248—NYLOCK (2)
05586-0—BUTYL TAPE
ALL AROUND

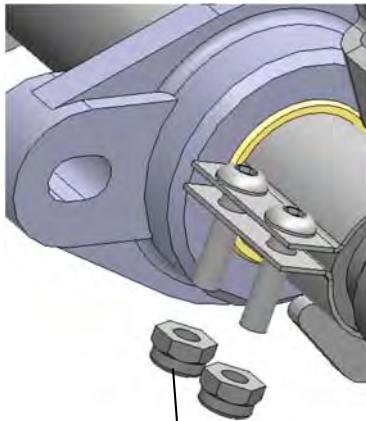
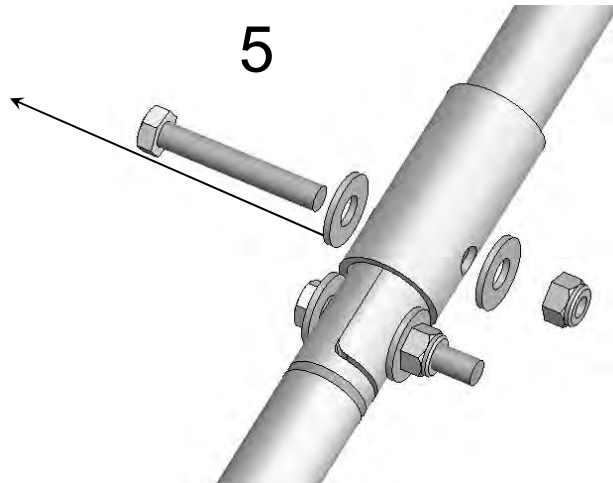

SCREWS MUST BE ON THIS SIDE !!
FAS0674—SCREW X 3/4 (2)
FAS0554—NUT (2)

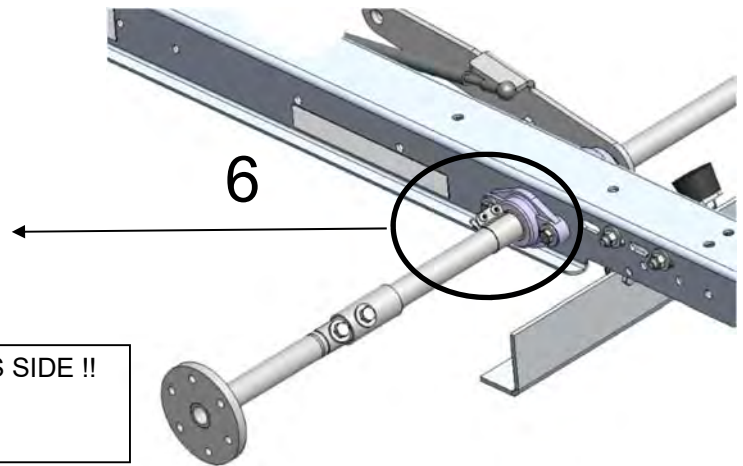

CHECK ORIENTATION
FAS0830—SCREW (3)
FAS0248—NYLOCK (3)

34972-0—HANDLE JUNCTION

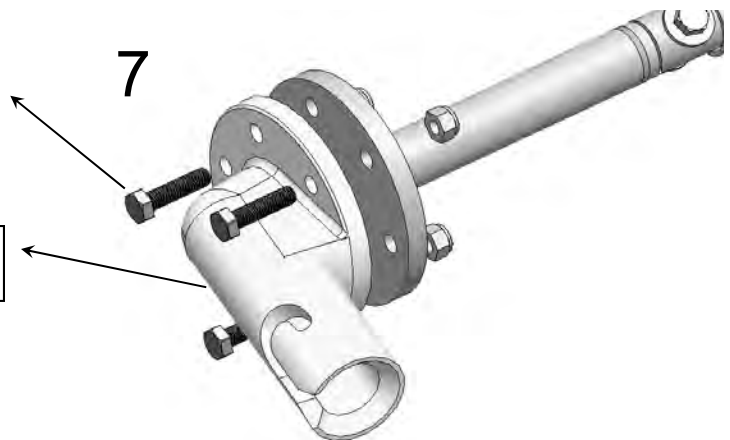

STREET SIDE

CURB SIDE



STEP #4A : ASSEMBLE CURB SIDE PIVOT DRIVE AT REAR OF VEHICLE.

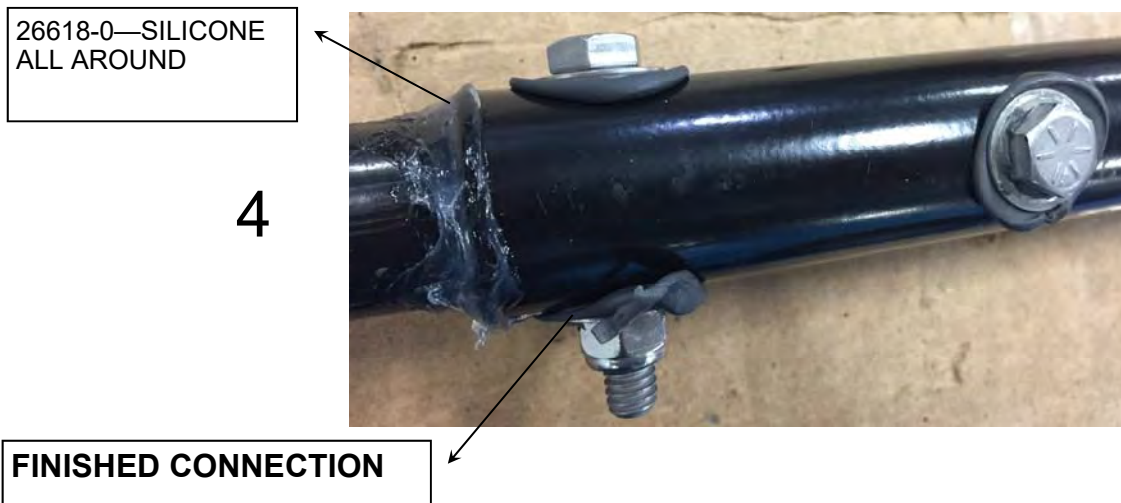
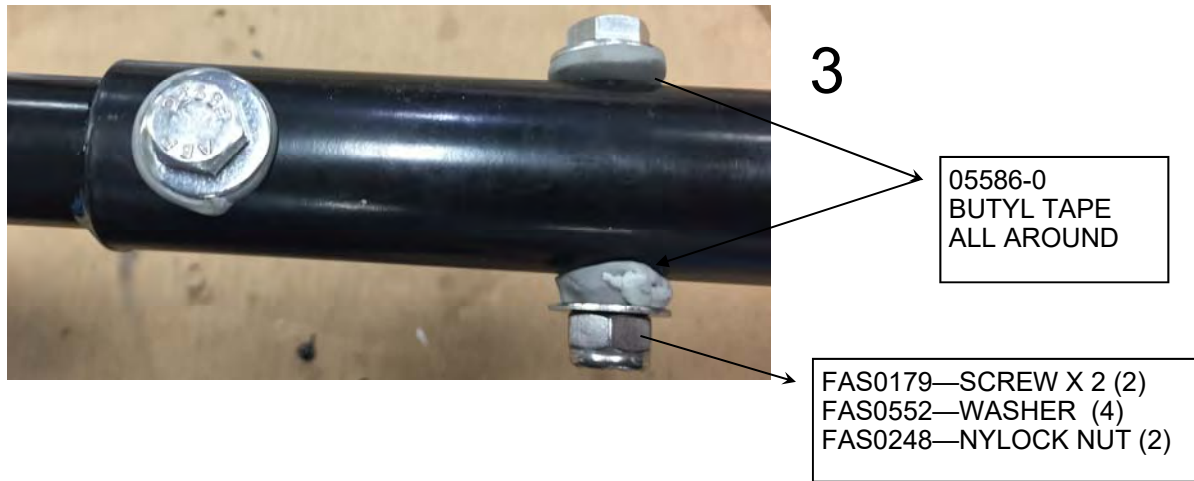
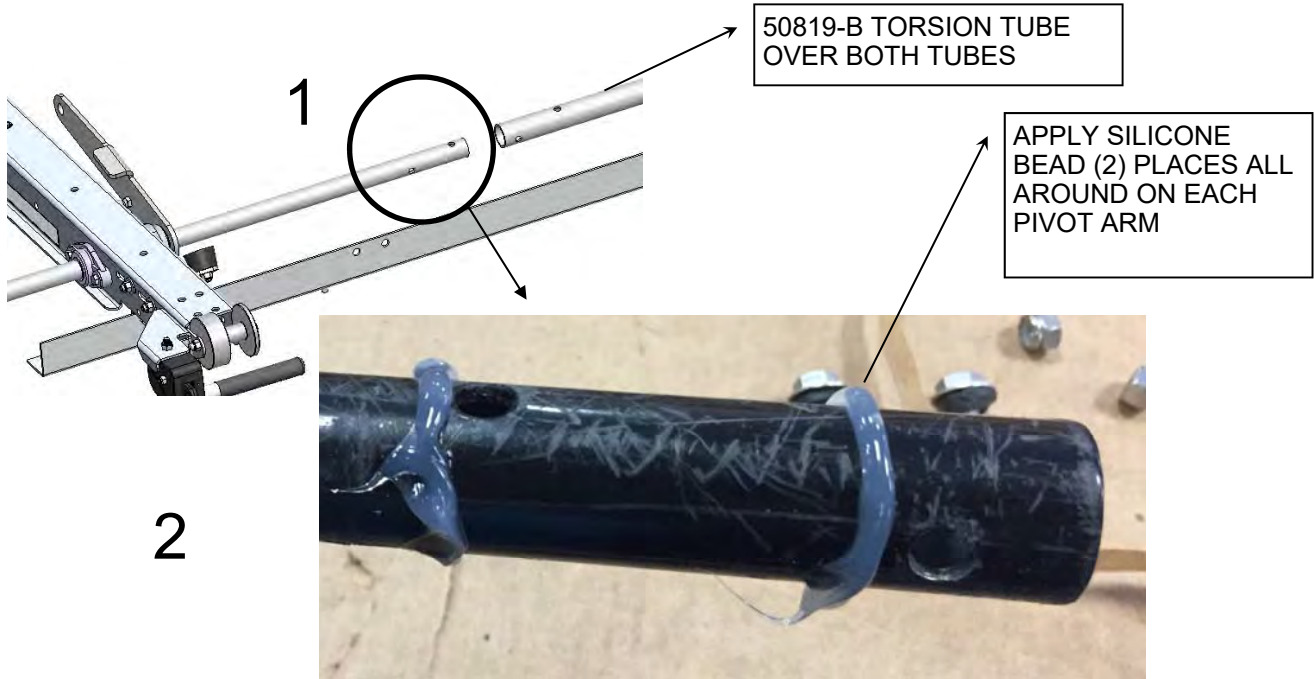

STEP #4B : ASSEMBLE CURB SIDE PIVOT DRIVE AT FRONT OF VEHICLE

APPLY SILICONE BEAD (2) PLACES ALL AROUND ON EACH PIVOT ARM

5

50817-B—PIVOT ARM, CS



6



7

05586-0 BUTYL TAPE ALL AROUND

FAS0179—SCREW X 2 (4)
FAS0552—WASHER (8)
FAS0248—NYLOCK NUT (4)

26618-0—SIL1CONE ALL AROUND

8



FINISHED CONNECTION

STEP #4C : ASSEMBLE CURB SIDE PIVOT DRIVE TO THE CROSS BOWS

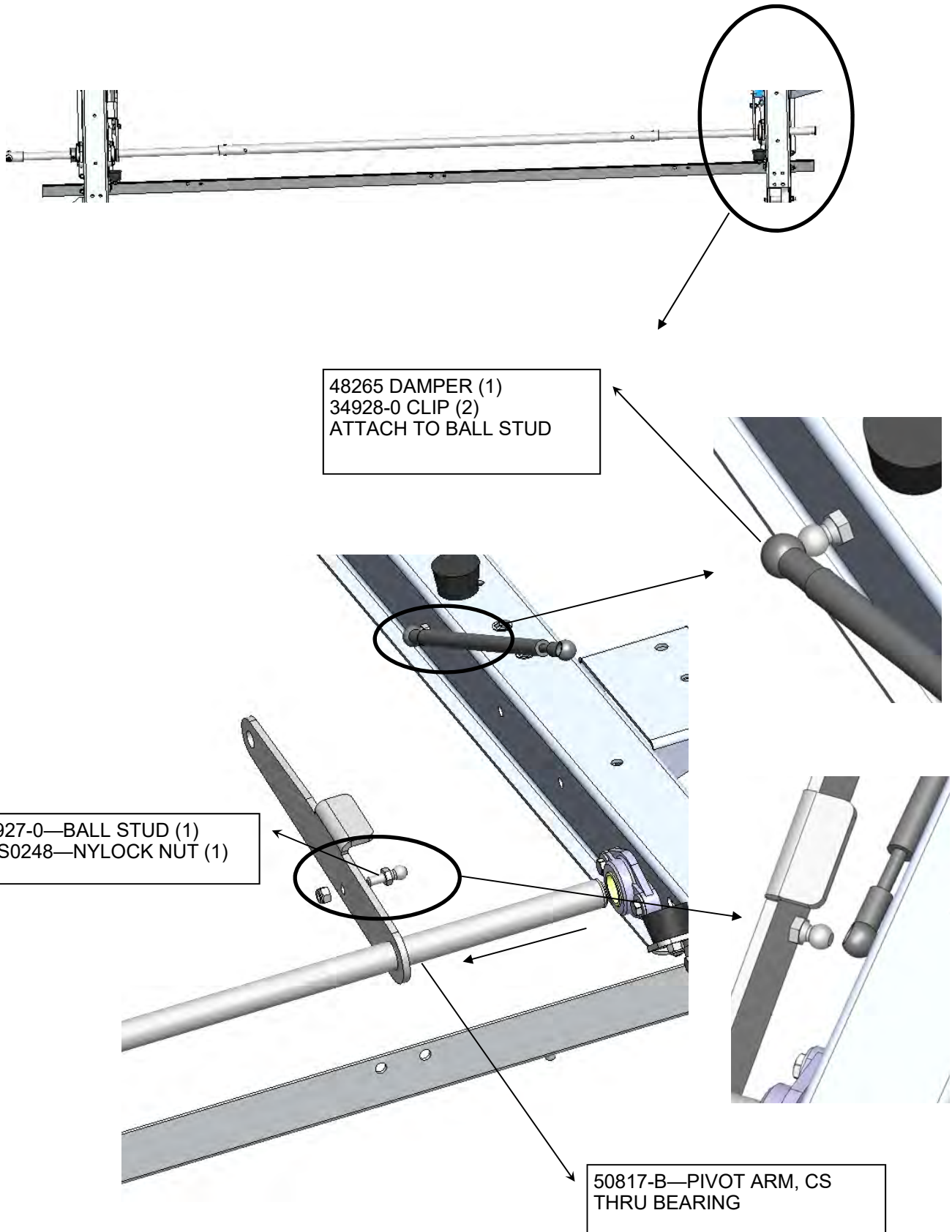

STEP #5A : CHECK WHAT YOU ARE BUILDING

- CONTINUE TO STEP #6 FOR A CURB SIDE ONLY INSTALL
- REPEAT STEPS 1 THRU 4 FOR THE STREET SIDE PIVOT DRIVE USING 52175-B PIVOT ARM, STREET IN PLACE OF 50817-B PIVOT ARM, CURB.

THIS IS THE SHIP THRU FINAL SINGLE DROP DOWN

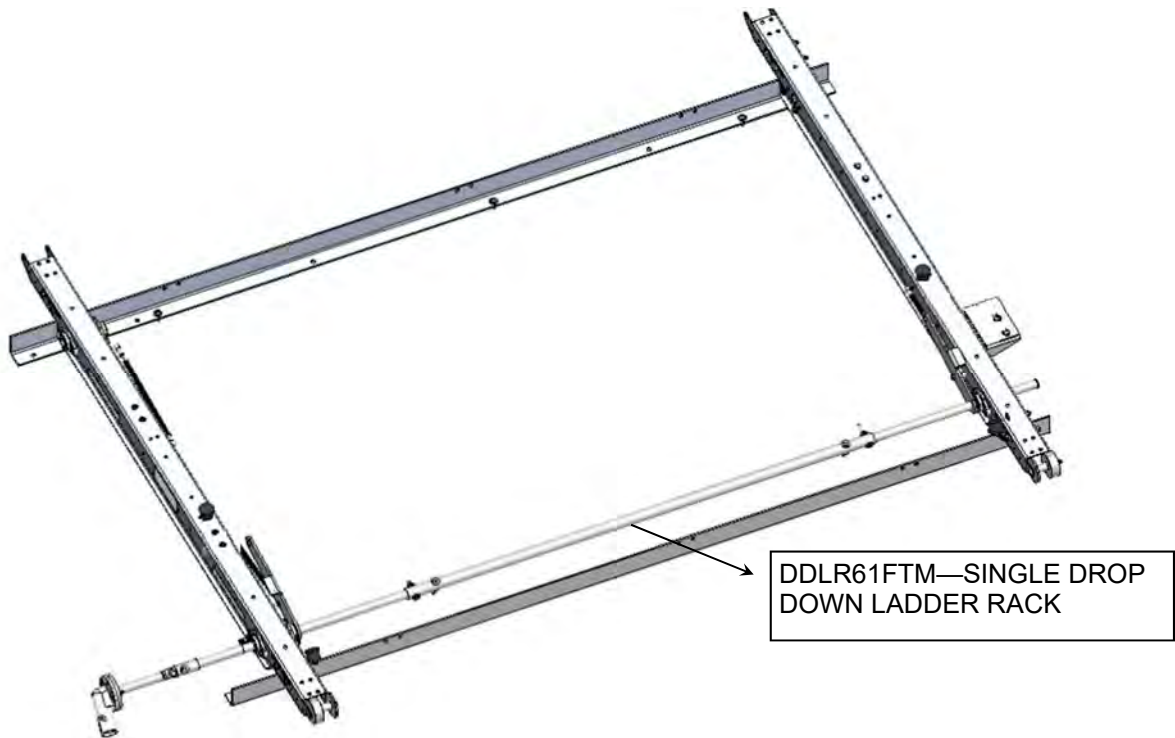

THIS IS THE SHIP THRU FINAL DOUBLE DROP DOWN

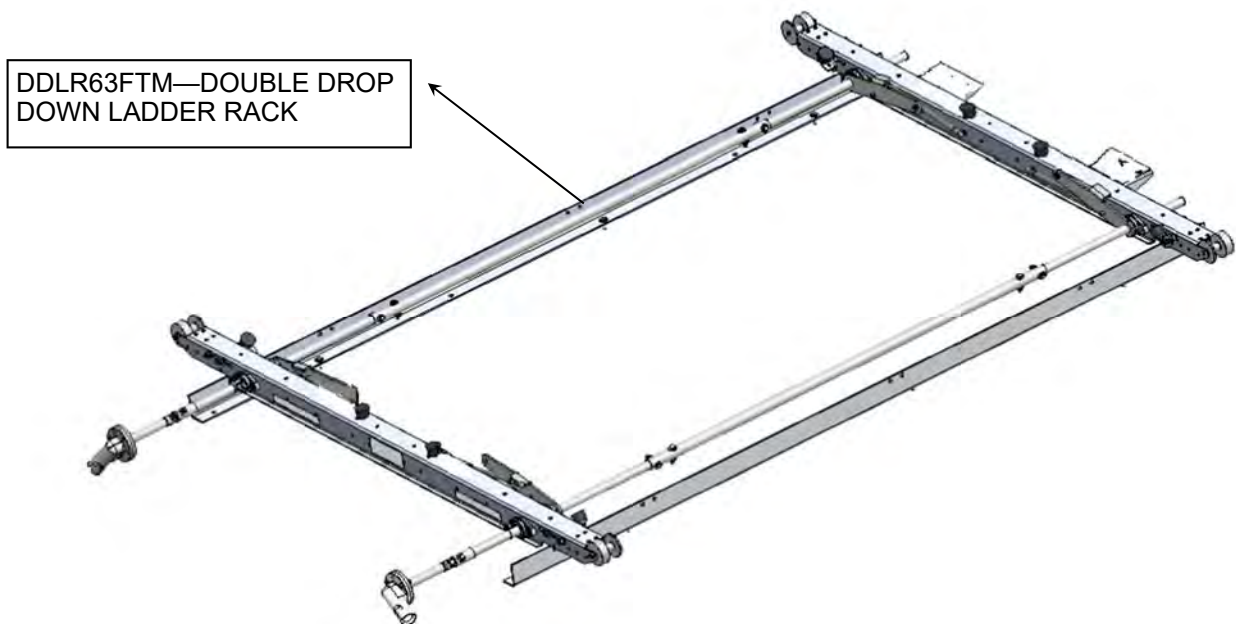

STEP #5B : THIS IS THE SHIPTHRU FINAL—SHOWING SINGLE AND DOUBLE AS YOU WOULD RECEIVE FOR FINAL DEALER ASSEMBLY.

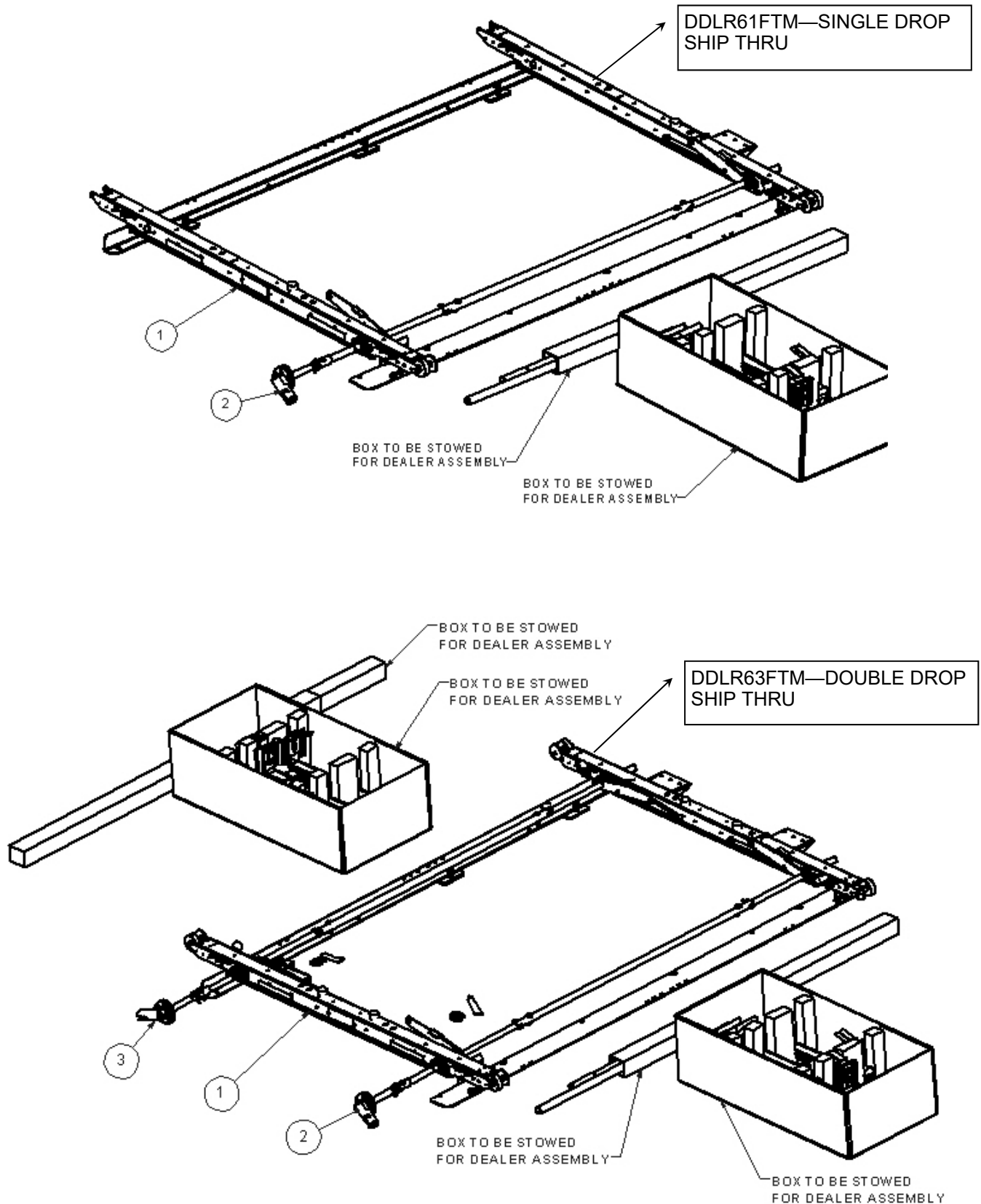

STEP #6 - FINAL ASSEMBLY, SHOWING THE CURB AND STREET SIDE DROP DOWN COMPONENTS

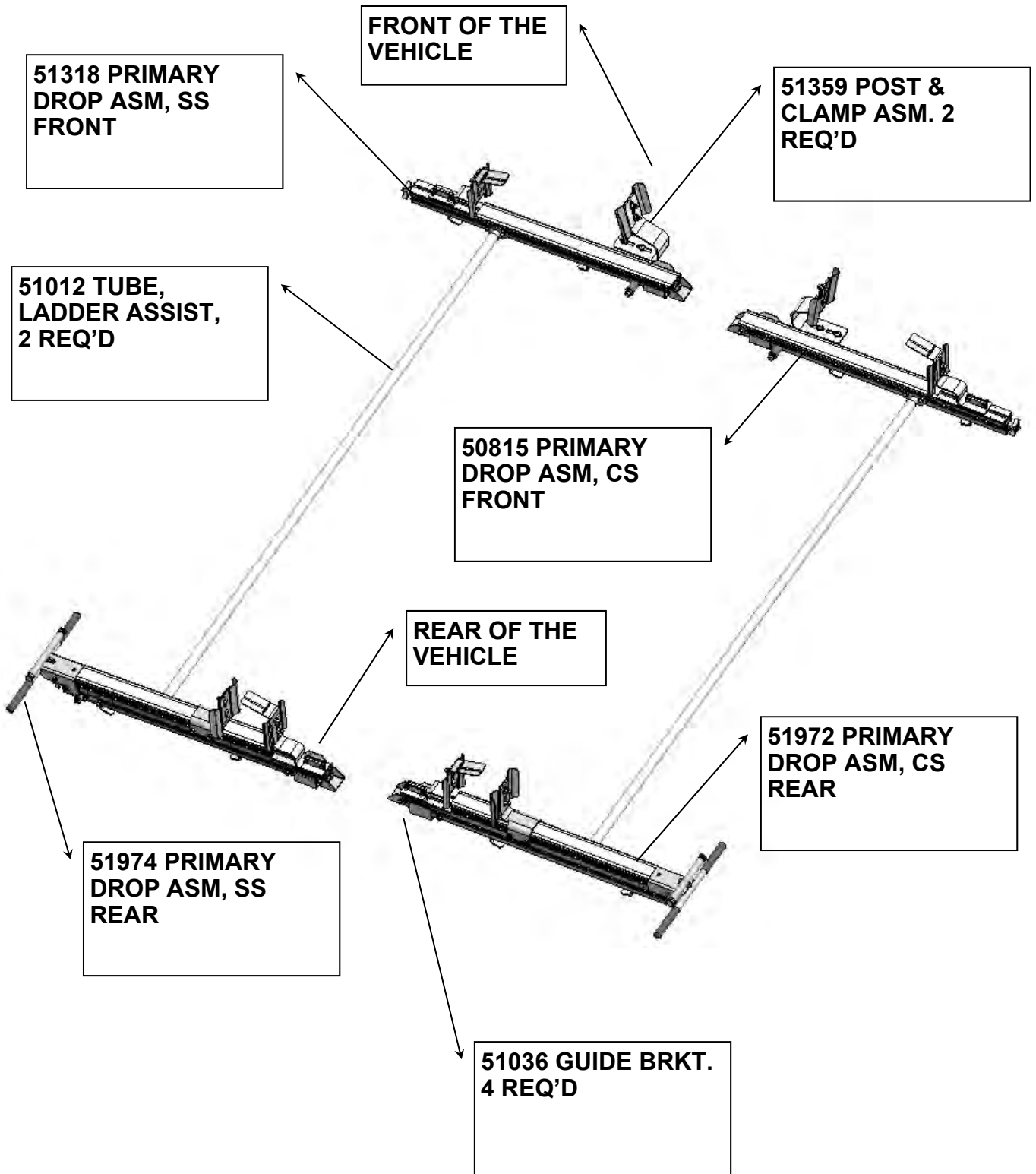

STEP #7- ASSEMBLE BRACKETS TO THE FRONT AND REAR CROSS BOWS

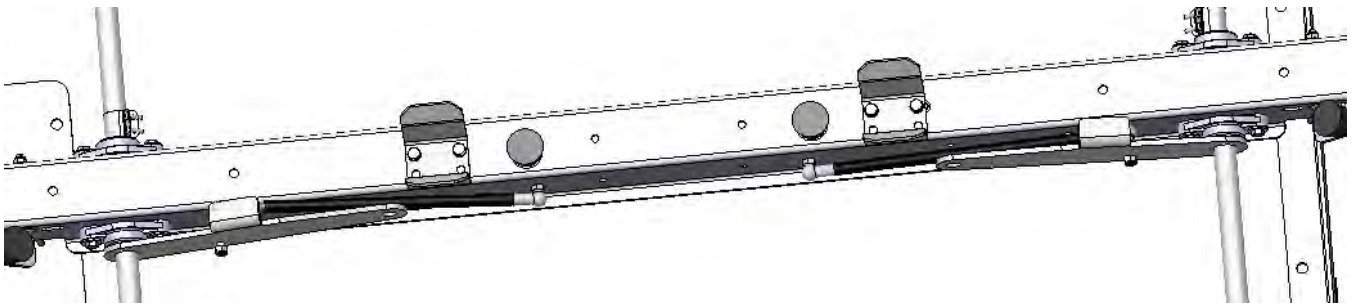

STEP 7 : COMPLETED VIEW OF THE REAR CROSS BOW

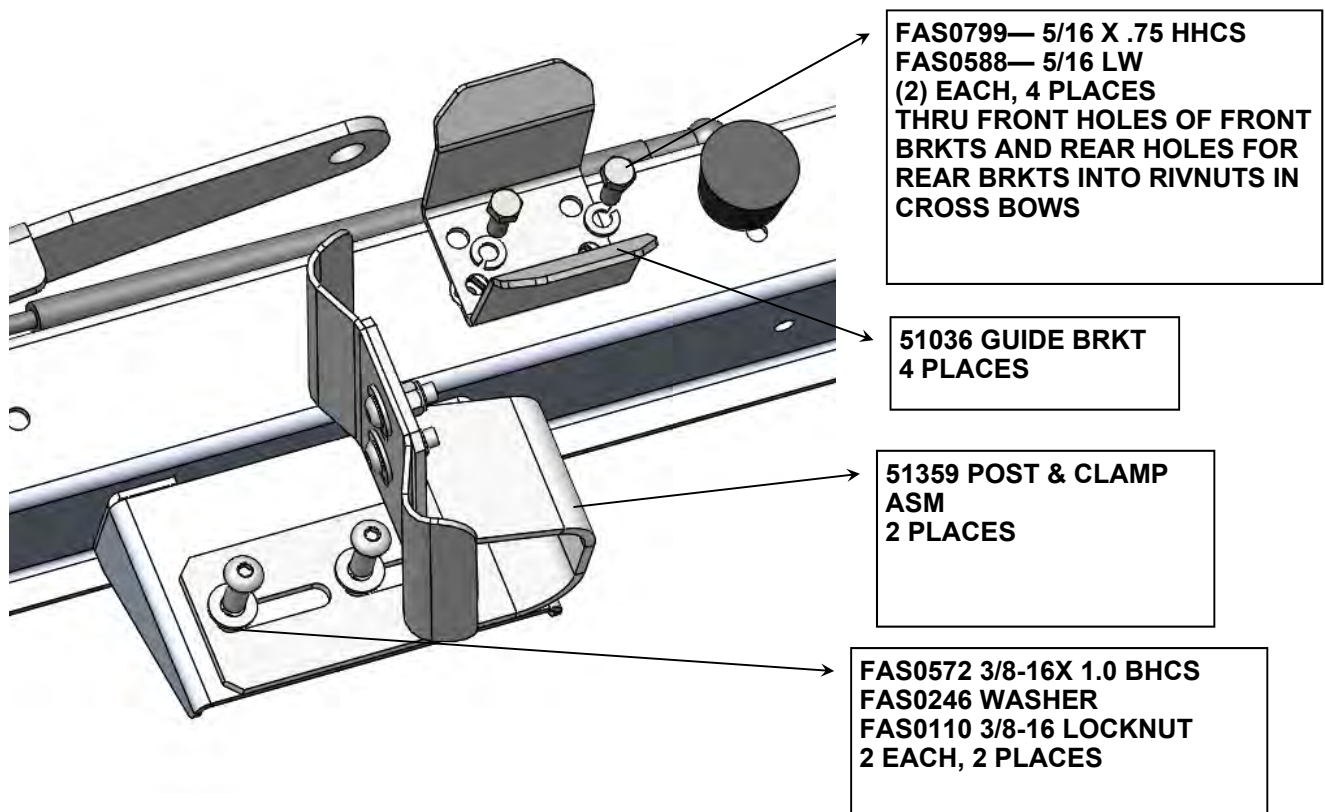

STEP 7 : COMPLETED VIEW OF THE FRONT CROSS BOW

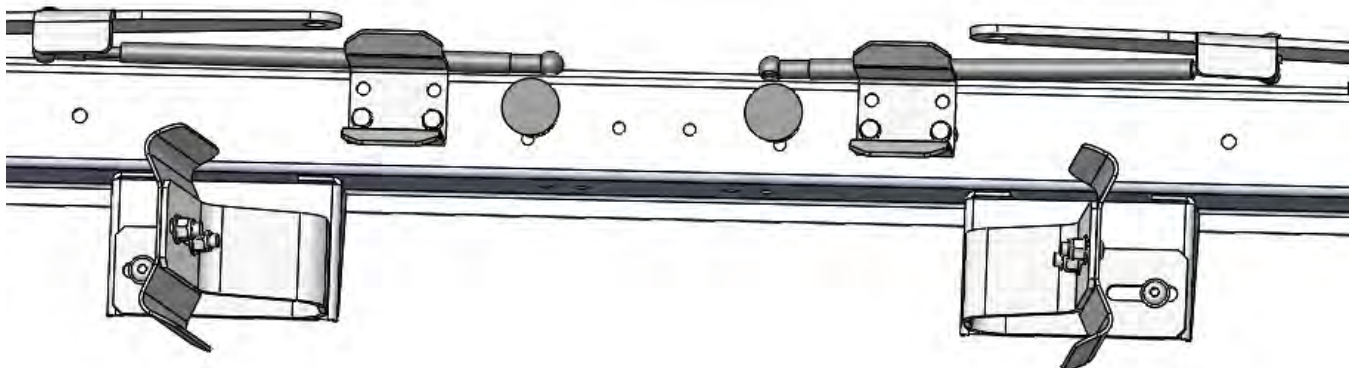

STEP 8 : ASSEMBLE REAR CURB SIDE PRIMARY DROP TO CROSS BOW

**SET 51972 PRIMARY DROP ASM, REAR CS IN PLACE ON REAR CROSS BOW.
USE GUIDE ROLLER**

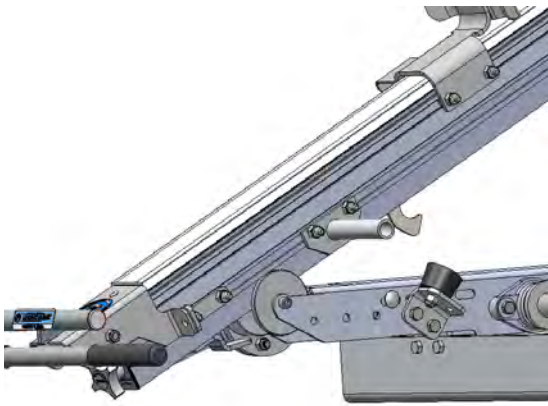

**51972 PRIMARY DROP
ASM CS REAR**

**51972 PRIMARY DROP
ASM, CS REAR**

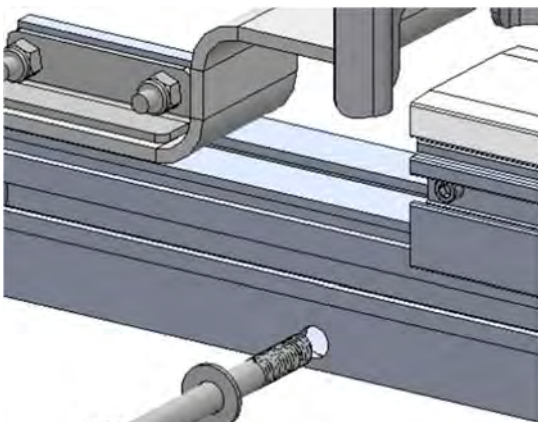
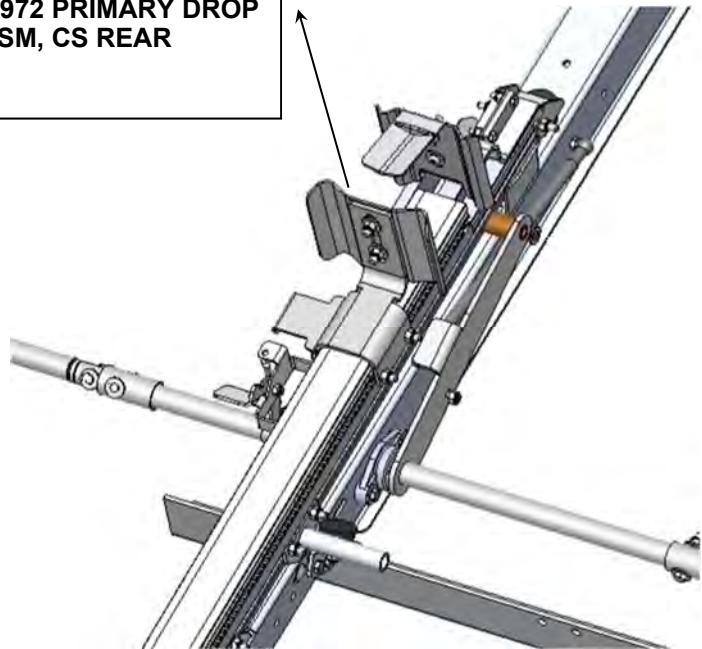

**FAS02826 3/8-16 X 4" HHCS
FAS0246 WASHER**

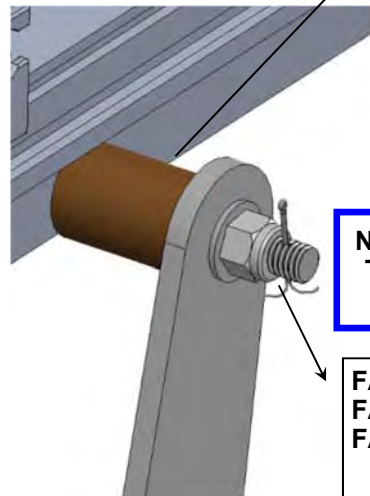

**51034 BRONZE
BUSHING**

**NOTE: TORQUE NYLOCK NUT
TO 20FT.LBS, THEN INSERT/
SECURE THE COTTER PIN.**

**FAS0246 WASHER
FAS0110 3/8-16 NYLOCK NUT
FAS0287—COTTER PIN**

**NOTE: AFTER THE COTTER
PIN IS INSERTED THROUGH
THE BOLT, SPREAD THE PIN
SO IT CAN NOT BE REMOVED.**

STEP 9: ASSEMBLE FRONT SIDE PRIMARY DROP TO RACK

SET 50815 PRIMARY DROP ASM, FRONT CS IN PLACE ON FRONT CROSS BOW. USE GUIDE ROLLER AFTER LADDER ASSIST TUBE IS ON BOTH STUB SHAFTS

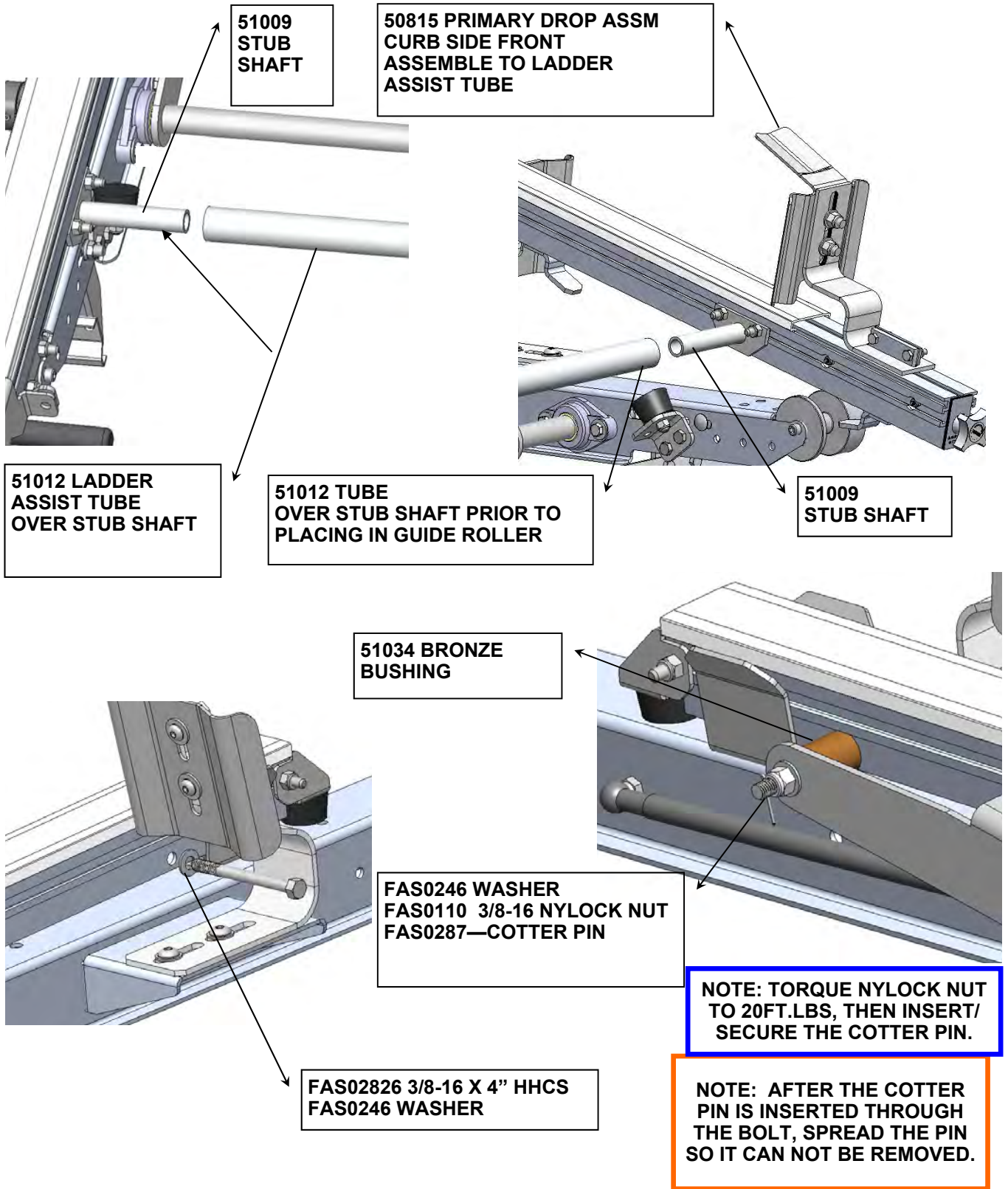

STEP #10 : ADJUST THE HIGH WIND LATCH TO YOUR VEHICLE

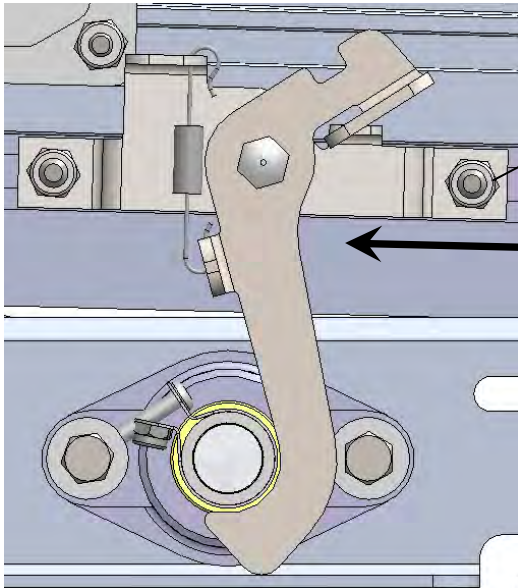

LOOSEN HEX NUTS WITH 1/2" WRENCH. ADJUST TO POSITION SHOWN AND TEST. ADJUST UNTIL LATCH IS WORKING PROPERLY AT NUMBER 5

1

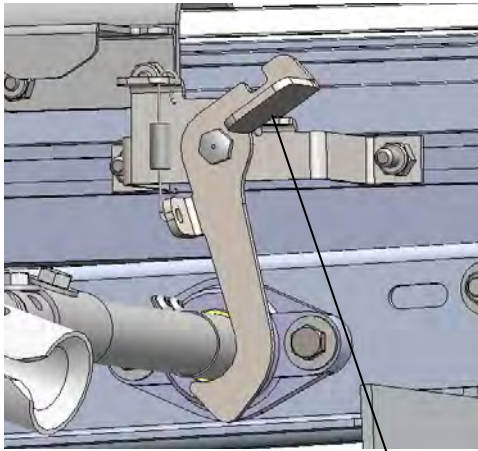

2

PUSH TO OPEN LATCH

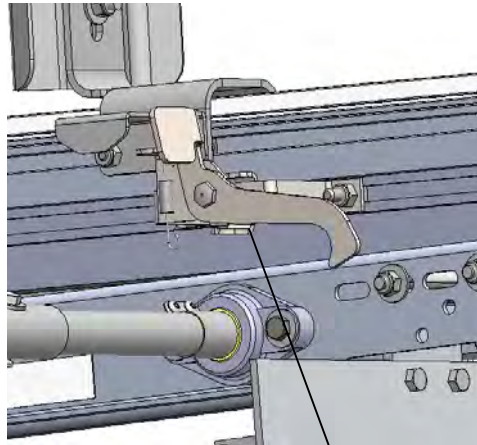

3

OPENED LATCH

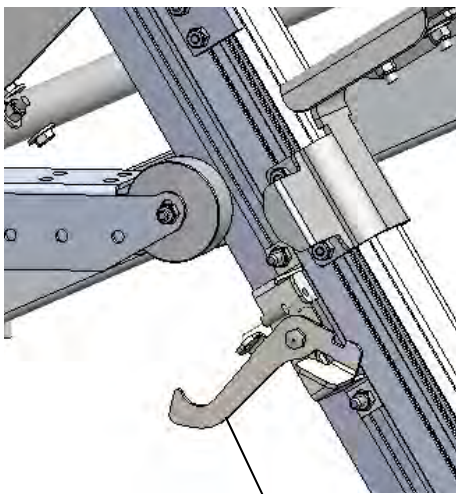

4

PIVOT DROP DOWN CLOSE LATCH

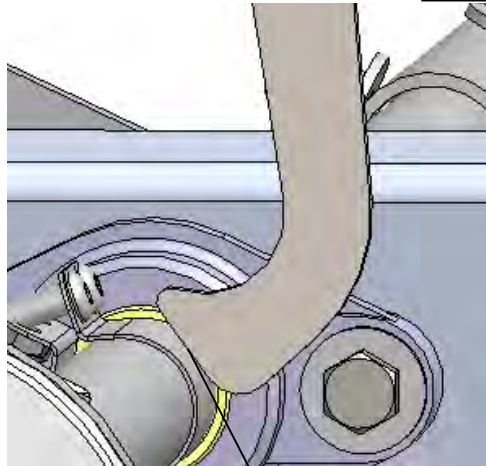

5

LATCH NEEDS TO HIT LEADING EDGE OF LATCH WHEN CLOSING



STEP #11 : FOR A DOUBLE DROP DOWN, INSTALL STREET SIDE USING STEPS #7, #8, #9 & #10 AS YOUR GUIDE.

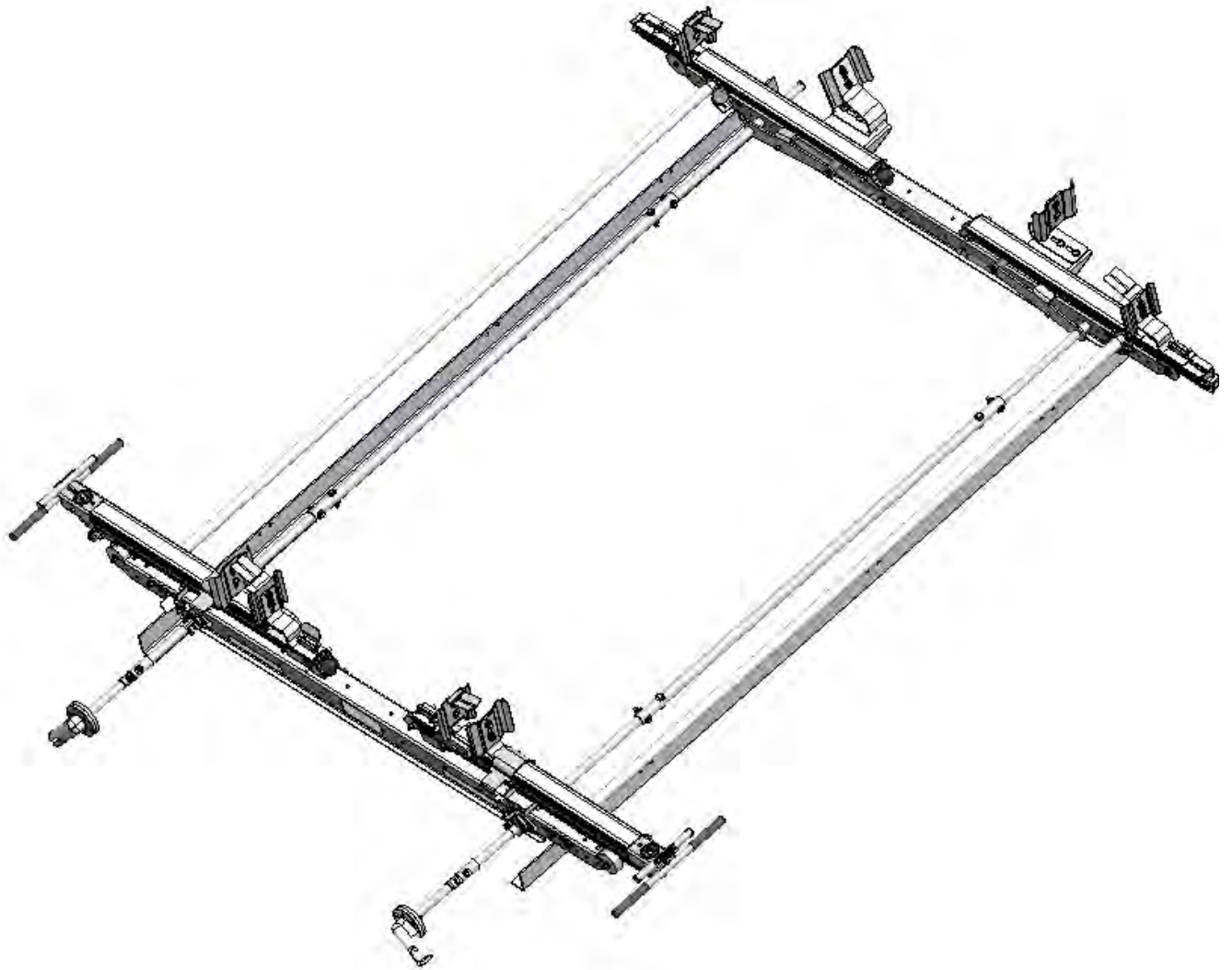

**DOUBLE CHECK ALL FASTENERS LOCATIONS TO BE SURE THAT ALL FASTENERS ARE TIGHTENED TO SPECIFICATIONS.
YOUR INSTALLATION IS NOW COMPLETE!
STOW THIS COPY IN THE VEHICLE FOR FUTURE REFERENCES!**



STEP #12 : USING THE HANDLE

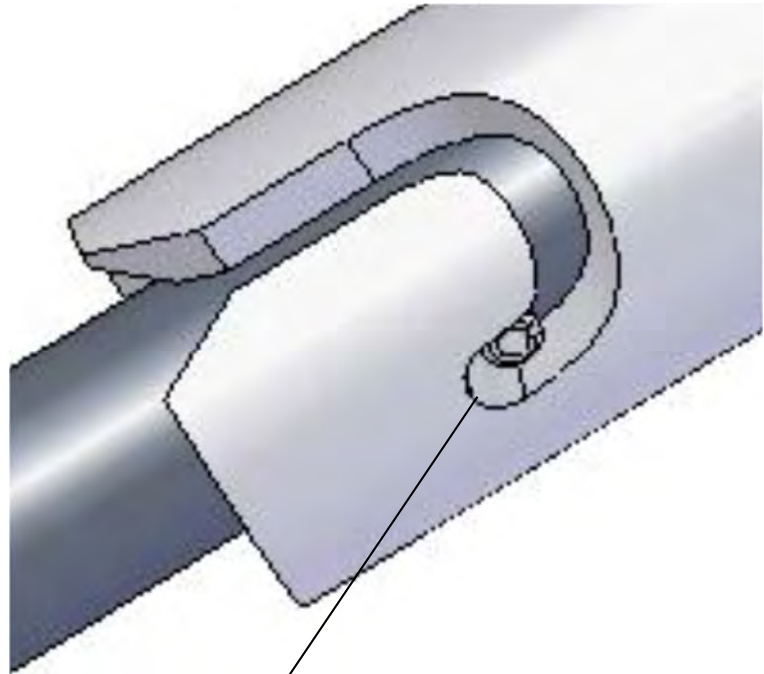
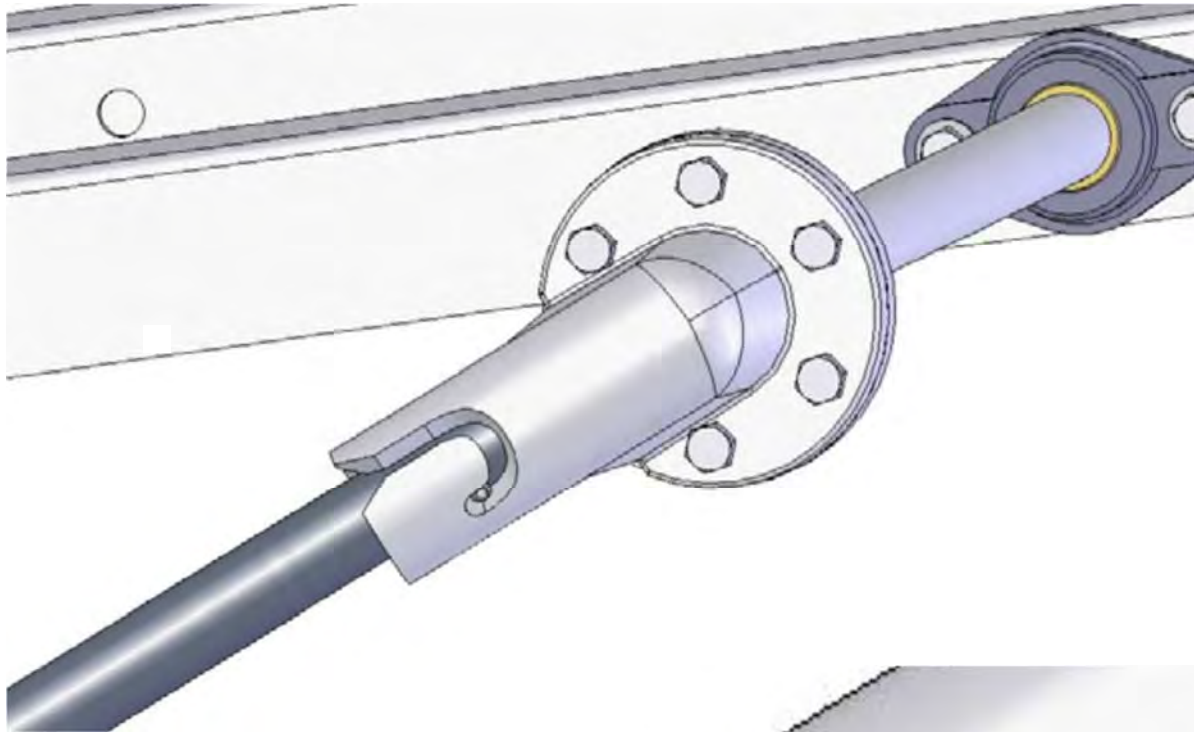

TO SECURE HANDLE INTO CASTING
ALIGN PIN WITH BOTTOM OF SLOT
IN CASTING, PUSH IN AND TWIST.

THEN PULL DOWN SO THE PIN IS IN
THE POSITION SHOWN.



STEP #13 : OPTIONAL, STOW THE PIVOT HANDLE

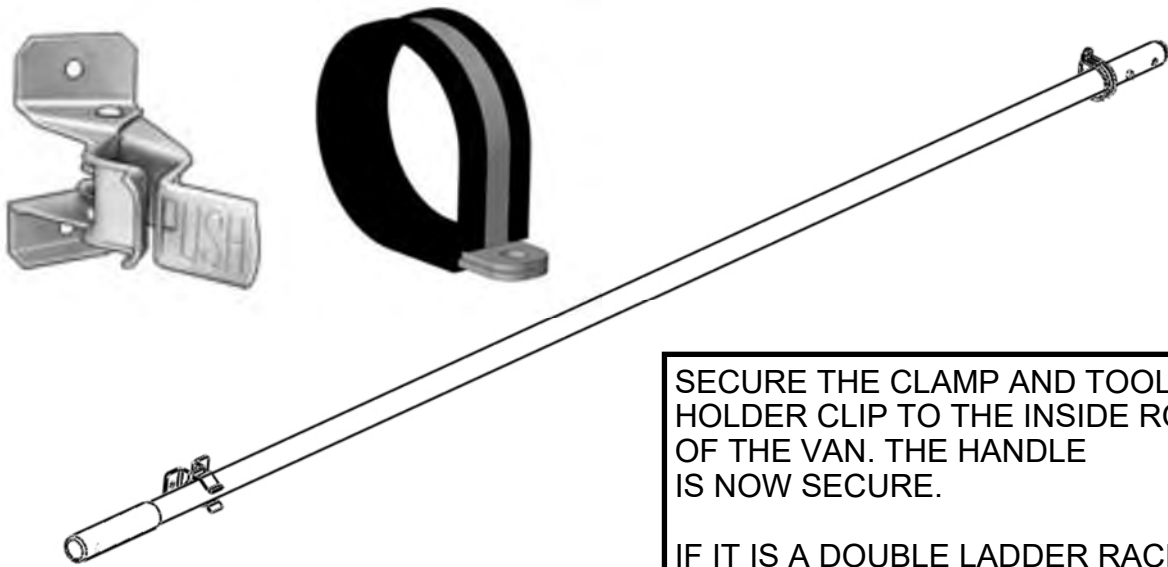

SECURE THE CLAMP AND TOOL HOLDER CLIP TO THE INSIDE ROOF OF THE VAN. THE HANDLE IS NOW SECURE.

IF IT IS A DOUBLE LADDER RACK, INSTALL A POLE ON EACH SIDE AS SHOWN.





STEP #14: YOUR DOUBLE DROP DOWN INSTALLATION IS NOW COMPLETE



**DOUBLE CHECK ALL FASTENER LOCATIONS TO BE SURE THAT ALL
FASTENERS ARE TIGHTENED TO SPECIFICATIONS.
YOUR INSTALLATION IS NOW COMPLETE!
STOW THIS COPY IN THE VEHICLE FOR FUTURE REFERENCES!**

**REAR CLAMP PAD MOVES TOWARDS CURB TO
TIGHTEN LADDER TO RACK**

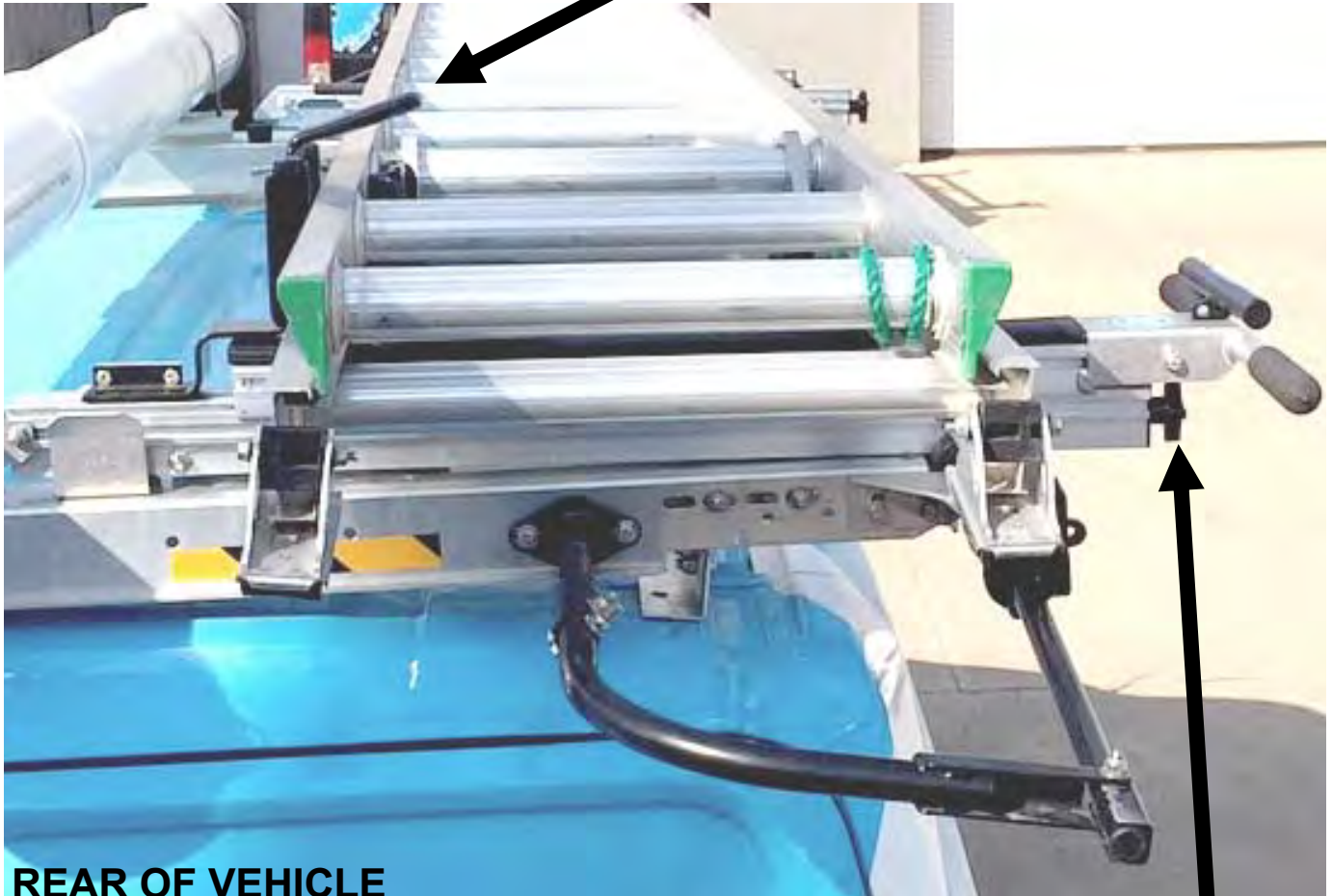

REAR OF VEHICLE



**TURN KNOB TO ADJUST TO
YOUR LADDER.**

**DO NOT OVER TIGHTEN!
CLAMP PAD SHOULD JUST
TOUCH THE LADDER.**

Proper Clamp Pad Locations

Below is the proper way to clamp the ladder to the vehicle (highlighted in green)

How to inspect for this: Properly placed clamp pads should be in close proximity to each other to allow the clamp pads to securely retain the ladder from side to side motion and front to back motion.

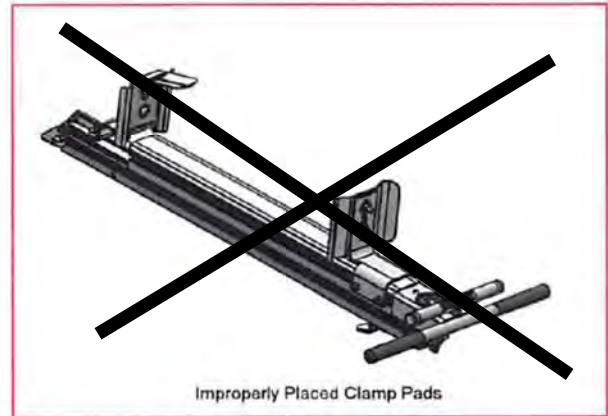
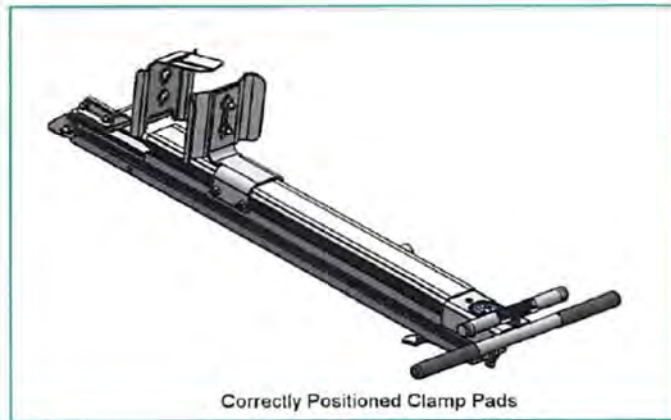

Above is the wrong way to clamp the ladder to the vehicle

**FRONT CLAMP PAD MOVES TOWARDS STREET
TO TIGHTEN LADDER TO RACK**



FRONT OF VEHICLE

**TURN KNOB TO ADJUST TO
YOUR LADDER.**

**DO NOT OVER TIGHTEN!
CLAMP PAD SHOULD JUST
TOUCH THE LADDER.**



DDL6 Series Final Adjustment Instruction (GMFSV / Ford Transit)

**DOUBLE CHECK ALL FASTENERS LOCATIONS TO BE SURE THAT ALL FASTENERS ARE
TIGHTENED TO SPECIFICATIONS.**

YOUR INSTALLATION IS NOW COMPLETE!

STOW THIS COPY IN THE VEHICLE FOR FUTURE REFERENCES!

Introduction / Comments:

THIS DROP DOWN UNIT IS CURB SIDE, STREET SIDE SPECIFIC. THE DROP DOWN IS FOR LOW ROOF VEHICLES, THESE INSTRUCTIONS WILL BE SHOWING THE GM FSV AND SOME FORD TRANSIT PICTURES FOR THE VEHICLE REPRESENTATION. THIS DROP DOWN LADDER RACK IS DESIGNED TO ADAPT TO AN ADRIAN STEEL CROSS BOW KIT FOR VARIOUS STANDARD ROOF VEHICLES.

Note:

It is advised that all fasteners used in this assembly and installation of this Rack should be checked for tightness at the following intervals: @ 2-weeks and again @ 6-weeks of operation. This preventive maintenance step must be completed to ensure your package gives you long service life.

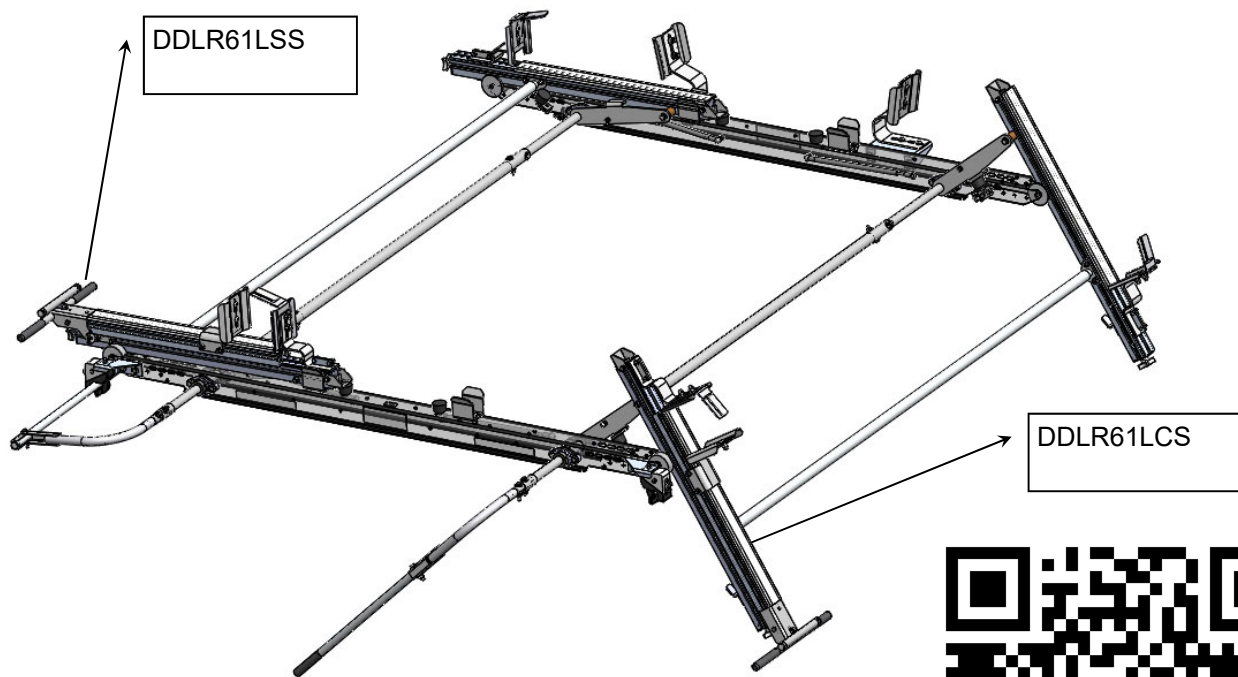

TO VIEW INSTALL VIDEO

**DDL61GM / DDL63GM
FINAL DROP DOWN LADDER RACK, STREET, CURB
GM FSV, LOW ROOF VAN**

- PRECAUTIONS -





 **CAUTION** 
**THE USE OF AIR IMPACT TOOLS CAN
OVER-TORQUE FASTENERS AND
CAUSE FASTENER FAILURE!**



 **CAUTION** 
**ALL INSTALLATION HOLES SHOULD BE SEALED
WITH SILICON OR BUTYL SEALANT TO PREVENT
EXHAUST FUMES FROM ENTERING THE VEHICLE!**



 **DANGER** 
**INSPECT FOR FUEL TANK, FUEL LINES, BRAKE LINES, HIGH
VOLTAGE BATTERIES AND ELECTRICAL LINES PRIOR TO
DRILLING TO AVOID DAMAGING CRITICAL VEHICLE SYSTEMS
OR INJURY TO INSTALLER DURING INSTALLATION PROCESS!**



 **CAUTION** 
**TO AVOID DAMAGING THE VEHICLE ALWAYS
USE DRILL STOPS WHEN DRILLING ANY IN-
STALLATION HOLES!**



- IMPORTANT WARRANTY REQUIREMENTS -

1. SUBSTITUTING ADRIAN STEEL SPECIFIED FASTENERS FOR ASSEMBLY AND/OR INSTALLATION WILL VOID YOUR PRODUCT WARRANTY.
2. ALL HOLES DRILLED INTO VEHICLE SHOULD HAVE THE RAW METAL EDGES SEALED WITH A SELF-ETCHING PRIMER TO RESIST CORROSION AND POTENTIAL FASTENER POINT FAILURE.
3. ALL FASTENERS USED IN THE INSTALLATION OF THIS PRODUCT SHOULD BE TIGHTENED TO THE TORQUE(S) SPECIFIED IN THESE INSTRUCTIONS.
4. THESE INSTRUCTIONS SHOULD BE KEPT WITH THE VEHICLE.

THE BASIC TOOLS NEEDED FOR MOST INSTALLATIONS



DRILL



DRILL BIT WITH
STOP

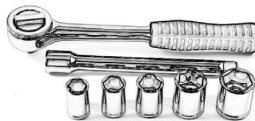

RATCHET, SOCKETS
AND/OR WRENCHES



SCREWDRIVERS



MEASURING TAPE

ADDITIONAL TOOLS MAY BE NEEDED FOR THIS INSTALLATION AND THEY WILL BE IDENTIFIED IN THE STEPS THAT FOLLOW.

BAG51041—FINAL ASSEMBLY FASTENER BAG

ITEM NO.	PART NUMBER	DESCRIPTION	QTY.
1	BAG0507-A	5" x 7" 3MIL AUTOBAG	1
2	FAS0246	Washer, Flat, 3/8, HRD, ZN	6
3	FAS0799	Screw, Hex Hd, 5/16-18x0.75 SS	4
4	FAS0110	Nut,Hex Nylk 3/8-16 SS W	4
5	FAS0572	Screw, Button Hd Hex Soc, 3/8-16x1.00 NI-ZN	2
6	FAS0588	Washer, Lock, Split, 5/16, SS	4
7	FAS0286	SCREW, HHCS, 3/8-16x4, SS	2
8	FAS0287	COTTER PIN, 1/16DIA X 1"LG, SS	2

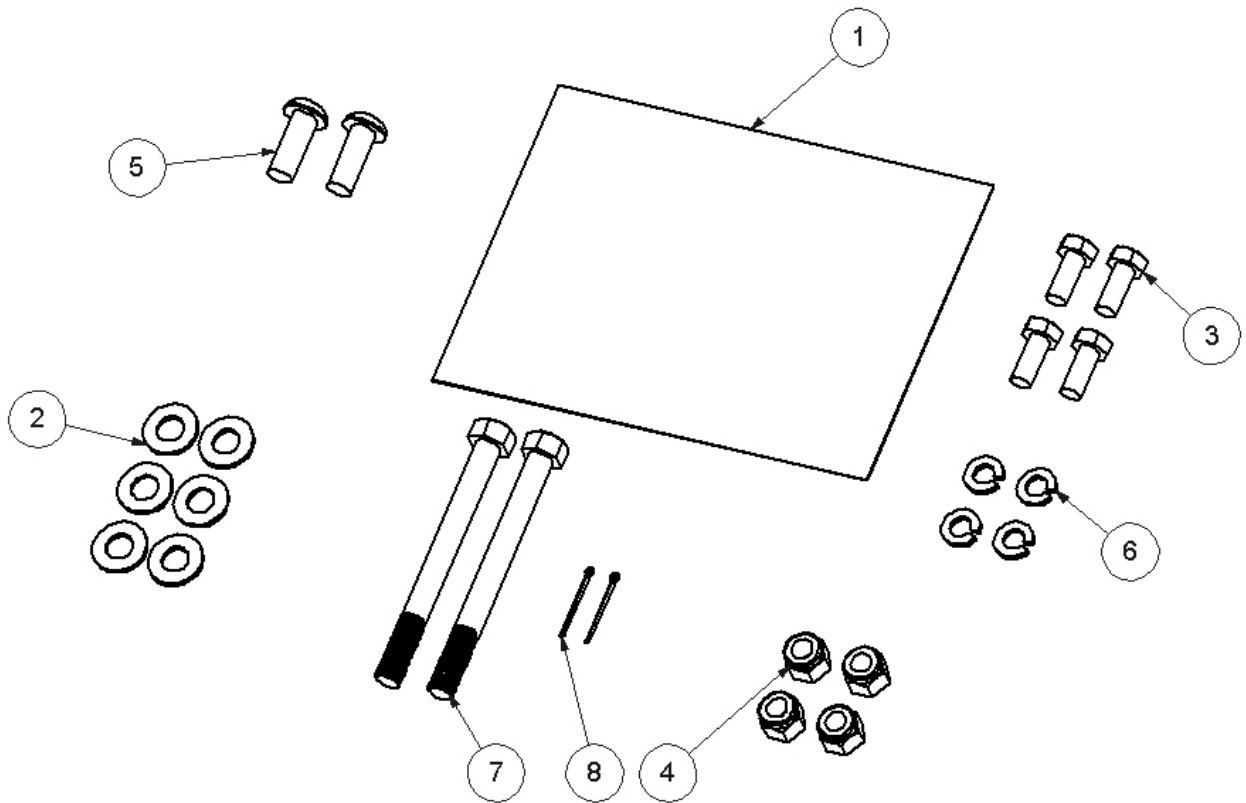



STEP 1A : THIS IS THE SHIP THRU SINGLE DROP DOWN AS YOU WOULD RECEIVE FOR FINAL DEALER ASSEMBLY. SEE STEP 1B FOR DOUBLE DROP DOWN.

SHOWING A GM FSV
RRKGMFSV
CROSS BOW KIT
ORDERED
SEPERATELY





STEP 1B : THIS IS THE SHIP THRU DOUBLE DROP DOWN AS YOU WOULD RECEIVE FOR FINAL DEALER ASSEMBLY

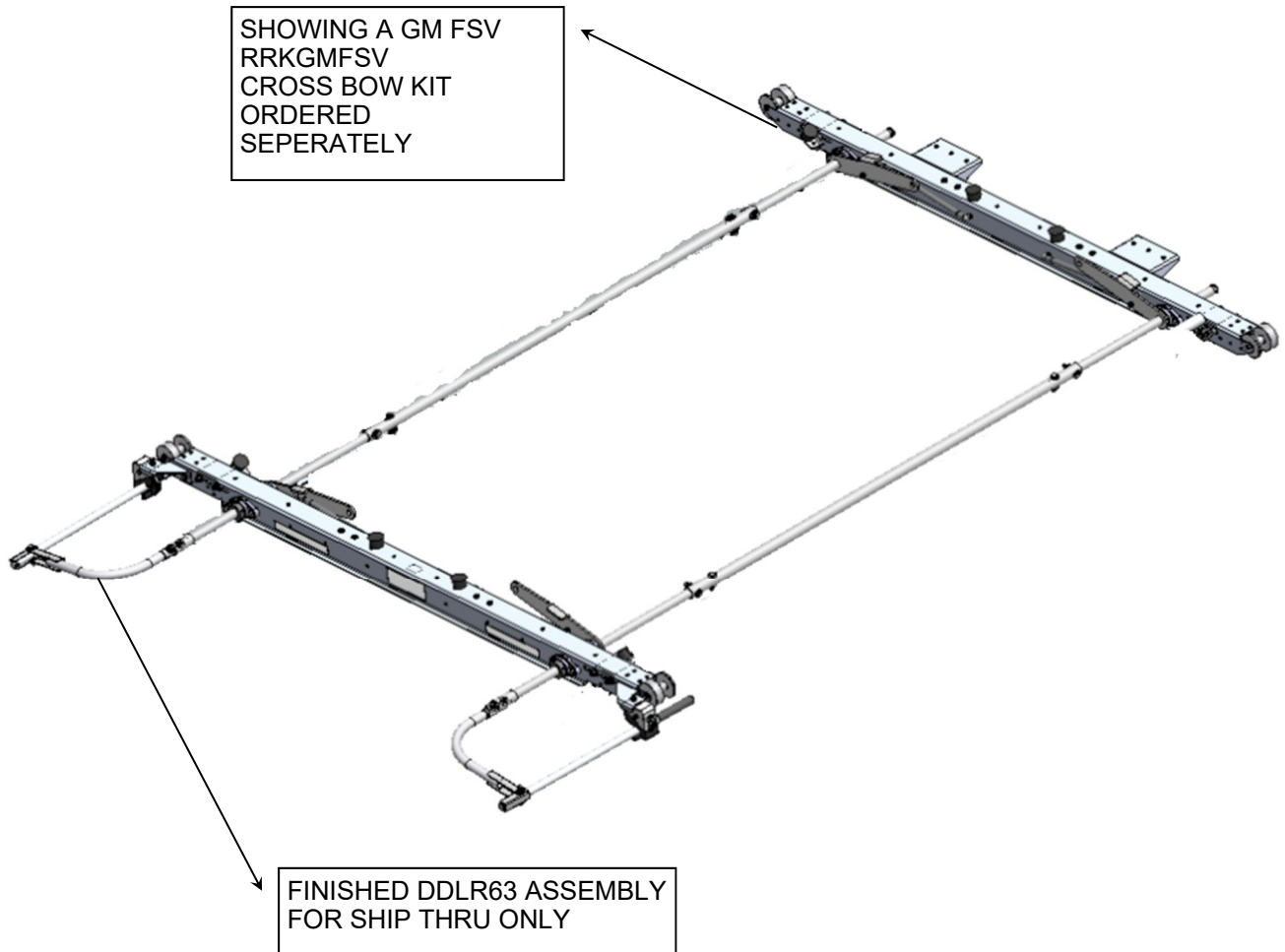

STEP 2 - THIS IS THE FINAL ASSEMBLY, SHOWING THE CURB AND STREET SIDE DROP DOWN COMPONENTS

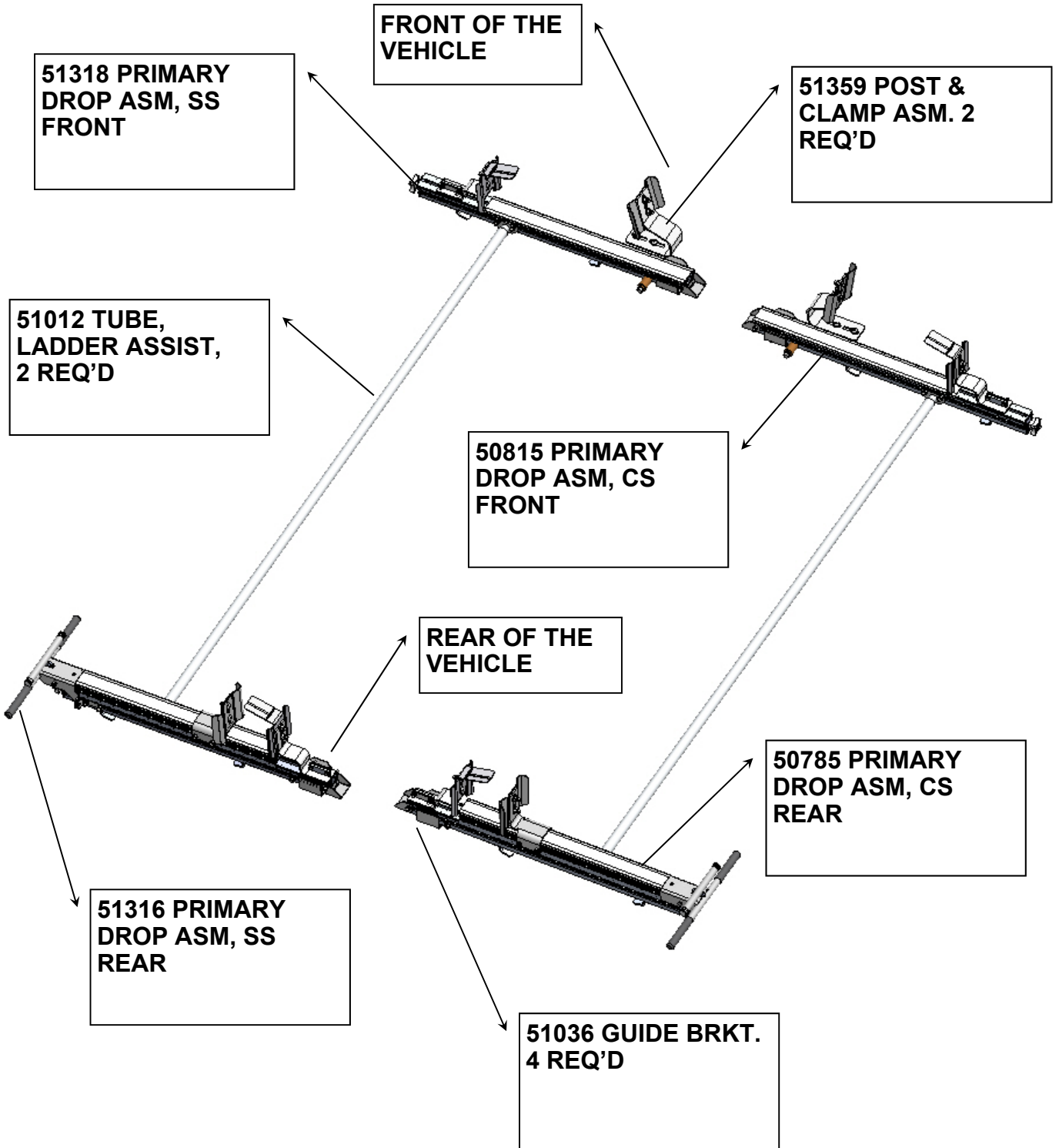

STEP 3 : ASSEMBLE BRACKETS TO THE FRONT CROSS BOW

NOTE: ITEM 51036 WILL VARY APPEARANCE AS EITHER VIEW OF 54178 SHOWN BELOW.

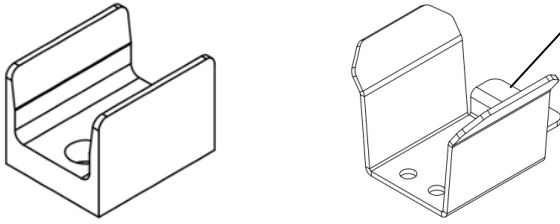

IF USING THIS STYLE, ENSURE THE REST FLANGE IS MOUNTING FACING TO THE OUTSIDE OF THE LADDER RACK! THIS WILL GIVE CLEARANCE FOR A CONDUIT KIT TO BE MOUNTED IN THE CENTER.

FAS0799— 5/16 X .75 HHCS
FAS0588— 5/16 LW
(2) EACH, 4 PLACES
THRU FRONT HOLES OF FRONT BRKTS AND REAR HOLES FOR REAR BRKTS INTO RIVNUTS IN CROSS BOWS

51359 POST & CLAMP ASM
2 PLACES

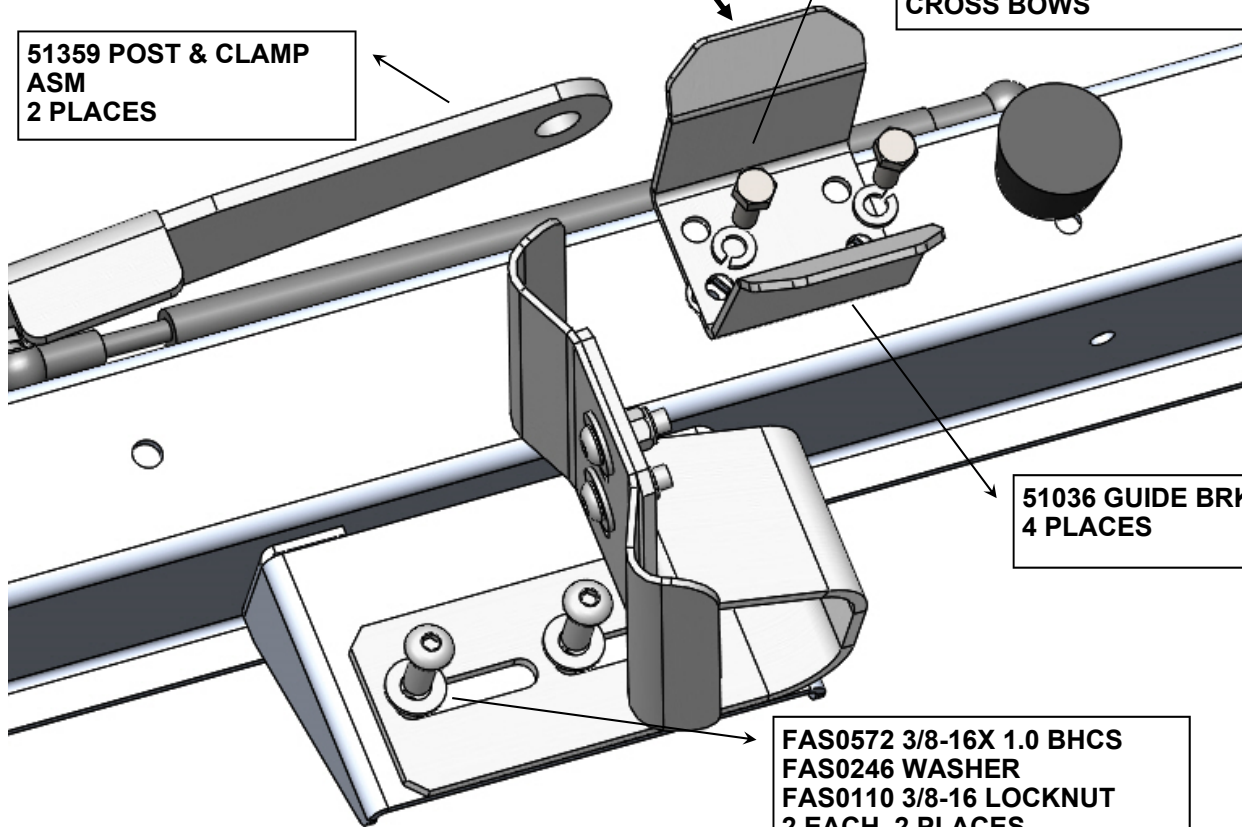

51036 GUIDE BRKT
4 PLACES

FAS0572 3/8-16X 1.0 BHCS
FAS0246 WASHER
FAS0110 3/8-16 LOCKNUT
2 EACH, 2 PLACES

COMPLETED VIEW OF THE FRONT CROSS BOW

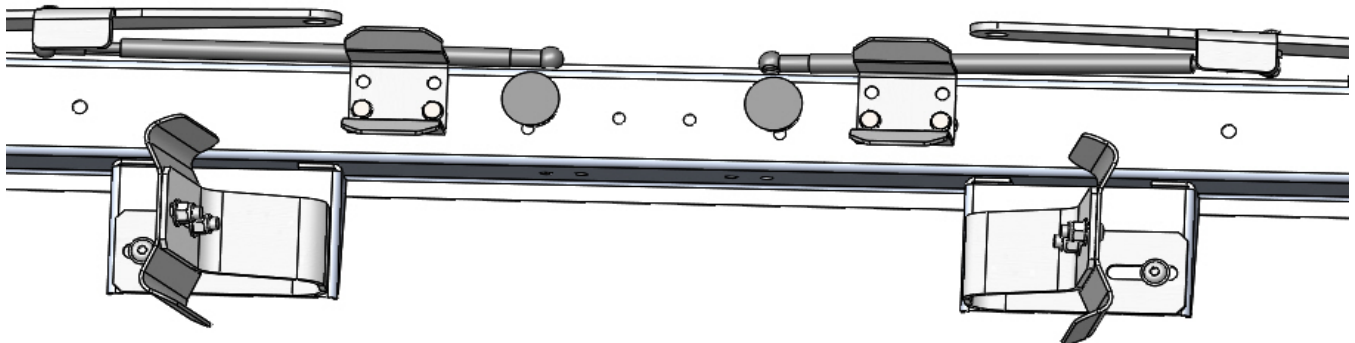

STEP 4 : ASSEMBLE REAR CURB SIDE PRIMARY DROP TO RACK

**SET 50785 PRIMARY DROP ASM, REAR CS IN PLACE ON REAR CROSS BOW.
USE GUIDE ROLLER TO HELP LOAD INTO POSITION**

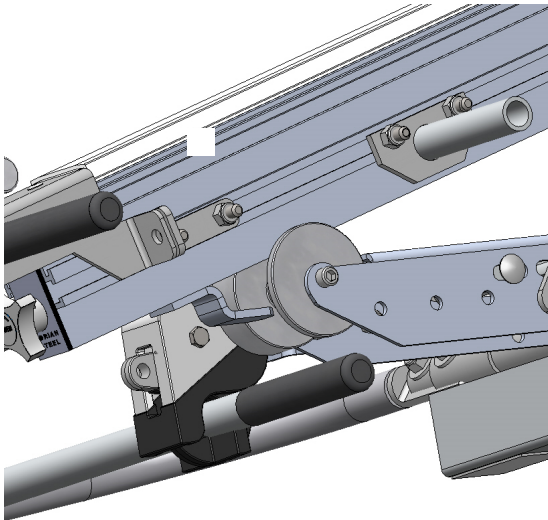

**50785 PRIMARY DROP
ASM CS REAR**

**50785 PRIMARY DROP
ASM, CS REAR**

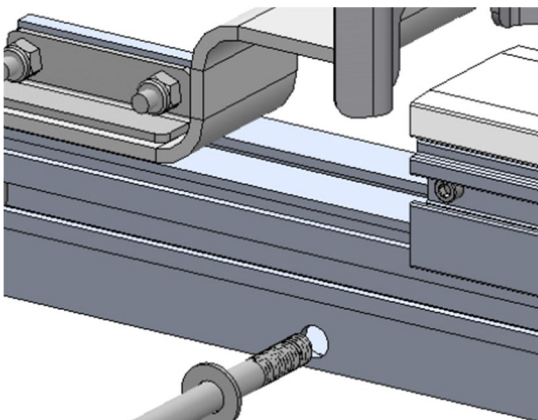
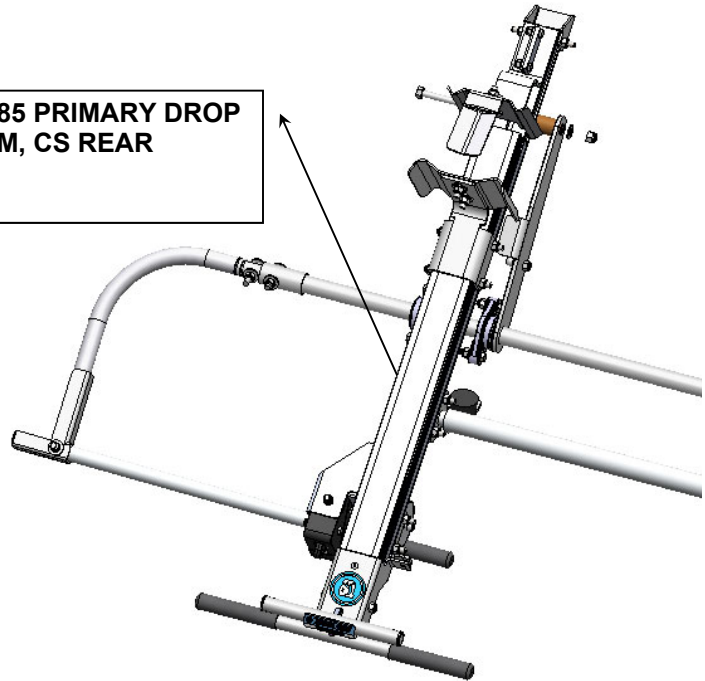

**FAS02826 3/8-16 X 4" HHCS
FAS0246 WASHER**

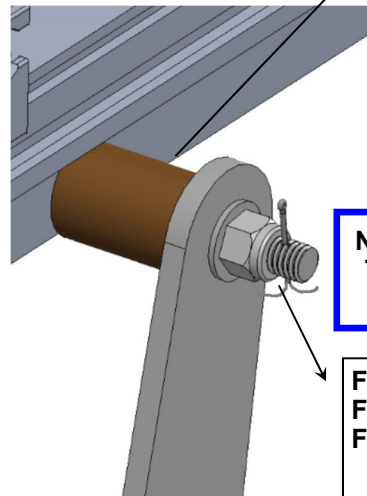

**51034 BRONZE
BUSHING**

**NOTE: TORQUE NYLOCK NUT
TO 20FT.LBS, THEN INSERT/
SECURE THE COTTER PIN.**

**FAS0246 WASHER
FAS0110 3/8-16 NYLOCK NUT
FAS0287—COTTER PIN**

**NOTE: AFTER THE COTTER
PIN IS INSERTED THROUGH
THE BOLT, SPREAD THE PIN
SO IT CAN NOT BE REMOVED.**

STEP 5 : ASSEMBLE FRONT SIDE PRIMARY DROP TO RACK

**SET 50815 PRIMARY DROP ASM, FRONT CS IN PLACE ON FRONT CROSS BOW.
USE GUIDE ROLLER AFTER LADDER ASSIST TUBE IS ON BOTH STUB SHAFTS**

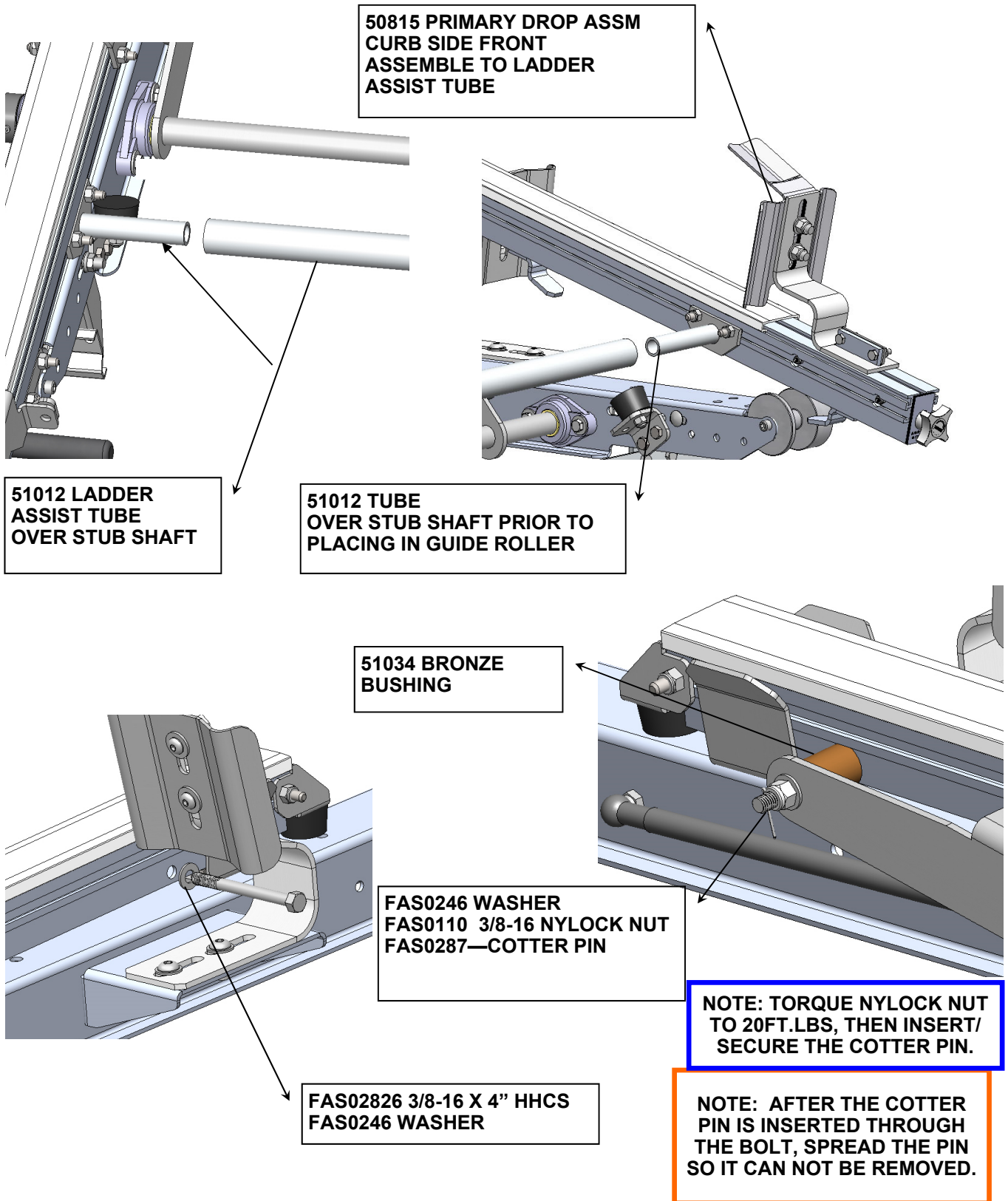



**STEP #6 : FOR A DOUBLE DROP DOWN, INSTALL STREET SIDE USING
STEPS #4 & #5 AS YOUR GUIDE.**

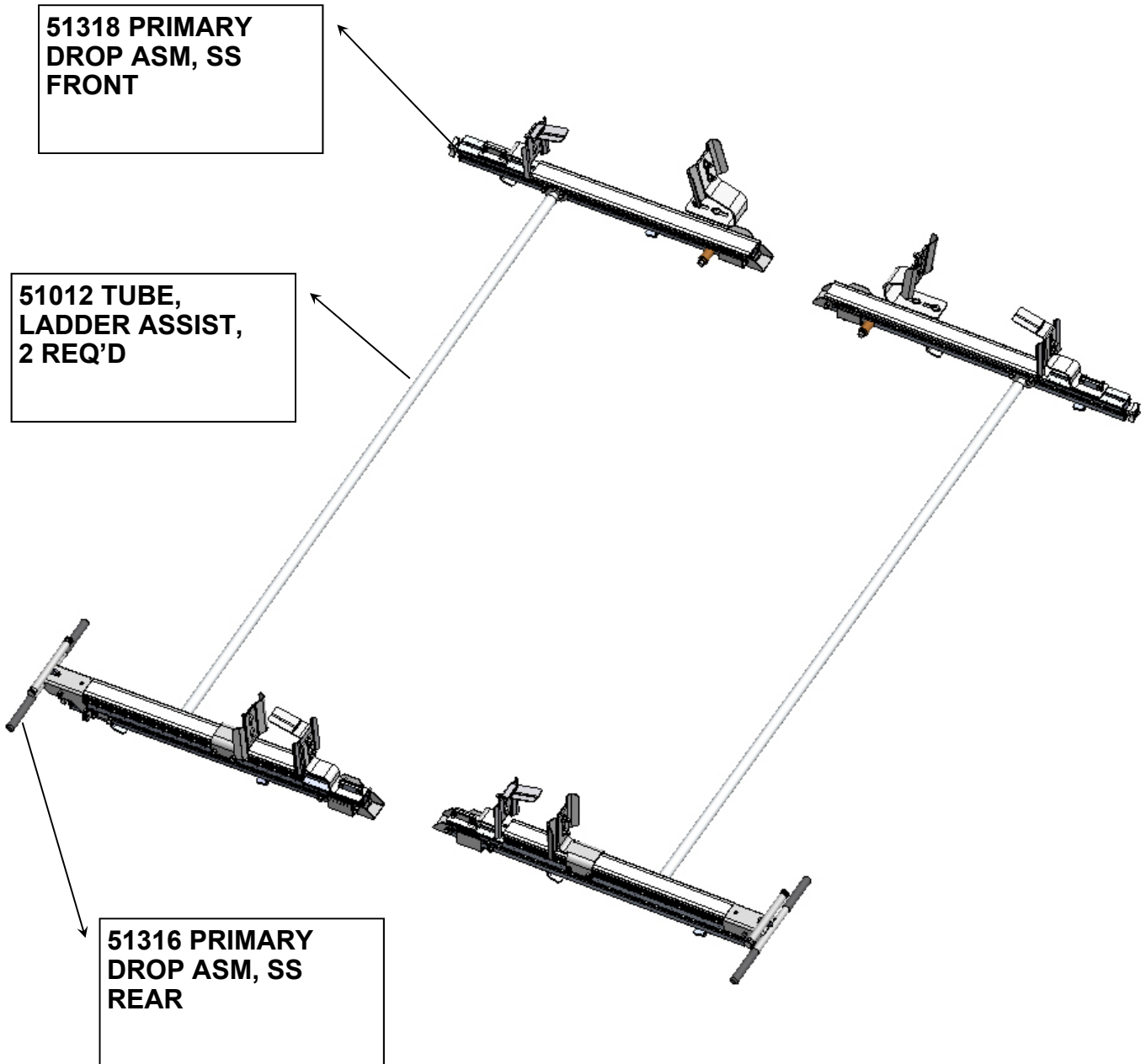

**DOUBLE CHECK ALL FASTENERS LOCATIONS TO BE SURE THAT ALL
FASTENERS ARE TIGHTENED TO SPECIFICATIONS.
YOUR INSTALLATION IS NOW COMPLETE!
STOW THIS COPY IN THE VEHICLE FOR FUTURE REFERENCES!**



**STEP #7 : YOUR DOUBLE DROP DOWN INSTALLATION IS NOW COMPLETE
FOR A COMBO RACK, GO TO STEP 8**



**DOUBLE CHECK ALL FASTENERS LOCATIONS TO BE SURE THAT ALL
FASTENERS ARE TIGHTENED TO SPECIFICATIONS.
YOUR INSTALLATION IS NOW COMPLETE!
STOW THIS COPY IN THE VEHICLE FOR FUTURE REFERENCES!**



STEP #08 : COMBO RACK, FINAL INSTALL- STREET SIDE GRIP LOCK



STEP #9 : COMBO RACK, INSTALL STREET SIDE GRIP LOCK

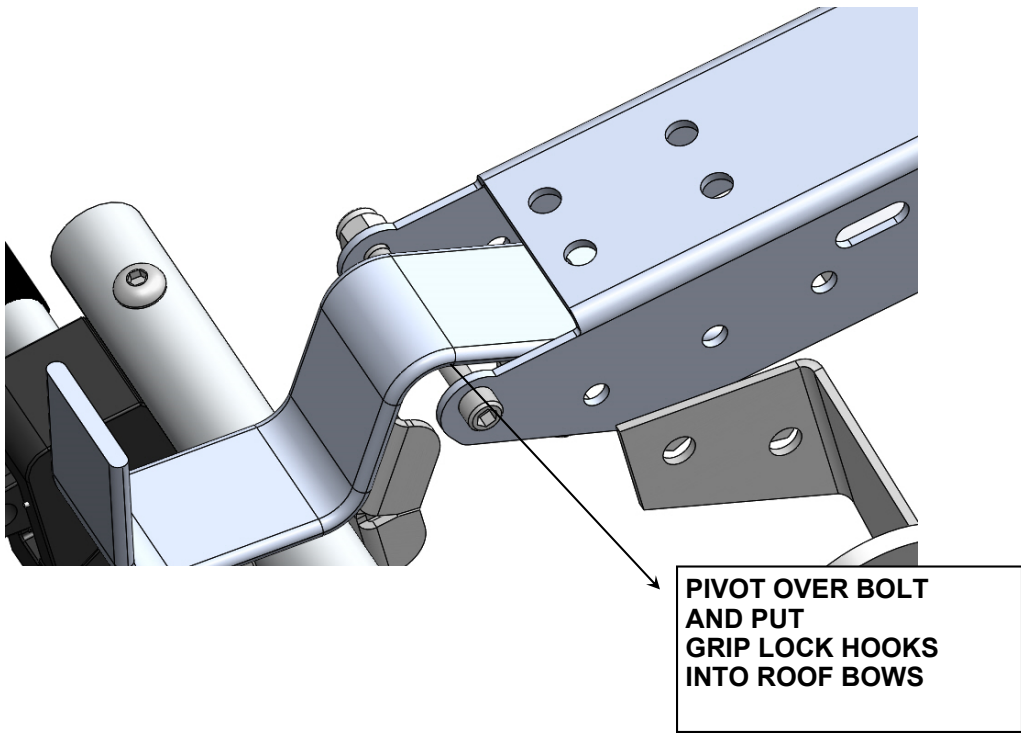

SECOND AND THIRD HOLES !
FAS0799— 5/16 x 3/4 HHCS (2)
FAS0248— NYLOCK (2)

REAR ROOF BOW

FAS0820— 3/8 X 1 LG BHCS (4)
FAS0110— NYLOCK (4)

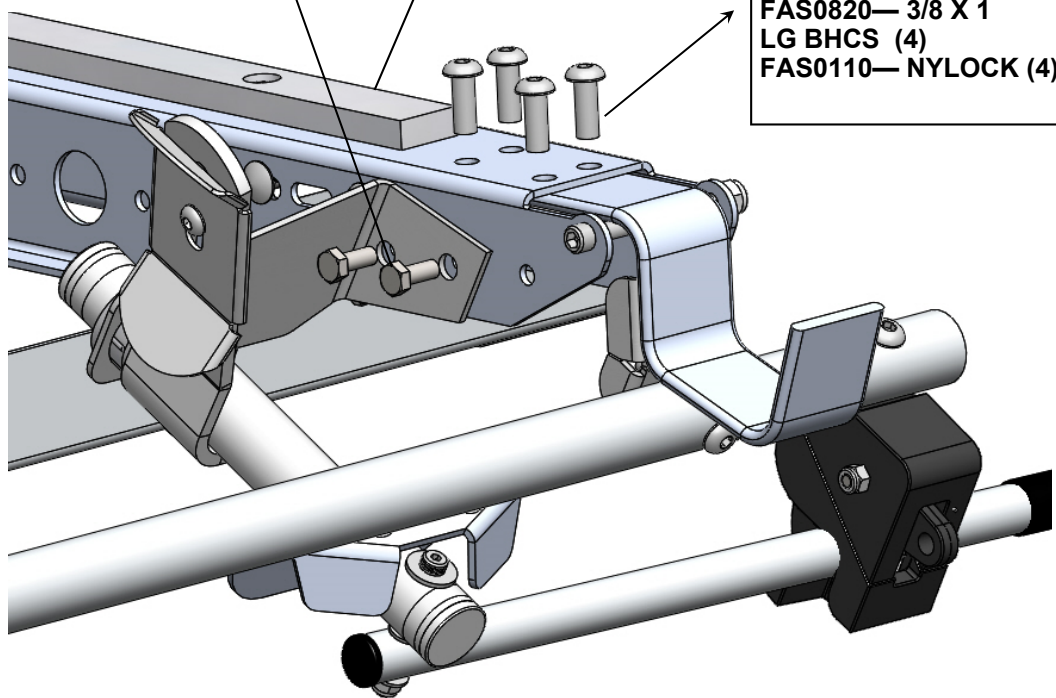

STEP #10: FRONT ROOF BOW ASSEMBLY –STREET SIDE

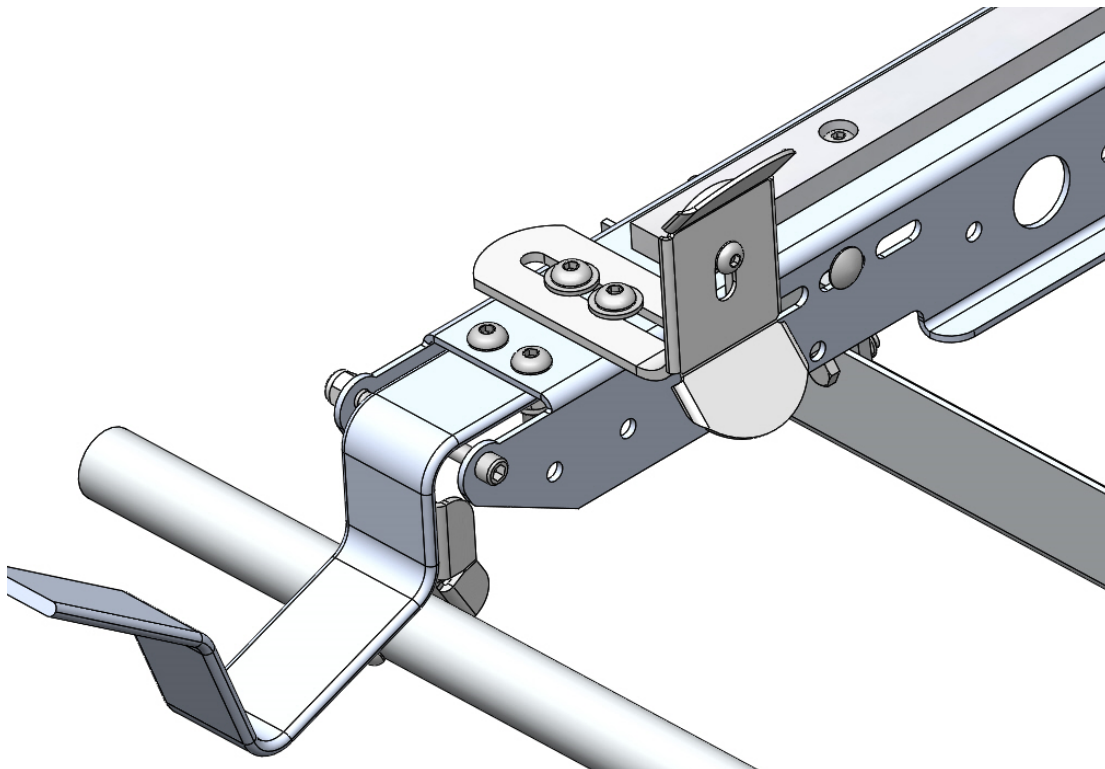
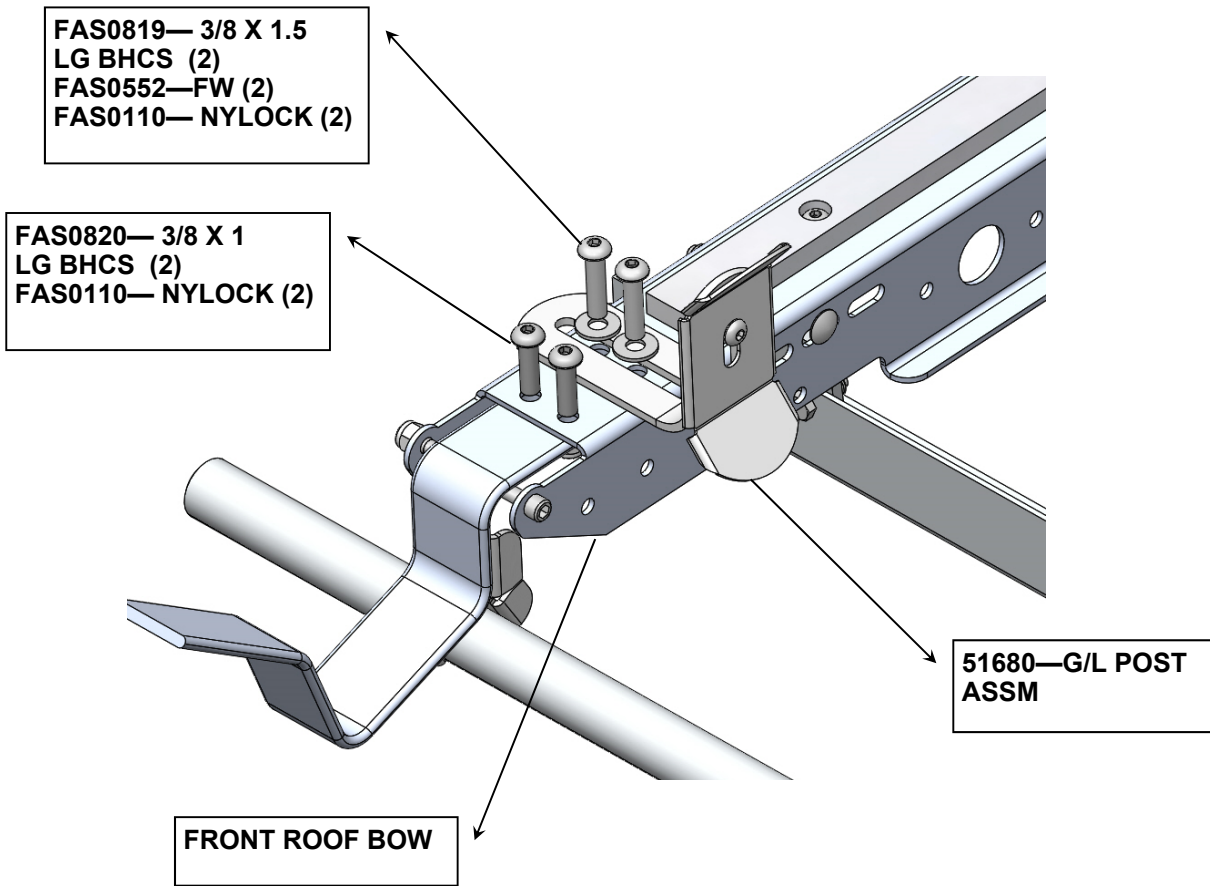

STEP #23 : YOUR DROP DOWN COMBO INSTALLATION IS NOW COMPLETE



**DOUBLE CHECK ALL FASTENERS LOCATIONS TO BE SURE THAT ALL
FASTENERS ARE TIGHTENED TO SPECIFICATIONS.
YOUR INSTALLATION IS NOW COMPLETE!
STOW THIS COPY IN THE VEHICLE FOR FUTURE REFERENCES!**

**REAR CLAMP PAD MOVES TOWARDS CURB TO
TIGHTEN LADDER TO RACK**

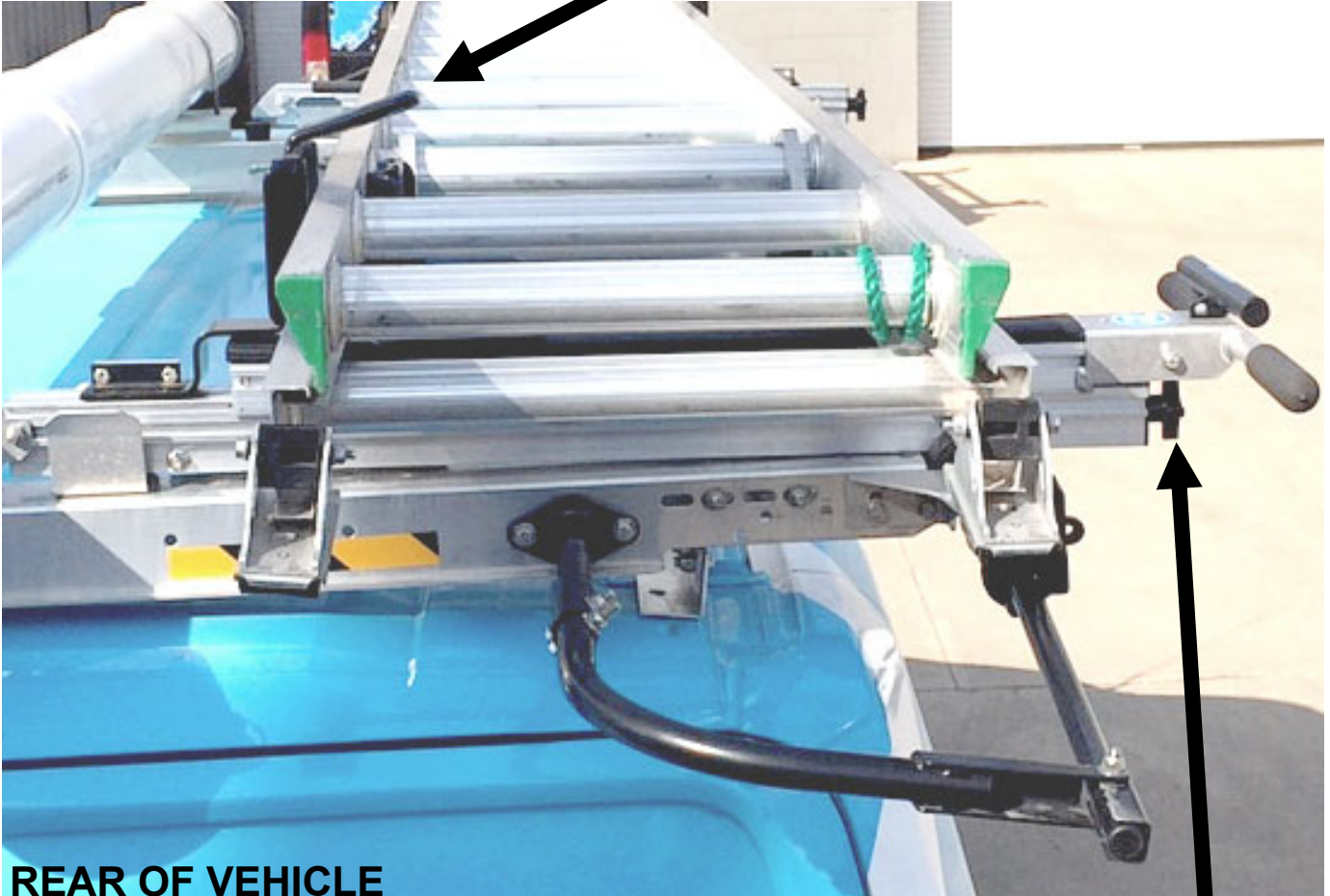

REAR OF VEHICLE



**TURN KNOB TO ADJUST TO
YOUR LADDER.**

**DO NOT OVER TIGHTEN!
CLAMP PAD SHOULD JUST
TOUCH THE LADDER.**

DDL61 Series Final Adjustment Instruction (GMFSV / Ford Transit)

Proper Clamp Pad Locations

Below is the proper way to clamp the ladder to the vehicle (highlighted in green)

How to inspect for this: Properly placed clamp pads should be in close proximity to each other to allow the clamp pads to securely retain the ladder from side to side motion and front to back motion.

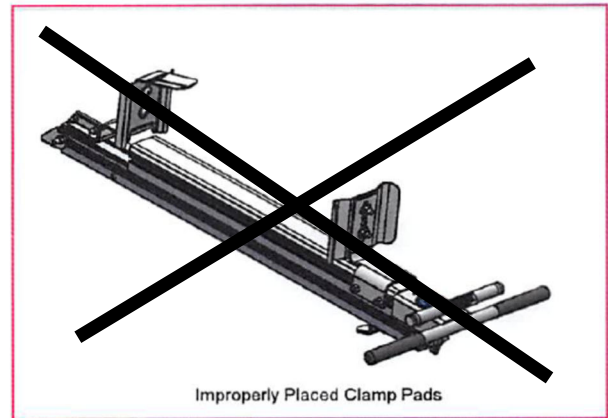
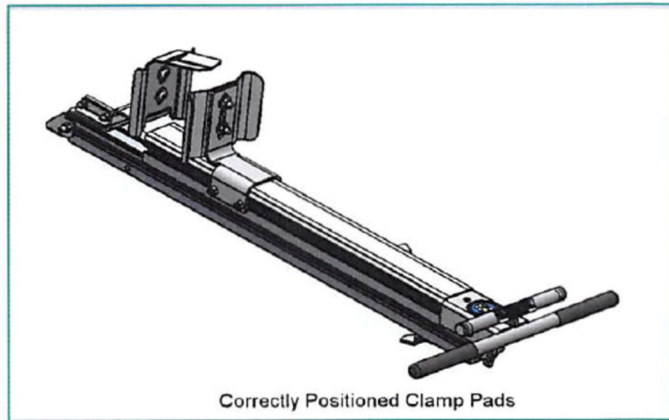

Above is the wrong way to clamp the ladder to the vehicle

**FRONT CLAMP PAD MOVES TOWARDS STREET
TO TIGHTEN LADDER TO RACK**



**TURN KNOB TO ADJUST TO
YOUR LADDER.**

**DO NOT OVER TIGHTEN!
CLAMP PAD SHOULD JUST
TOUCH THE LADDER.**



DDL61 Series Final Adjustment Instruction (GMFSV / Ford Transit)

**DOUBLE CHECK ALL FASTENERS LOCATIONS TO BE SURE THAT ALL FASTENERS ARE
TIGHTENED TO SPECIFICATIONS.**

YOUR INSTALLATION IS NOW COMPLETE!

STOW THIS COPY IN THE VEHICLE FOR FUTURE REFERENCES!

STEP #10A: HOW TO ADJUST THE CLAMP PADS

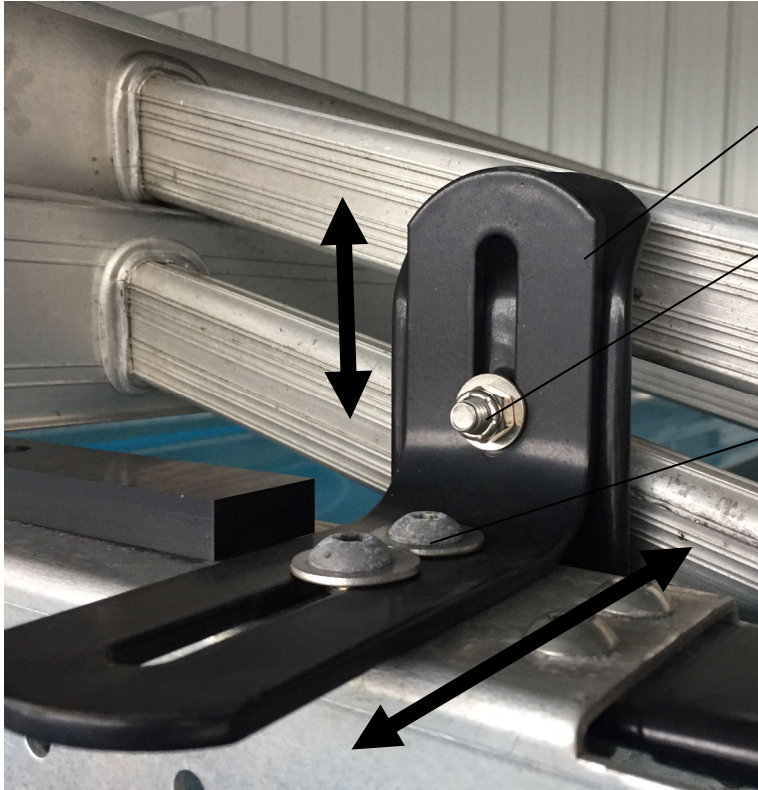

FRONT BRACKET

ADJUST VERTICALLY TO YOUR LADDER

ALL OF THE HORIZONTAL ADJUSTMENT IS IN THIS BRACKET.

REAR LOCKING PIVOT BRACKET

ADJUST VERTICALLY TO YOUR LADDER. SHOWING A STEP LADDER

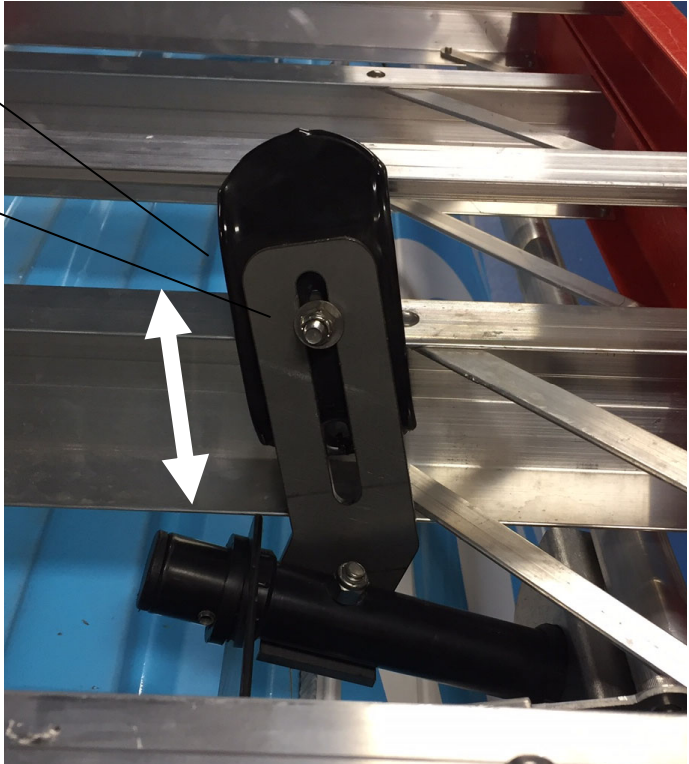

**DOUBLE CHECK ALL FASTENERS LOCATIONS TO BE SURE THAT ALL FASTENERS ARE TIGHTENED TO SPECIFICATIONS.
YOUR INSTALLATION IS NOW COMPLETE!
STOW THIS COPY IN THE VEHICLE FOR FUTURE REFERENCES!**

STEP #10B : HOW TO ADJUST THE CLAMP PADS

- A) Load your ladder onto the ladder rack (see page 14) and latch the HANDLE BAR into the HANDLE LATCH.
- B) Now slide the ladder back towards the rear of the vehicle and slide the rear CLAMP BRACKET to fit snug over and against the top ladder rung. ** See bottom illustration for STEP LADDERS ! **
SEE ILLUSTRATION BELOW.
- C) Next slide the FRONT STOP POST at the front of the ladder rack back towards the rear of the vehicle and fit the front CLAMP BRACKET to the top ladder rung the same as the rear.
- D) Firmly tighten both front and rear CLAMP BRACKETS to their posts and tighten snug the FRONT STOP POST to the front CROSS SUPPORT.
- E) Now unlatch the HANDLE BAR and unload your ladder. Next loosen the FRONT STOP POST and slide it out towards the rear of the vehicle 1/2" and FIRMLY RETIGHTEN !
YOUR LADDER RACK SHOULD NOW BE ADJUSTED FOR YOUR LADDER.

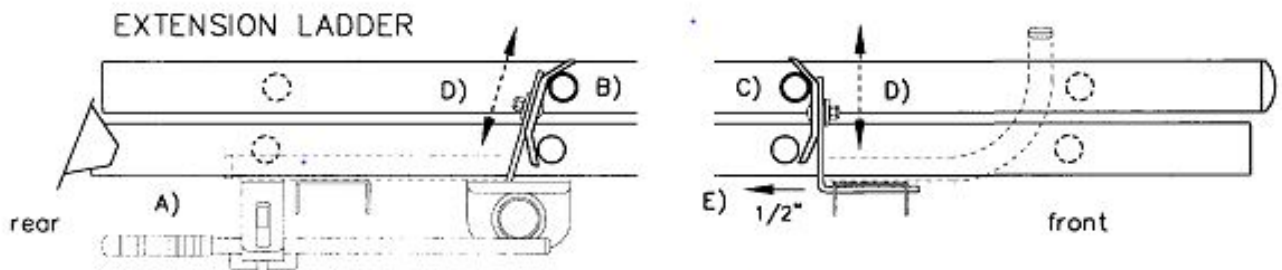

CAUTION: Never clamp up the first step and the head of the STEP LADDER !

Front CLAMP BRACKET must be attached like this !

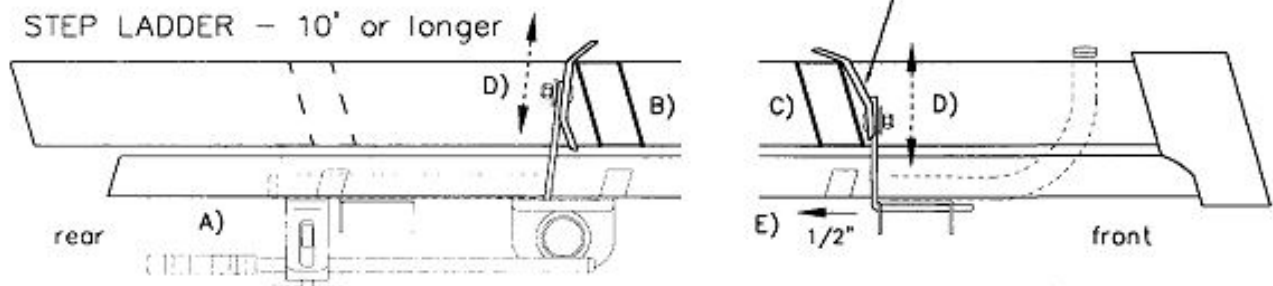

**DOUBLE CHECK ALL FASTENERS LOCATIONS TO BE SURE THAT ALL FASTENERS ARE TIGHTENED TO SPECIFICATIONS.
YOUR INSTALLATION IS NOW COMPLETE!
STOW THIS COPY IN THE VEHICLE FOR FUTURE REFERENCES!**



PRODUCT WEIGHT
31 lbs

WIDTH x DEPTH x HEIGHT

CAPACITY
190

COLOR
Aluminum

CATALOG NUMBER
RRKFTM

PRODUCT FEATURES

This Roof Cross-bow Kit is designed to fit the Ford Transit Mid roof vehicle, 130 and 148 wheel base. This base kit allows mounting of the new re-designed drop down.

Cross-bow kits is secured to the Ford Transit by OEM supplied fastening points.

SEE PAGE 2 FOR APPLICATION NOTES AND ACCESSORIES, OTHER PRODUCTS THAT WORK WITH THIS UNIT.



**ROOF RAIL KIT, DROP DOWN LDRK, FORD
TRANSIT, MID ROOF**

CATALOG NUMBER RRKFTM

PRODUCT APPLICATION

This Roof Cross-bow Kit is designed to fit the Ford Transit, Mid roof vehicle, 130 and 148 wheel base. This will allow mounting of the new re-designed drop down ladder rack.

ACCESSORIES THAT WILL WORK WITH THIS PRODUCT

<i>CATALOG NUMBER</i>	<i>DESCRIPTION</i>
DDL61MCS	DROP DOWN LADDER RACK, CURB SIDE, MID
DDL61MSS	DROP DOWN LADDER RACK, STREET SIDE, MID

SPECIAL APPLICATION NOTES



Introduction / Comments:

THIS ROOF RAIL AND CROSS BOW KIT IS DESIGNED FOR THE FORD TRANSIT MID ROOF VANS, BOTH 130" AND 148" WHEEL BASE. IT IS THE BASE UNIT FOR ALL OF THE LADDER RACK COMBINATIONS FOR THIS VEHICLE. THE SINGLE AND DOUBLE DROP DOWN LADDER RACK.

Note:

It is advised that all fasteners used in this assembly and installation of this Rack should be checked for tightness at the following intervals: @ 2-weeks and again @ 6-weeks of operation. This preventive maintenance step must be completed to ensure your package gives you long service life.



RRKFTM ROOF RAIL AND CROSS BOW KIT FORD TRANSIT MID ROOF VANS

- PRECAUTIONS -





 **CAUTION** 
**THE USE OF AIR IMPACT TOOLS CAN
OVER-TORQUE FASTENERS AND
CAUSE FASTENER FAILURE!**



 **CAUTION** 
**ALL INSTALLATION HOLES SHOULD BE SEALED
WITH SILICON OR BUTYL SEALANT TO PREVENT
EXHAUST FUMES FROM ENTERING THE VEHICLE!**



 **DANGER** 
**INSPECT FOR FUEL TANK, FUEL LINES, BRAKE LINES, HIGH
VOLTAGE BATTERIES AND ELECTRICAL LINES PRIOR TO
DRILLING TO AVOID DAMAGING CRITICAL VEHICLE SYSTEMS
OR INJURY TO INSTALLER DURING INSTALLATION PROCESS!**



 **CAUTION** 
**TO AVOID DAMAGING THE VEHICLE ALWAYS
USE DRILL STOPS WHEN DRILLING ANY IN-
STALLATION HOLES!**



- IMPORTANT WARRANTY REQUIREMENTS -

1. SUBSTITUTING ADRIAN STEEL SPECIFIED FASTENERS FOR ASSEMBLY AND/OR INSTALLATION WILL VOID YOUR PRODUCT WARRANTY.
2. ALL HOLES DRILLED INTO VEHICLE SHOULD HAVE THE RAW METAL EDGES SEALED WITH A SELF-ETCHING PRIMER TO RESIST CORROSION AND POTENTIAL FASTENER POINT FAILURE.
3. ALL FASTENERS USED IN THE INSTALLATION OF THIS PRODUCT SHOULD BE TIGHTENED TO THE TORQUE(S) SPECIFIED IN THESE INSTRUCTIONS.
4. THESE INSTRUCTIONS SHOULD BE KEPT WITH THE VEHICLE.

THE BASIC TOOLS NEEDED FOR MOST INSTALLATIONS



DRILL



DRILL BIT WITH
STOP



RATCHET, SOCKETS
AND/OR WRENCHES



SCREWDRIVERS



MEASURING TAPE

ADDITIONAL TOOLS MAY BE NEEDED FOR THIS INSTALLATION AND THEY WILL BE IDENTIFIED IN THE STEPS THAT FOLLOW.

BAG50896 - FASTENER BAG

ITEM NO.	PART NUMBER	DESCRIPTION	BAG50896/QTY.
1	BAG0406-A	4" x 6" 3MIL AUTOBAG	1
2	FAS0552	Washer, Flat, 5/16, SST	16
3	FAS0597	Screw, Hex Hd, 5/16-18x 1.00 SST	8
4	FAS0248	Nut, Nylon Insert Lock, 5/16-18 SST	16
5	FAS0808	Bolt, Carriage, 5/16-18x3 1/2	8

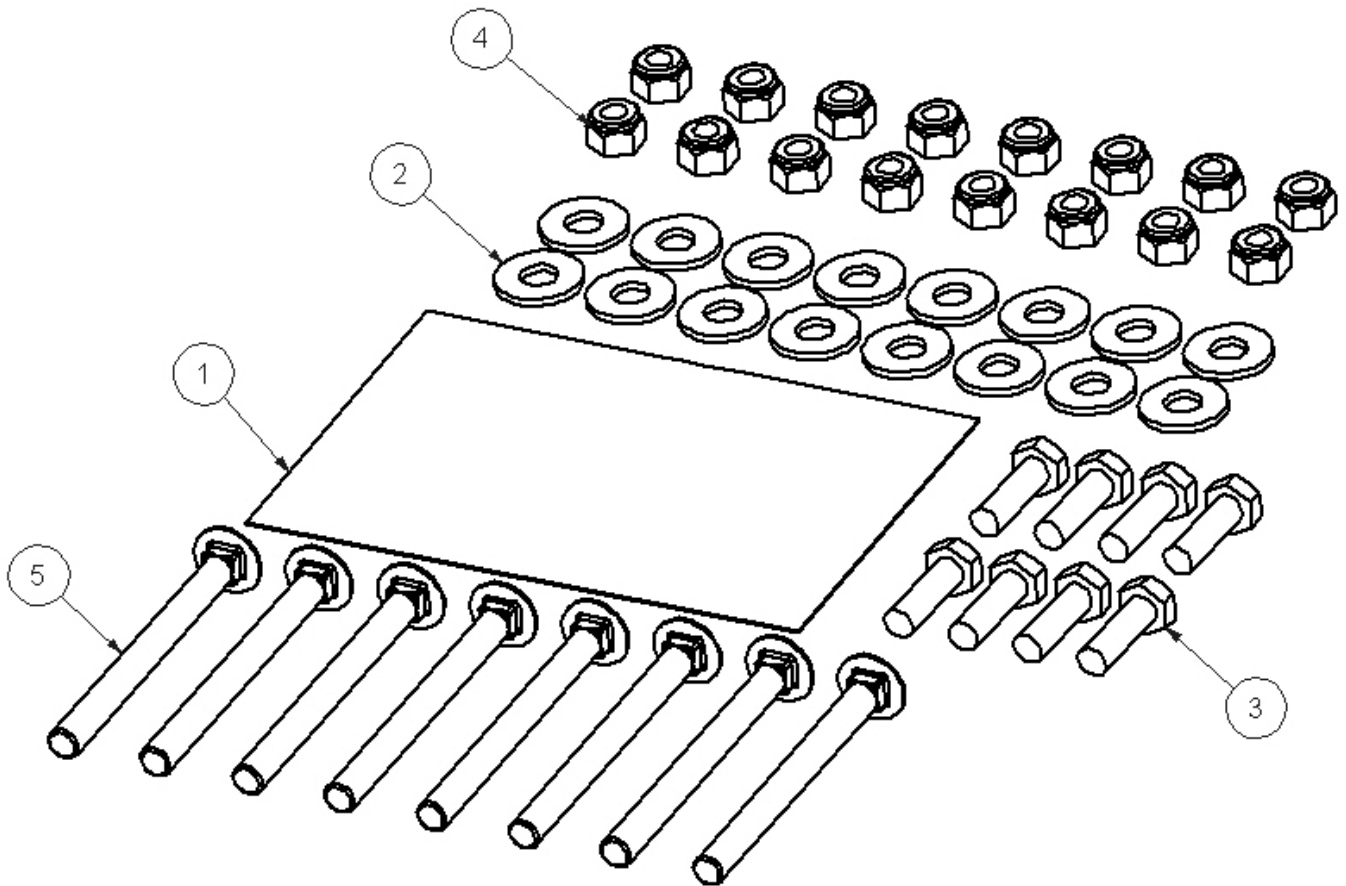

BAGRRKFTM—FASTENER BAG, ROOF RAIL KIT

ITEM NO.	PART NUMBER	DESCRIPTION	QTY.
1	BAG0406-A	4" x 6" 3 MIL AUTOBAG	1
2	FAS0351	SCREW, HHCS, M8-1.25 X 40MM LG	6
3	FAS0552	Washer, Flat, 5/16, SST	6
4	FAS0588	Washer, Lock, Split, 5/16, SS	6
5	05586-0	Butyl Tape, T224 -1/2"X 1' Roll	1
6	26618-0	Silicone Sealant	1

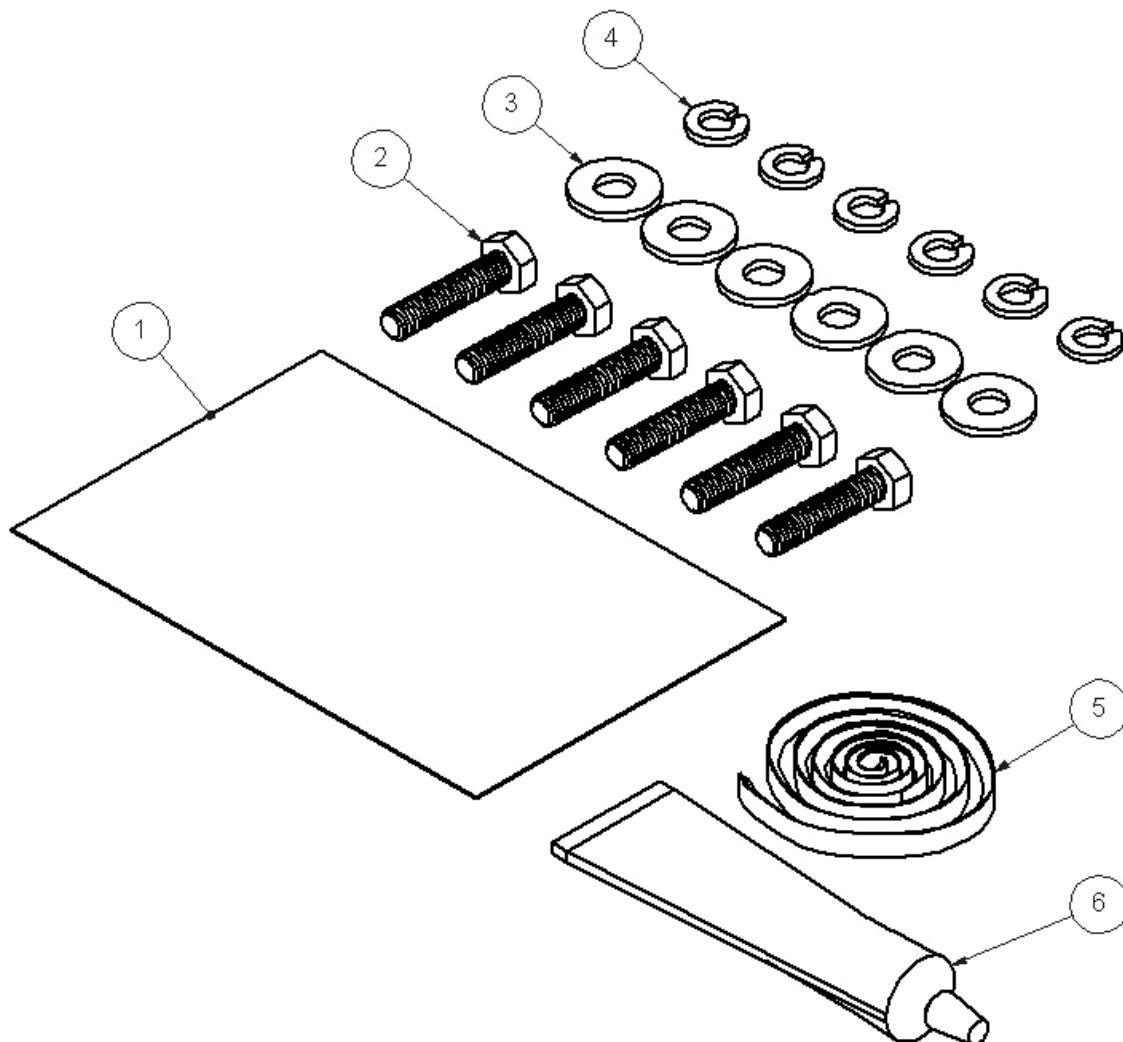



STEP #1 : PREP ROOF RAILS—130 WHEEL BASE

52036 STREET SIDE ROOF RAIL
TOE UP TO THE OUTSIDE

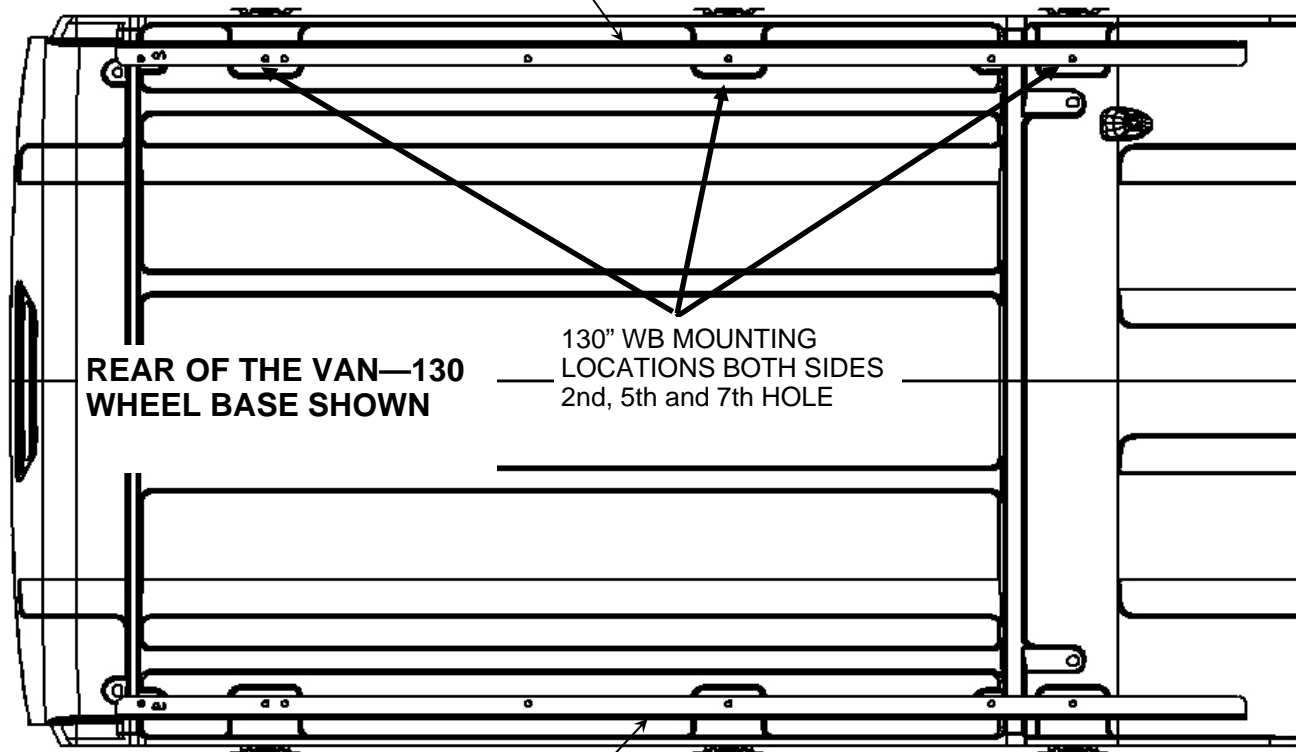

**REAR OF THE VAN—130
WHEEL BASE SHOWN**

130" WB MOUNTING
LOCATIONS BOTH SIDES
2nd, 5th and 7th HOLE

52037 CURB SIDE ROOF RAIL
TOE UP TO THE OUTSIDE

52036 STREET SIDE ROOF RAIL
TOE UP TO THE OUTSIDE

REAR OF VAN

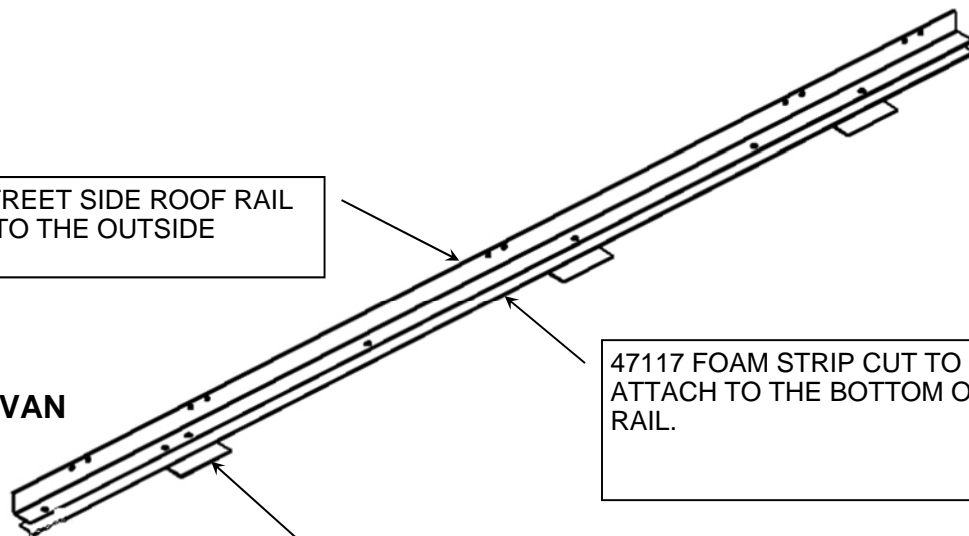

47117 FOAM STRIP CUT TO 95" AND
ATTACH TO THE BOTTOM OF THE
RAIL.

52710, PLACE THE 3/8 THICK RUBBER
SPACER UNDER EACH HOLE TO BE
USED AS SHOWN.



STEP #1 : PREP ROOF RAILS—148 WHEEL BASE

52036 STREET SIDE ROOF RAIL
TOE UP TO THE OUTSIDE

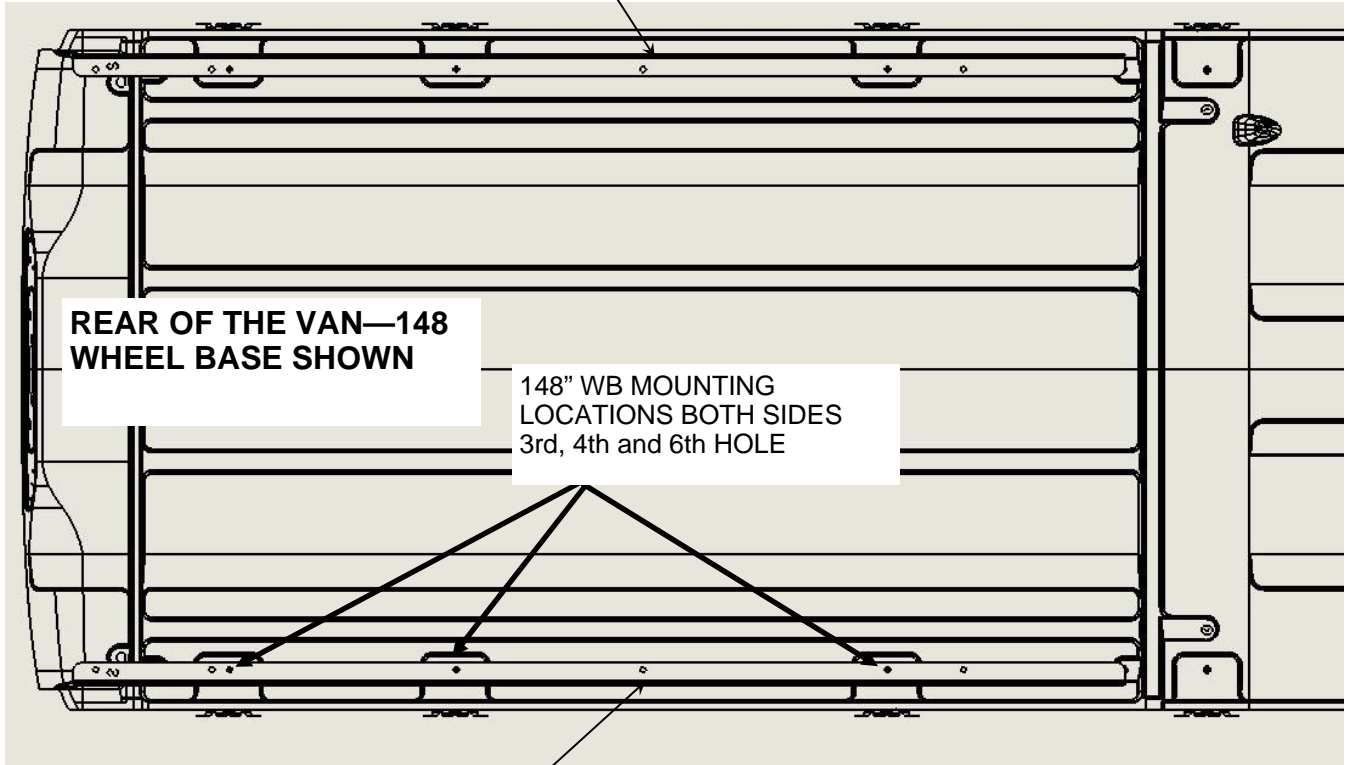

**REAR OF THE VAN—148
WHEEL BASE SHOWN**

148" WB MOUNTING
LOCATIONS BOTH SIDES
3rd, 4th and 6th HOLE

52037 CURB SIDE ROOF RAIL
TOE UP TO THE OUTSIDE

52036 STREET SIDE ROOF RAIL
TOE UP TO THE OUTSIDE

REAR OF VAN

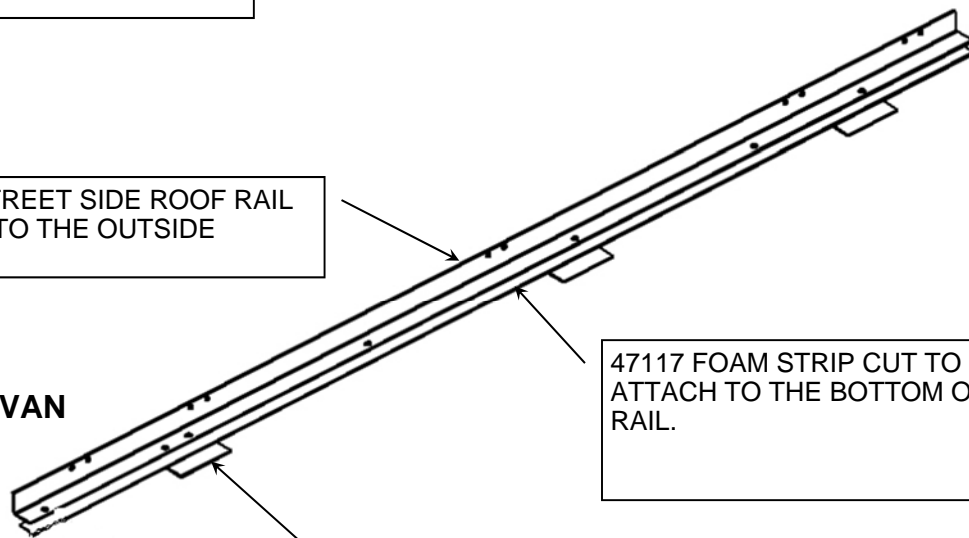

47117 FOAM STRIP CUT TO 95" AND
ATTACH TO THE BOTTOM OF THE
RAIL.

52710, PLACE THE 3/8 THICK RUBBER
SPACER UNDER EACH HOLE TO BE
USED AS SHOWN.



STEP #2 : ASSEMBLE REAR CROSS BOW TO THE ROOF RAILS

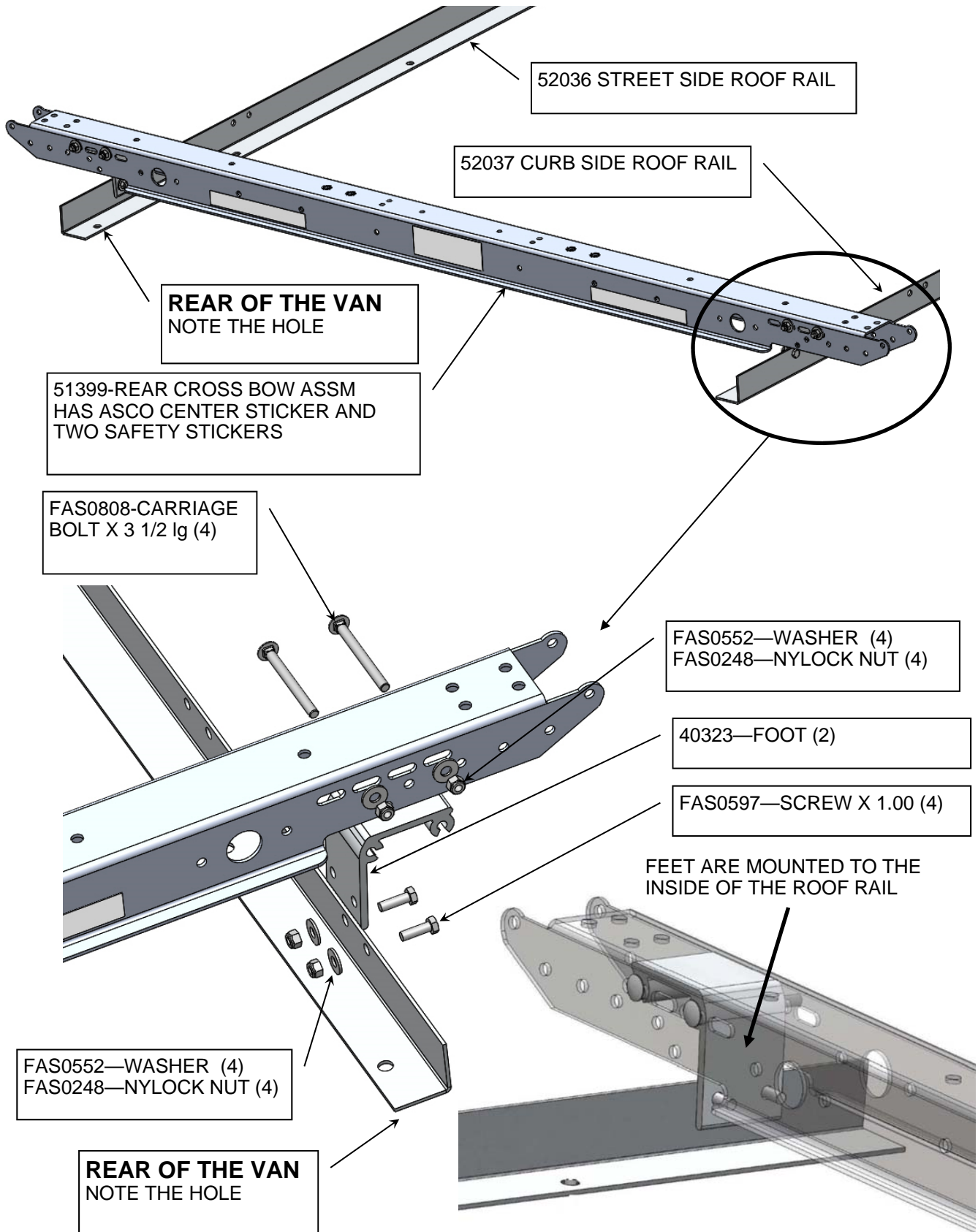



STEP #3 : ASSEMBLE FRONT CROSS BOW TO THE ROOF RAILS

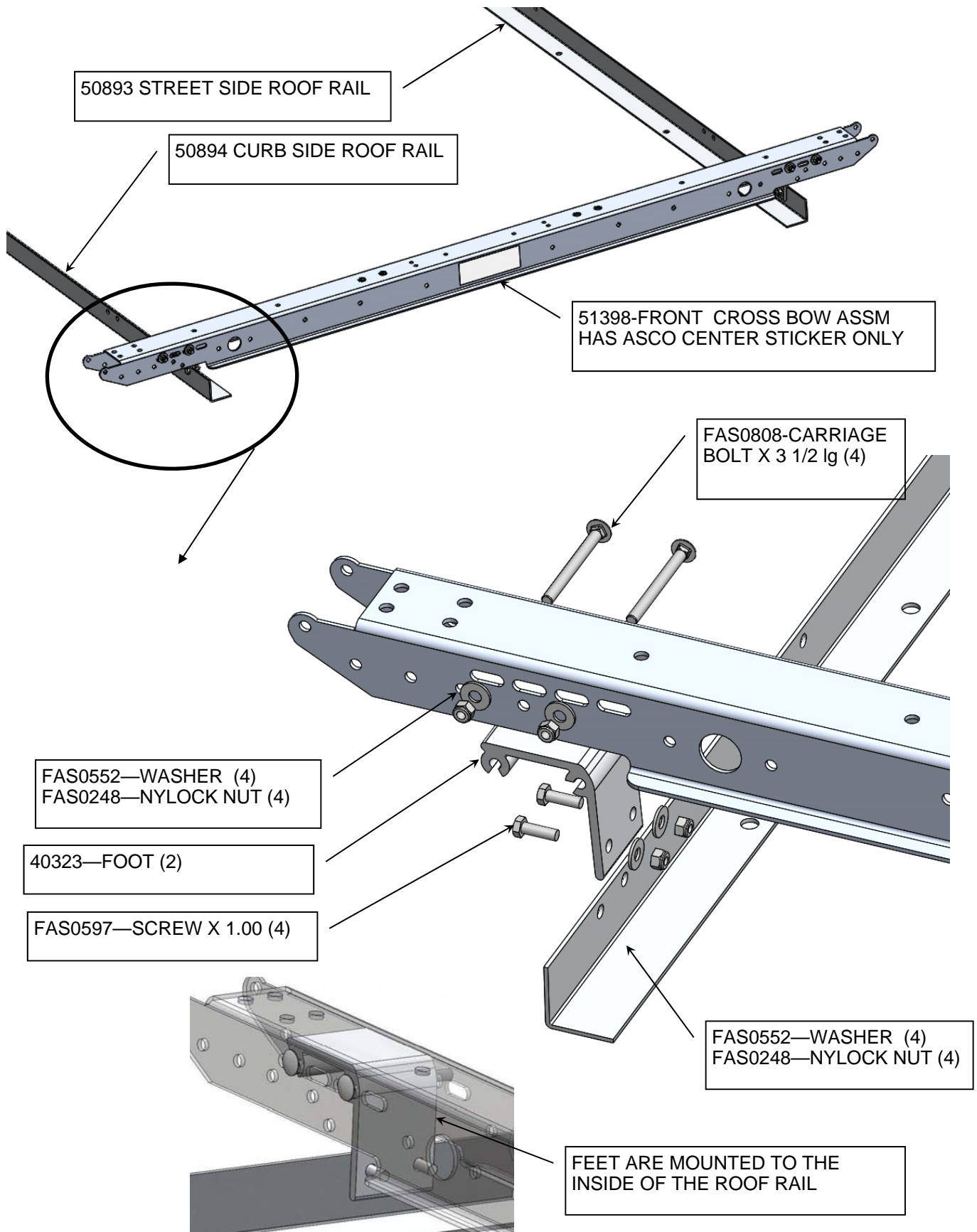



**STEP #4 : FOLLOWING THE DROP DOWN INSTURCTIONS,
ASSEMBLE WHAT YOU CAN PRIOR TO INSTALLING ON THE VEHICLE.
BELOW ARE A FEW EXAMPLES.**

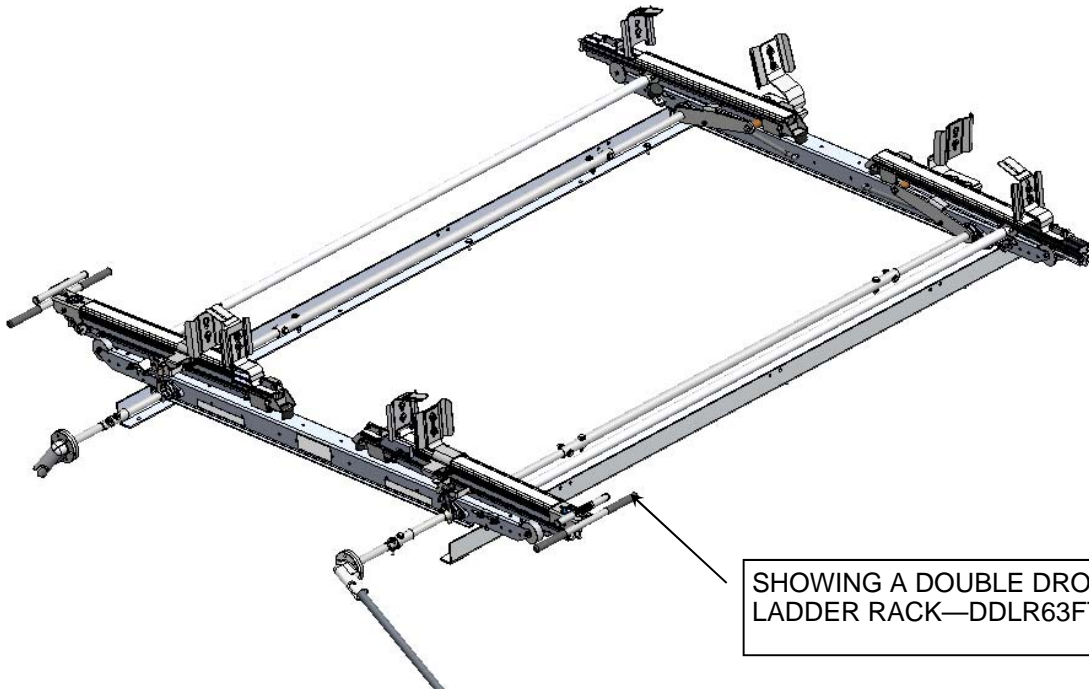

SHOWING A DOUBLE DROP DOWN
LADDER RACK—DDL63FTM

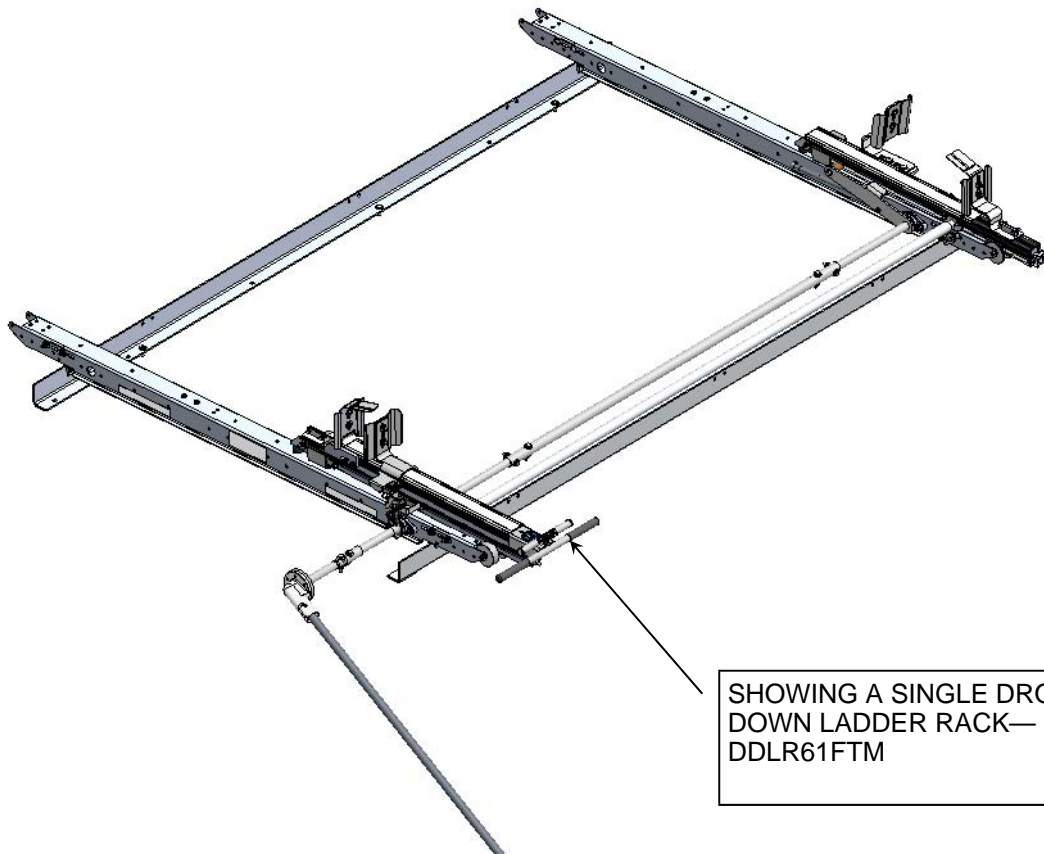

SHOWING A SINGLE DROP
DOWN LADDER RACK—
DDL61FTM

STEP #5 INSTALL RACK ON VEHICLE

REMOVE PLASTIC PLUGS FROM SQUARE DEPRESSIONS ONLY. THESE ARE THE FACTORY MOUNTING POINTS. DO **NOT** REMOVE OTHER PLUGS!! RUN M8-1.25 TAP, FULL DEPTH, TO CLEAN OUT THREADS IN OEM FASTENER IF NECESSARY. MAY HAVE TO REPEAT PROCESS TO GET FULLY CLEAN.

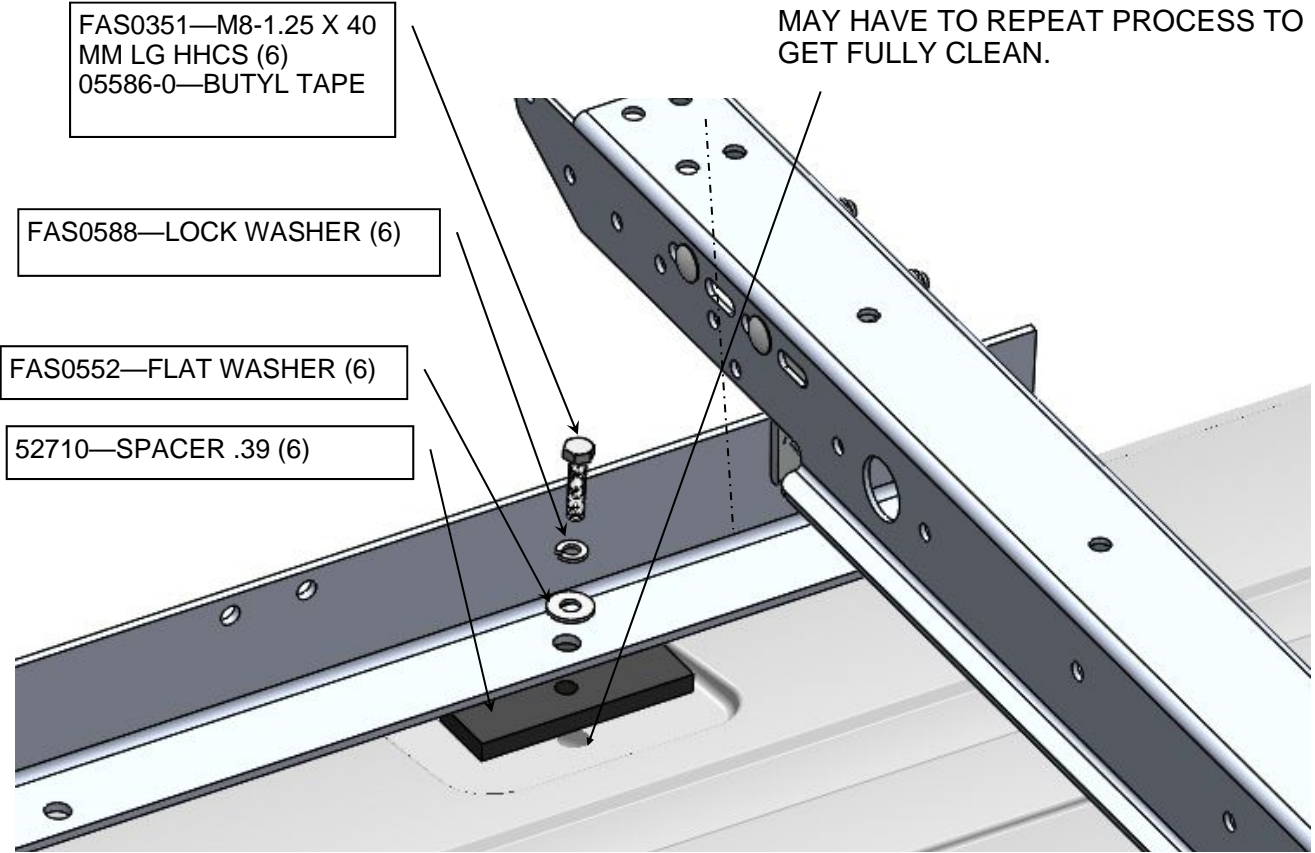

CAREFULLY REMOVE PLASTIC PLUGS FROM FACTORY ATTACHMENT POINTS. NOTE, THEY ARE INSTALLED PRIOR TO VEHICAL BEING PAINTED. IF ROOF CLEARANCE HOLES AND OEM FASTENER ARE MISALIGNED TOO FAR, HOLE IN ROOF SKIN MAY NEED TO BE ENLARGED (AND PRIMERED), AS WELL AS CORRESPONDING HOLE IN ROOF RAIL OF RACK. WRAP SCREWS WITH BUTYL TAPE BENEATH WASHERS, ENOUGH TO FILL HOLE IN RAIL. PUSH SCREWS THRU FOAM, AND RUBBER PAD,ADD ENOUGH SILICONE TO FILL EACH CAVITY. INSTALL SCREWS AND WASHERS AS SHOWN. TORQUE TO 10 TO 12 FT LBS. TORQUE ALL FASTENERS ON RACK ITSELF TO 10-12 FT LBS. DO NOT OVER-TORQUE AS THESE ARE STAINLESS STEEL FASTENERS!

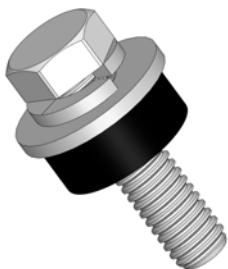

MOUNTING SCREW WITH WASHERS AND BUTYL TAPE BEFORE INSTALLATION (LEFT) AND WHAT IT SHOULD LOOK LIKE AFTER INSTALLATION (RIGHT).

