



PRODUCT WEIGHT

**94 lbs**

WIDTH x DEPTH x HEIGHT

**77"X106"X18"**

CAPACITY

**28 FOOT EXT**

COLOR

**Aluminum / Black**

CATALOG NUMBER

**DDL61NVH**

*PRODUCT FEATURES*

This drop down rack and roof cross-bow kit is designed to fit the Nissan high roof, standard wheel base. The drop down will carry 20 to 28 foot extension ladders, and 10-12 foot step ladders. Step ladders shorter than 10' require DDLRSLKHR step ladder kit. Step ladders wider than 26" at the base require the wide step ladder add on, part 57107. Ladders with extensive gussets or platform step ladders may not be compatible with the rack.

The cross-bow kit is secured to the Nissan NV Cargo by OEM supplied fastening points.

SEE PAGE 2 FOR APPLICATION NOTES AND ACCESSORIES, OTHER PRODUCTS THAT WORK WITH THIS UNIT.

**CATALOG NUMBER      **DDL61NVH*******PRODUCT APPLICATION***

**This Drop down unit is designed to fit 2016 and newer Nissan NV Cargo high roof vehicles.**

***ACCESSORIES THAT WILL WORK WITH THIS PRODUCT******CATALOG NUMBER******DESCRIPTION*****DDL61SLKHR      STEP LADDER KIT, DDL61 HR****DDL61HSS      HIGH ROOF LADDER RACK SS ( CONVERT TO DBL)****57107      DDL61 WIDE STEP LADDER KIT-ADD ON PIECE*****SPECIAL APPLICATION NOTES***

**Introduction / Comments:**

Installation instructions for DDLR61HCS and DDLR61HSS. NOTE: This is for high roof vehicles only

**Note:**

It is advised that all fasteners used in this assembly and installation should be checked for tightness at the following intervals: @ 2-weeks and again @ 6-weeks of operation. This preventive maintenance step must be completed to ensure your Product gives you long service life.

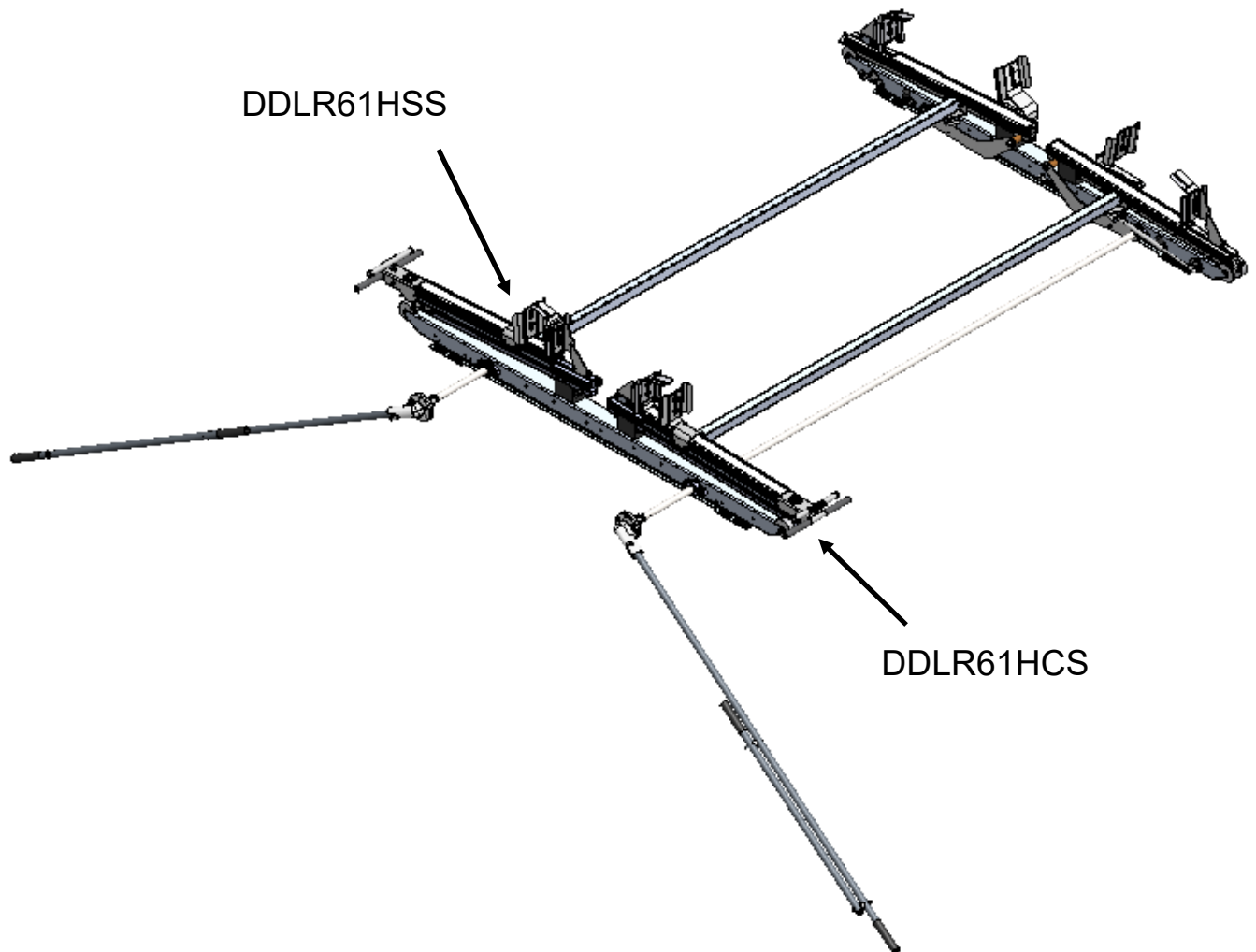

**DDL61HCS / DDL61HSS  
SINGLE DROP DOWN LADDER RACK  
CURB AND STREET SIDE, HIGH ROOF VANS W/  
HANDLE EXT.**

## - PRECAUTIONS -



**CAUTION**  
THE USE OF AIR IMPACT TOOLS CAN  
OVER-TORQUE FASTENERS AND  
CAUSE FASTENER FAILURE!



**CAUTION**  
ALL INSTALLATION HOLES SHOULD BE SEALED  
WITH SILICON OR BUTYL SEALANT TO PREVENT  
EXHAUST FUMES FROM ENTERING THE VEHICLE!



**DANGER**  
INSPECT FOR FUEL TANK, FUEL LINES, BRAKE LINES, HIGH  
VOLTAGE BATTERIES AND ELECTRICAL LINES PRIOR TO  
DRILLING TO AVOID DAMAGING CRITICAL VEHICLE SYSTEMS  
OR INJURY TO INSTALLER DURING INSTALLATION PROCESS!

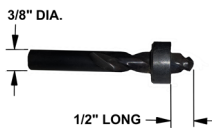

**CAUTION**  
TO AVOID DAMAGING THE VEHICLE ALWAYS USE DRILL  
STOPS WHEN DRILLING ANY INSTALLATION HOLES!  
ADRIAN AVAILABLE PART #'S 31119-0 (3/8" X 1/2"  
DEEP), 31121-0 (1/2" x 1/2" DEEP)



## - IMPORTANT WARRANTY REQUIREMENTS -

1. SUBSTITUTING ADRIAN STEEL SPECIFIED FASTENERS FOR ASSEMBLY AND/OR INSTALLATION WILL VOID YOUR PRODUCT WARRANTY.
2. ALL HOLES DRILLED INTO VEHICLE SHOULD HAVE THE RAW METAL EDGES SEALED WITH A SELF-ETCHING PRIMER TO RESIST CORROSION AND POTENTIAL FASTENER POINT FAILURE.
3. ALL FASTENERS USED IN THE INSTALLATION OF THIS PRODUCT SHOULD BE TIGHTENED TO THE TORQUE(S) SPECIFIED IN THESE INSTRUCTIONS.
4. THESE INSTRUCTIONS SHOULD BE KEPT WITH THE VEHICLE.

### THE BASIC TOOLS NEEDED FOR MOST INSTALLATIONS



DRILL

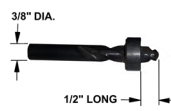

DRILL BIT WITH  
STOP

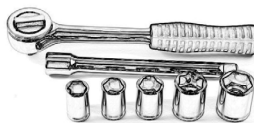

RATCHET, SOCKETS  
AND/OR WRENCHES



SCREWDRIVERS



MEASURING TAPE

ADDITIONAL TOOLS MAY BE NEEDED FOR THIS INSTALLATION AND THEY WILL BE IDENTIFIED IN THE STEPS THAT FOLLOW.

If your vehicle contains carpet or a rubber floor mat you will need to prepare the mounting location. Position the product to be installed into the vehicle and once you are satisfied with the mounting locations, mark the mounting locations. Using a 1-3/16" diameter carpet cutter (P/N: 31183-0). Select the appropriate floor spacers as shown in the illustration. Set those aside for use later into the installation process. Using the correct drill bit size for the selected plusnut, drill the mounting holes in the vehicle sheet metal to prepare for installing the plusnuts. If you are thru-bolting at any of the locations simply drill a hole that is 1/16" larger than the bolt size(s) for those locations. Once you have drilled the holes into the vehicle, the raw metal edges should be sealed using a self-etching primer to resist corrosion and potential fastener point failure.

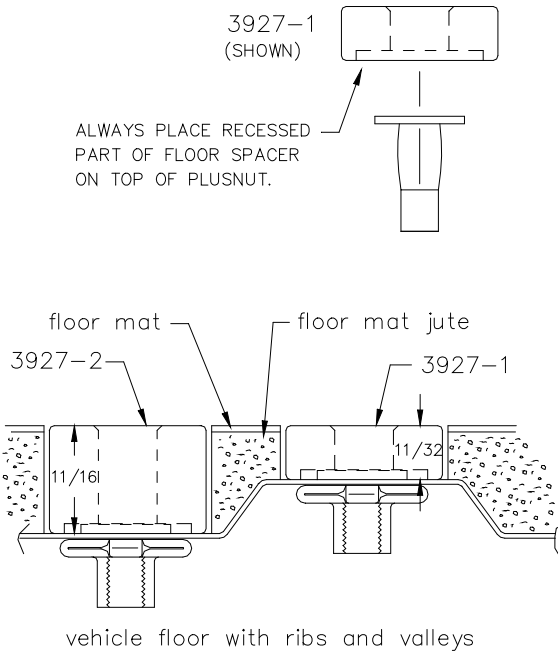

A PLUSNUT (RIVNUT) SETTING TOOL IS REQUIRED FOR PLUSNUT (RIVNUT) INSTALLATION . PLUS NUT SETTING TOOL CAN BE ORDERED THROUGH ADRIAN STEEL, OR USE AN AIR POWERED PLUSNUT SETTING GUN.

1/4-20UNC Plusnut (FAS0052) Use 3/8" dia. drill w/stop  
 FAS0080 SCREW, HXHD, 1/4-20UNCx2.00", G8  
 FAS0067 WASHER, FLAT, 1/4"ID  
 22200-0 PLUSNUT TOOL

5/16-18UNC Plusnut (FAS0091) Use 1/2" dia. drill w/stop  
 FAS0095 SCREW, HXHD, 5/16-18UNCx2.00", G8  
 FAS0086 WASHER, FLAT, 5/16"ID  
 22200-0 PLUSNUT TOOL

Place barrel of the plusnut body in sheet metal thru hole until flange is flush with sheet metal. Using a 9/16" combination wrench of plusnut tool body and a second hand wrench, ratchet, or air tool, rotate the hex bolt head CW to draw plus nut flanges up (set the plusnut).

**BAG56325  
FASTENER BAG FOR DDLR HIGH ROOF**

ITEM NO.	PART NUMBER	DESCRIPTION	QTY.
1	BAG0509-A	5"X10" 4MIL AUTOBAG	1
2	FAS0811	SCREW,CAP, 5/16-18X3.20 SS	2
3	FAS0248	Nut, Nylon Insert Lock, 5/16-18 SST	36
4	FAS0552	Washer, Flat, 5/16, SST	8
5	FAS0830	Screw, Hex Hd, 5/16-18 X 1.25 SS	6
6	FAS0799	Screw, Hex Hd, 5/16-18x0.75 SS	14
7	34927-0	Ball Stud, Damper	8
8	FAS0588	Washer, Lock, Split, 5/16, SS	4
9	FAS0246	Washer, Flat, 3/8, HRD, ZN	6
10	FAS0110	Nut,Hex Nylk 3/8-16 SS W	4
11	FAS0572	Screw, Button Hd Hex Soc, 3/8-16x1.00 NI-ZN	2
12	FAS0286	SCREW, HHCS, 3/8-16x4, SS	2
13	FAS0035	BOLT,SQ HD,5/16-18X1.0 SS	4
14	FAS0242	Screw, Hex Hd, 5/16-18x1.50 Stainless Steel	5
15	56098	BUMPER STUD, 1" X 1", HR	2
16	34922-0	HOLDER, TOOL, LOAD RATED	1
17	34921-0	CLAMP, CABLE, LOOP, 1.5" ID	1
18	FAS0287	COTTER PIN, 1/16DIA X 1"LG, SS	2
19	34928-0	CLIP, SPRING, RETAINER, 13mm	8

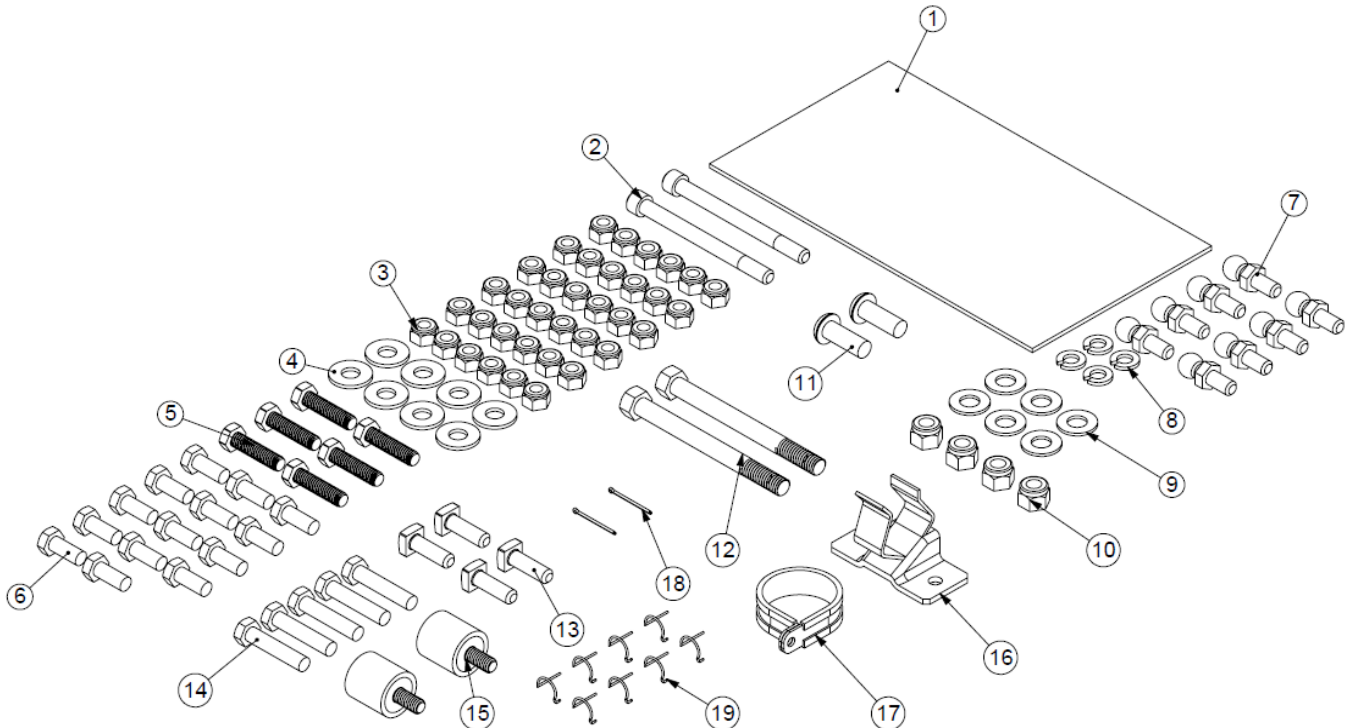

**Step 1CS** Fasten driveline bearings to crossbows. Rear crossbow should have bearings on inside and outside of crossbow. The front crossbow should have one bearing facing the center of the ladder rack.

REAR CROSSBOW

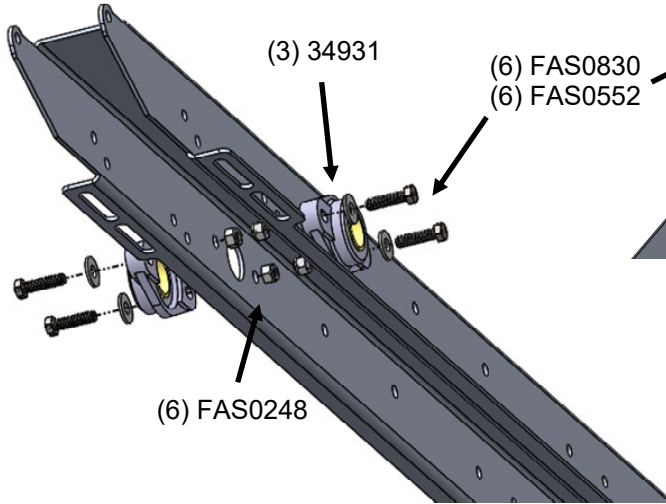

NOTE: This is the inside of the crossbow.

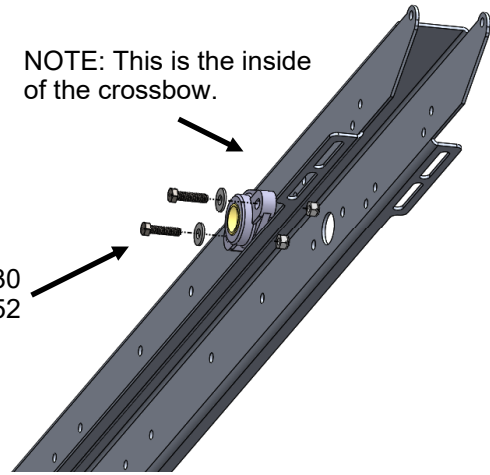

FRONT CROSSBOW

**Step 1SS** To mount to the streetside you follow the same rules as with the curbside; two bearings on the rear crossbow and one on the front, facing the inside of the ladder rack.

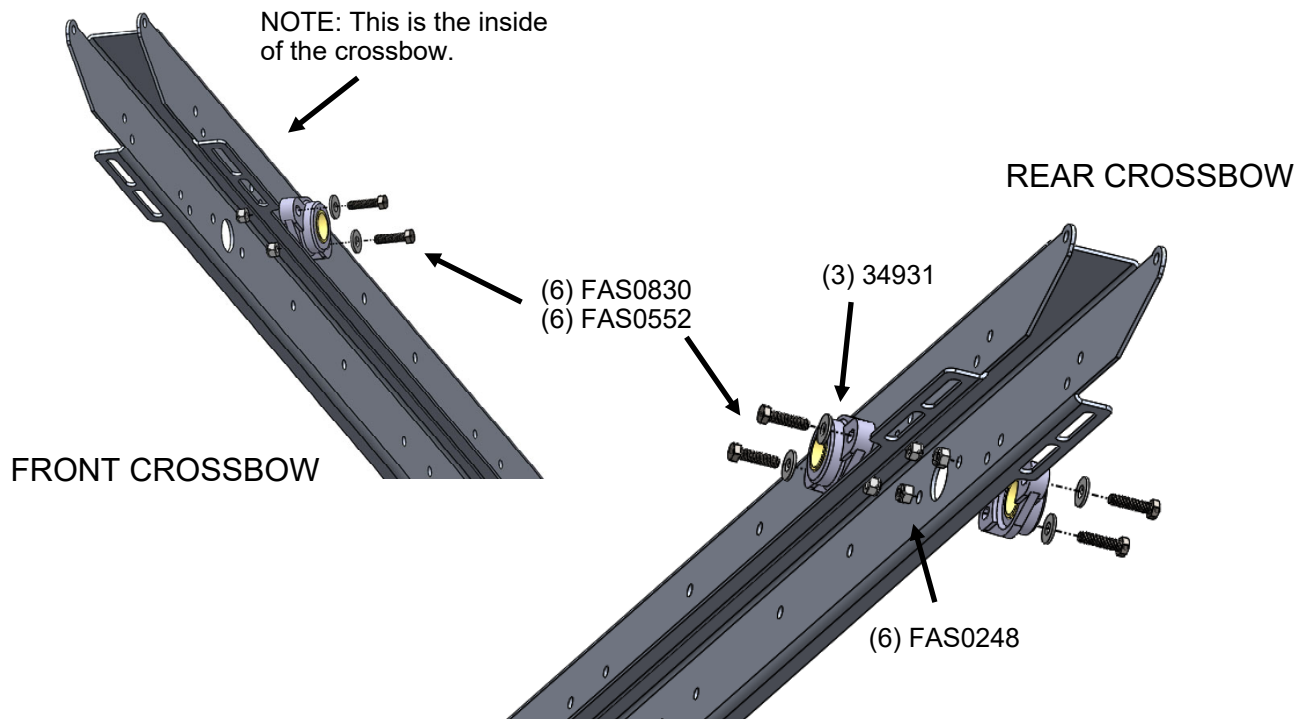

**Step 2CS / 2SS** Attach damper brackets and bumper to the inside of the front and rear crossbows. This step is the same for a curbside and streetside facing drop down.

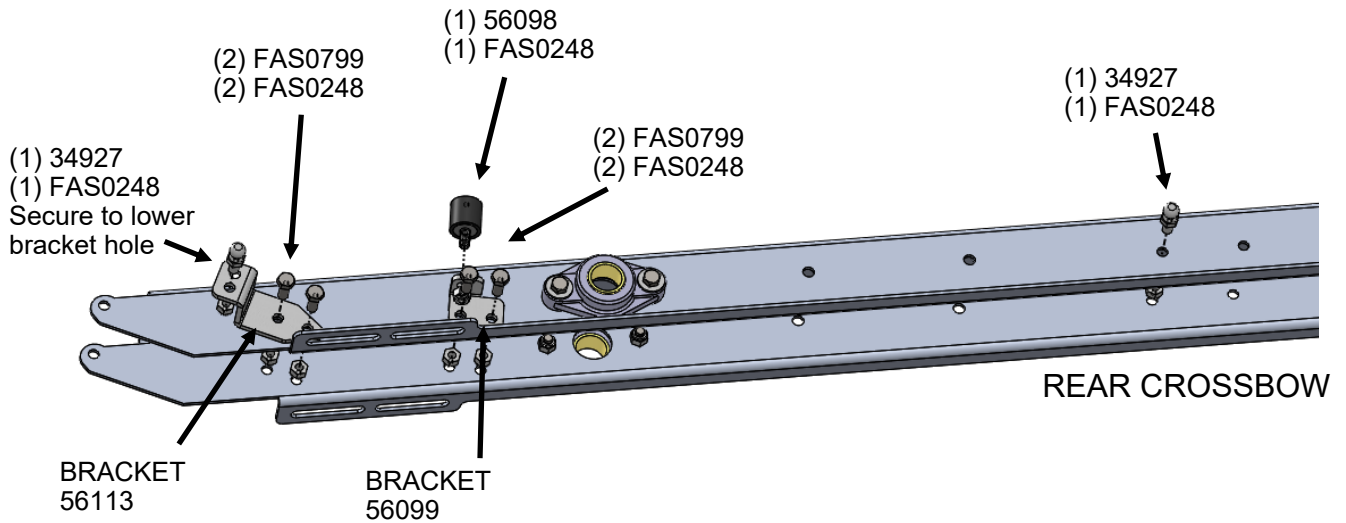

THIS STEP IS MIRRORED FOR FRONT AND REAR CROSSBOWS

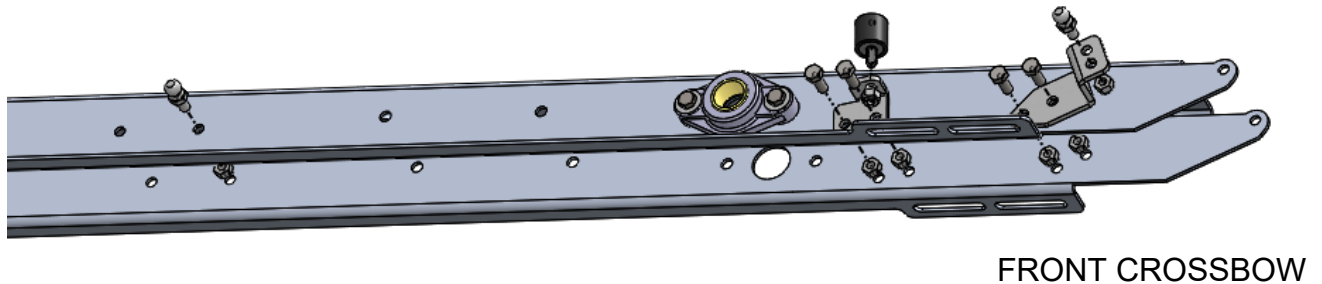



**Step 3CS / 3SS** Fasten capture bracket to the front and rear crossbows, use the set of rivnuts closest to the application side of the van. Also attach the stationary backstop on the front crossbow only.

**IF USING THIS STYLE, ENSURE THE REST FLANGE IS MOUNTING FACING TO THE OUTSIDE OF THE LADDER RACK! THIS WILL GIVE CLEARANCE FOR A CONDUIT KIT TO BE MOUNTED IN THE CENTER.**

**NOTE: ITEM 54178 WILL VARY APPEARANCE AS EITHER VIEW SHOWN BELOW.**

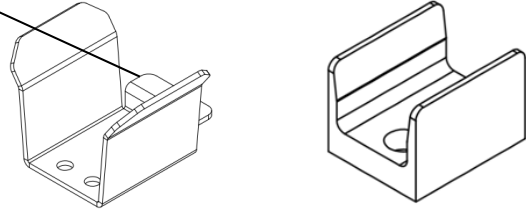

(2) FAS0588  
(2) FAS0799

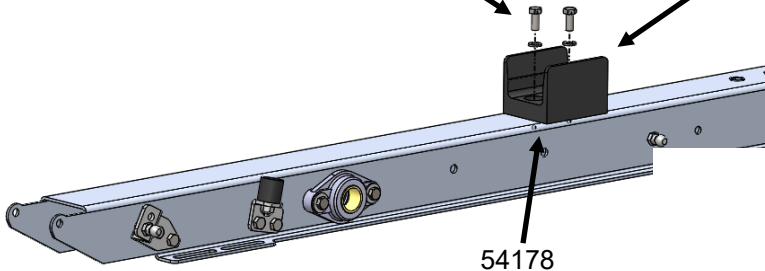

NOTE: Backstop assembly may need to be adjusted later depending on the ladder carried.

REAR CROSSBOW

FRONT CROSSBOW

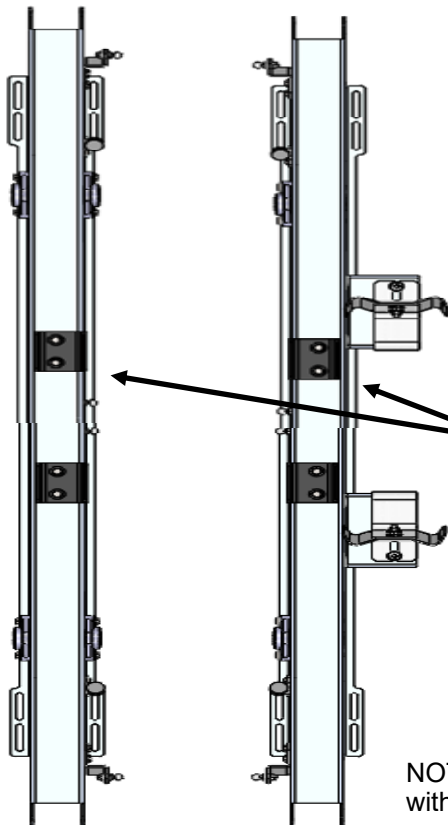

(2) FAS0572  
(2) FAS0246

(2) FAS0799  
(2) FAS0552

(2) FAS0110

(2) FAS0248

NOTE: The wider side of the capture bracket goes toward the inside of the ladder rack for both front and rear.

FRONT CROSSBOW

NOTE: This is an overhead view with both curbside and streetside components on the crossbows.

**Step 4CS / 4SS** Fasten drop down rollers to the side of the crossbow you are using to access your ladder rack. Curbside or streetside.

NOTE: This is curbside orientation.

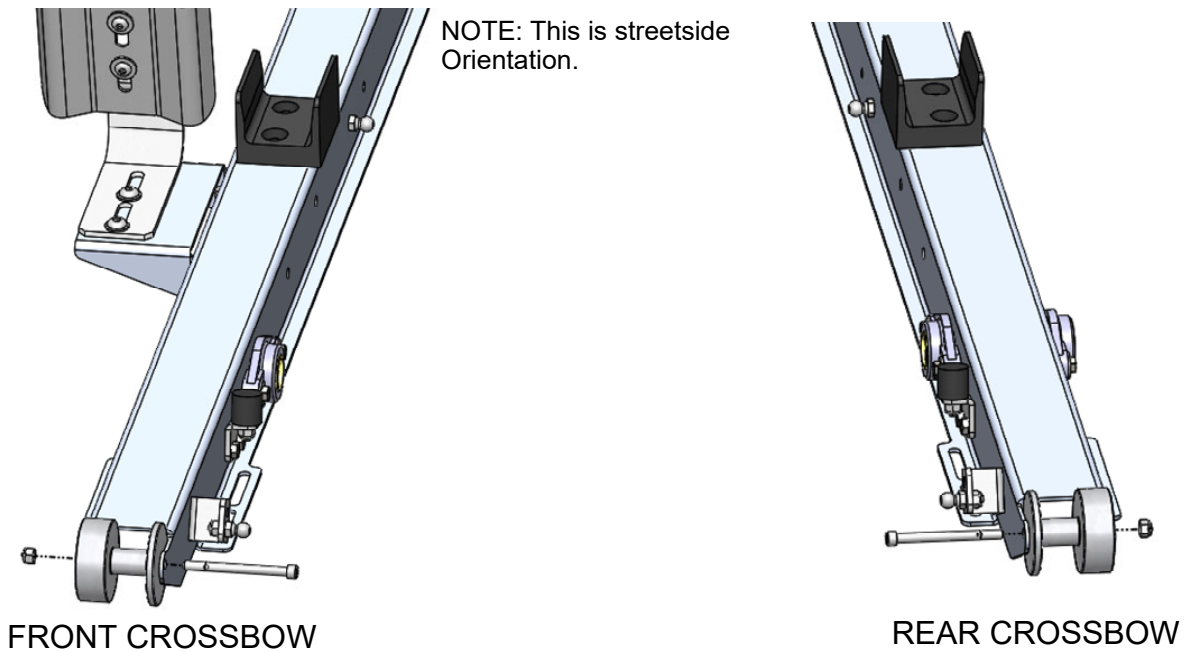
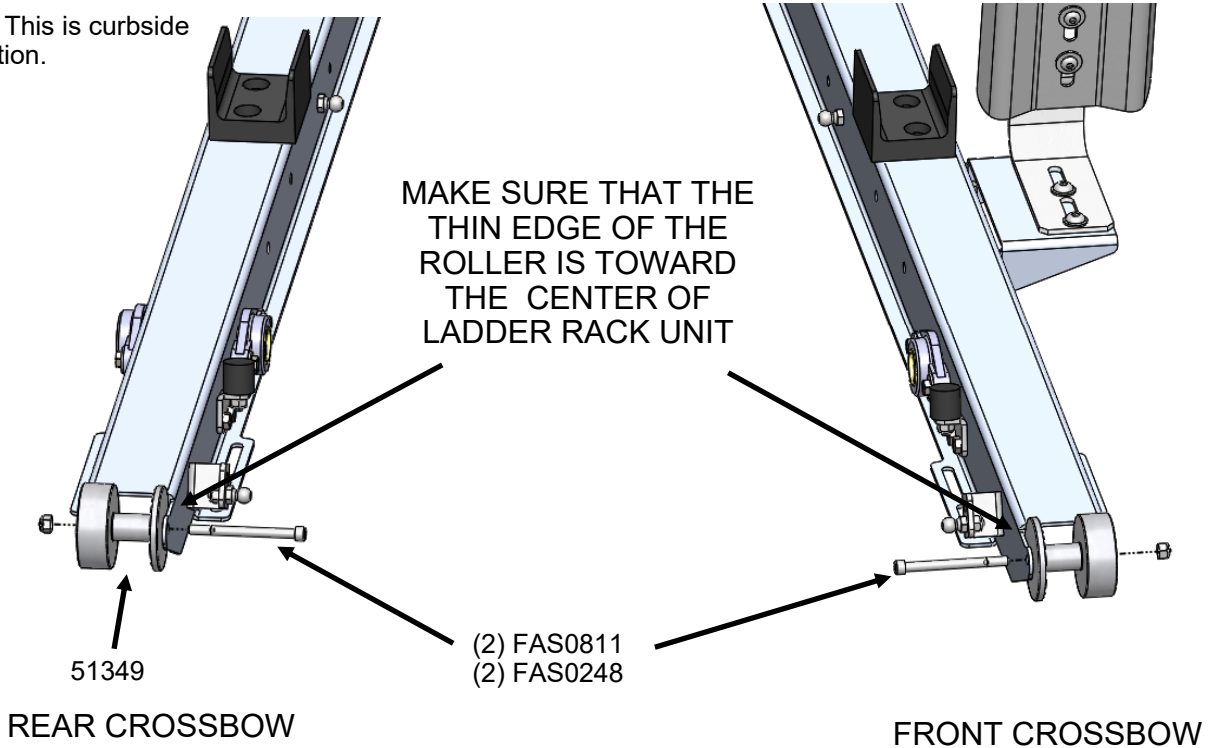

**Step 5CS / 5SS** Attach damper bolts to the driveline. NOTE: the fasteners labeled (A) go outward of the ladder rack and the fasteners labeled (B) face inward on the ladder rack

NOTE: This is curbside orientation.

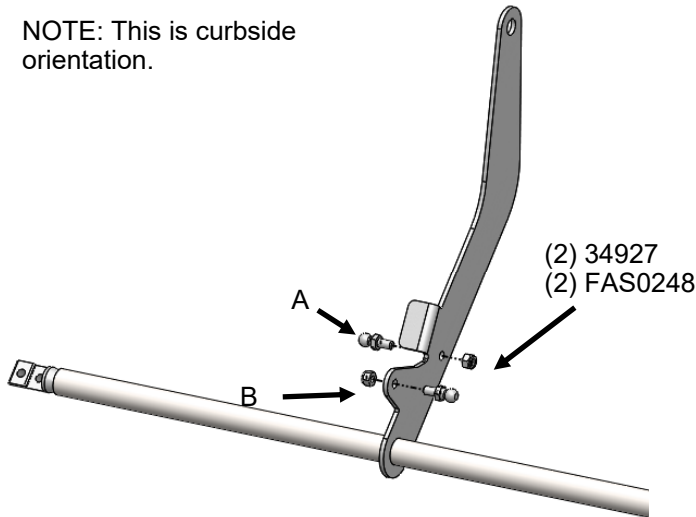

DRIVELINE TOWARDS REAR OF VAN

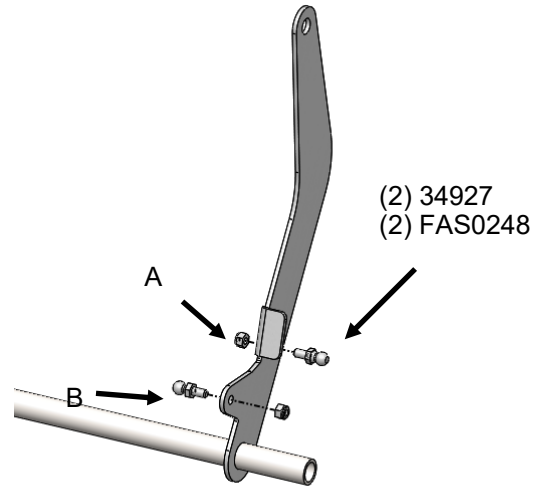

DRIVELINE TOWARDS FRONT OF VAN

NOTE: This is streetside orientation.

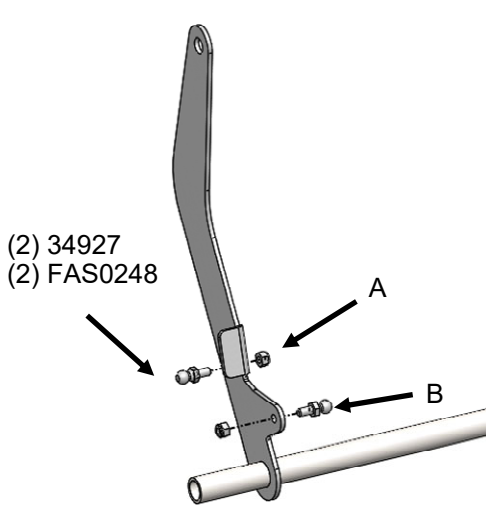

DRIVELINE TOWARDS FRONT OF VAN

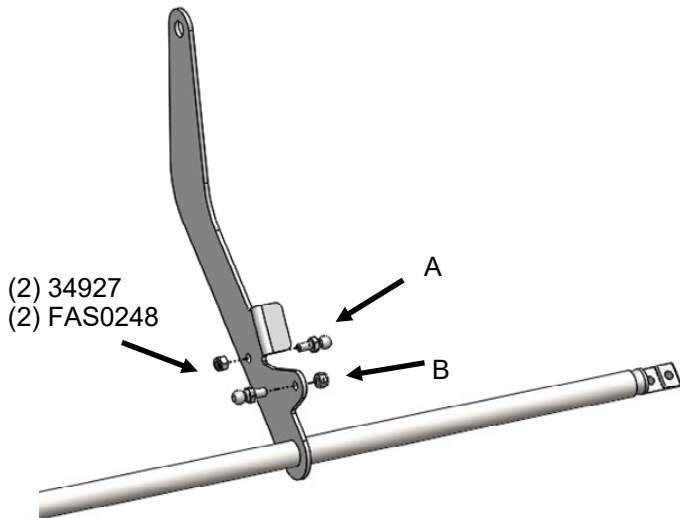

DRIVELINE TOWARDS REAR OF VAN

**Step 6CS / 6SS** First, fasten the rear crossbow to the roof rails on the van (a) and slide the driveline through the rear crossbow bearings (b). Then, set the front driveline into the bearing on the front crossbow (c) and attach the front crossbow to the van's roof rails (d). If you are assembling a double DDLR unit, these steps MUST be done at the same time.

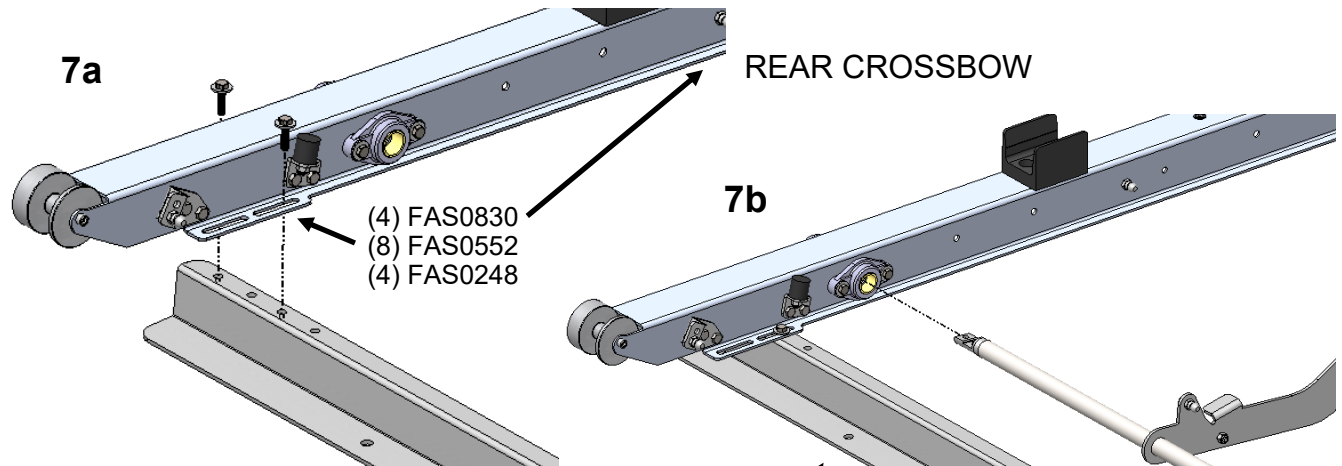

NOTE: This is a Ford Transit rail kit depicted. If your van is not a Ford Transit you will have a different rail kit. Refer to your rail kit instructions for crossbow placement, fasteners and fastening holes.

7b

NOTE: The longer, notched end of the driveline must go into the rear crossbow for both curbside and streetside units. This is for the handle to be used.

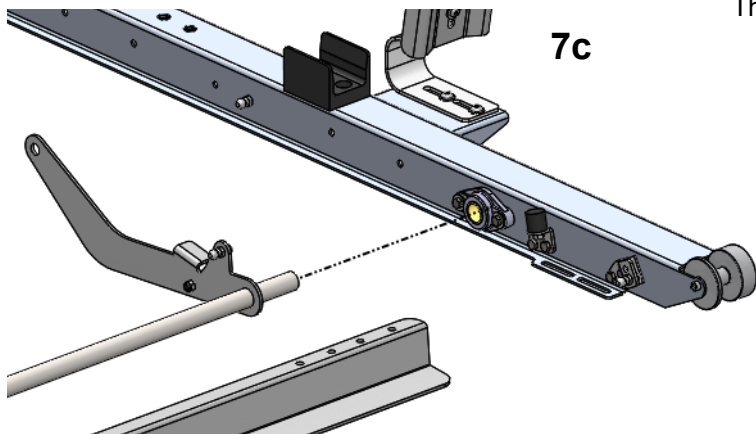

7c

NOTE: These pictures are for a curbside assembly, but the steps are simply mirrored for a streetside one.

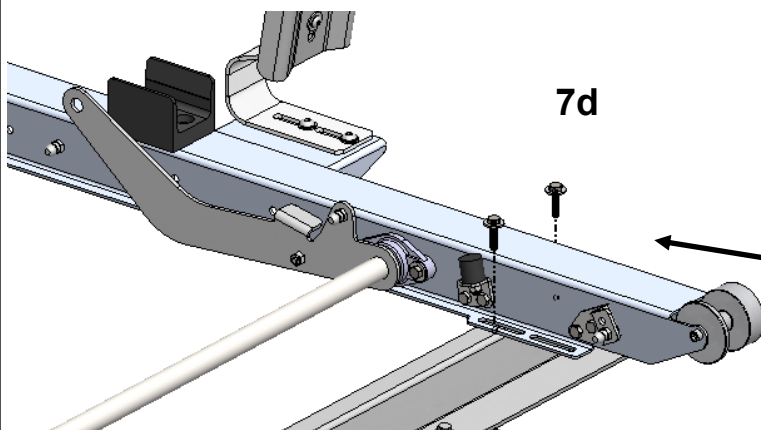

7d

(4) FAS0830  
(8) FAS0552  
(4) FAS0248

**Step 7CS / 7SS** Attach dampers to the rounded bolt heads. Use the damper's pins to secure the dampers to their bolts. Be sure that you distinguish between the long and short dampers during assembly.

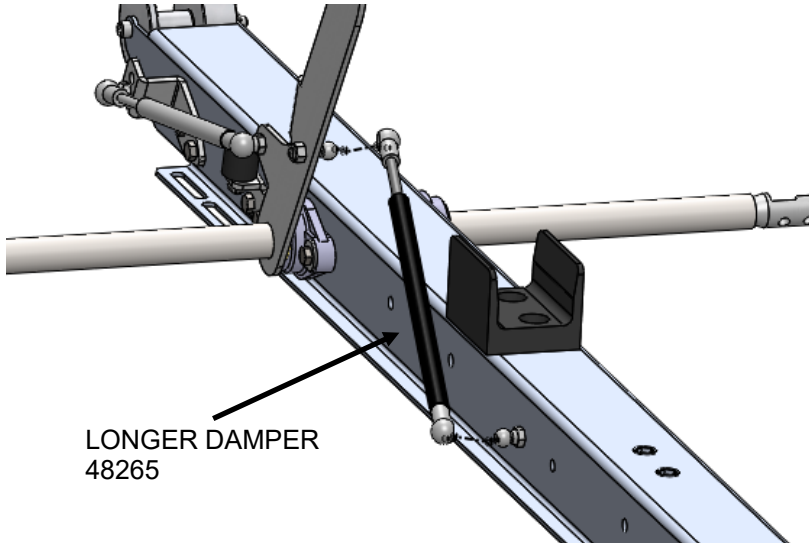

NOTE: Only the rear crossbow and dampers are shown, however this is mirrored onto the front crossbow as well.

REAR CROSSBOW

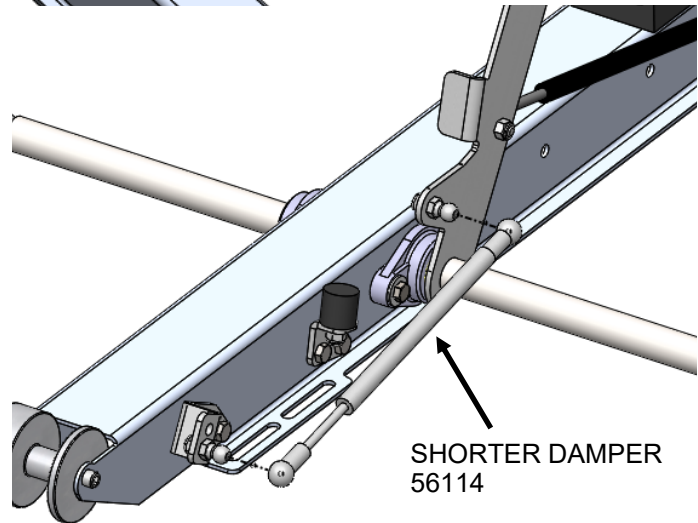

NOTE: While this is a curbside unit image, the same steps must be followed for a streetside unit.

NOTE: Use the damper's pins to secure onto rounded bolts.

OPEN (8) 34928-0

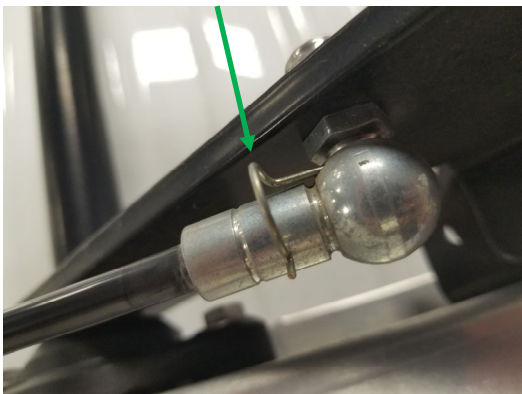

CLOSED



**Step 8CS / 8SS** Fasten drop down assemblies to the driveline and set them into the rollers on the end of each crossbow. Be sure that the primary drop down unit (with handle) is towards the rear of the van, in both streetside and curbside assemblies.

NOTE: This is curbside orientation.

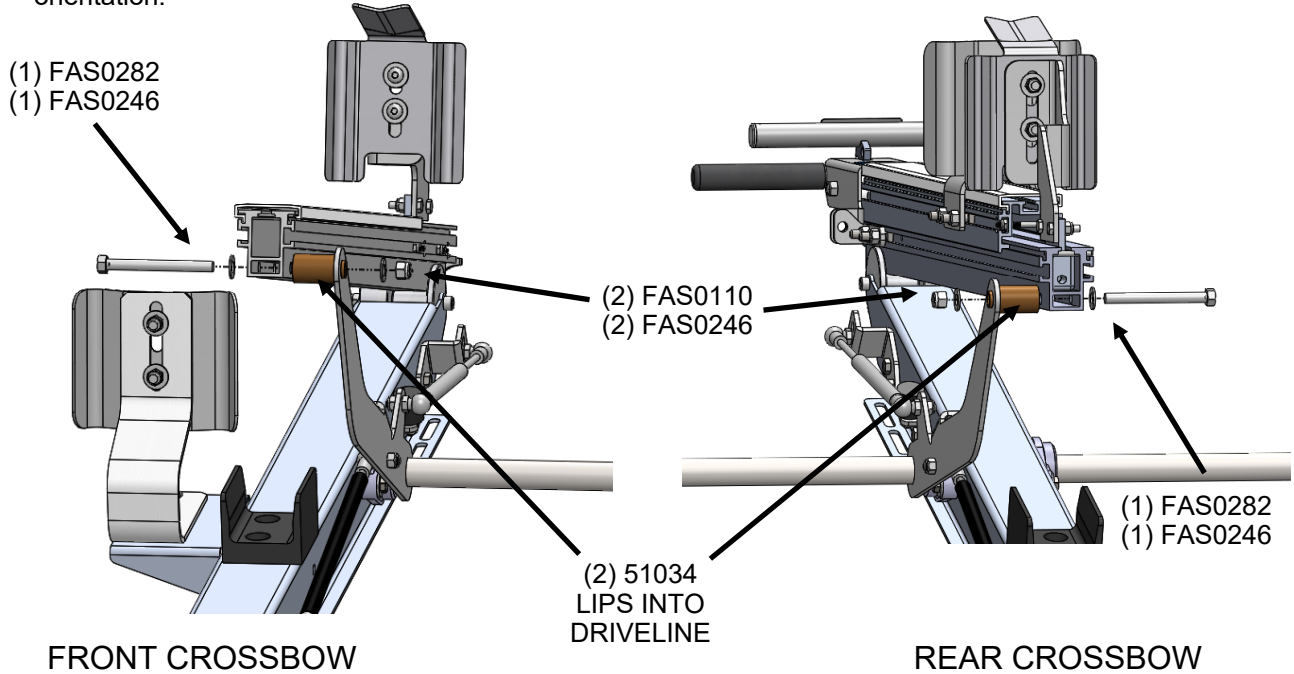

NOTE: This is streetside orientation.

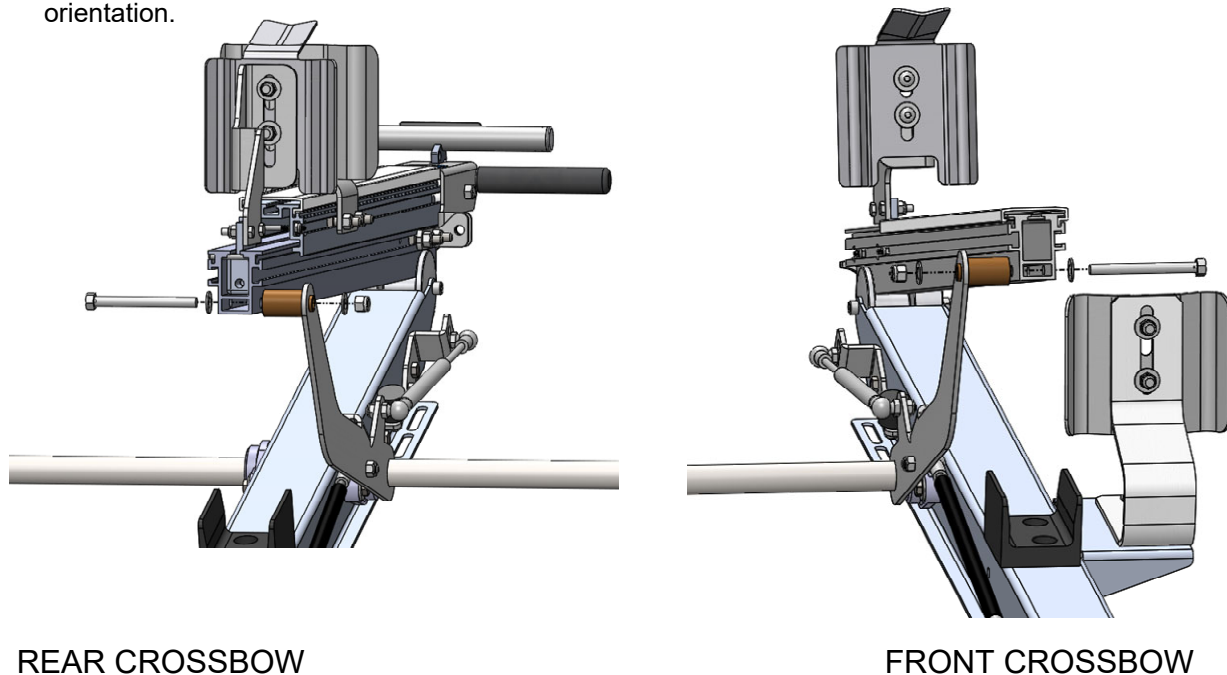

**Step 9CS / 9SS** Attach crossbeam to each drop down slide. The FAS0035 go into grooves on the drop down extensions. NOTE: The distance from the top of the slide to the crossbeam should be 11.5 inches.

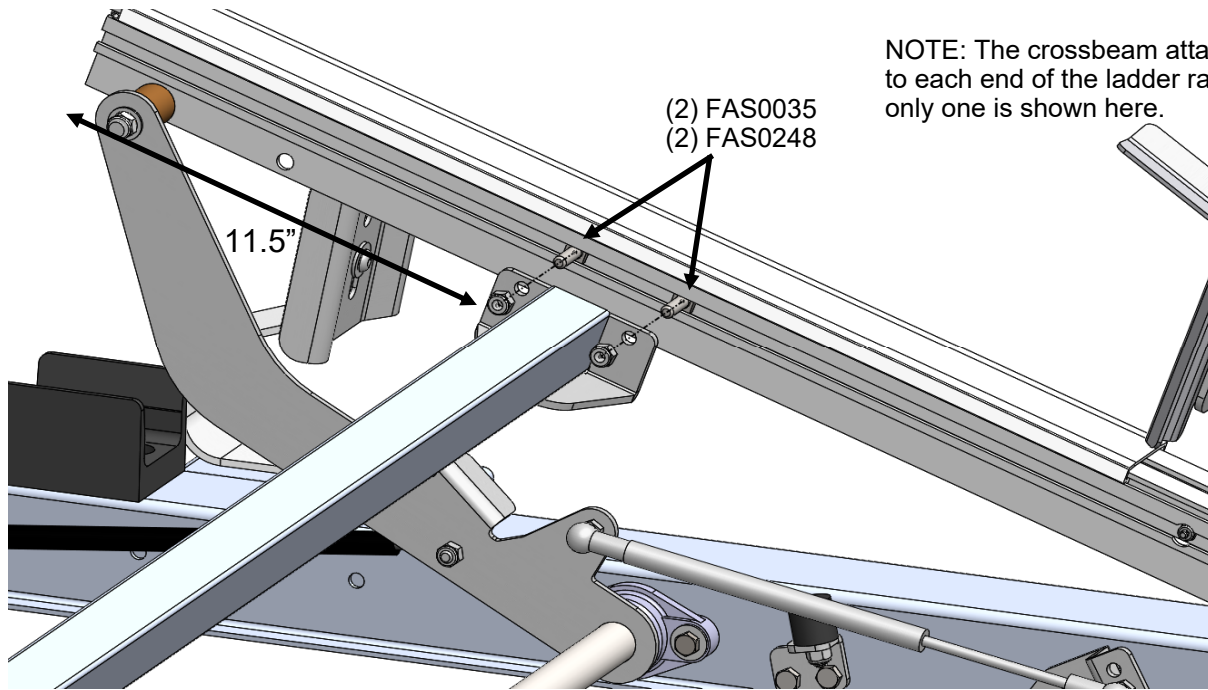

**Step 10CS / 10SS** Fasten circular handle connector to the driveline. There will be one of these connections for both curbside and streetside units.

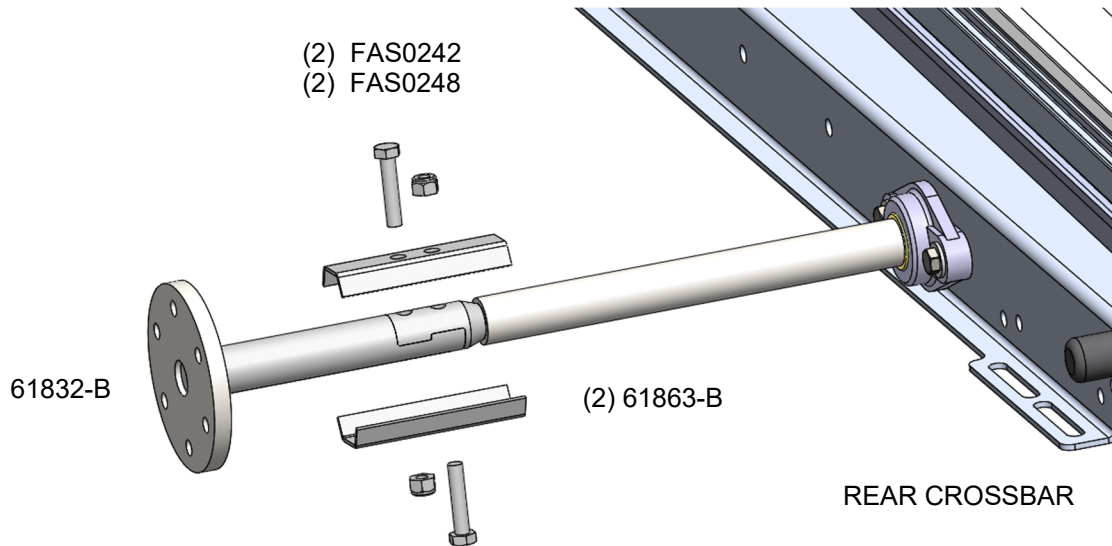

**Step 11CS / 11SS** Attach handle casting to the driveline. This orientation will be affected by a curbside and streetside unit.

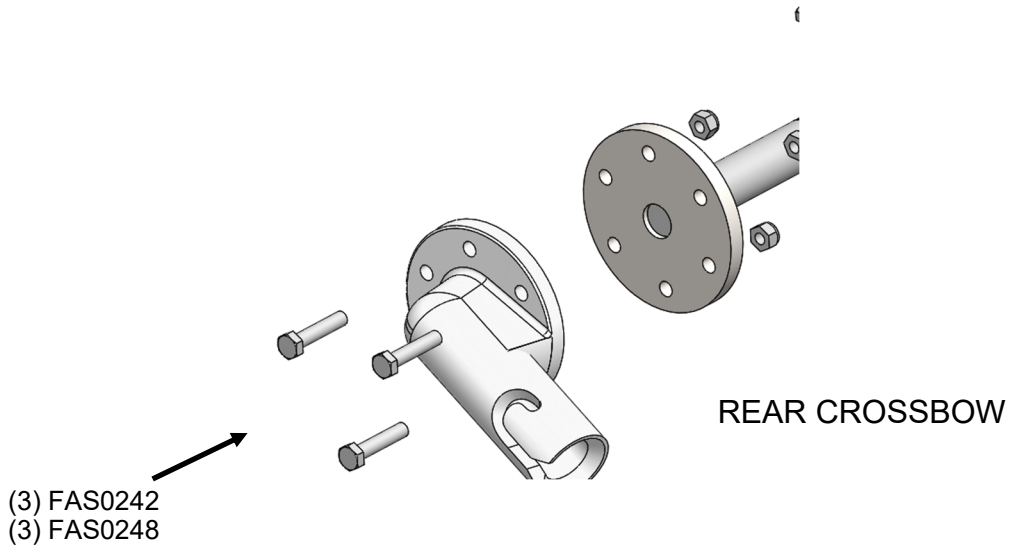

CS VIEW

SS VIEW

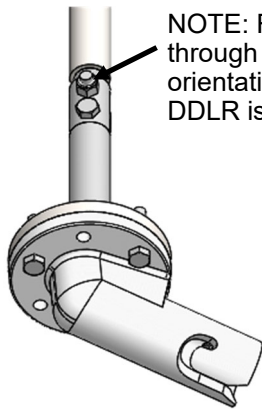

NOTE: Fasteners are vertical through the driveline. This driveline orientation is achieved when the DDLR is in the stowed position.

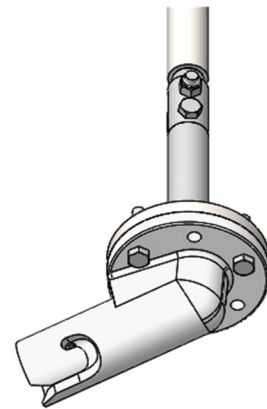

NOTE: This is the orientation required for the driveline handle to be properly positioned. The newly attached casting should be one hole off of vertical with the driveline in the counter-clockwise direction.

NOTE: This is the orientation required for the driveline handle to be properly positioned. The newly attached casting should be one hole off of vertical with the driveline in the clockwise direction.



**Step 12CS / 12SS** Optional, stow the pivot handle.

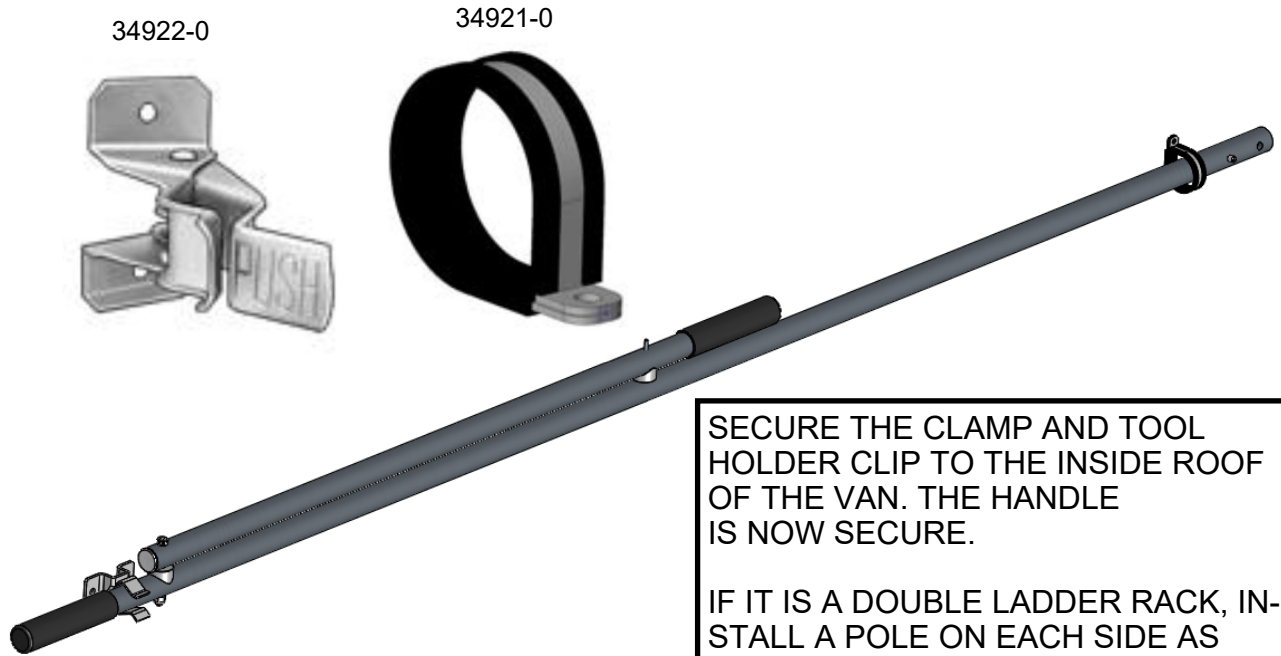

SECURE THE CLAMP AND TOOL HOLDER CLIP TO THE INSIDE ROOF OF THE VAN. THE HANDLE IS NOW SECURE.

IF IT IS A DOUBLE LADDER RACK, INSTALL A POLE ON EACH SIDE AS SHOWN.

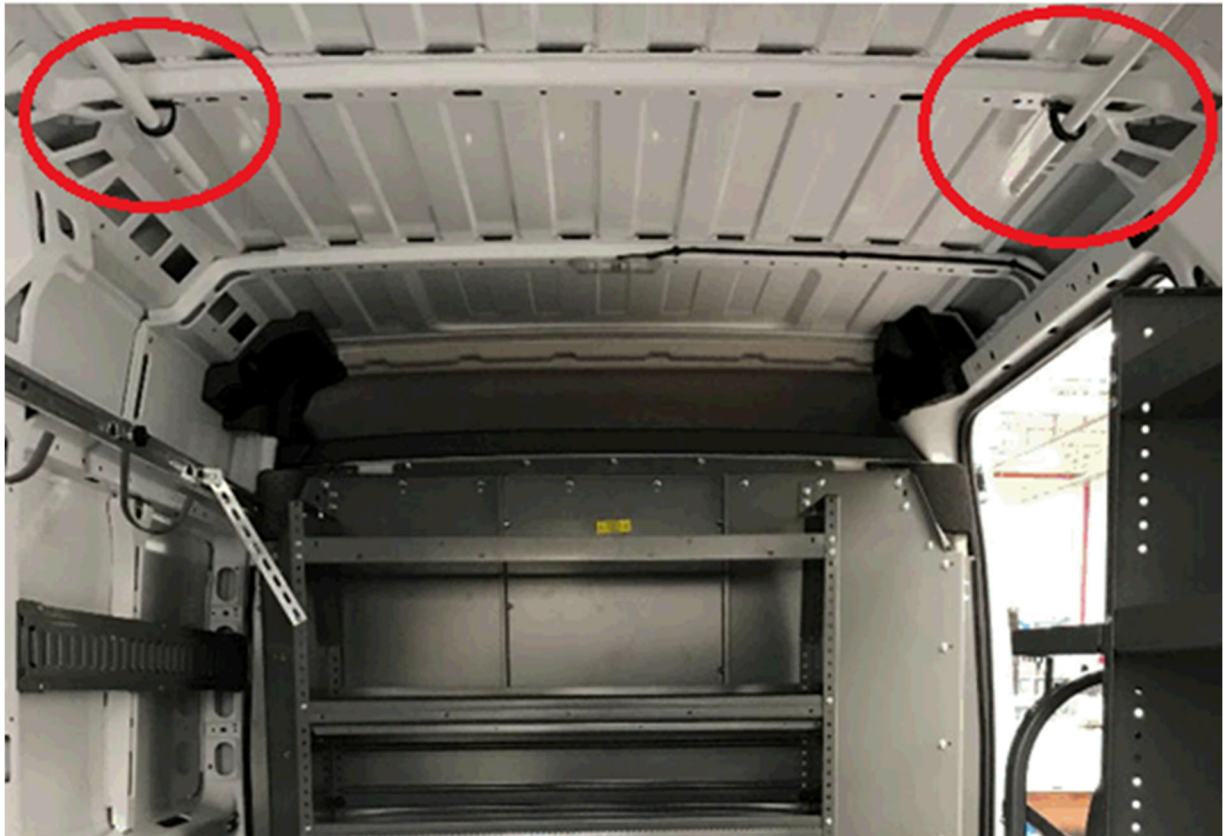

**Step 13CS / 13SS** Your drop down installation is now complete.



NOTE: As stated previously, this view contains a Ford Transit roof rail kit. If your vehicle is not a Ford Transit you will have a different roof rail kit. However, the drop down units will stay the same.

**DOUBLE CHECK ALL FASTENERS LOCATIONS TO BE SURE THAT ALL  
FASTENERS ARE TIGHTENED TO SPECIFICATIONS.  
YOUR INSTALLATION IS NOW COMPLETE!  
STOW THIS COPY IN THE VEHICLE FOR FUTURE REFERENCES!**

**REAR CLAMP PAD MOVES TOWARDS CURB TO  
TIGHTEN LADDER TO RACK**

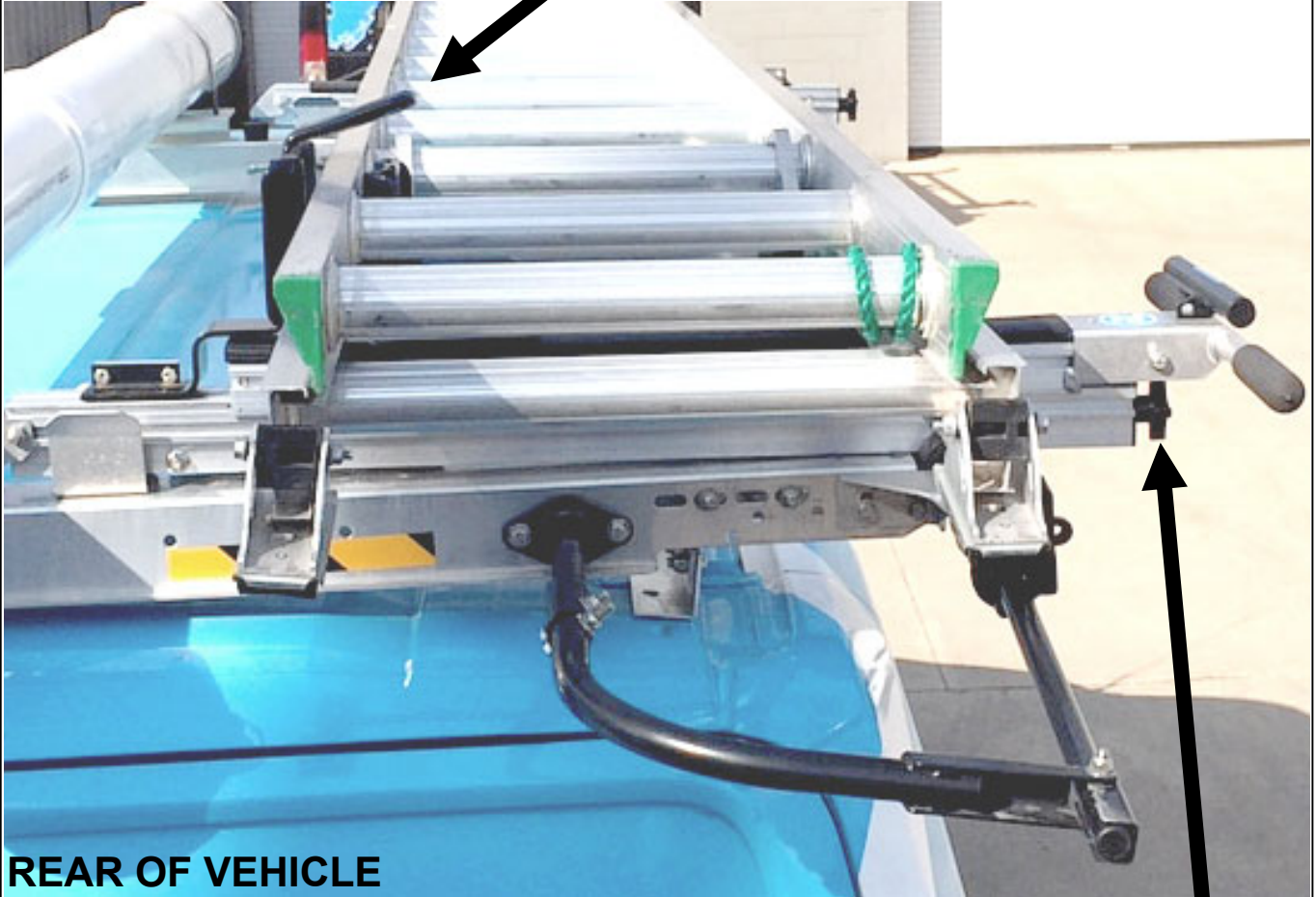

**REAR OF VEHICLE**

**TURN KNOB TO ADJUST TO  
YOUR LADDER.**

**DO NOT OVER TIGHTEN!  
CLAMP PAD SHOULD JUST  
TOUCH THE LADDER.**



**FRONT CLAMP PAD MOVES TOWARDS STREET  
TO TIGHTEN LADDER TO RACK**



**FRONT OF VEHICLE**

**TURN KNOB TO ADJUST TO  
YOUR LADDER.**

**DO NOT OVER TIGHTEN!  
CLAMP PAD SHOULD JUST  
TOUCH THE LADDER.**



**DDL61 Series Final Adjustment Instruction**

**DOUBLE CHECK ALL FASTENERS LOCATIONS TO BE SURE THAT ALL FASTENERS ARE  
TIGHTENED TO SPECIFICATIONS.**

**YOUR INSTALLATION IS NOW COMPLETE!**

**STOW THIS COPY IN THE VEHICLE FOR FUTURE REFERENCES!**

**Introduction / Comments:**

This roof rail and cross bow kit is designed for the Nissan High Roof Van. It is the base unit for all of the ladder rack combinations for the vehicle. The single and double drop down ladder rack.

**Note:**

It is advised that all fasteners used in this assembly and installation should be checked for tightness at the following intervals: @ 2-weeks and again @ 6-weeks of operation. This preventive maintenance step must be completed to ensure your Product gives you long service life.

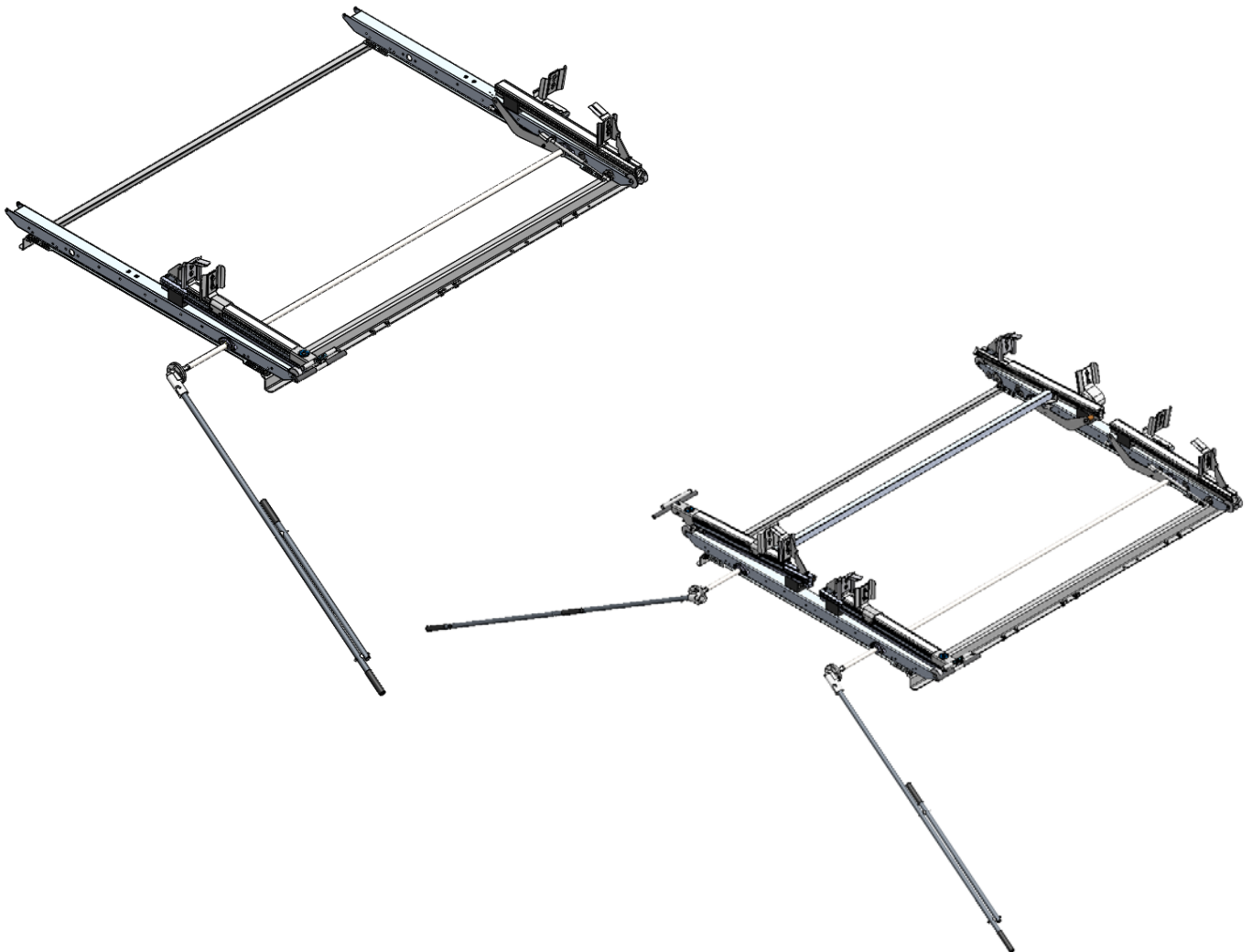

**RRKNVH  
ROOF RAIL AND CROSS BOW KIT  
NISSAN NV CARGO HIGH ROOF VANS**

## - PRECAUTIONS -



**CAUTION**  
THE USE OF AIR IMPACT TOOLS CAN  
OVER-TORQUE FASTENERS AND  
CAUSE FASTENER FAILURE!



**CAUTION**  
ALL INSTALLATION HOLES SHOULD BE SEALED  
WITH SILICON OR BUTYL SEALANT TO PREVENT  
EXHAUST FUMES FROM ENTERING THE VEHICLE!



**DANGER**  
INSPECT FOR FUEL TANK, FUEL LINES, BRAKE LINES, HIGH  
VOLTAGE BATTERIES AND ELECTRICAL LINES PRIOR TO  
DRILLING TO AVOID DAMAGING CRITICAL VEHICLE SYSTEMS  
OR INJURY TO INSTALLER DURING INSTALLATION PROCESS!



**CAUTION**  
TO AVOID DAMAGING THE VEHICLE ALWAYS USE DRILL  
STOPS WHEN DRILLING ANY INSTALLATION HOLES!  
ADRIAN AVAILABLE PART #'S 31119-0 (3/8" X 1/2"  
DEEP), 31121-0 (1/2" X 1/2" DEEP)



## - IMPORTANT WARRANTY REQUIREMENTS -

1. SUBSTITUTING ADRIAN STEEL SPECIFIED FASTENERS FOR ASSEMBLY AND/OR INSTALLATION WILL VOID YOUR PRODUCT WARRANTY.
2. ALL HOLES DRILLED INTO VEHICLE SHOULD HAVE THE RAW METAL EDGES SEALED WITH A SELF-ETCHING PRIMER TO RESIST CORROSION AND POTENTIAL FASTENER POINT FAILURE.
3. ALL FASTENERS USED IN THE INSTALLATION OF THIS PRODUCT SHOULD BE TIGHTENED TO THE TORQUE(S) SPECIFIED IN THESE INSTRUCTIONS.
4. THESE INSTRUCTIONS SHOULD BE KEPT WITH THE VEHICLE.

### THE BASIC TOOLS NEEDED FOR MOST INSTALLATIONS



DRILL



DRILL BIT WITH  
STOP



RATCHET, SOCKETS  
AND/OR WRENCHES



SCREWDRIVERS



MEASURING TAPE

ADDITIONAL TOOLS MAY BE NEEDED FOR THIS INSTALLATION AND THEY WILL BE IDENTIFIED IN THE STEPS THAT FOLLOW.

If your vehicle contains carpet or a rubber floor mat you will need to prepare the mounting location. Position the product to be installed into the vehicle and once you are satisfied with the mounting locations, mark the mounting locations. Using a 1-3/16" diameter carpet cutter (P/N: 31183-0). Select the appropriate floor spacers as shown in the illustration. Set those aside for use later into the installation process.

Using the correct drill bit size for the selected plusnut, drill the mounting holes in the vehicle sheet metal to prepare for installing the plusnuts.

If you are thru-bolting at any of the locations simply drill a hole that is 1/16" larger than the bolt size(s) for those locations.

Once you have drilled the holes into the vehicle, the raw metal edges should be sealed using a self-etching primer to resist corrosion and potential fastener point failure.

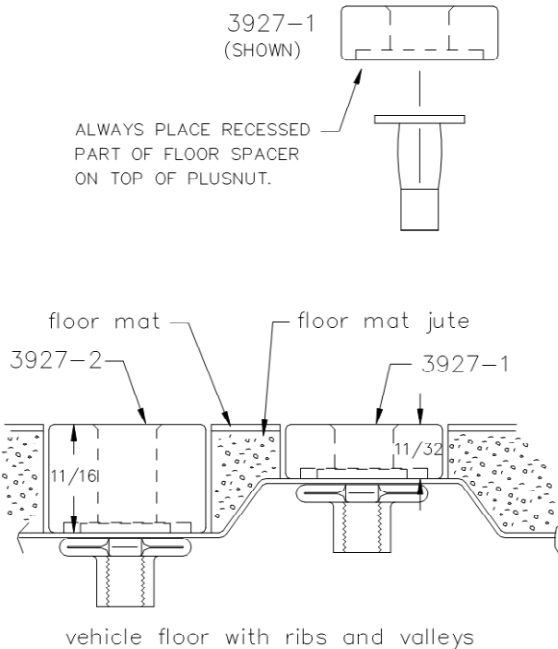

A PLUSNUT (RIVNUT) SETTING TOOL IS REQUIRED FOR PLUSNUT (RIVNUT) INSTALLATION . PLUS NUT SETTING TOOL CAN BE ORDERED THROUGH ADRIAN STEEL, OR USE AN AIR POWERED PLUSNUT SETTING GUN.

1/4-20UNC Plusnut (FAS0052) Use 3/8" dia. drill w/stop  
 FAS0080 SCREW, HXHD, 1/4-20UNCx2.00", G8  
 FAS0067 WASHER, FLAT, 1/4"ID  
 22200-0 PLUSNUT TOOL

5/16-18UNC Plusnut (FAS0091) Use 1/2" dia. drill w/stop  
 FAS0095 SCREW, HXHD, 5/16-18UNCx2.00", G8  
 FAS0086 WASHER, FLAT, 5/16"ID  
 22200-0 PLUSNUT TOOL

Place barrel of the plusnut body in sheet metal thru hole until flange is flush with sheet metal.  
 Using a 9/16" combination wrench of plusnut tool body and a second hand wrench, ratchet, or air tool, rotate the hex bolt head CW to draw plus nut flanges up (set the plusnut).

**Installation and/or Assembly Fasteners**  
**BAG56661**

ITEM NO.	PART NUMBER	DESCRIPTION	BAG5666 1/QTY.
1	BAG0406-A	4" x 6" 3MIL AUTOBAG	1
2	FAS0830	Screw, Hex Hd, 5/16-18 X 1.25 SS	8
3	FAS0552	Washer, Flat, 5/16, SST	16
4	FAS0248	Nut, Nylon Insert Lock, 5/16-18 SST	8

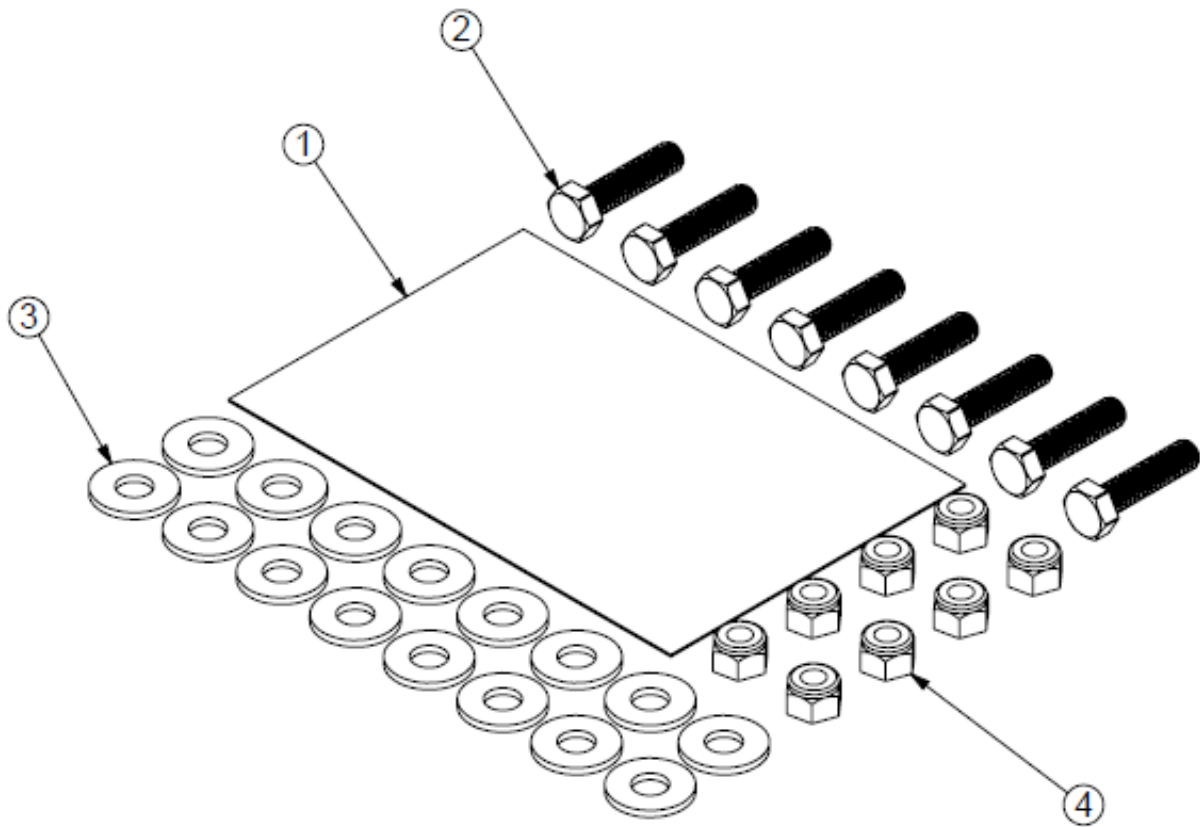



**Installation and/or Assembly Fasteners  
BAG52539**

ITEM NO.	PART NUMBER	DESCRIPTION	QTY.
1	BAG0406-A	4" x 6" 3MIL AUTOBAG	1
2	FAS0552	Washer, Flat, 5/16, SST	16
3	FAS0759	5/16-18 U-NUT	16
4	FAS0283	Screw, Hex Hd, 5/16-18 x.875 SST	16
5	FAS0588	Washer, Lock, Split, 5/16, SS	16

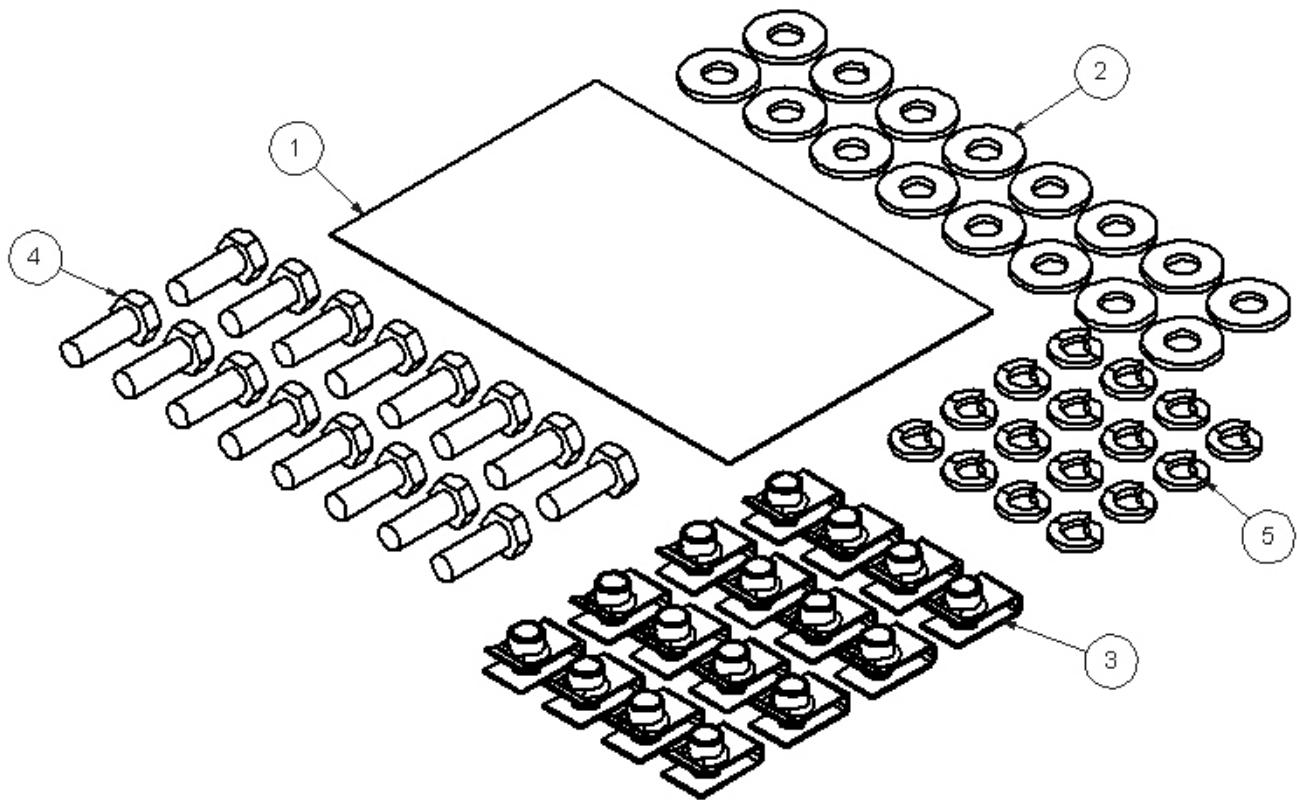

**Step 01** ALIGN ROOF RAILS AND CLIPS WITH THE VAN'S MOUNTING HOLES AND FASTEN DOWN.

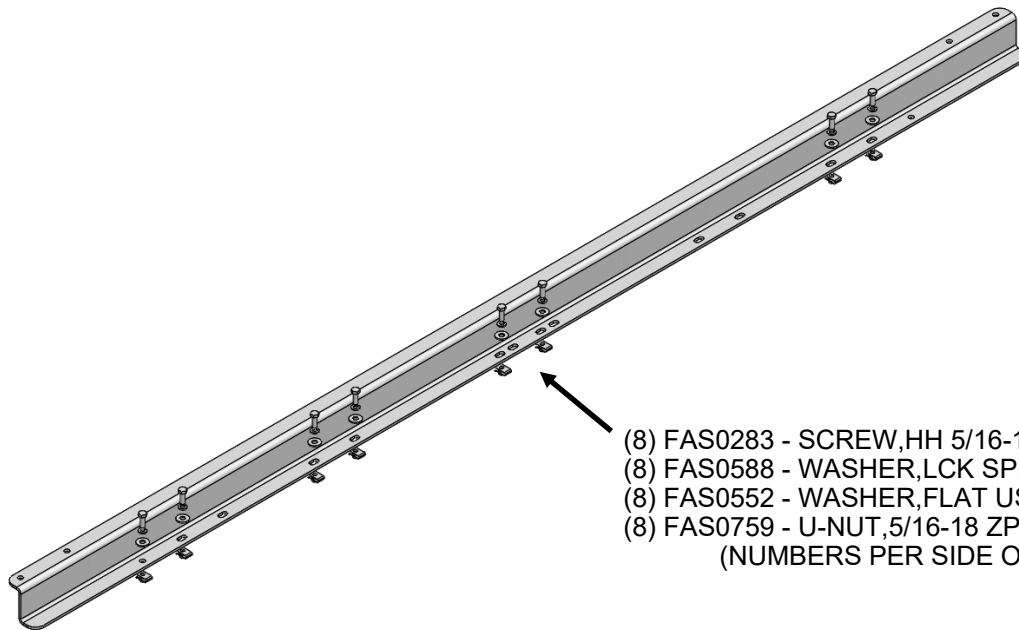

**NISSAN NV CARGO HIGH ROOF**  
Fastens to the van through holes 1, 2, 4, 5, 6, 8, 12 and 13.

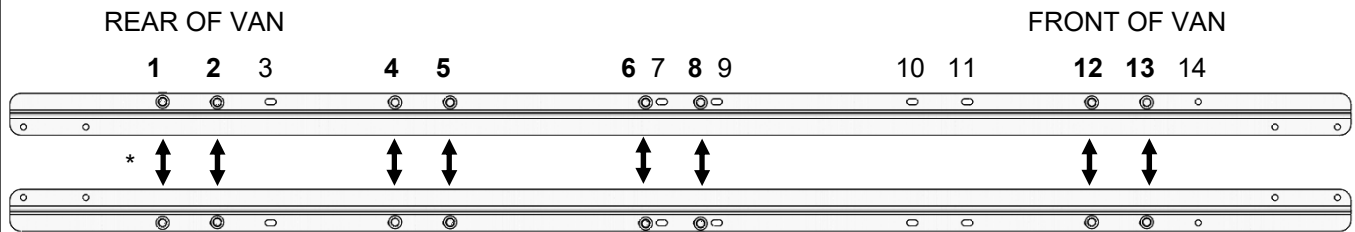

\* ARROWS INDICATE MOUNTING HOLES USED TO ATTACH TO THE ROOF OF THE VAN.

FAS0283—5/16 X 7/8" LG HHCS (16)  
FAS0588—LW (16)  
FAS0552—FW (16)

MOUNTING RAIL ON THE VEHICLE

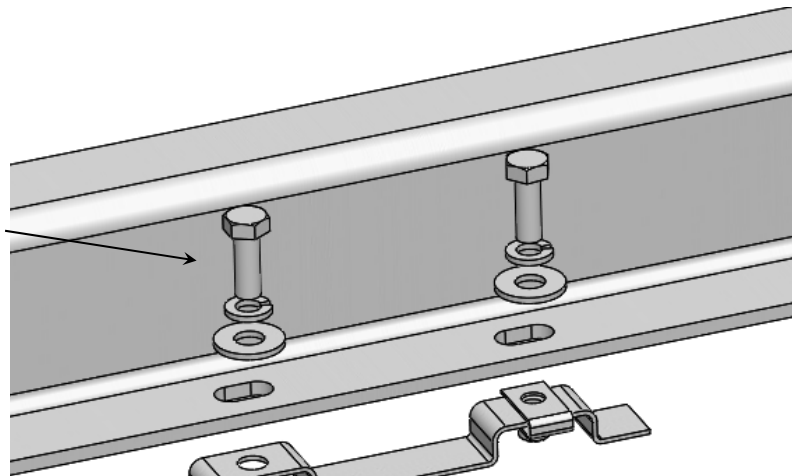

FAS0759—CLIP (16)

**Step 03** ATTACH THE FRONT AND REAR CROSSBOWS TO THE ROOF RAILS. THIS NEEDS TO BE DONE AS A STEP OF THE DDLR HIGH ROOF UNIT ASSEMBLY. NOTE: IF YOUR DRIVELINE IS NOT INSTALLED BETWEEN THE CROSSBOWS PRIOR TO FASTENING YOU WILL HAVE TO REMOVE THEM FROM THE ROOF RAILS AND DO SO. TORQUE FASTENERS TO 12-15 FT.LBS.

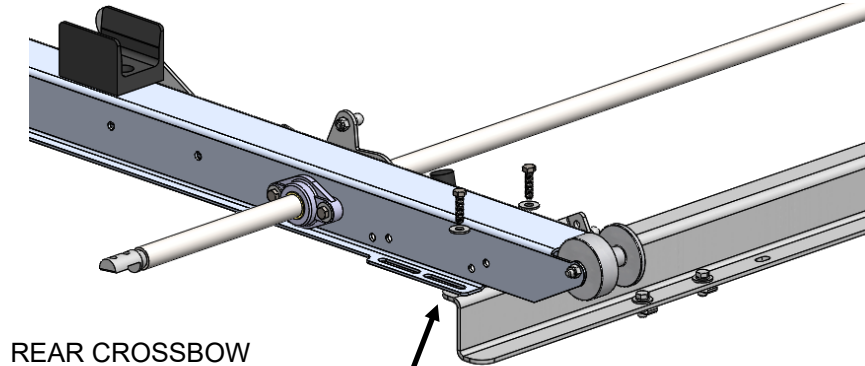

FAS0830 5/16 HH SCREW (8)  
FAS0552 5/16 WASHER (16)  
FAS0248 5/16 LOCKNUT (8)

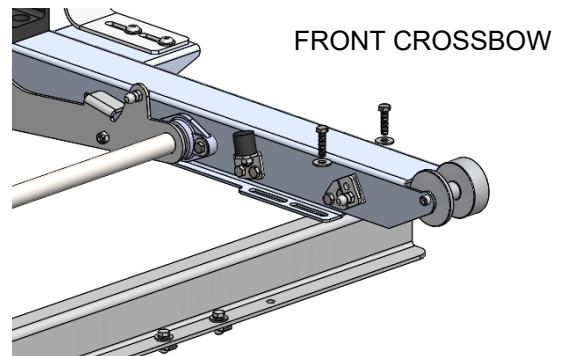

## **ATTENTION!** **LADDER RACK PURCHASER**

IT IS ADVISED THAT ALL FASTENERS THAT ASSEMBLE AND INSTALL YOUR LADDER RACK ARE CHECKED FOR TIGHTNESS AT 2 WEEKS OF OPERATION AND THEN RECHECKED AGAIN AT 6 WEEKS OF OPERATION.

ASSEMBLY FASTENERS COULD LOOSEN DURING USE DUE TO VIBRATION THROUGH YOUR VEHICLE WHILE ON THE ROAD OR IN AND OUT OF CONSTRUCTION SITES.

THIS IS A PREVENTATIVE MAINTENANCE STEP TO INSURE YOUR LADDER RACK GIVES YOU A LONG SERVICE LIFE.

\*\*INSTALLER: PLEASE PRESENT THIS STATEMENT TO THE END USER WHEN DELIVERING THE INSTALLED PRODUCT!

YOUR ROOF RAIL KIT IS NOW COMPLETELY INSTALLED. THIS IS WHAT YOUR LADDER RACK SHOULD LOOK LIKE AT THIS TIME. REFER BACK TO THE DDLR INSTALL INSTRUCTOINS TO COMPLETE YOUR LADDER RACK ASSEMBLY.



THE FOLLOWING VIEWS ARE OF COMPLETED 61 AND 63 LADDER RACK UNITS USING THIS ROOF RAIL KIT.

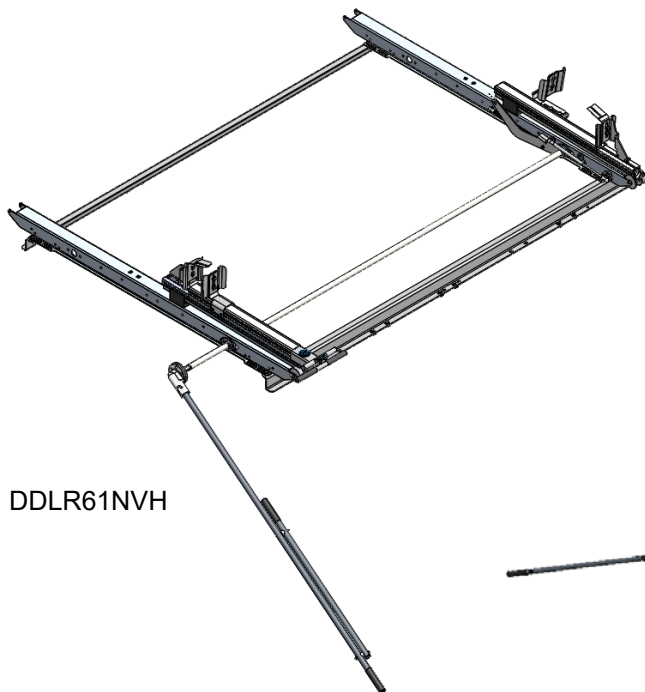

DDLR61NVH

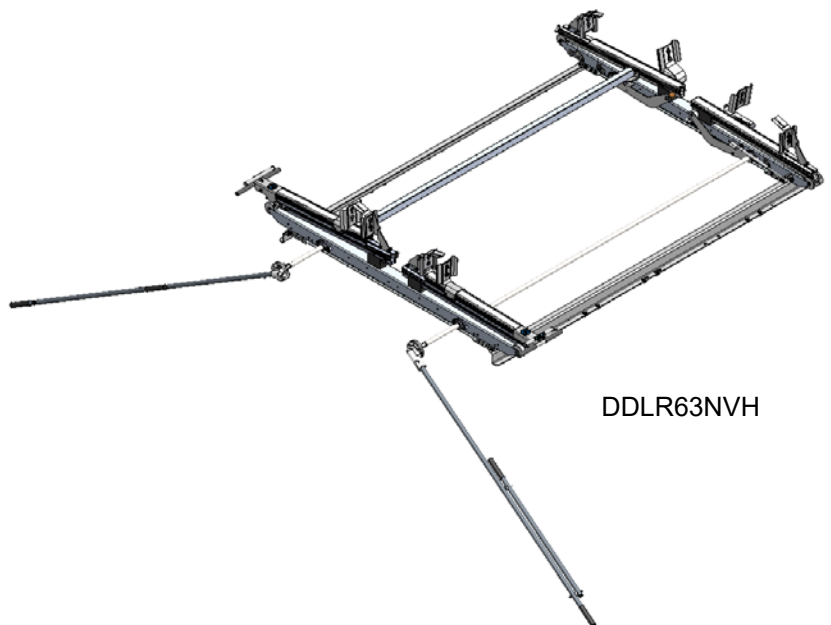

DDLR63NVH