

Introduction / Comments:

THIS DROP DOWN UNIT IS CURB SIDE, STREET SIDE SPECIFIC. THE DROP DOWN IS FOR LOW ROOF VEHICLES, THESE INSTRUCTIONS WILL BE SHOWING THE FORD TRANSIT FOR THE VEHICLE REPRESENTATION. THIS DROP DOWN LADDER RACK IS DESIGNED TO ADAPT TO AN ADRIAN STEEL CROSS BOW KIT FOR VARIOUS STANDARD ROOF VEHICLES.

Note:

It is advised that all fasteners used in this assembly and installation of this Rack should be checked for tightness at the following intervals: @ 2-weeks and again @ 6-weeks of operation. This preventive maintenance step must be completed to ensure your package gives you long service life.

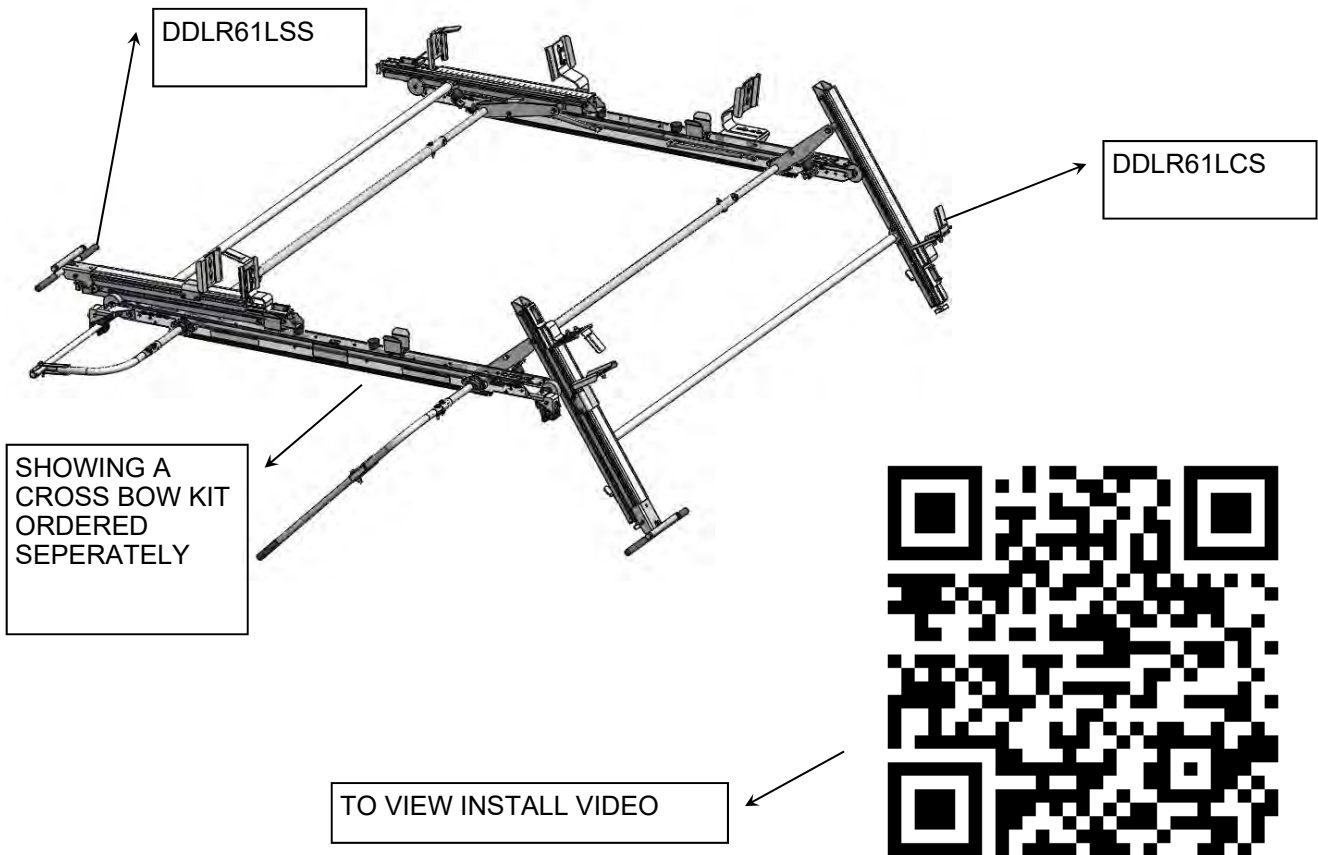

**DDL61FTL / DDL63FTL
DROP DOWN LADDER RACK, STREET, CURB
VARIOUS LOW ROOF VANS**

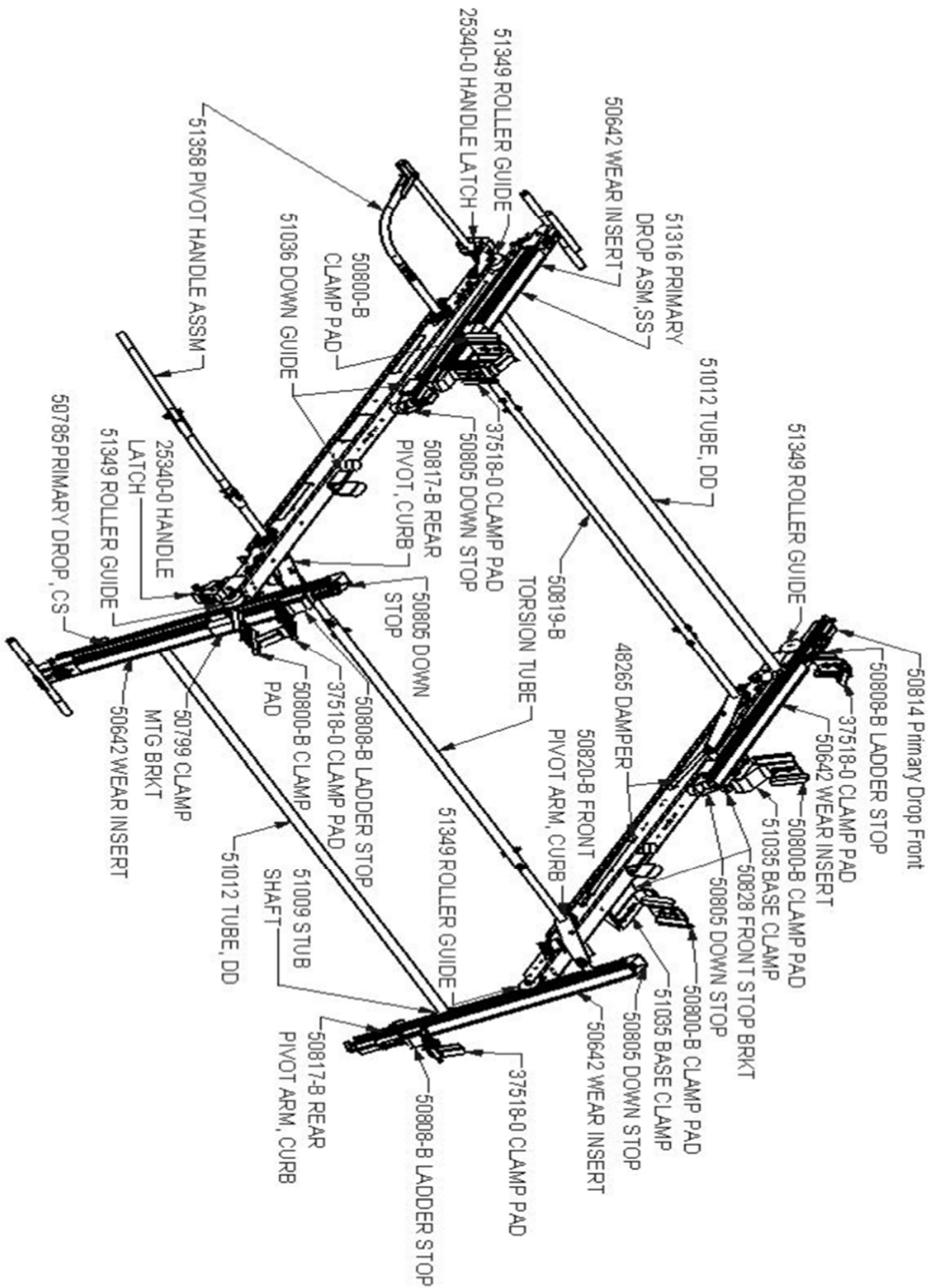

- PRECAUTIONS -





 **CAUTION** 
**THE USE OF AIR IMPACT TOOLS CAN
OVER-TORQUE FASTENERS AND
CAUSE FASTENER FAILURE!**



 **CAUTION** 
**ALL INSTALLATION HOLES SHOULD BE SEALED
WITH SILICON OR BUTYL SEALANT TO PREVENT
EXHAUST FUMES FROM ENTERING THE VEHICLE!**



 **DANGER** 
**INSPECT FOR FUEL TANK, FUEL LINES, BRAKE LINES, HIGH
VOLTAGE BATTERIES AND ELECTRICAL LINES PRIOR TO
DRILLING TO AVOID DAMAGING CRITICAL VEHICLE SYSTEMS
OR INJURY TO INSTALLER DURING INSTALLATION PROCESS!**



 **CAUTION** 
**TO AVOID DAMAGING THE VEHICLE ALWAYS
USE DRILL STOPS WHEN DRILLING ANY IN-
STALLATION HOLES!**



- IMPORTANT WARRANTY REQUIREMENTS -

1. SUBSTITUTING ADRIAN STEEL SPECIFIED FASTENERS FOR ASSEMBLY AND/OR INSTALLATION WILL VOID YOUR PRODUCT WARRANTY.
2. ALL HOLES DRILLED INTO VEHICLE SHOULD HAVE THE RAW METAL EDGES SEALED WITH A SELF-ETCHING PRIMER TO RESIST CORROSION AND POTENTIAL FASTENER POINT FAILURE.
3. ALL FASTENERS USED IN THE INSTALLATION OF THIS PRODUCT SHOULD BE TIGHTENED TO THE TORQUE(S) SPECIFIED IN THESE INSTRUCTIONS.
4. THESE INSTRUCTIONS SHOULD BE KEPT WITH THE VEHICLE.

THE BASIC TOOLS NEEDED FOR MOST INSTALLATIONS



DRILL



DRILL BIT WITH
STOP



RATCHET, SOCKETS
AND/OR WRENCHES



SCREWDRIVERS



MEASURING TAPE

ADDITIONAL TOOLS MAY BE NEEDED FOR THIS INSTALLATION AND THEY WILL BE IDENTIFIED IN THE STEPS THAT FOLLOW.

BAG51043 - DROP DOWN ASSEMBLY BAG

ITEM NO.	PART NUMBER	DESCRIPTION	QTY.
1	BAG0507-A	5" x 7" 3MIL AUTOBAG	1
2	FAS0248	Nut, Nylon Insert Lock, 5/16-18 SST	31
3	34927-0	Ball Stud, Damper	4
4	34924-0	Neoprene Bumper	4
5	FAS0552	Washer, Flat, 5/16, SST	23
6	FAS0830	Screw, Hex Hd, 5/16-18 X 1.25 SS	7
7	FAS0799	Screw, Hex Hd, 5/16-18x0.75 SS	8
8	FAS0179	Screw, Hex Hd, 5/16-18x2.00 STAINLESS STEEL	6
9	FAS0811	SCREW,CAP, 5/16-18X3.50 SS	2
10	26618-0	Silicone Sealant	1
11	34928-0	Clip, Suspa P/N P68-00019	4
12	05586-0	Butyl Tape, T224 -1/2"X 1' Roll	1

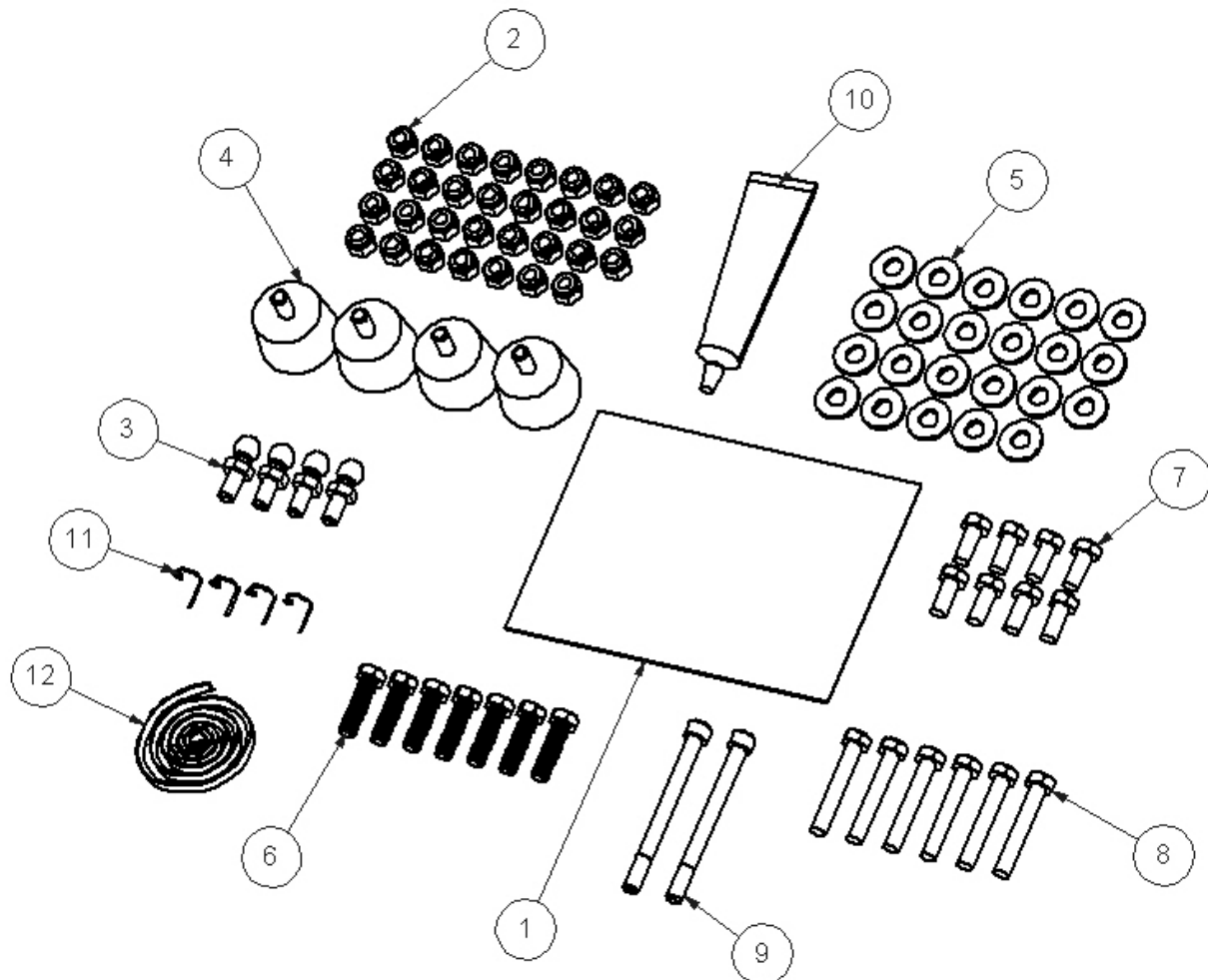

BAG51041—FINAL ASSEMBLY FASTENER BAG

ITEM NO.	PART NUMBER	DESCRIPTION	QTY.
1	BAG0507-A	5" x 7" 3MIL AUTOBAG	1
2	FAS0246	Washer, Flat, 3/8, HRD, ZN	6
3	FAS0799	Screw, Hex Hd, 5/16-18x0.75 SS	4
4	FAS0110	Nut,Hex Nylk 3/8-16 SS W	4
5	FAS0572	Screw, Button Hd Hex Soc, 3/8-16x1.00 NI-ZN	2
6	FAS0588	Washer, Lock, Split, 5/16, SS	4
7	FAS0286	SCREW, HHCS, 3/8-16x4, SS	2
8	FAS0287	COTTER PIN, 1/16DIA X 1"LG, SS	2

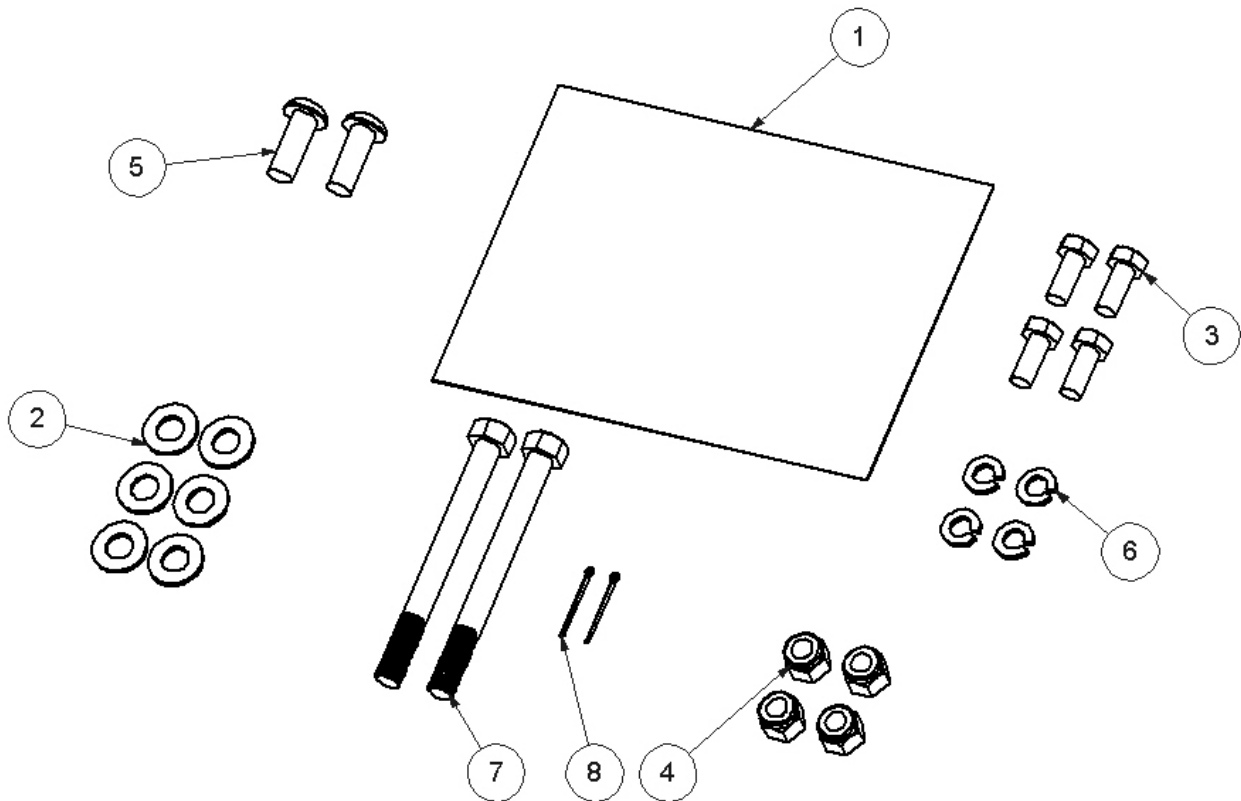

STEP #1 : ASSEMBLE CURB SIDE REAR CROSS BOW

REAR OF THE VAN

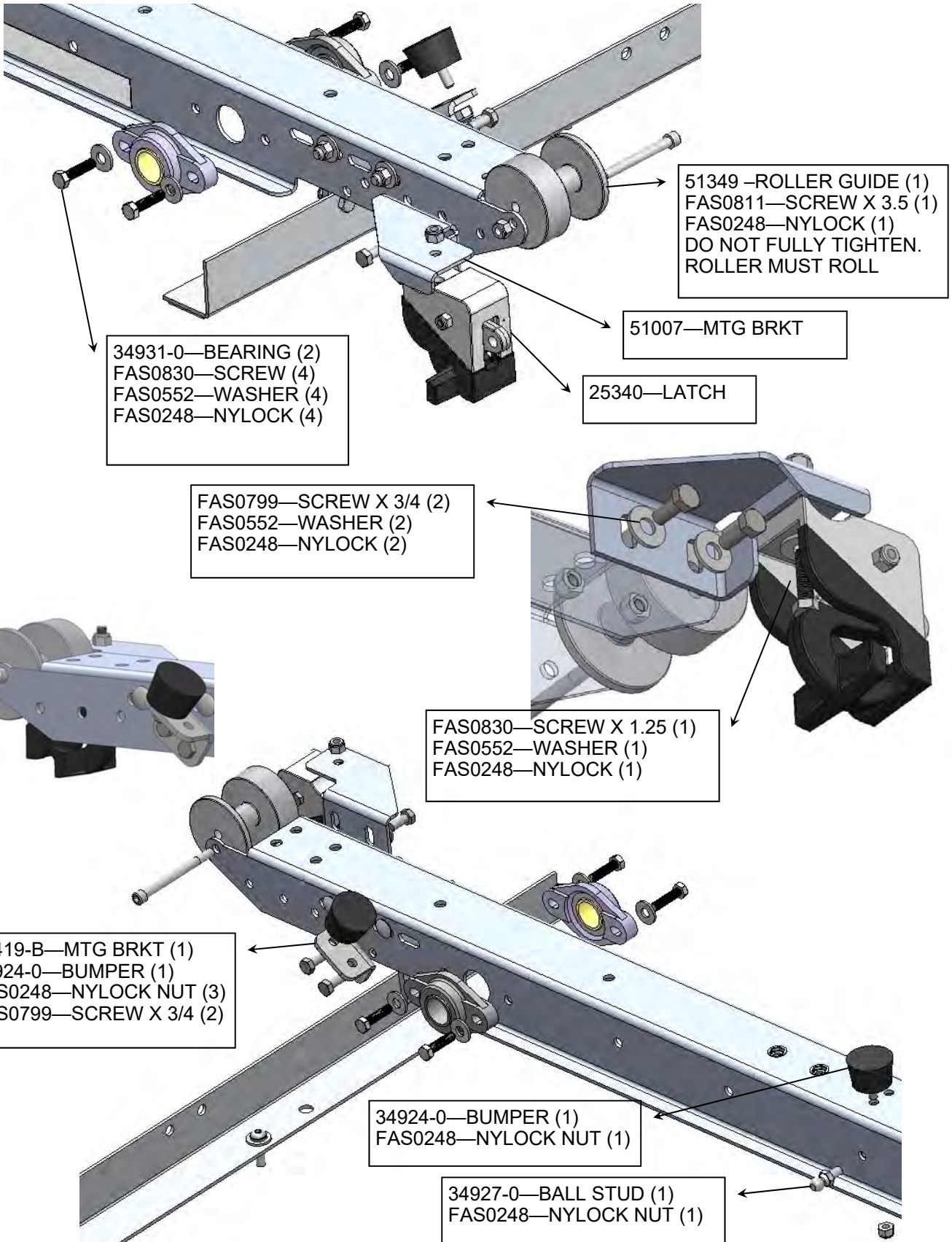



STEP #2 : ASSEMBLE CURB SIDE FRONT CROSS BOW. DO NOT ATTACH TO THE RAIL YET.

- 50828—MTG PLATE (1)
- FAS0799 -SCREW X 3/4 (2)
- FAS0552—WASHER (2)
- FAS0248—NYLOCK (2)

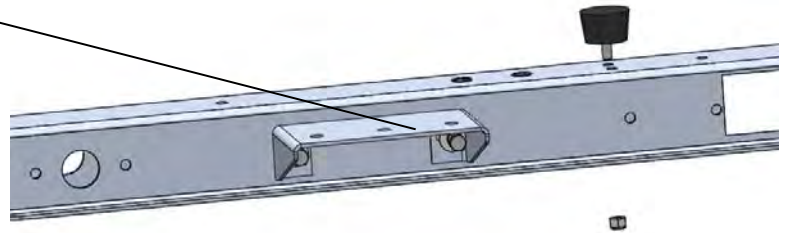

- 34924-0—BUMPER (1)
- FAS0248—NYLOCK NUT (1)

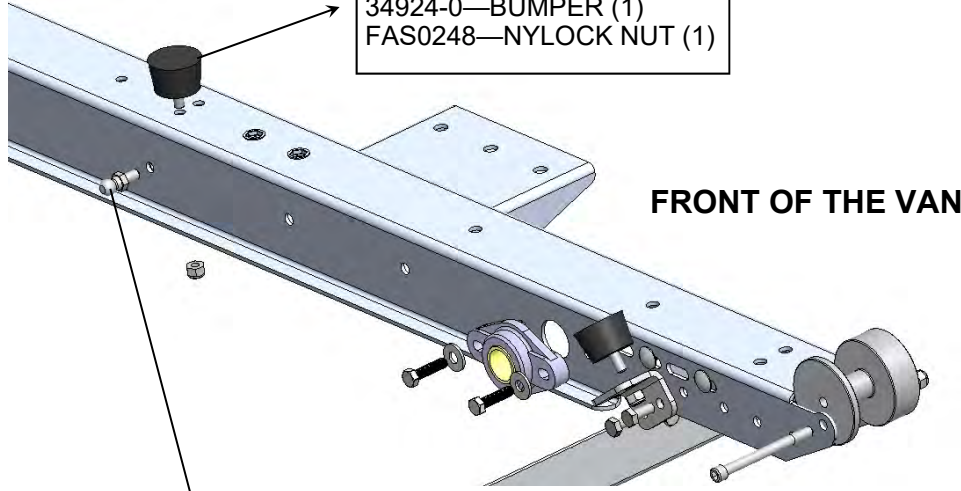

- 34927-0—BALL STUD (1)
- FAS0248—NYLOCK NUT (1)

- 51349 –ROLLER GUIDE (1)
- FAS0811—SCREW X 3.5 (1)
- FAS0248—NYLOCK (1)
- DO NOT FULLY TIGHTEN. ROLLER MUST ROLL

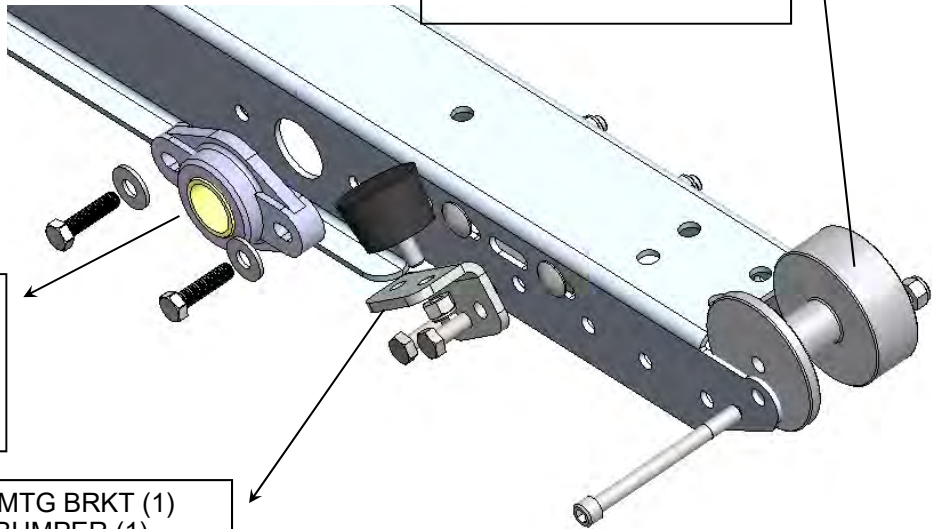

- 34931-0—BEARING (1)
- FAS0830—SCREW (2)
- FAS0552—WASHER (2)
- FAS0248—NYLOCK (2)

- 40419-B—MTG BRKT (1)
- 34924-0—BUMPER (1)
- FAS0248—NYLOCK NUT (3)
- FAS0799—SCREW X 3/4 (2)

STEP #3 : ASSEMBLE CURB SIDE PIVOT DRIVE TO THE CROSS BOWS

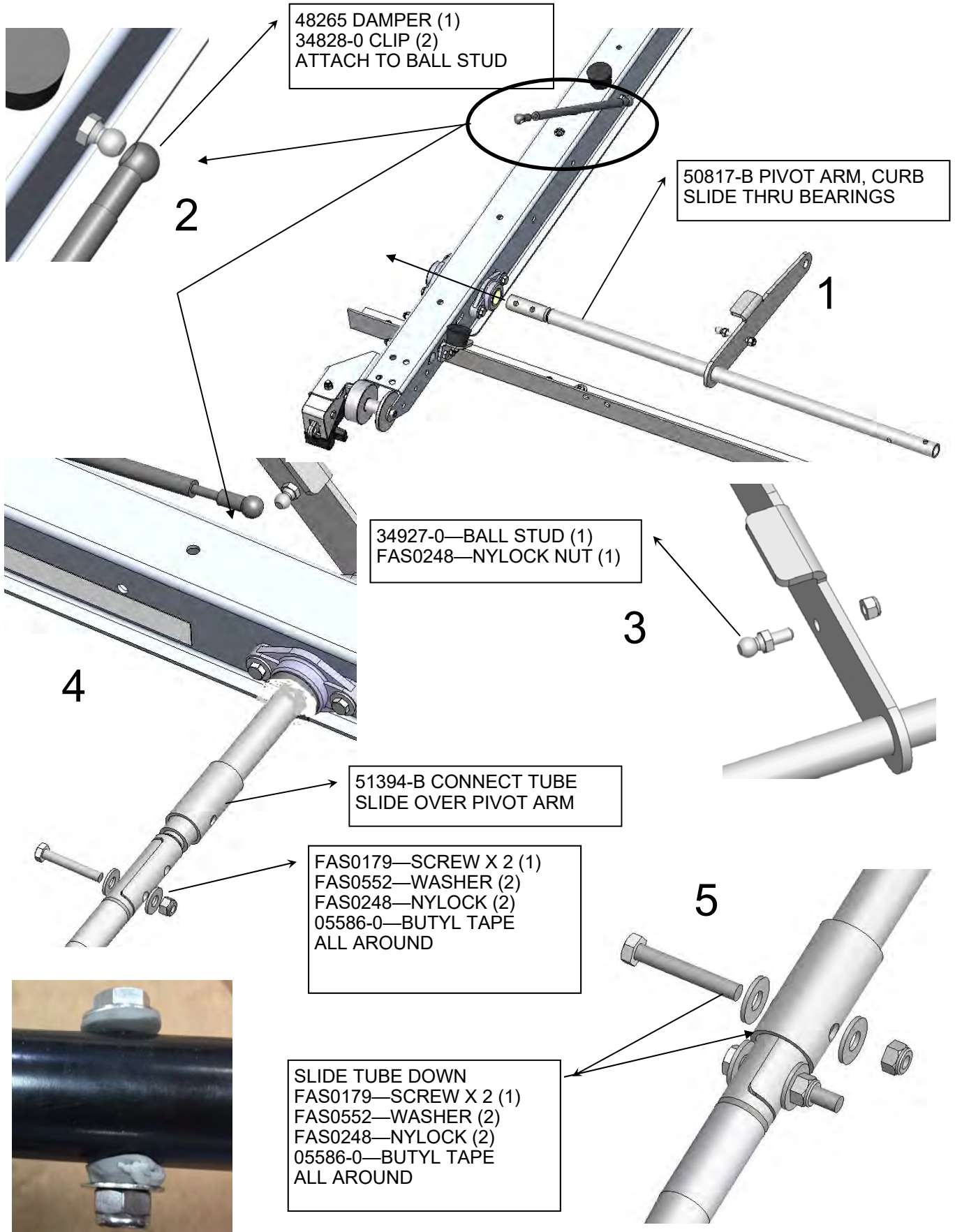

STEP #4A : ASSEMBLE CURB SIDE PIVOT DRIVE AT REAR OF VEHICLE.

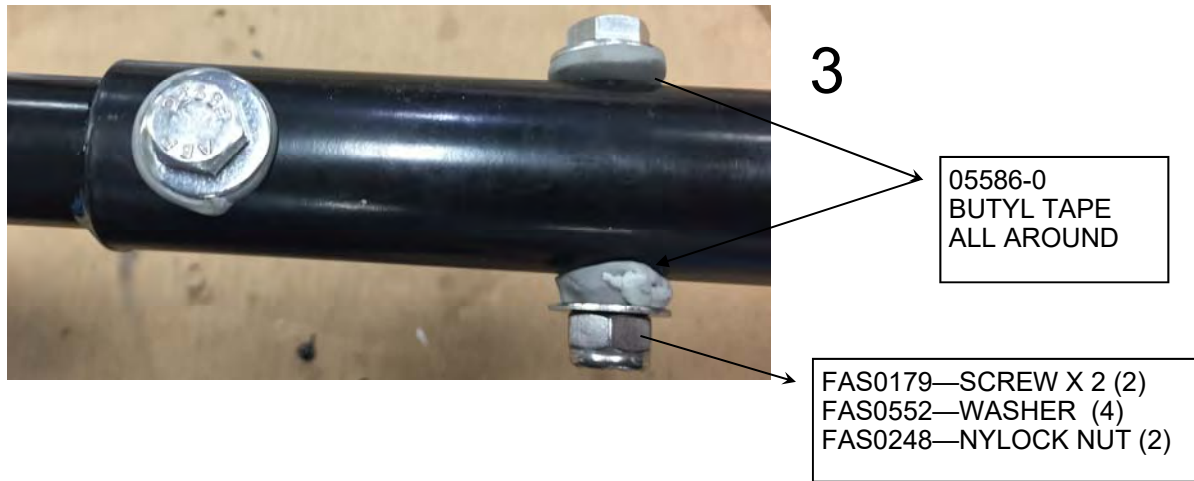
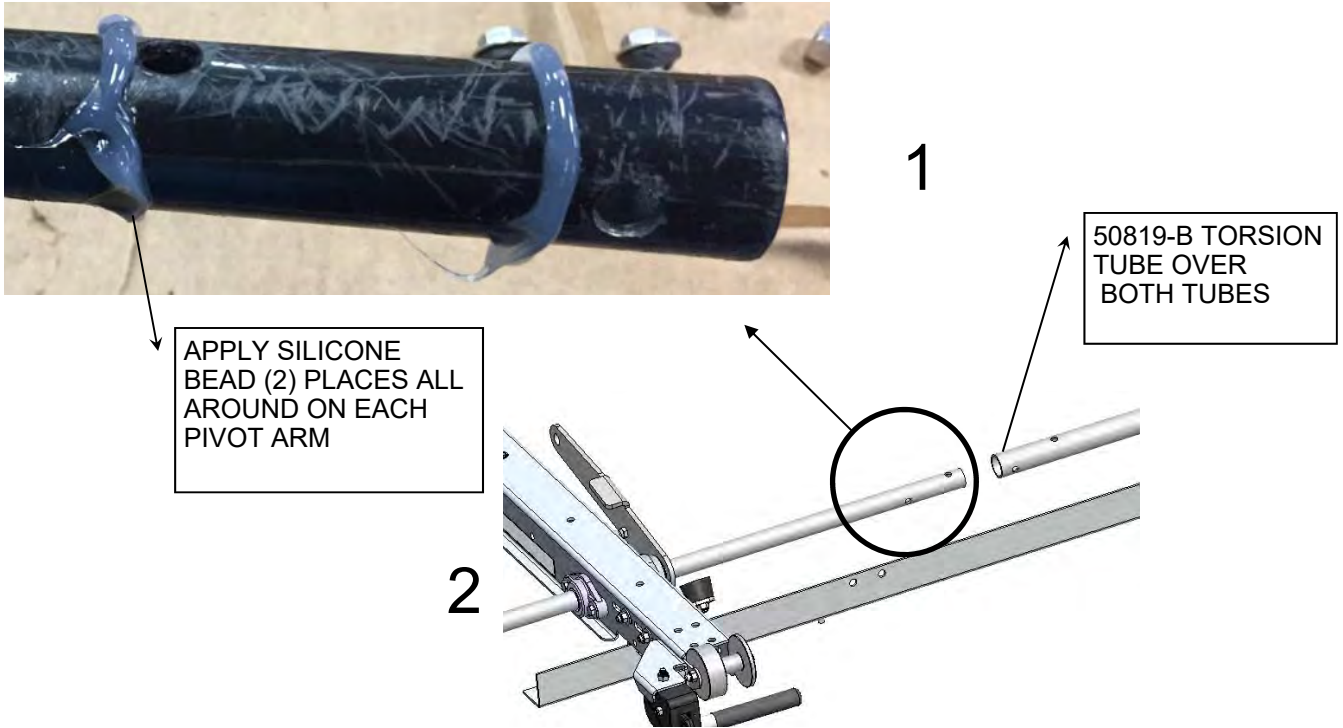

FINISHED CONNECTION

STEP #4B : ASSEMBLE CURB SIDE PIVOT DRIVE AT FRONT OF VEHICLE



APPLY SILICONE
BEAD (2) PLACES ALL
AROUND ON EACH
PIVOT ARM

5

50817-B—PIVOT ARM, CS

6

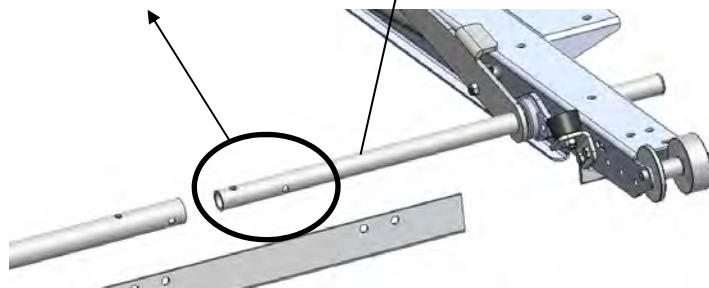

7

05586-0
BUTYL TAPE
ALL AROUND

FAS0179—SCREW X 2 (4)
FAS0552—WASHER (8)
FAS0248—NYLOCK NUT (4)

26618-0—SILOCONE
ALL AROUND

8



FINISHED CONNECTION

STEP #4C : ASSEMBLE CURB SIDE PIVOT DRIVE TO THE CROSS BOWS

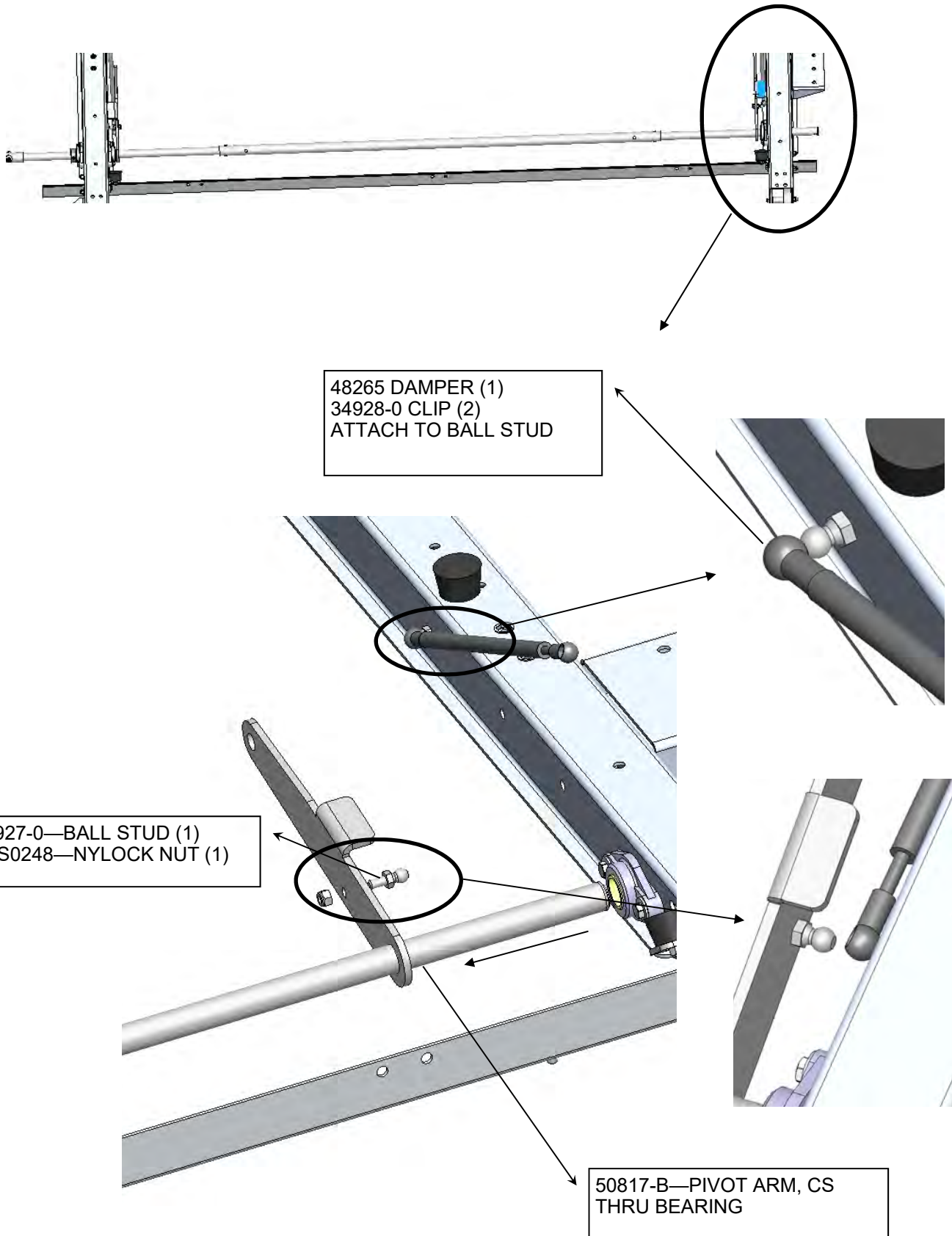



STEP #5 : THIS IS THE FINISHED CURB SIDE PIVOT DRIVE
-CONTINUE TO STEP #11 FOR A COMPLETE ASSEMBLY / INSTALL
-CONTINUE TO STEP #6 FOR THE STREET SIDE PIVOT DRIVE.

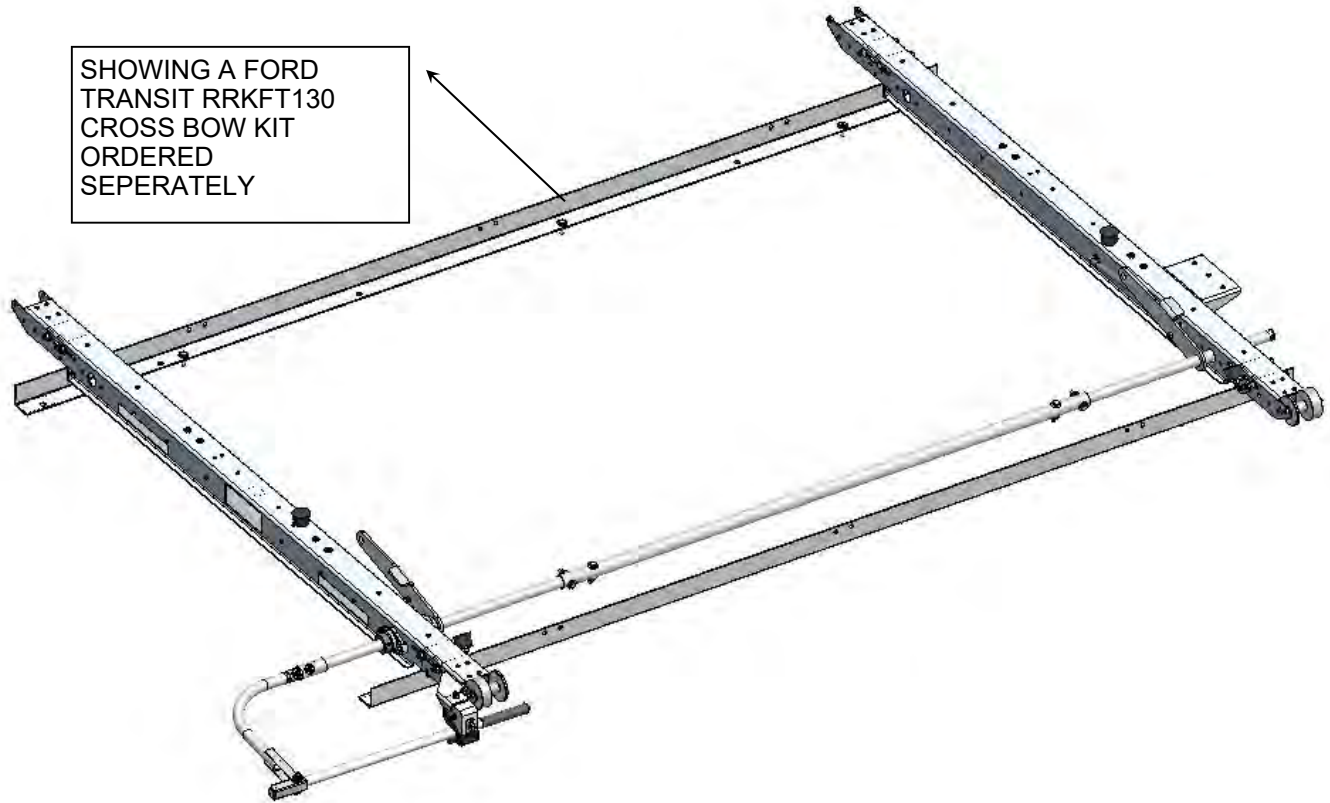

STEP #6 : THIS IS THE FINISHED CURB SIDE PIVOT DRIVE.
-CONTINUE TO STEP #7 FOR A COMPLETE ASSEMBLY / INSTALL
-CONTINUE TO STEP #9 FOR THE STREET SIDE PIVOT DRIVE



STEP #6 THRU #9: ASSEMBLE STREET SIDE REAR CROSS BOW

USE STEPS #1 THRU #4 AS YOUR GUIDE—FINAL SHIP THRU STREET SIDE ASSEMBLY SHOWN BELOW

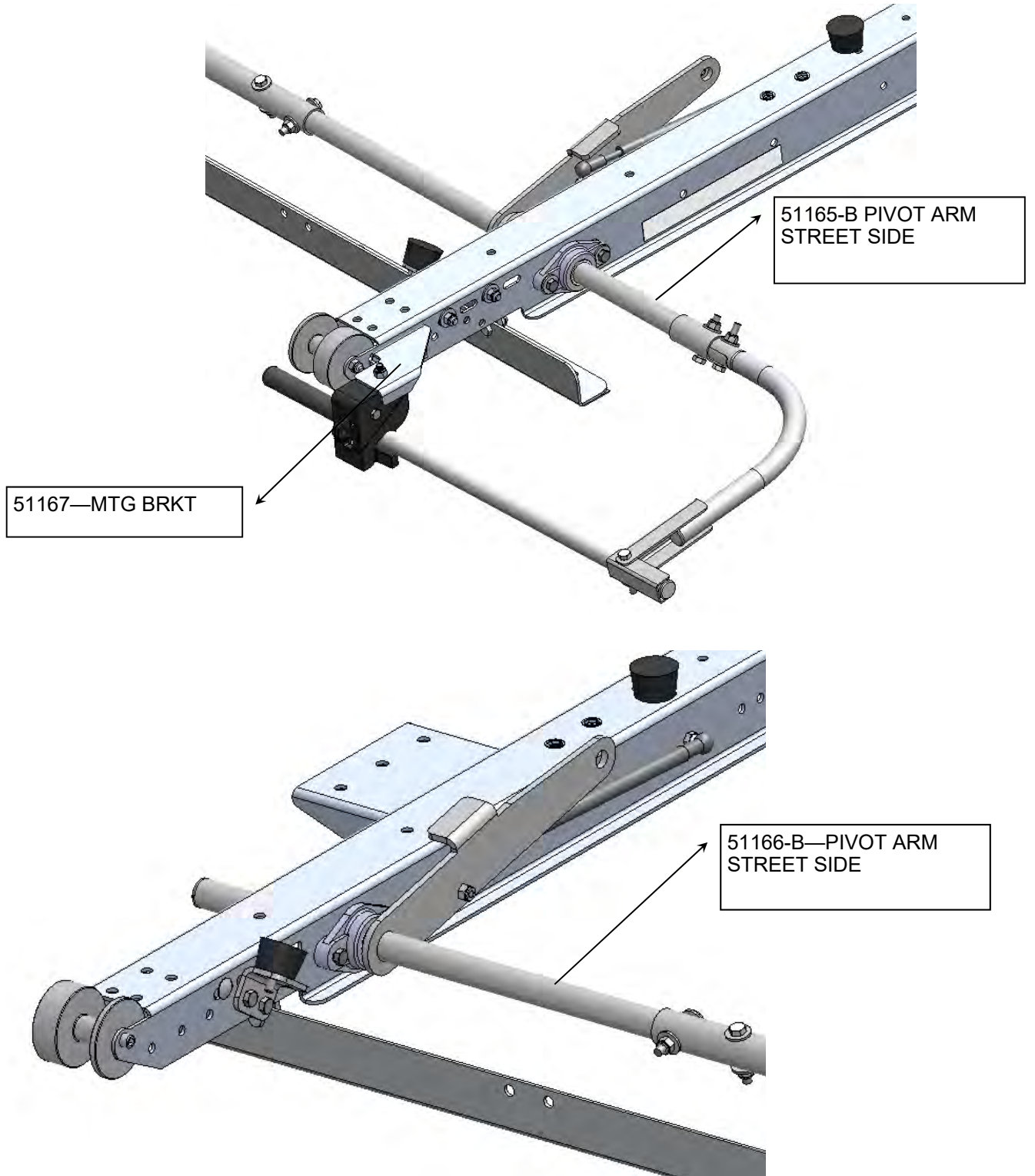

**STEP #10 : THIS IS THE FINISHED CURB AND STREET SIDE PIVOT DRIVE
-CONTINUE TO STEP #11 FOR A COMPLETE ASSEMBLY / INSTALL**



**STEP #10 : THIS IS THE FINISHED CURB AND STREET SIDE PIVOT DRIVE.
-CONTINUE TO STEP #11 FOR A COMPLETE ASSEMBLY / INSTALL**



STEP #11 - THIS IS THE FINAL ASSEMBLY, SHOWING THE CURB AND STREET SIDE DROP DOWN COMPONENTS

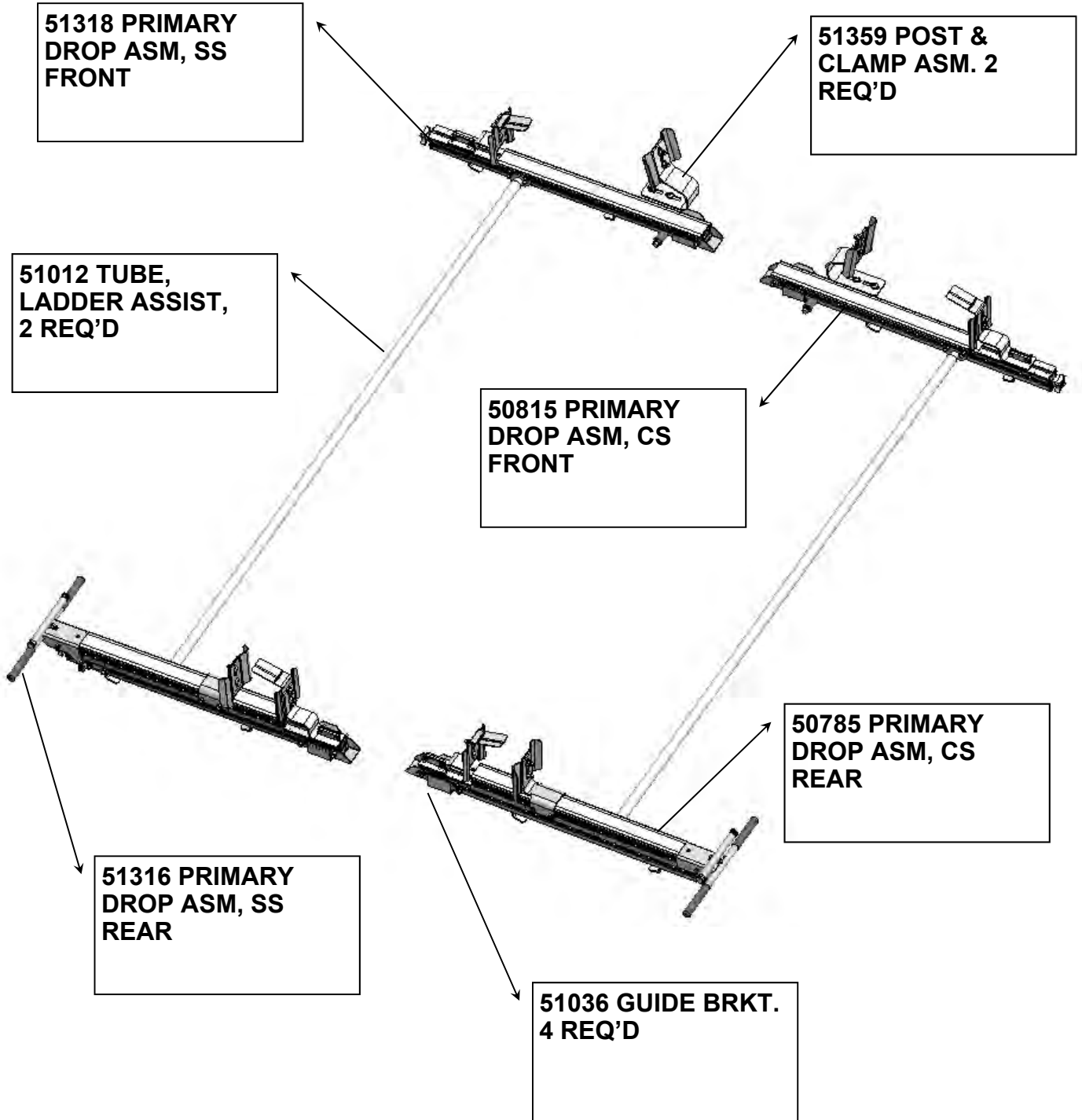

STEP 12 : ASSEMBLE BRACKETS TO THE FRONT CROSS BOW

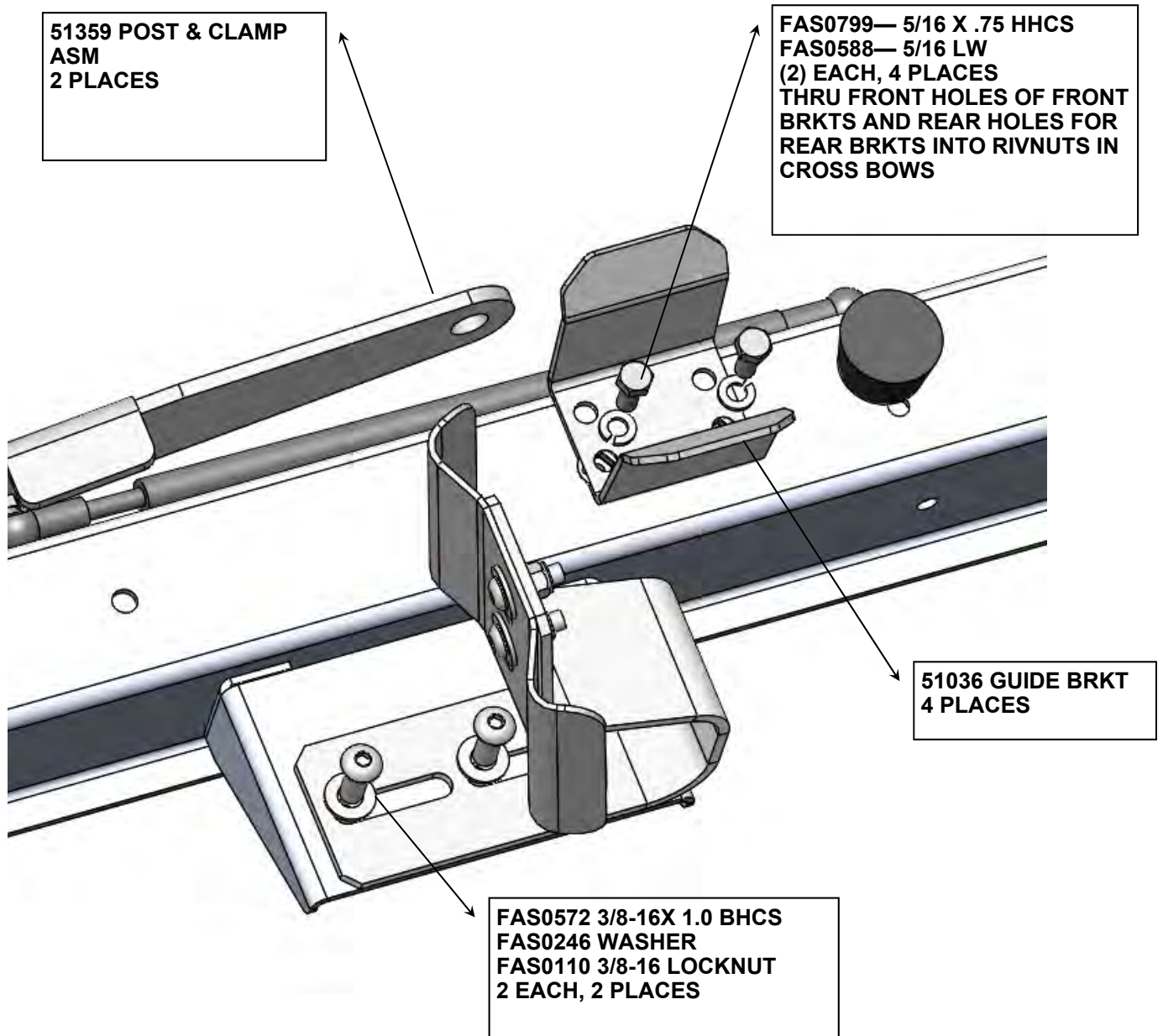

STEP 12 : COMPLETED VIEW OF THE FRONT CROSS BOW

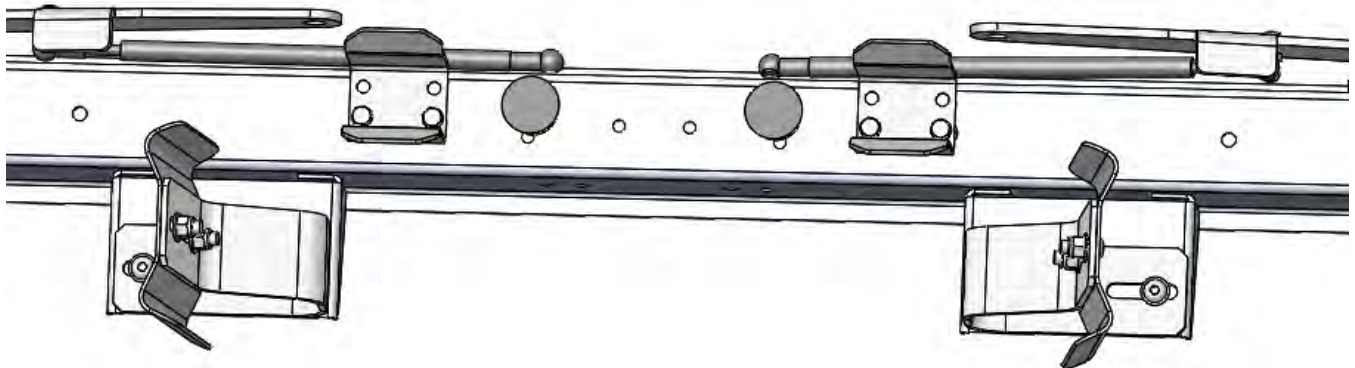

STEP 13 : ASSEMBLE REAR CURB SIDE PRIMARY DROP TO RACK

**SET 50785 PRIMARY DROP ASM, REAR CS IN PLACE ON REAR CROSS BOW.
USE GUIDE ROLLER**

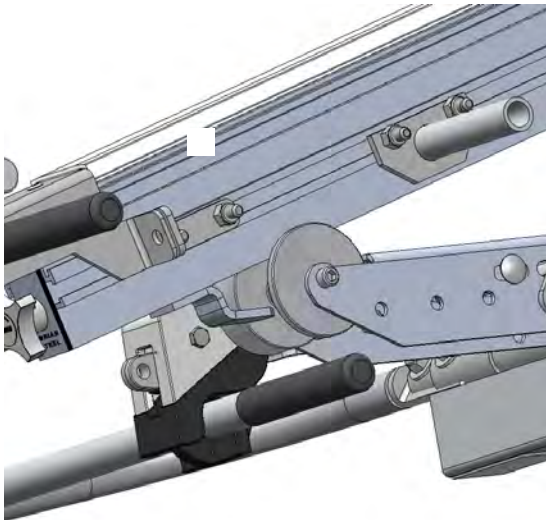

**50785 PRIMARY DROP
ASM CS REAR**

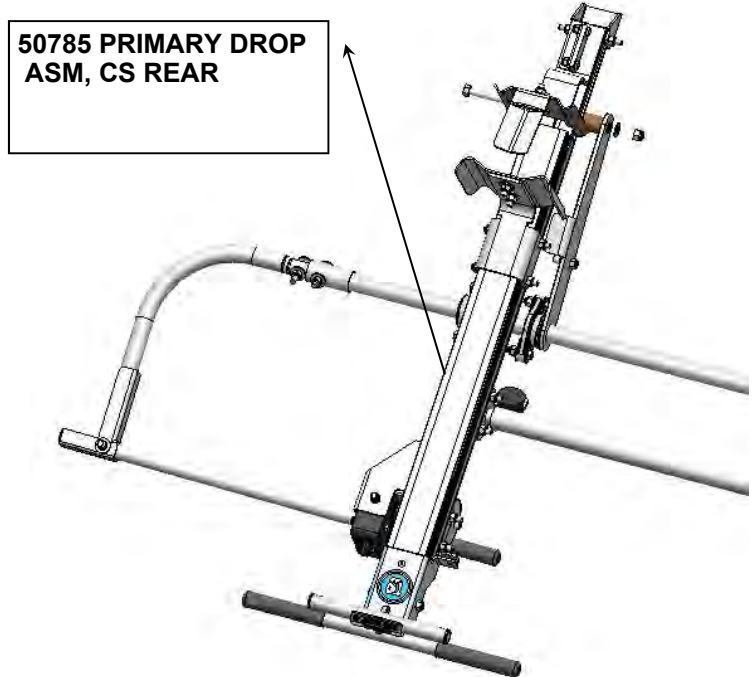

**50785 PRIMARY DROP
ASM, CS REAR**

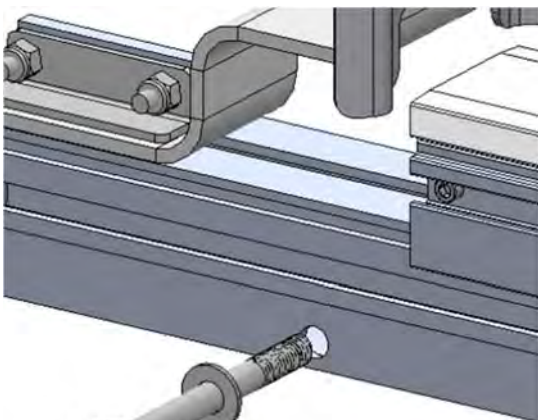

**FAS0286 3/8-16 X 4" HHCS
FAS0246 WASHER**

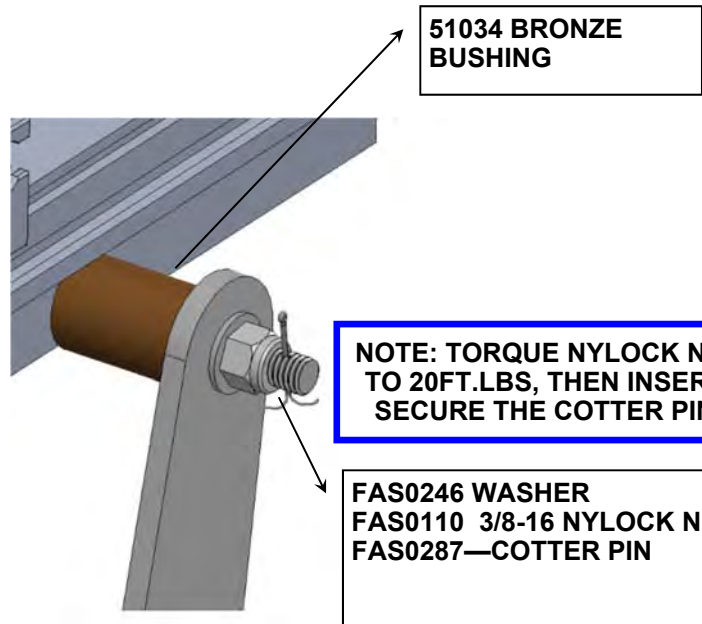

**51034 BRONZE
BUSHING**

**NOTE: TORQUE NYLOCK NUT
TO 20FT.LBS, THEN INSERT/
SECURE THE COTTER PIN.**

**FAS0246 WASHER
FAS0110 3/8-16 NYLOCK NUT
FAS0287—COTTER PIN**

**NOTE: AFTER THE COTTER
PIN IS INSERTED THROUGH
THE BOLT, SPREAD THE PIN
SO IT CAN NOT BE REMOVED.**

STEP 14 : ASSEMBLE FRONT SIDE PRIMARY DROP TO RACK

SET 50815 PRIMARY DROP ASM, FRONT CS IN PLACE ON FRONT CROSS BOW. USE GUIDE ROLLER AFTER LADDER ASSIST TUBE IS ON BOTH STUB SHAFTS

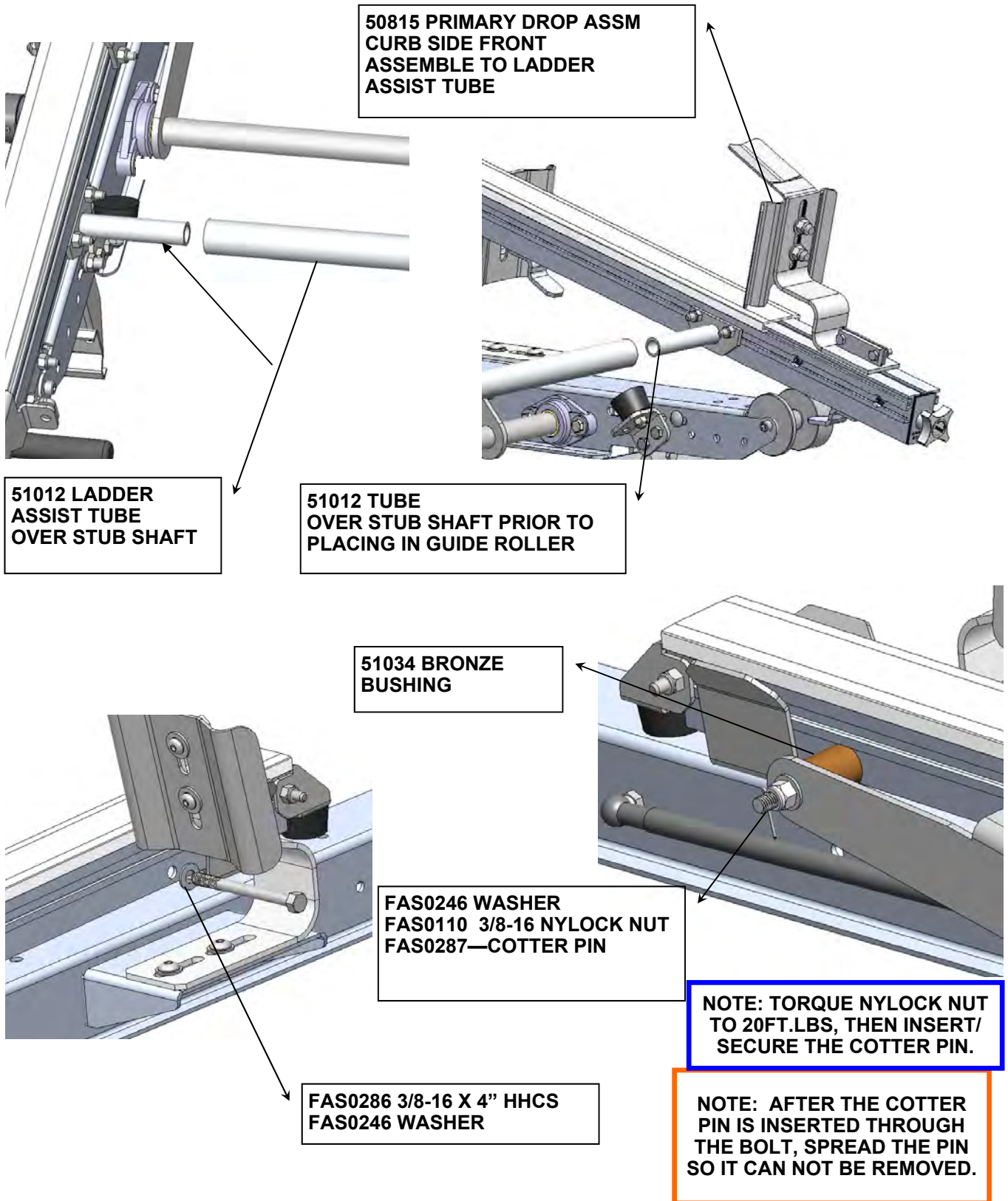



STEP #15 : FOR A DOUBLE DROP DOWN, INSTALL STREET SIDE USING STEPS #13 & 14 AS YOUR GUIDE.

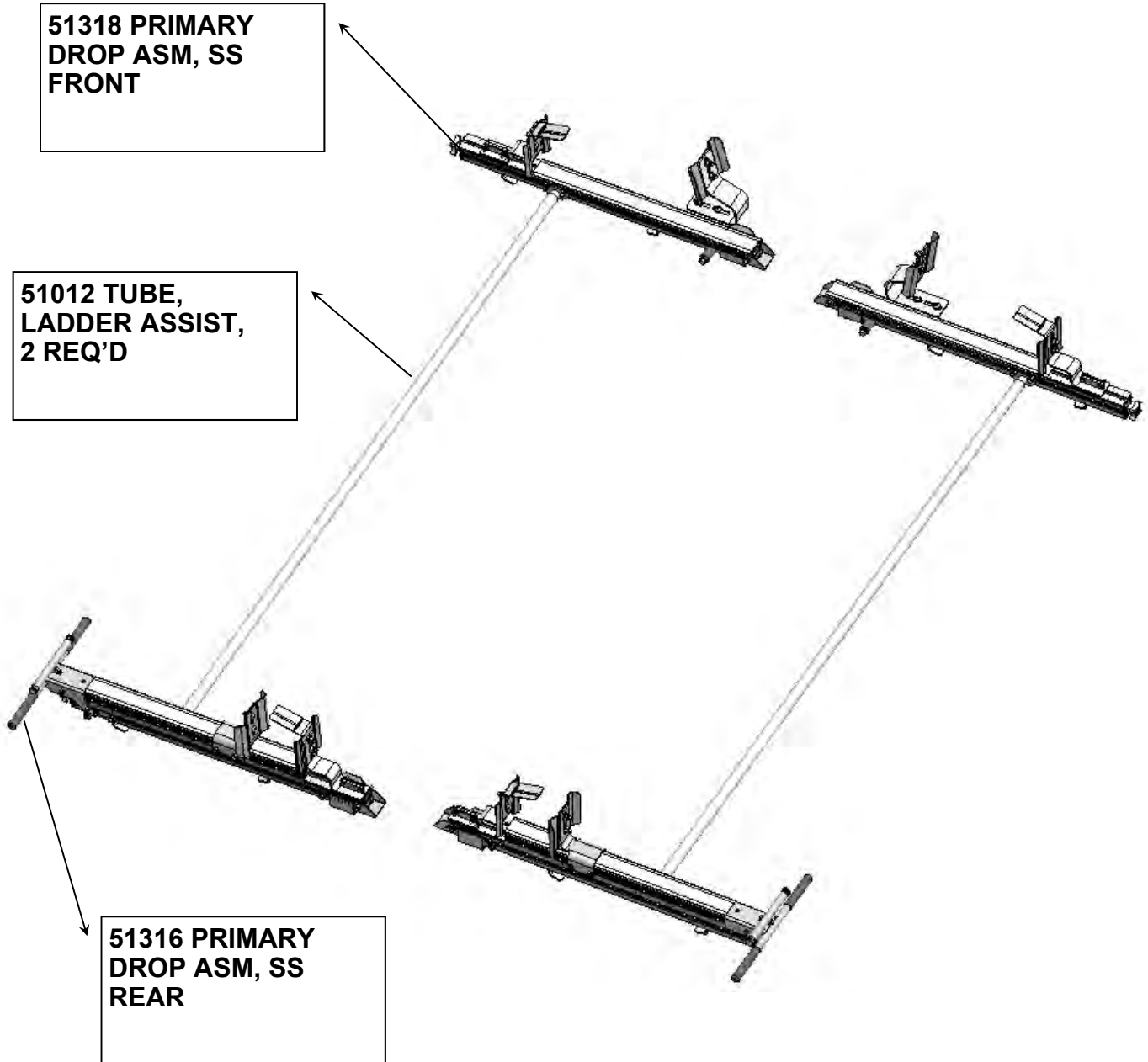

**DOUBLE CHECK ALL FASTENERS LOCATIONS TO BE SURE THAT ALL FASTENERS ARE TIGHTENED TO SPECIFICATIONS.
YOUR INSTALLATION IS NOW COMPLETE!
STOW THIS COPY IN THE VEHICLE FOR FUTURE REFERENCES!**



**STEP #16 : YOUR DOUBLE DROP DOWN INSTALLATION IS NOW COMPLETE
GO TO STEP 17 FOR A COMBO RACK**



**DOUBLE CHECK ALL FASTENERS LOCATIONS TO BE SURE THAT ALL
FASTENERS ARE TIGHTENED TO SPECIFICATIONS.
YOUR INSTALLATION IS NOW COMPLETE!
STOW THIS COPY IN THE VEHICLE FOR FUTURE REFERENCES!**



**STEP #17 : COMBO RACK, INSTALL STREET SIDE GRIP LOCK
ADD WEAR STRIPS**

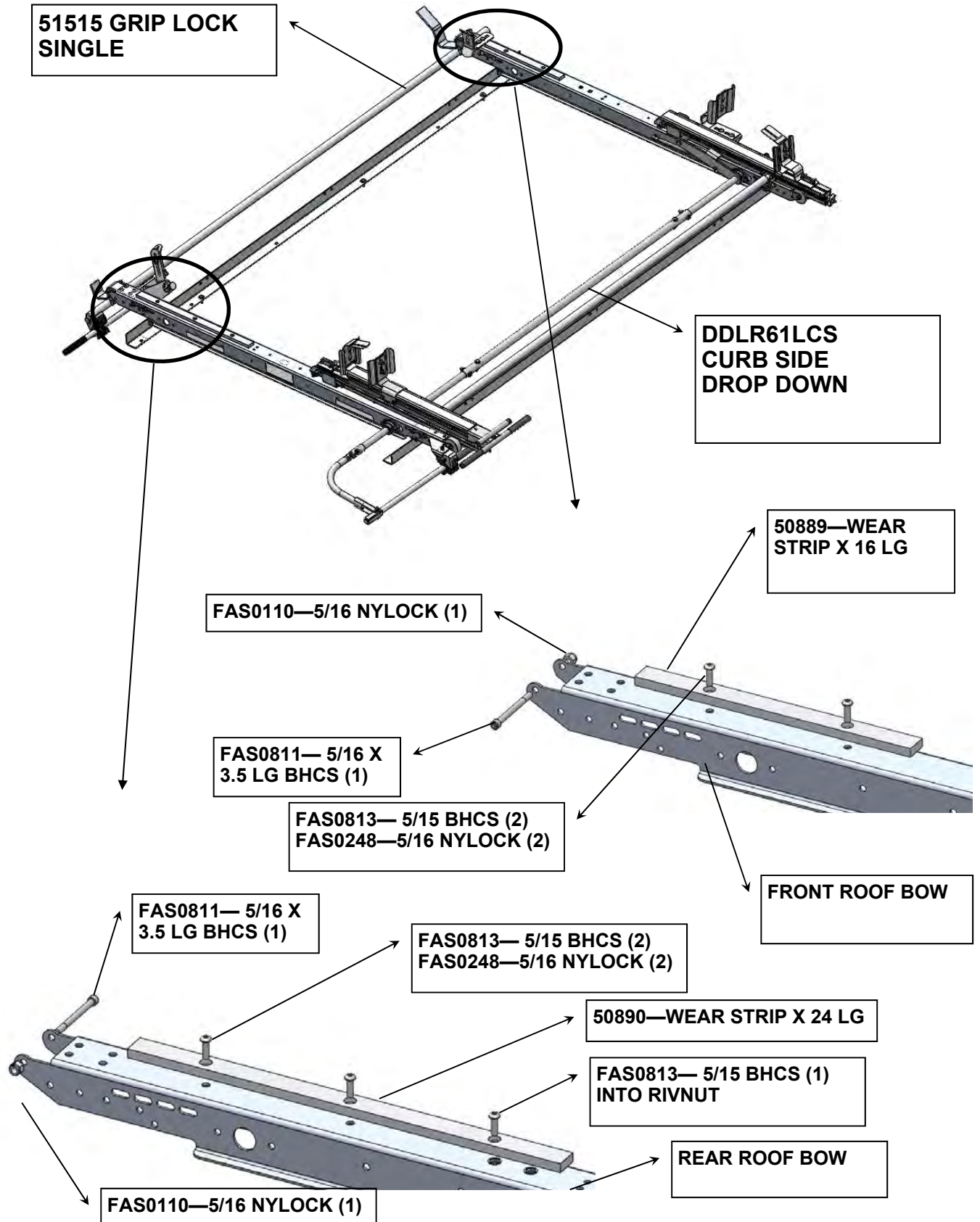

STEP #18 : COMBO RACK, INSTALL STREET SIDE GRIP LOCK

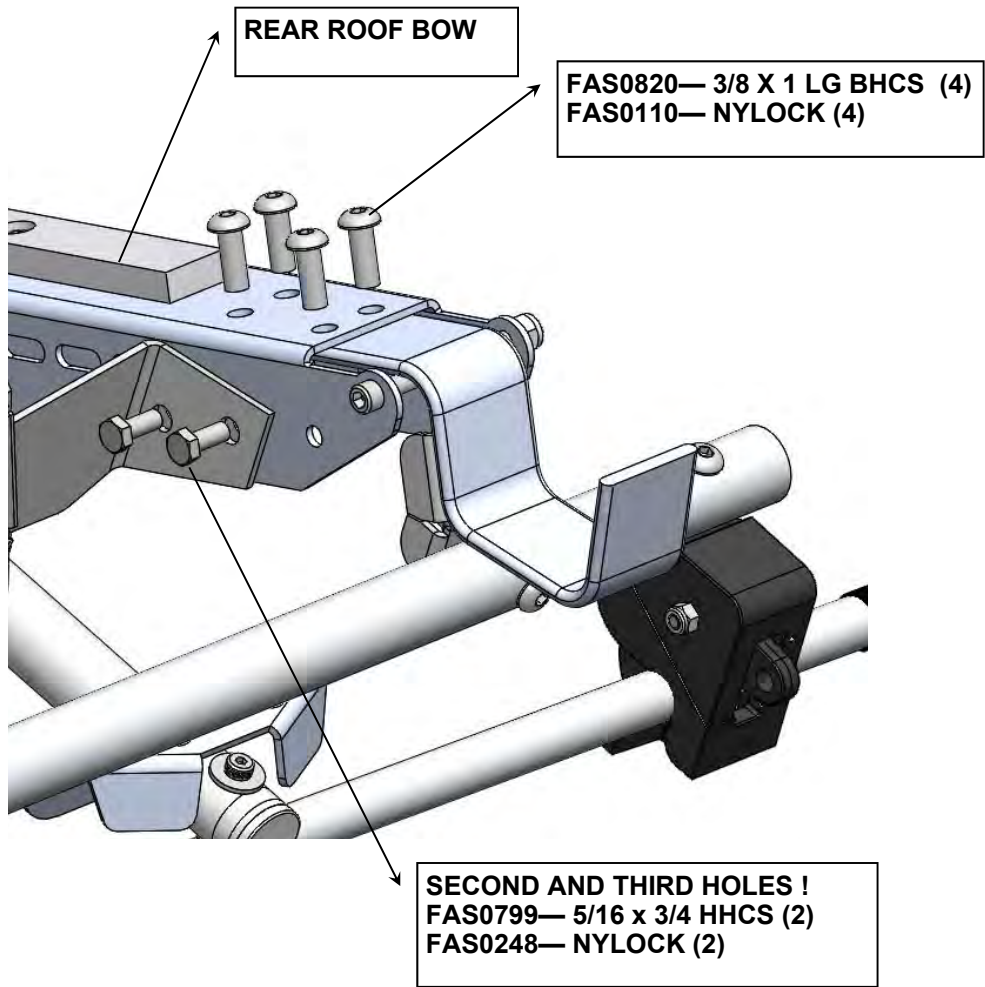
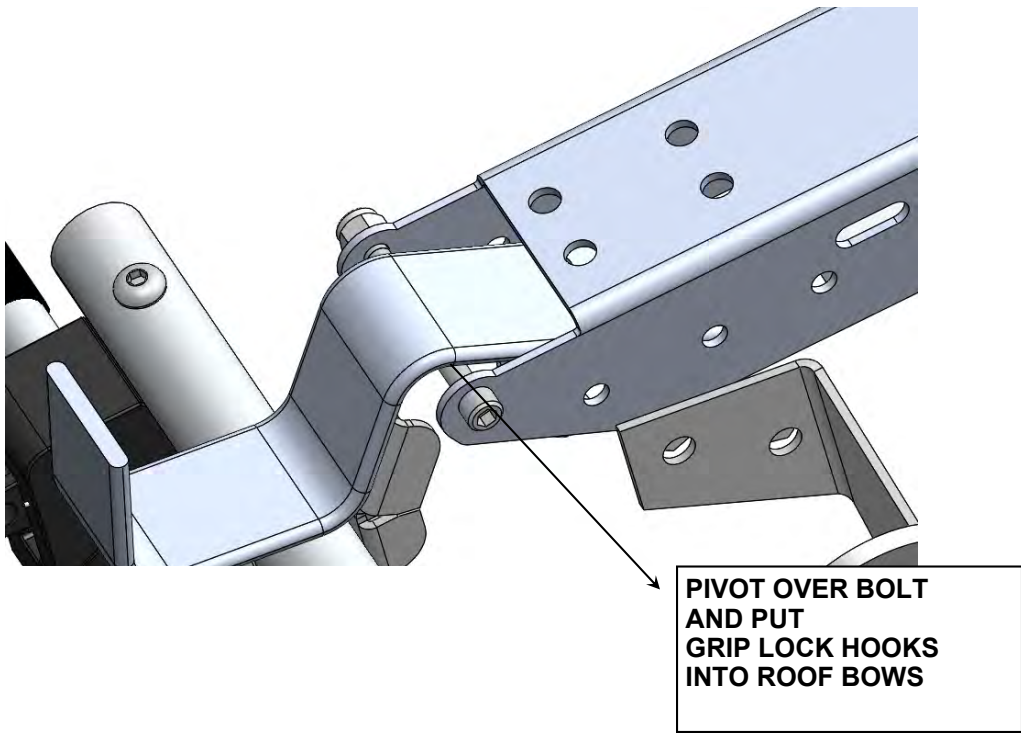



STEP #19: FRONT ROOF BOW ASSEMBLY –STREET SIDE

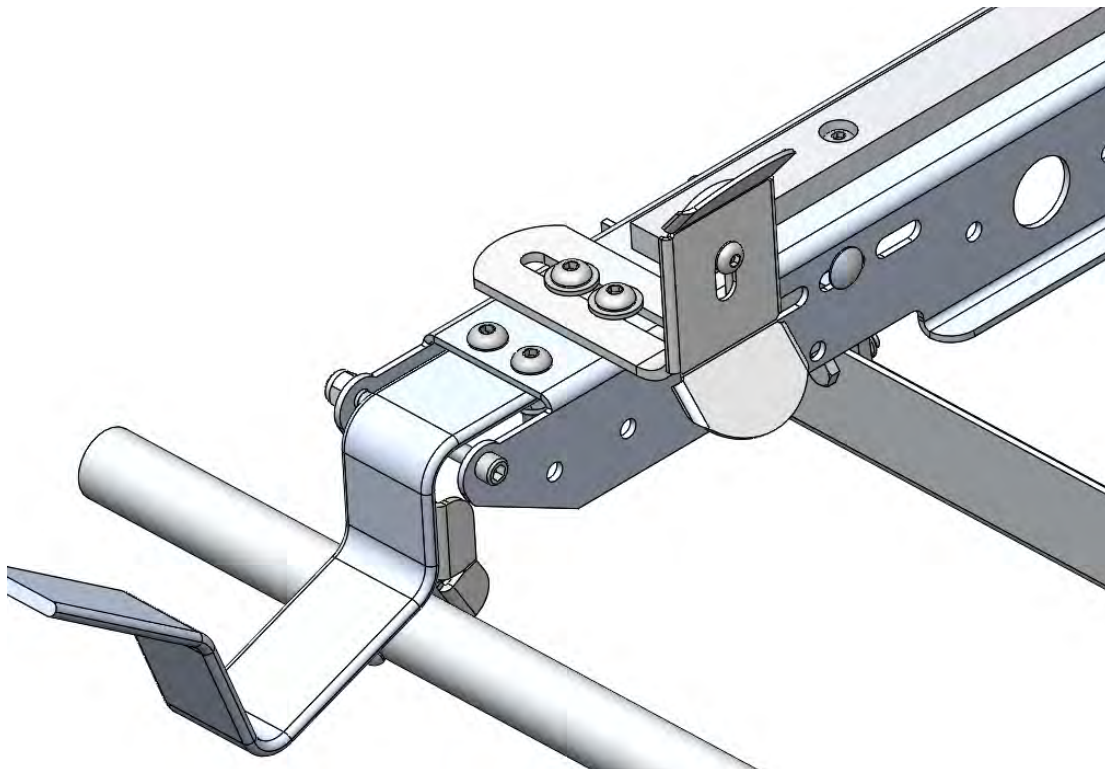
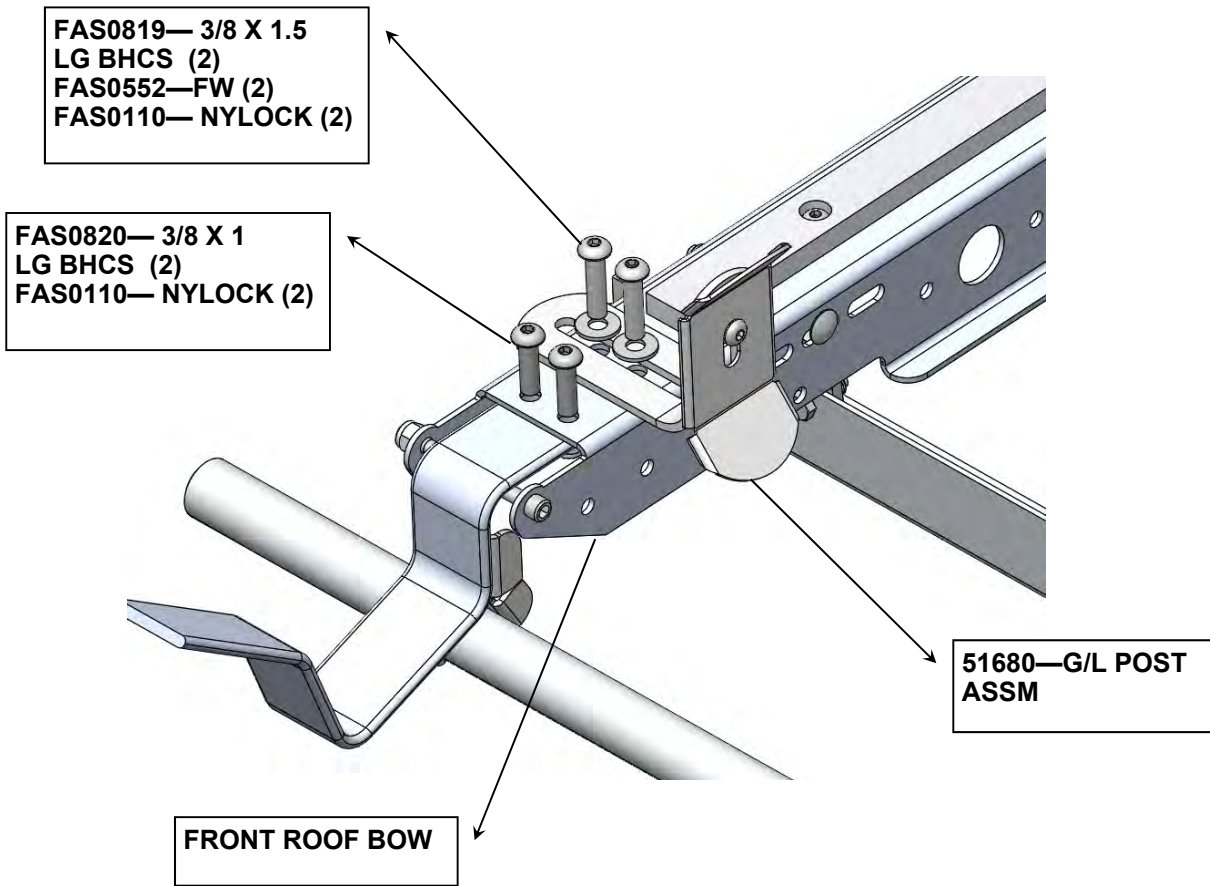



STEP #23 : YOUR DROP DOWN COMBO INSTALLATION IS NOW COMPLETE



**DOUBLE CHECK ALL FASTENERS LOCATIONS TO BE SURE THAT ALL
FASTENERS ARE TIGHTENED TO SPECIFICATIONS.
YOUR INSTALLATION IS NOW COMPLETE!
STOW THIS COPY IN THE VEHICLE FOR FUTURE REFERENCES!**



**REAR CLAMP PAD MOVES TOWARDS CURB TO
TIGHTEN LADDER TO RACK**

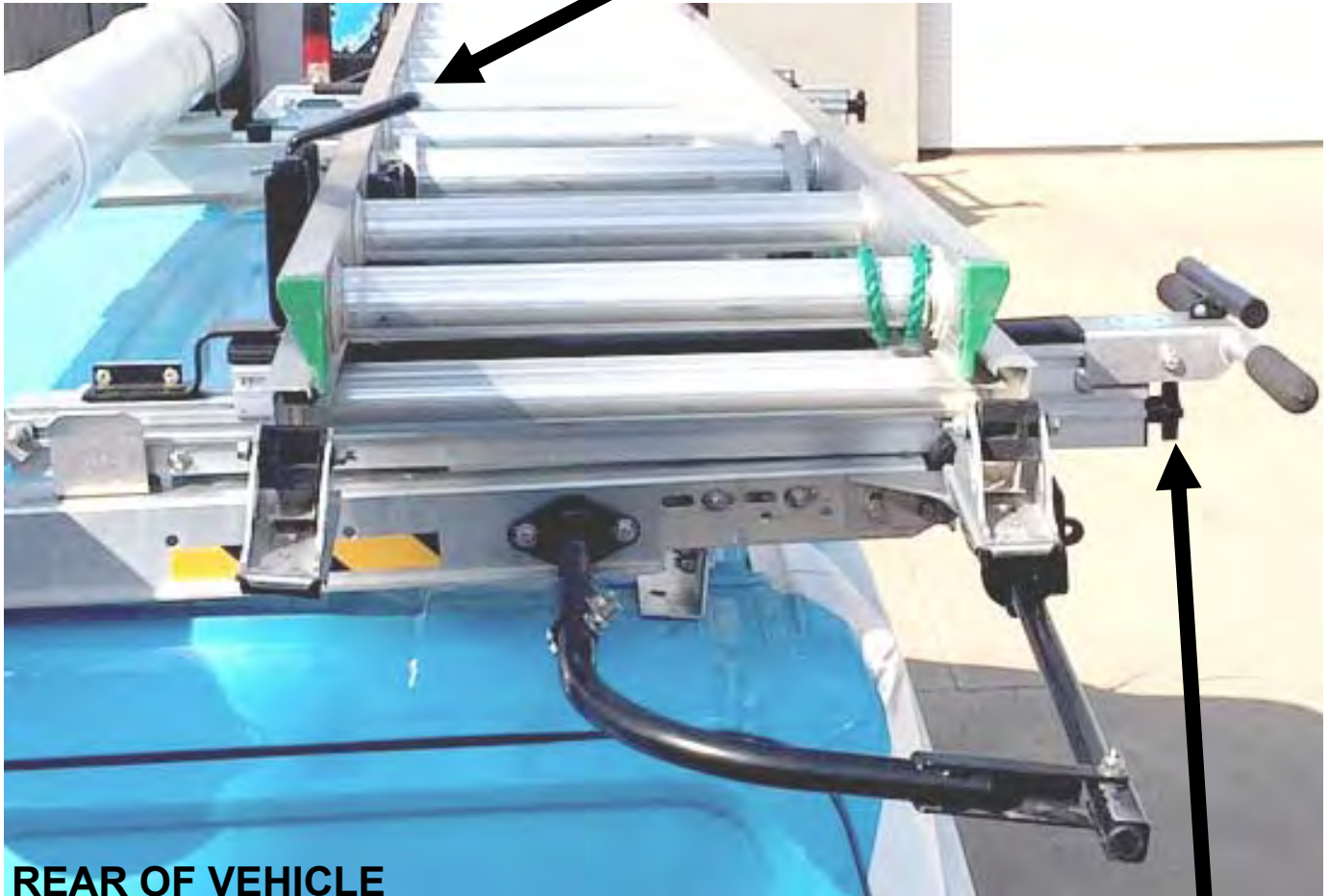

REAR OF VEHICLE



**TURN KNOB TO ADJUST TO
YOUR LADDER.**

**DO NOT OVER TIGHTEN!
CLAMP PAD SHOULD JUST
TOUCH THE LADDER.**

Proper Clamp Pad Locations

Below is the proper way to clamp the ladder to the vehicle (highlighted in green)

How to inspect for this: Properly placed clamp pads should be in close proximity to each other to allow the clamp pads to securely retain the ladder from side to side motion and front to back motion.

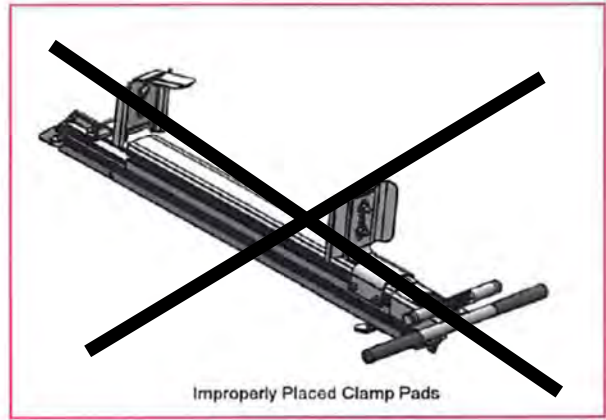
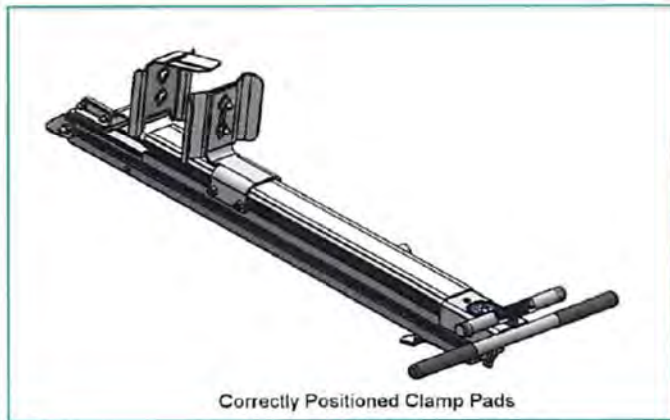

Above is the wrong way to clamp the ladder to the vehicle

**FRONT CLAMP PAD MOVES TOWARDS STREET
TO TIGHTEN LADDER TO RACK**



FRONT OF VEHICLE

**TURN KNOB TO ADJUST TO
YOUR LADDER.**

**DO NOT OVER TIGHTEN!
CLAMP PAD SHOULD JUST
TOUCH THE LADDER.**



DDL61 Series Final Adjustment Instruction (GMFSV / Ford Transit)

**DOUBLE CHECK ALL FASTENERS LOCATIONS TO BE SURE THAT ALL FASTENERS ARE
TIGHTENED TO SPECIFICATIONS.**

YOUR INSTALLATION IS NOW COMPLETE!

STOW THIS COPY IN THE VEHICLE FOR FUTURE REFERENCES!

Introduction / Comments:

THIS DROP DOWN UNIT IS CURB SIDE, STREET SIDE SPECIFIC. THE DROP DOWN IS FOR LOW ROOF VEHICLES, THESE INSTRUCTIONS WILL BE SHOWING THE GM FSV AND SOME FORD TRANSIT PICTURES FOR THE VEHICLE REPRESENTATION. THIS DROP DOWN LADDER RACK IS DESIGNED TO ADAPT TO AN ADRIAN STEEL CROSS BOW KIT FOR VARIOUS STANDARD ROOF VEHICLES.

Note:

It is advised that all fasteners used in this assembly and installation of this Rack should be checked for tightness at the following intervals: @ 2-weeks and again @ 6-weeks of operation. This preventive maintenance step must be completed to ensure your package gives you long service life.

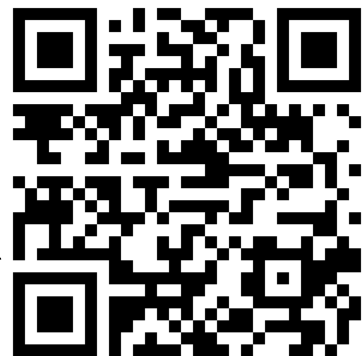
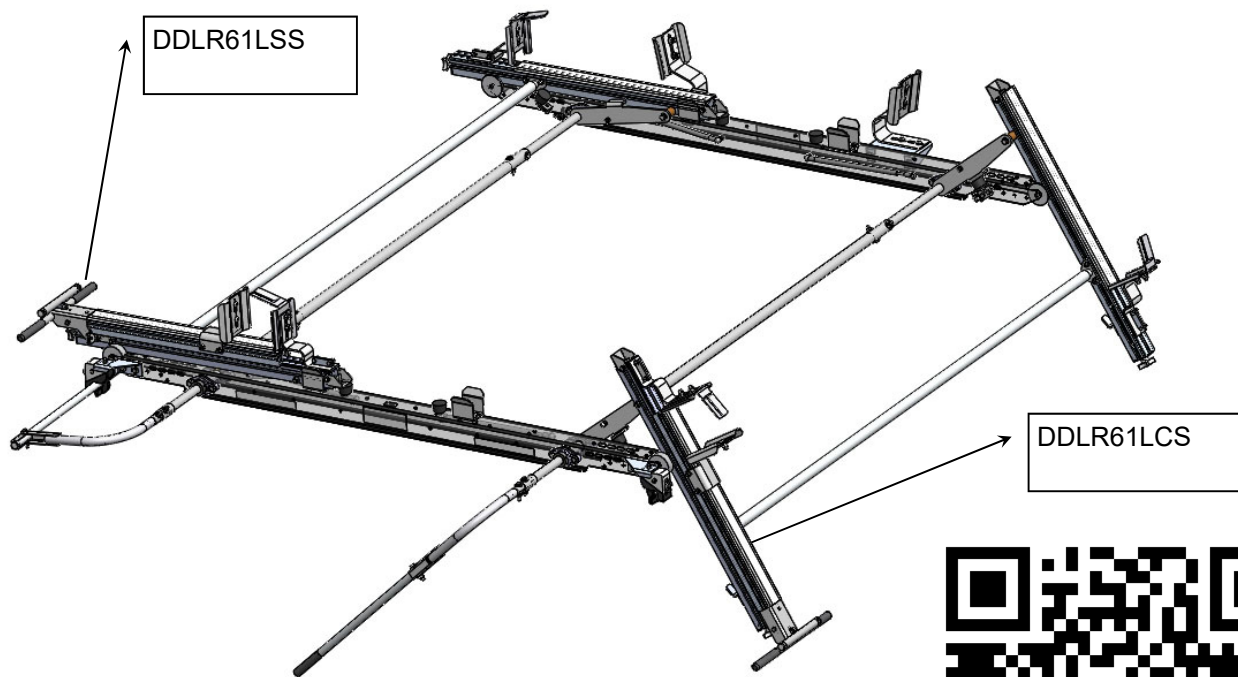

TO VIEW INSTALL VIDEO

**DDL61GM / DDL63GM
FINAL DROP DOWN LADDER RACK, STREET, CURB
GM FSV, LOW ROOF VAN**

- PRECAUTIONS -





 **CAUTION** 
**THE USE OF AIR IMPACT TOOLS CAN
OVER-TORQUE FASTENERS AND
CAUSE FASTENER FAILURE!**



 **CAUTION** 
**ALL INSTALLATION HOLES SHOULD BE SEALED
WITH SILICON OR BUTYL SEALANT TO PREVENT
EXHAUST FUMES FROM ENTERING THE VEHICLE!**



 **DANGER** 
**INSPECT FOR FUEL TANK, FUEL LINES, BRAKE LINES, HIGH
VOLTAGE BATTERIES AND ELECTRICAL LINES PRIOR TO
DRILLING TO AVOID DAMAGING CRITICAL VEHICLE SYSTEMS
OR INJURY TO INSTALLER DURING INSTALLATION PROCESS!**



 **CAUTION** 
**TO AVOID DAMAGING THE VEHICLE ALWAYS
USE DRILL STOPS WHEN DRILLING ANY IN-
STALLATION HOLES!**



- IMPORTANT WARRANTY REQUIREMENTS -

1. SUBSTITUTING ADRIAN STEEL SPECIFIED FASTENERS FOR ASSEMBLY AND/OR INSTALLATION WILL VOID YOUR PRODUCT WARRANTY.
2. ALL HOLES DRILLED INTO VEHICLE SHOULD HAVE THE RAW METAL EDGES SEALED WITH A SELF-ETCHING PRIMER TO RESIST CORROSION AND POTENTIAL FASTENER POINT FAILURE.
3. ALL FASTENERS USED IN THE INSTALLATION OF THIS PRODUCT SHOULD BE TIGHTENED TO THE TORQUE(S) SPECIFIED IN THESE INSTRUCTIONS.
4. THESE INSTRUCTIONS SHOULD BE KEPT WITH THE VEHICLE.

THE BASIC TOOLS NEEDED FOR MOST INSTALLATIONS



DRILL



DRILL BIT WITH
STOP

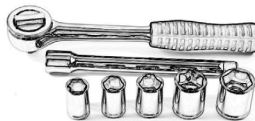

RATCHET, SOCKETS
AND/OR WRENCHES



SCREWDRIVERS



MEASURING TAPE

ADDITIONAL TOOLS MAY BE NEEDED FOR THIS INSTALLATION AND THEY WILL BE IDENTIFIED IN THE STEPS THAT FOLLOW.

BAG51041—FINAL ASSEMBLY FASTENER BAG

ITEM NO.	PART NUMBER	DESCRIPTION	QTY.
1	BAG0507-A	5" x 7" 3MIL AUTOBAG	1
2	FAS0246	Washer, Flat, 3/8, HRD, ZN	6
3	FAS0799	Screw, Hex Hd, 5/16-18x0.75 SS	4
4	FAS0110	Nut,Hex Nylk 3/8-16 SS W	4
5	FAS0572	Screw, Button Hd Hex Soc, 3/8-16x1.00 NI-ZN	2
6	FAS0588	Washer, Lock, Split, 5/16, SS	4
7	FAS0286	SCREW, HHCS, 3/8-16x4, SS	2
8	FAS0287	COTTER PIN, 1/16DIA X 1"LG, SS	2

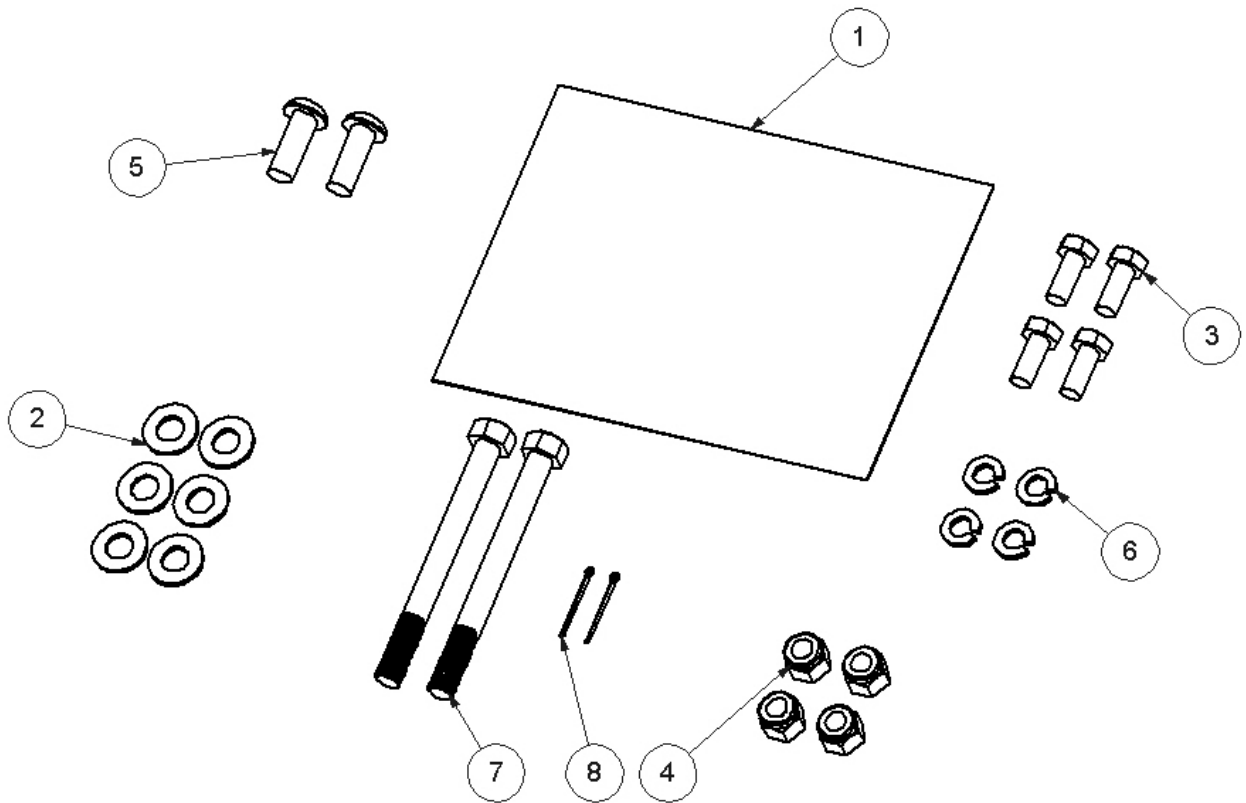



STEP 1A : THIS IS THE SHIP THRU SINGLE DROP DOWN AS YOU WOULD RECEIVE FOR FINAL DEALER ASSEMBLY. SEE STEP 1B FOR DOUBLE DROP DOWN.

SHOWING A GM FSV
RRKGMFSV
CROSS BOW KIT
ORDERED
SEPERATELY





STEP 1B : THIS IS THE SHIP THRU DOUBLE DROP DOWN AS YOU WOULD RECEIVE FOR FINAL DEALER ASSEMBLY

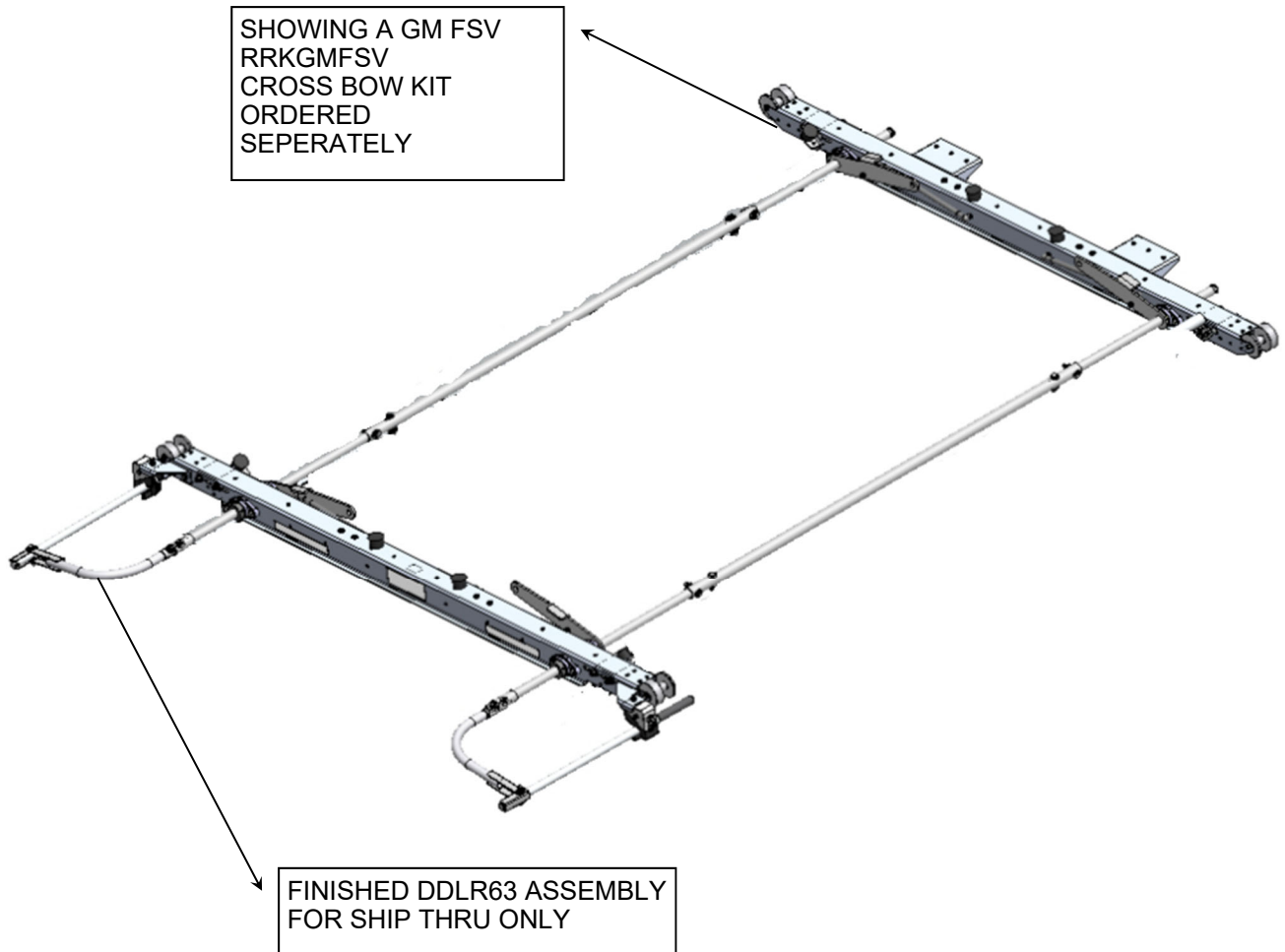

STEP 2 - THIS IS THE FINAL ASSEMBLY, SHOWING THE CURB AND STREET SIDE DROP DOWN COMPONENTS

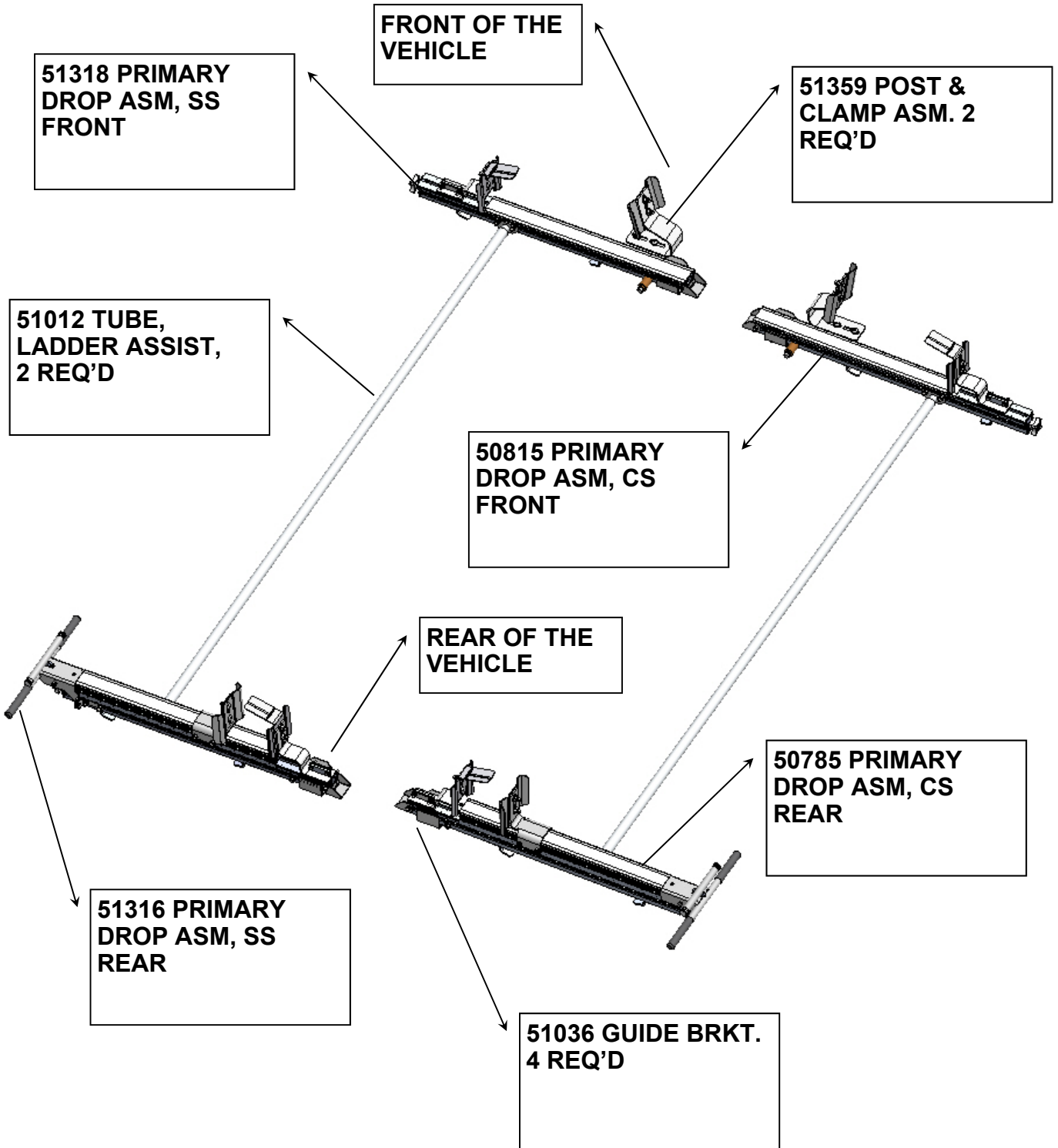

STEP 3 : ASSEMBLE BRACKETS TO THE FRONT CROSS BOW

NOTE: ITEM 51036 WILL VARY APPEARANCE AS EITHER VIEW OF 54178 SHOWN BELOW.

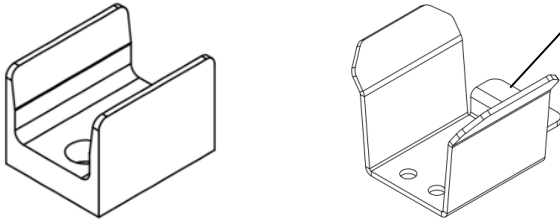

IF USING THIS STYLE, ENSURE THE REST FLANGE IS MOUNTING FACING TO THE OUTSIDE OF THE LADDER RACK! THIS WILL GIVE CLEARANCE FOR A CONDUIT KIT TO BE MOUNTED IN THE CENTER.

FAS0799— 5/16 X .75 HHCS
FAS0588— 5/16 LW
(2) EACH, 4 PLACES
THRU FRONT HOLES OF FRONT BRKTS AND REAR HOLES FOR REAR BRKTS INTO RIVNUTS IN CROSS BOWS

51359 POST & CLAMP
ASM
2 PLACES

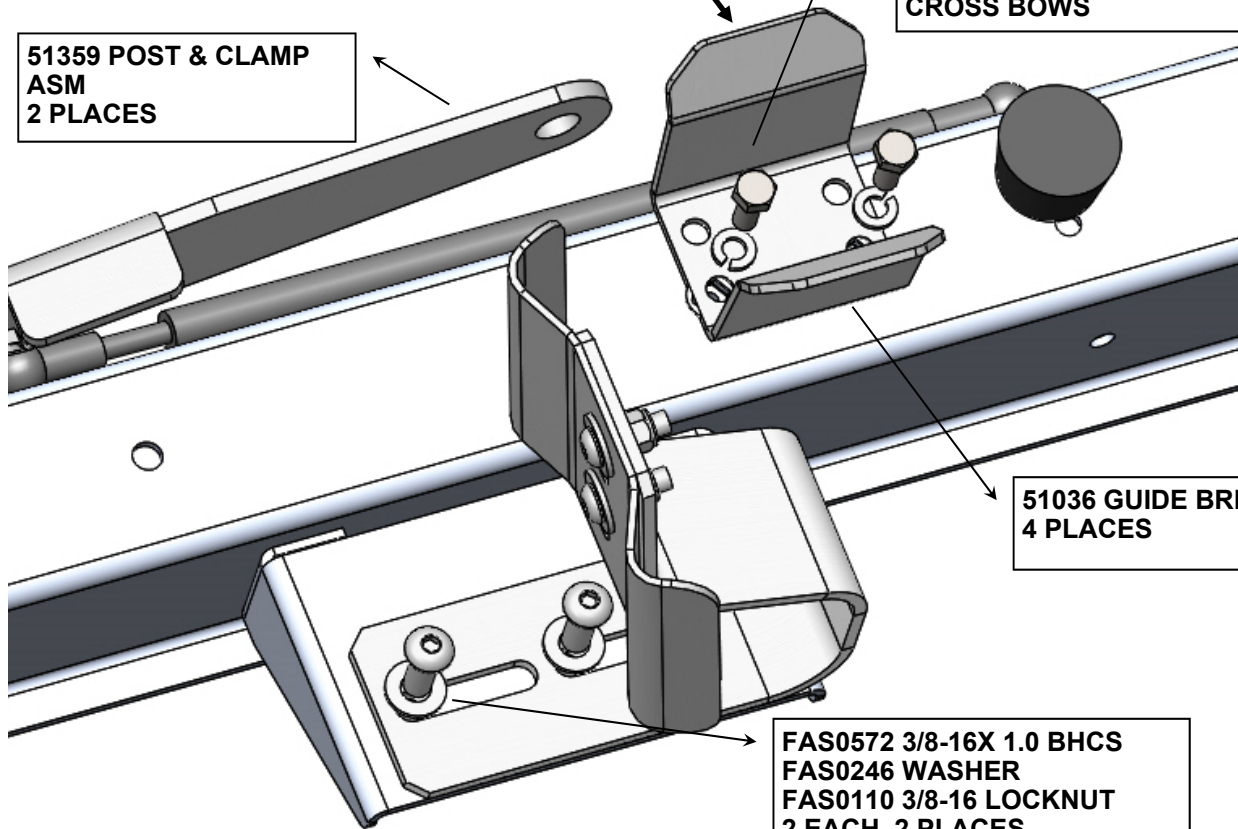

51036 GUIDE BRKT
4 PLACES

FAS0572 3/8-16X 1.0 BHCS
FAS0246 WASHER
FAS0110 3/8-16 LOCKNUT
2 EACH, 2 PLACES

COMPLETED VIEW OF THE FRONT CROSS BOW

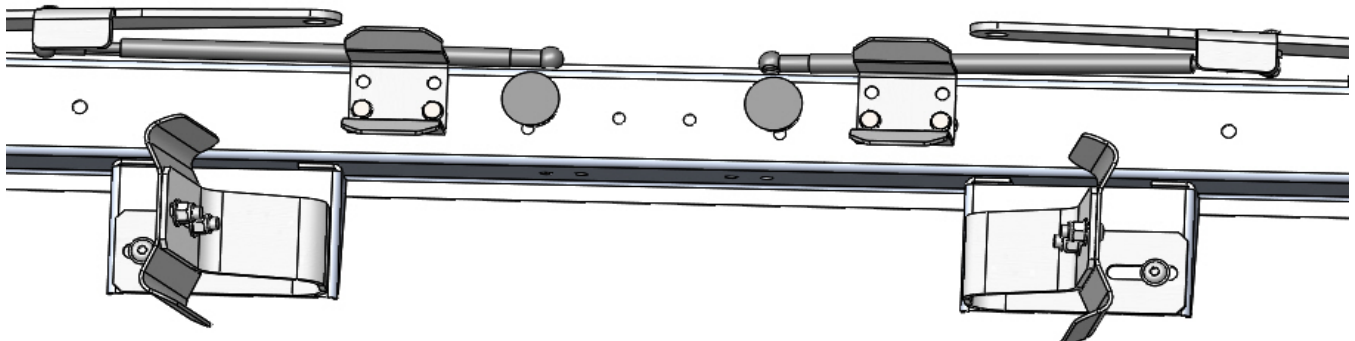

STEP 4 : ASSEMBLE REAR CURB SIDE PRIMARY DROP TO RACK

**SET 50785 PRIMARY DROP ASM, REAR CS IN PLACE ON REAR CROSS BOW.
USE GUIDE ROLLER TO HELP LOAD INTO POSITION**

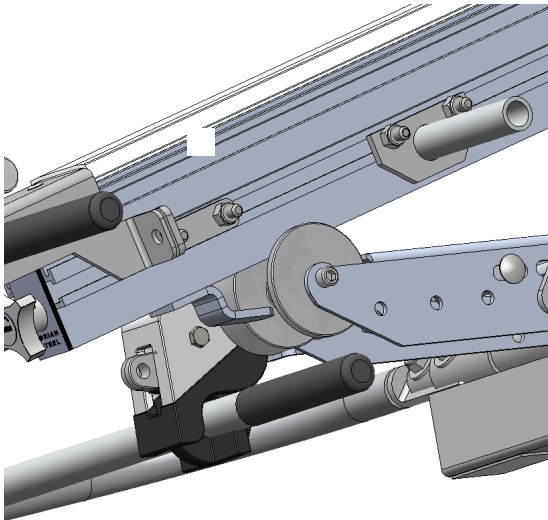

**50785 PRIMARY DROP
ASM CS REAR**

**50785 PRIMARY DROP
ASM, CS REAR**

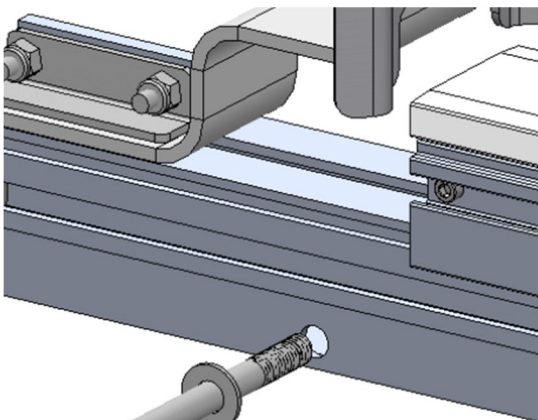
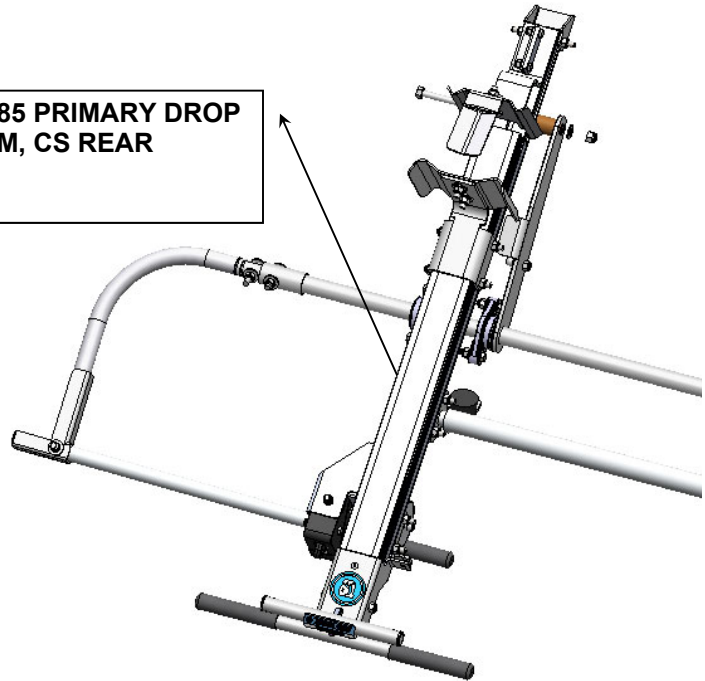

**FAS02826 3/8-16 X 4" HHCS
FAS0246 WASHER**

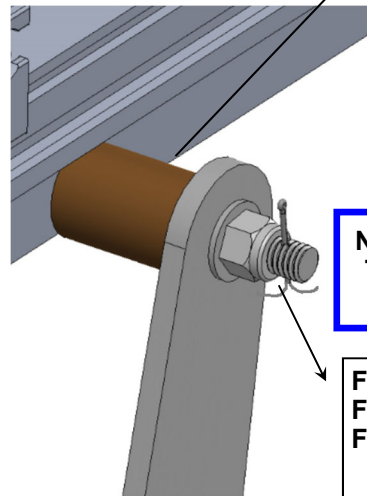

**51034 BRONZE
BUSHING**

**NOTE: TORQUE NYLOCK NUT
TO 20FT.LBS, THEN INSERT/
SECURE THE COTTER PIN.**

**FAS0246 WASHER
FAS0110 3/8-16 NYLOCK NUT
FAS0287—COTTER PIN**

**NOTE: AFTER THE COTTER
PIN IS INSERTED THROUGH
THE BOLT, SPREAD THE PIN
SO IT CAN NOT BE REMOVED.**

STEP 5 : ASSEMBLE FRONT SIDE PRIMARY DROP TO RACK

**SET 50815 PRIMARY DROP ASM, FRONT CS IN PLACE ON FRONT CROSS BOW.
USE GUIDE ROLLER AFTER LADDER ASSIST TUBE IS ON BOTH STUB SHAFTS**

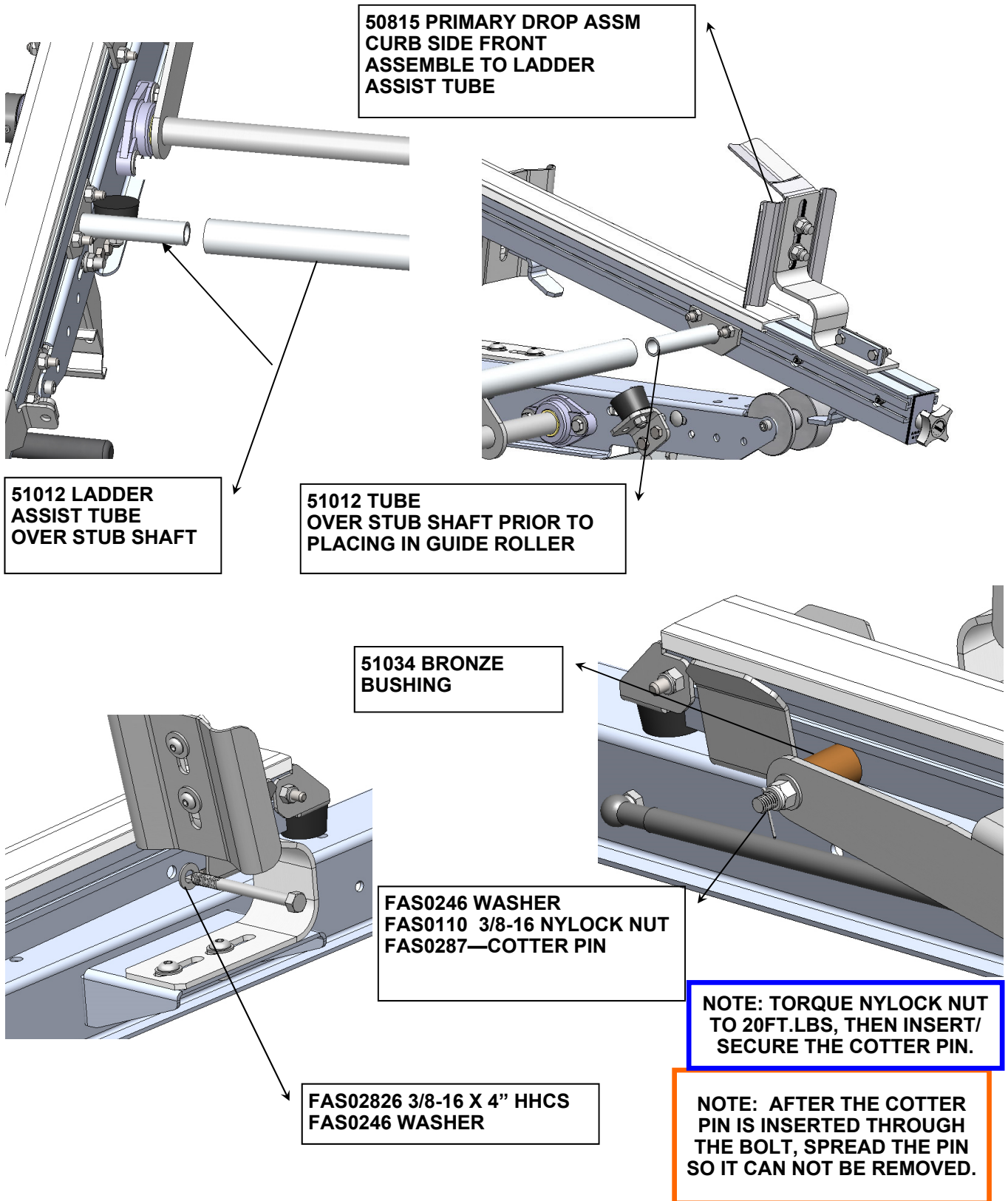



**STEP #6 : FOR A DOUBLE DROP DOWN, INSTALL STREET SIDE USING
STEPS #4 & #5 AS YOUR GUIDE.**

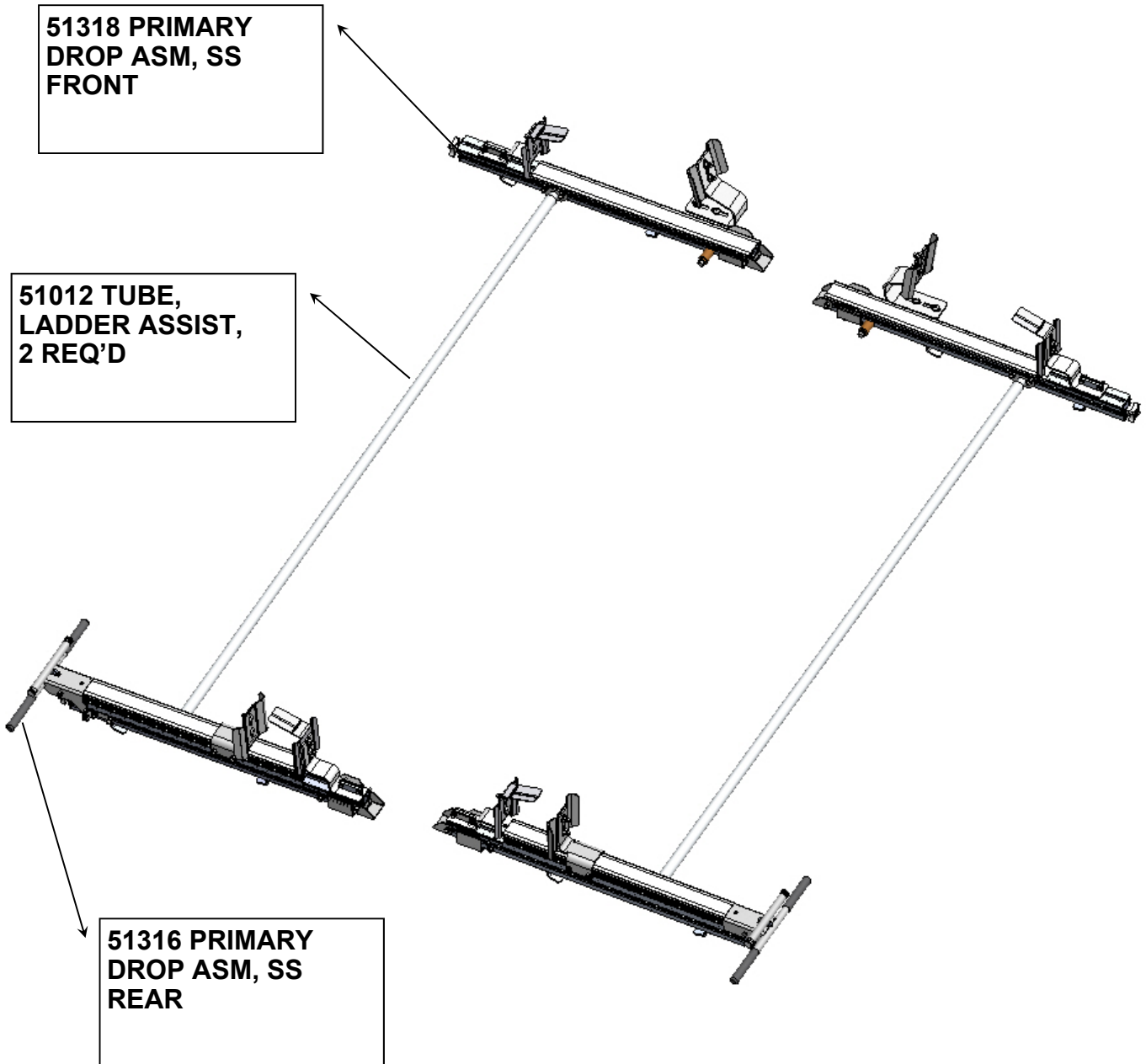

**DOUBLE CHECK ALL FASTENERS LOCATIONS TO BE SURE THAT ALL
FASTENERS ARE TIGHTENED TO SPECIFICATIONS.
YOUR INSTALLATION IS NOW COMPLETE!
STOW THIS COPY IN THE VEHICLE FOR FUTURE REFERENCES!**



**STEP #7 : YOUR DOUBLE DROP DOWN INSTALLATION IS NOW COMPLETE
FOR A COMBO RACK, GO TO STEP 8**



**DOUBLE CHECK ALL FASTENERS LOCATIONS TO BE SURE THAT ALL
FASTENERS ARE TIGHTENED TO SPECIFICATIONS.
YOUR INSTALLATION IS NOW COMPLETE!
STOW THIS COPY IN THE VEHICLE FOR FUTURE REFERENCES!**



STEP #08 : COMBO RACK, FINAL INSTALL- STREET SIDE GRIP LOCK



STEP #9 : COMBO RACK, INSTALL STREET SIDE GRIP LOCK

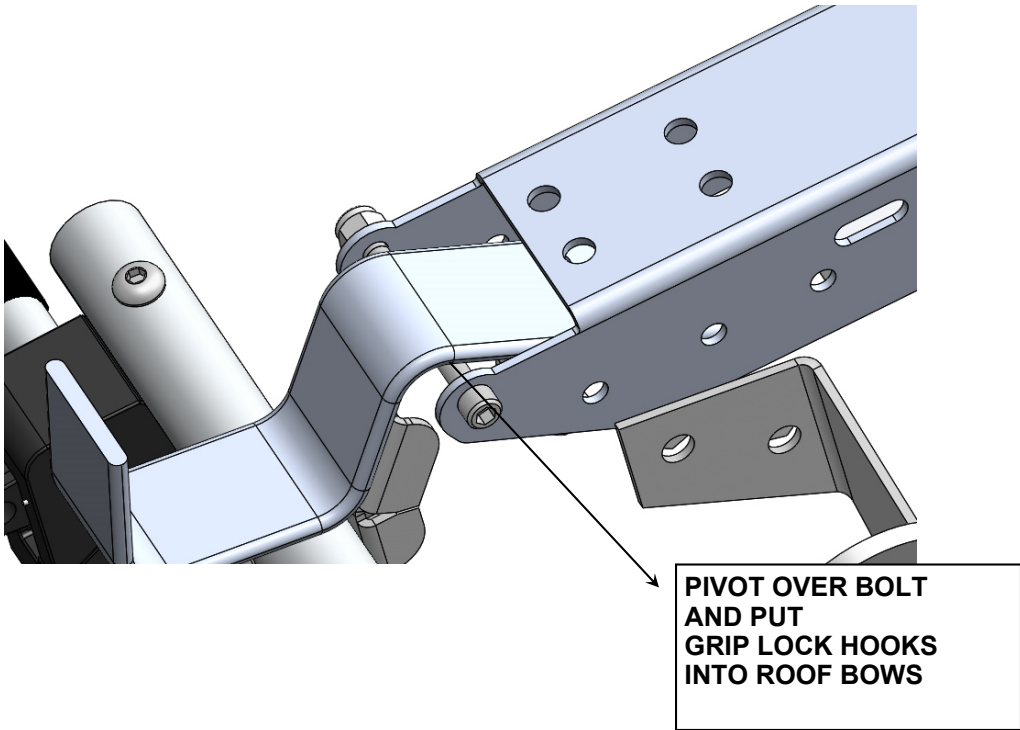

SECOND AND THIRD HOLES !
FAS0799— 5/16 x 3/4 HHCS (2)
FAS0248— NYLOCK (2)

REAR ROOF BOW

FAS0820— 3/8 X 1 LG BHCS (4)
FAS0110— NYLOCK (4)

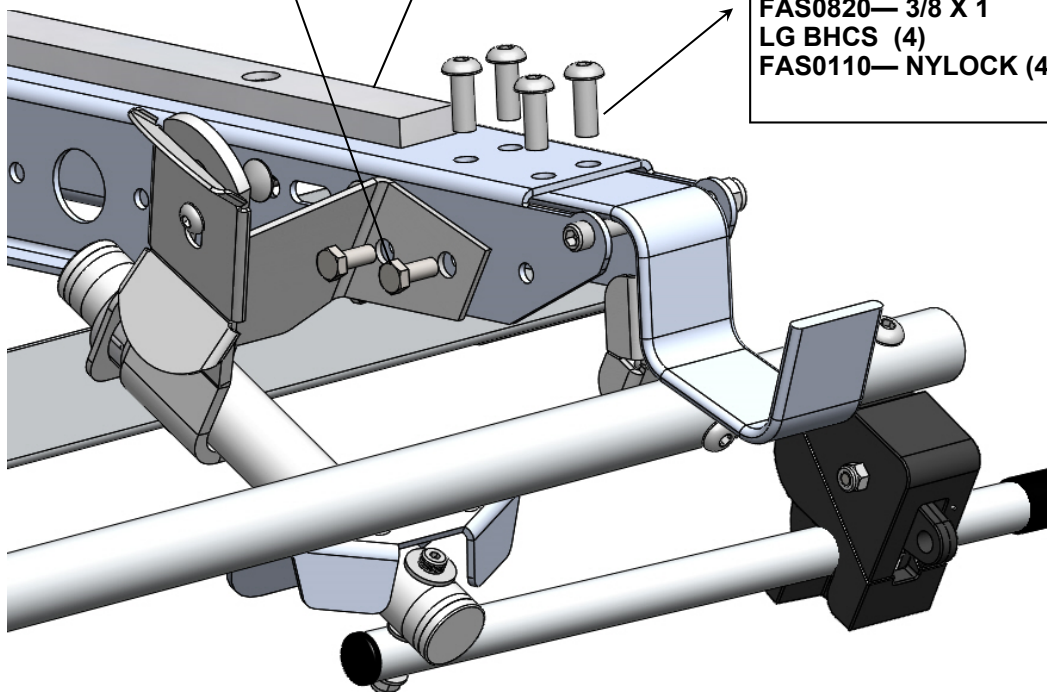

STEP #10: FRONT ROOF BOW ASSEMBLY –STREET SIDE

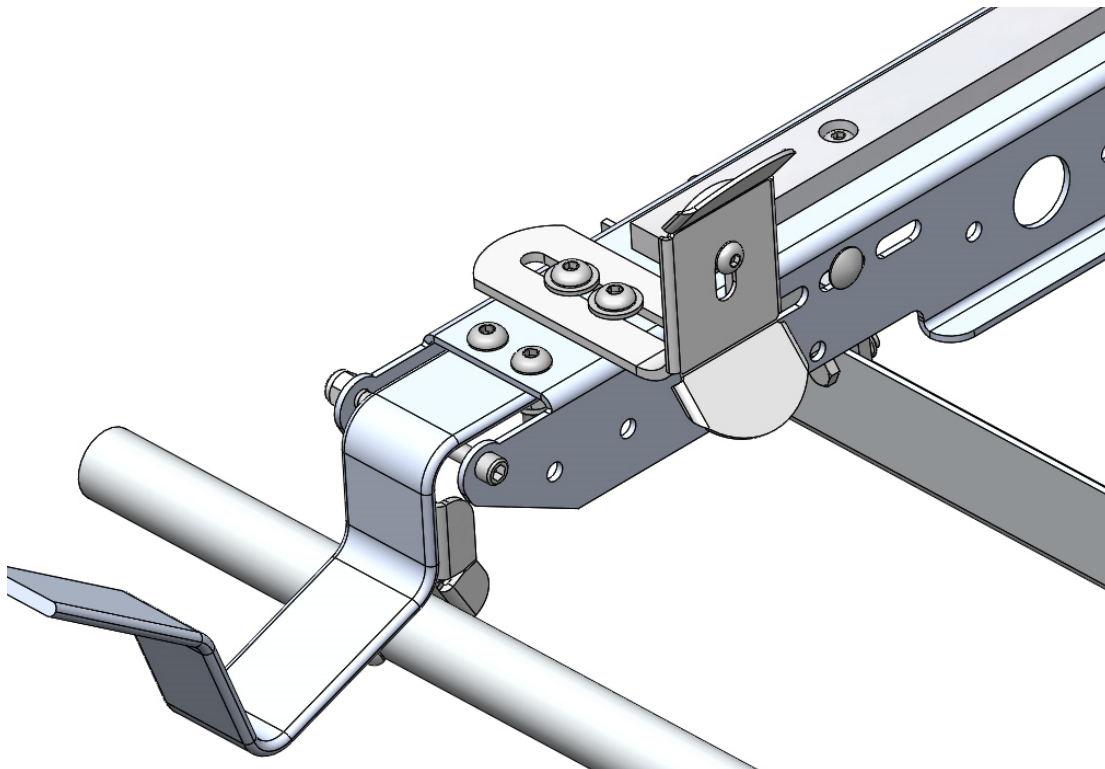
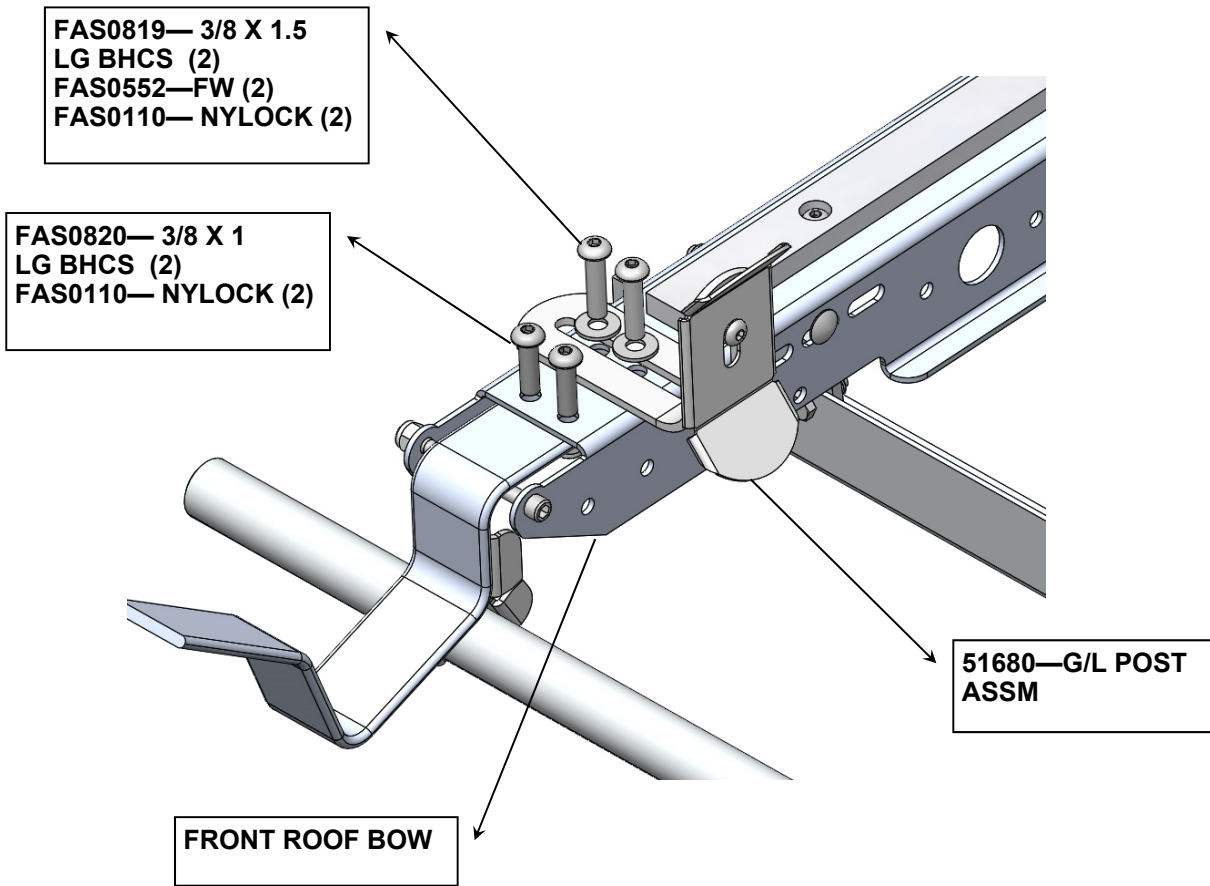

STEP #23 : YOUR DROP DOWN COMBO INSTALLATION IS NOW COMPLETE



**DOUBLE CHECK ALL FASTENERS LOCATIONS TO BE SURE THAT ALL
FASTENERS ARE TIGHTENED TO SPECIFICATIONS.
YOUR INSTALLATION IS NOW COMPLETE!
STOW THIS COPY IN THE VEHICLE FOR FUTURE REFERENCES!**

**REAR CLAMP PAD MOVES TOWARDS CURB TO
TIGHTEN LADDER TO RACK**

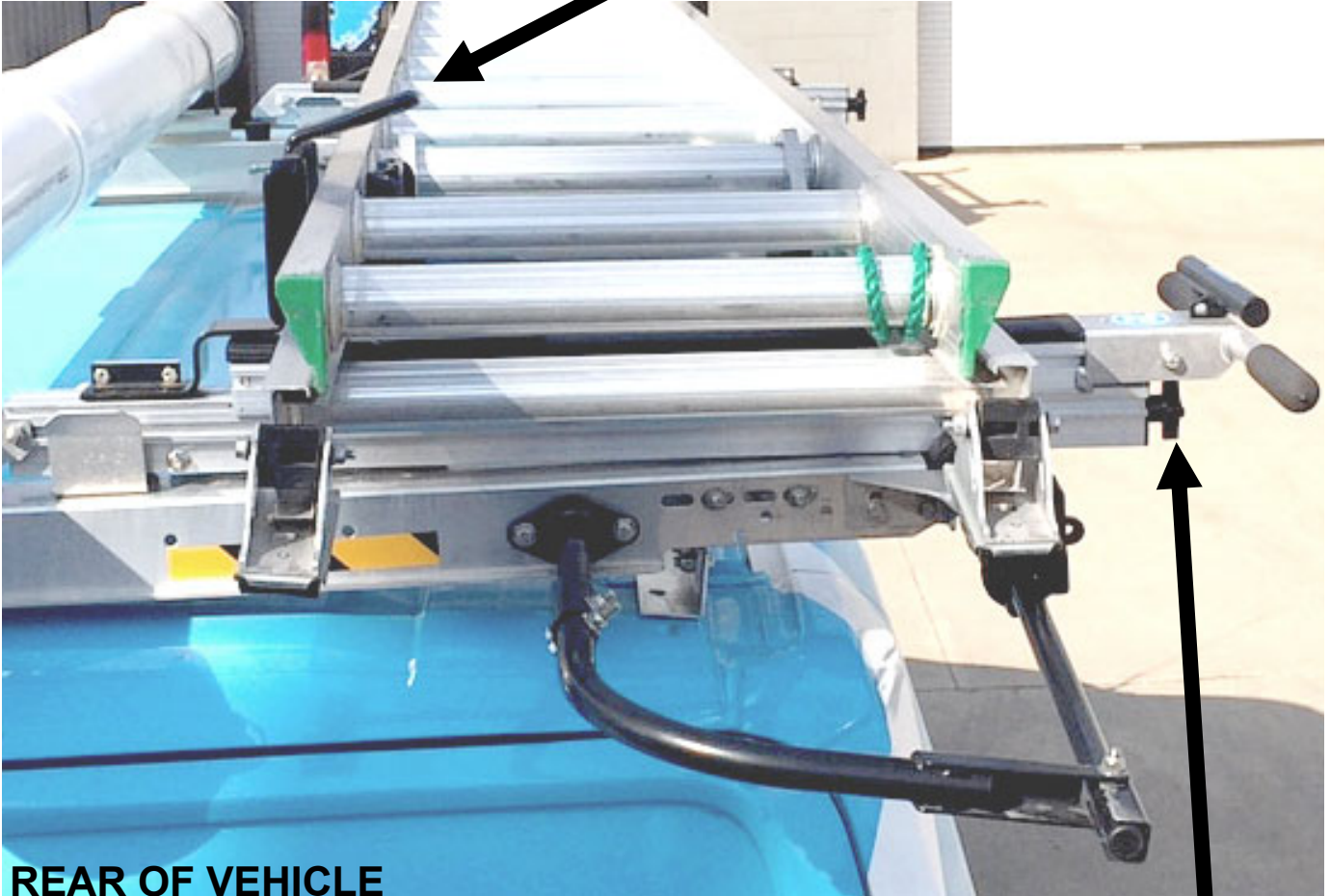

REAR OF VEHICLE

**TURN KNOB TO ADJUST TO
YOUR LADDER.**

**DO NOT OVER TIGHTEN!
CLAMP PAD SHOULD JUST
TOUCH THE LADDER.**



DDL61 Series Final Adjustment Instruction (GMFSV / Ford Transit)

Proper Clamp Pad Locations

Below is the proper way to clamp the ladder to the vehicle (highlighted in green)

How to inspect for this: Properly placed clamp pads should be in close proximity to each other to allow the clamp pads to securely retain the ladder from side to side motion and front to back motion.

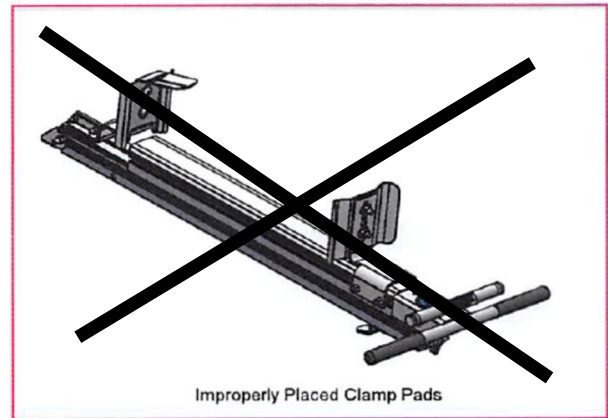
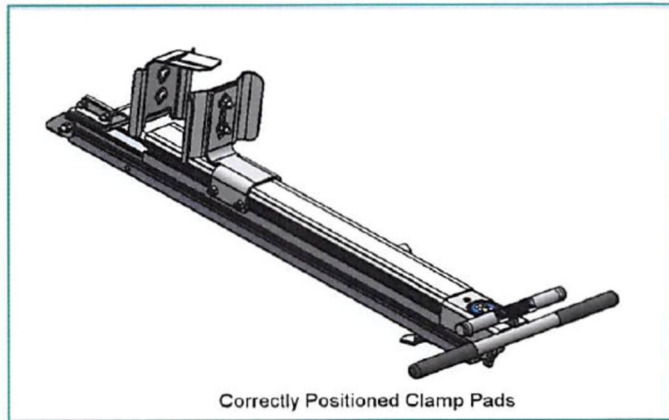

Above is the wrong way to clamp the ladder to the vehicle

**FRONT CLAMP PAD MOVES TOWARDS STREET
TO TIGHTEN LADDER TO RACK**



**TURN KNOB TO ADJUST TO
YOUR LADDER.**

**DO NOT OVER TIGHTEN!
CLAMP PAD SHOULD JUST
TOUCH THE LADDER.**



DDL61 Series Final Adjustment Instruction (GMFSV / Ford Transit)

**DOUBLE CHECK ALL FASTENERS LOCATIONS TO BE SURE THAT ALL FASTENERS ARE
TIGHTENED TO SPECIFICATIONS.**

YOUR INSTALLATION IS NOW COMPLETE!

STOW THIS COPY IN THE VEHICLE FOR FUTURE REFERENCES!

STEP #10A: HOW TO ADJUST THE CLAMP PADS

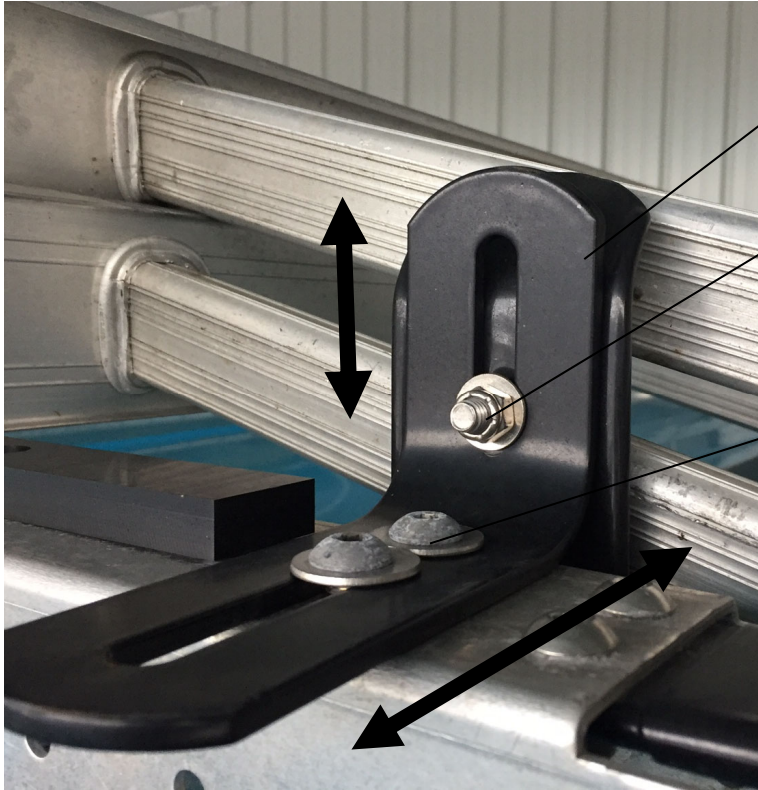

FRONT BRACKET

ADJUST VERTICALLY TO YOUR LADDER

ALL OF THE HORIZONTAL ADJUSTMENT IS IN THIS BRACKET.

REAR LOCKING PIVOT BRACKET

ADJUST VERTICALLY TO YOUR LADDER. SHOWING A STEP LADDER

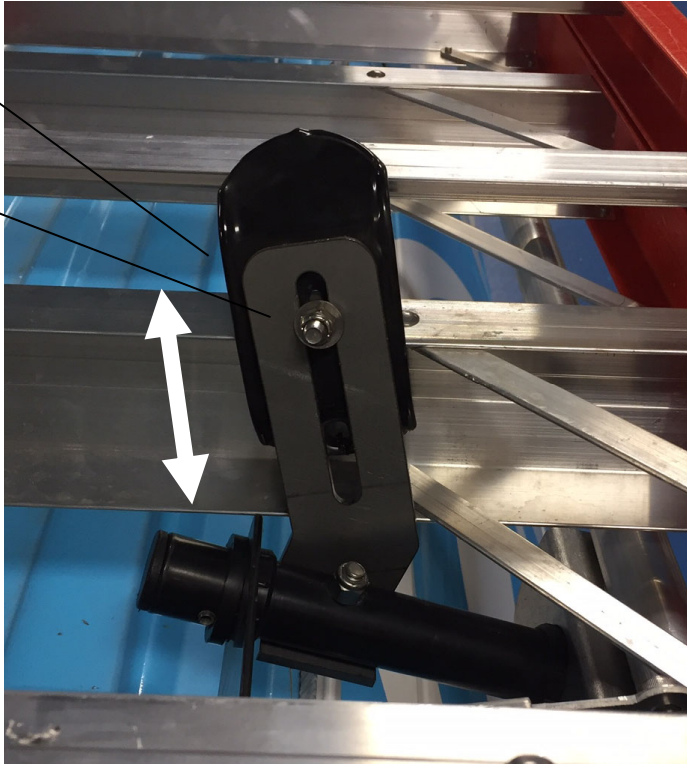

**DOUBLE CHECK ALL FASTENERS LOCATIONS TO BE SURE THAT ALL FASTENERS ARE TIGHTENED TO SPECIFICATIONS.
YOUR INSTALLATION IS NOW COMPLETE!
STOW THIS COPY IN THE VEHICLE FOR FUTURE REFERENCES!**

STEP #10B : HOW TO ADJUST THE CLAMP PADS

- A) Load your ladder onto the ladder rack (see page 14) and latch the HANDLE BAR into the HANDLE LATCH.
- B) Now slide the ladder back towards the rear of the vehicle and slide the rear CLAMP BRACKET to fit snug over and against the top ladder rung. ** See bottom illustration for STEP LADDERS ! **
SEE ILLUSTRATION BELOW.
- C) Next slide the FRONT STOP POST at the front of the ladder rack back towards the rear of the vehicle and fit the front CLAMP BRACKET to the top ladder rung the same as the rear.
- D) Firmly tighten both front and rear CLAMP BRACKETS to their posts and tighten snug the FRONT STOP POST to the front CROSS SUPPORT.
- E) Now unlatch the HANDLE BAR and unload your ladder. Next loosen the FRONT STOP POST and slide it out towards the rear of the vehicle 1/2" and FIRMLY RETIGHTEN !
YOUR LADDER RACK SHOULD NOW BE ADJUSTED FOR YOUR LADDER.

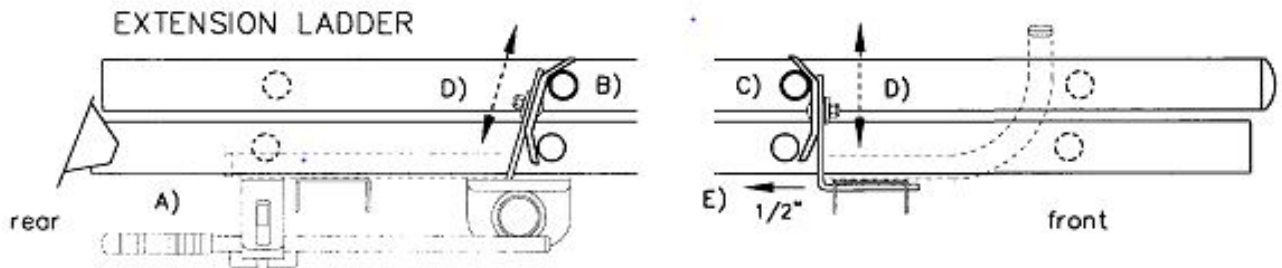

CAUTION: Never clamp up the first step and the head of the STEP LADDER !

Front CLAMP BRACKET must be attached like this !

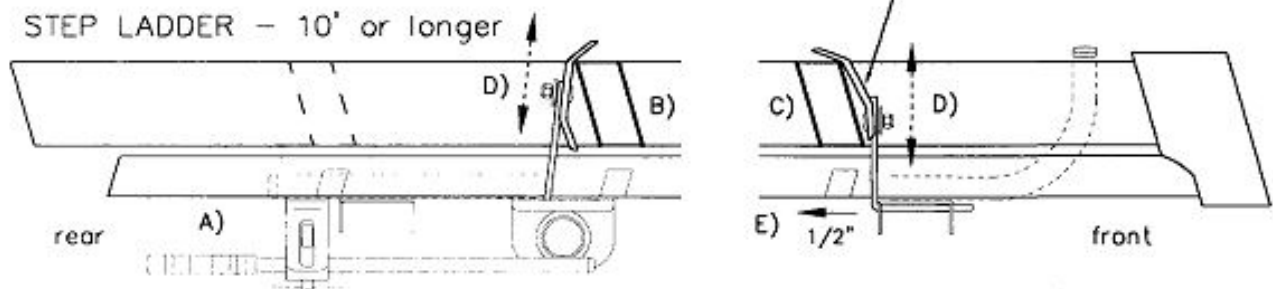

**DOUBLE CHECK ALL FASTENERS LOCATIONS TO BE SURE THAT ALL FASTENERS ARE TIGHTENED TO SPECIFICATIONS.
YOUR INSTALLATION IS NOW COMPLETE!
STOW THIS COPY IN THE VEHICLE FOR FUTURE REFERENCES!**