

PRODUCT WEIGHT
169 lbs

WIDTH x DEPTH x HEIGHT
83" X 106" X 18"

CAPACITY
28 FOOT EXT

COLOR
Aluminum / Black

CATALOG NUMBER
DD63PML118

PRODUCT FEATURES

This drop down rack and roof cross-bow kit is designed to fit the PROMASTER 118" Low Roof. The drop down will carry 20 to 28 foot extension ladders, and 10-12 foot step ladders. Step ladders shorter than 10' require DDLRSLK2 step ladder kit. Step ladders wider than 26" at the base require the wide step ladder add on, part 57107. Ladders with extensive gussets or platform step ladders may not be compatible with the rack.

SEE PAGE 2 FOR APPLICATION NOTES AND ACCESSORIES, OTHER PRODUCTS THAT WORK WITH THIS UNIT.

CATALOG NUMBER DD63PML118

PRODUCT APPLICATION

This Drop down unit is designed to fit the PROMASTER 118"WB Low Roof.

ACCESSORIES THAT WILL WORK WITH THIS PRODUCT

CATALOG NUMBER	DESCRIPTION
DDLRLK2	STEP LADDER KIT
80-1LR 80-2LR	CONDUIT KIT, ALUMINUM
70-1LR 70-2LR	PVC CONDUIT KITS
57107	DDLRLK WIDE STEP LADDER KIT-ADD ON PIECE

SPECIAL APPLICATION NOTES

Introduction / Comments:

THIS DROP DOWN UNIT IS CURB SIDE, STREET SIDE SPECIFIC. THIS DROP DOWN IS FOR THE MID ROOF VEHICLE. THESE INSTRUCTIONS WILL BE SHOWING THE FORD TRANSIT FOR THE VEHICLE REPRESENTATION. THIS DROP DOWN LADDER RACK IS DESIGNED TO ADAPT TO AN ADRIAN STEEL CROSS BOW KIT FOR MID ROOF VEHICLES.

Note:

It is advised that all fasteners used in this assembly and installation of this Rack should be checked for tightness at the following intervals: @ 2-weeks and again @ 6-weeks of operation. This preventive maintenance step must be completed to ensure your package gives you long service life.

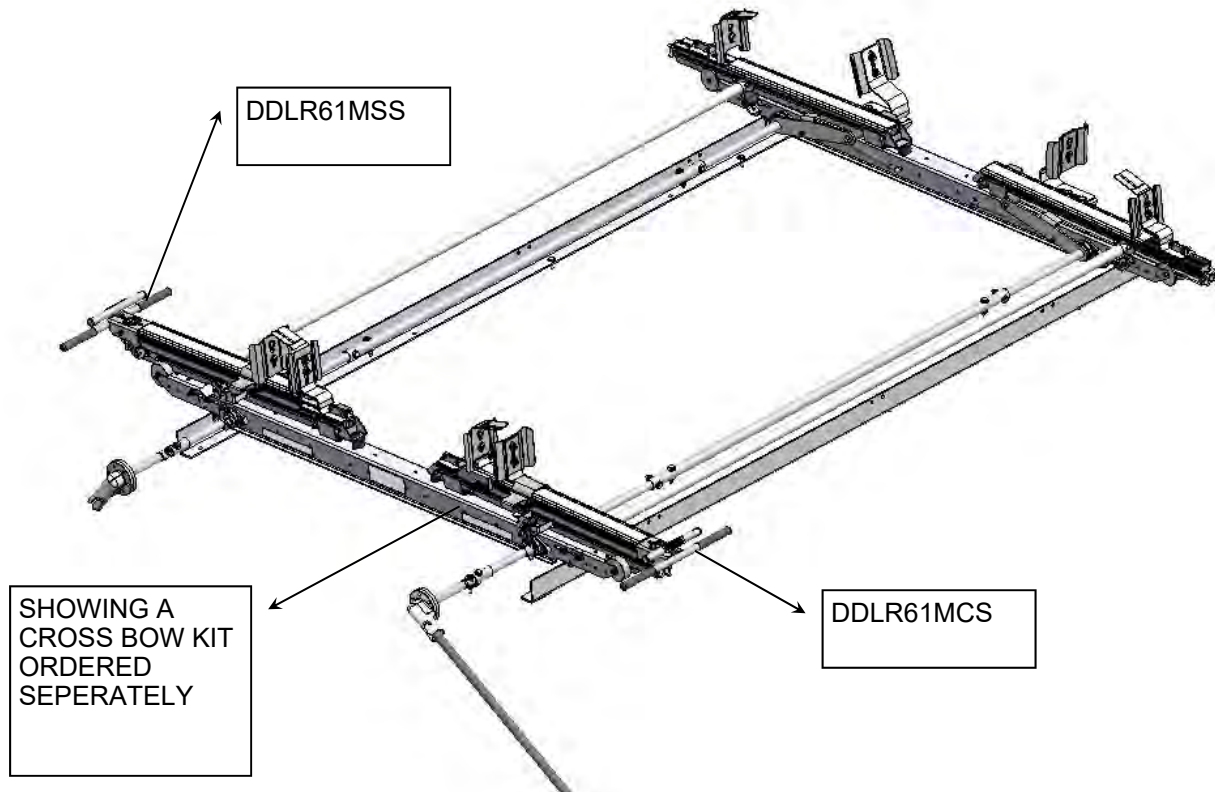

DDL61FTM / DDL63FTM DROP DOWN LADDER RACK, STREET, CURB VARIOUS MID ROOF VANS

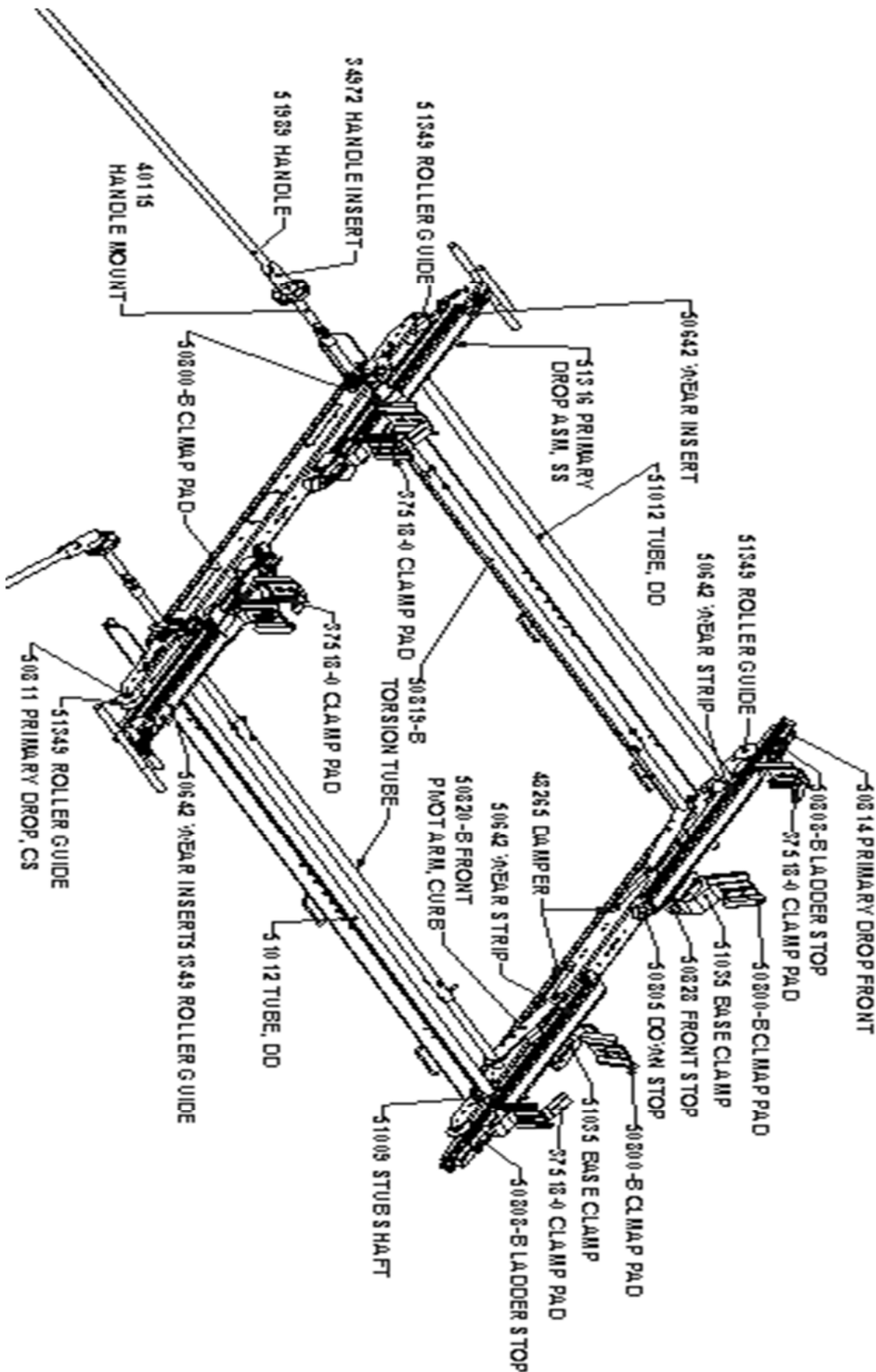

- PRECAUTIONS -





 **CAUTION** 
**THE USE OF AIR IMPACT TOOLS CAN
OVER-TORQUE FASTENERS AND
CAUSE FASTENER FAILURE!**



 **CAUTION** 
**ALL INSTALLATION HOLES SHOULD BE SEALED
WITH SILICON OR BUTYL SEALANT TO PREVENT
EXHAUST FUMES FROM ENTERING THE VEHICLE!**



 **DANGER** 
**INSPECT FOR FUEL TANK, FUEL LINES, BRAKE LINES, HIGH
VOLTAGE BATTERIES AND ELECTRICAL LINES PRIOR TO
DRILLING TO AVOID DAMAGING CRITICAL VEHICLE SYSTEMS
OR INJURY TO INSTALLER DURING INSTALLATION PROCESS!**



 **CAUTION** 
**TO AVOID DAMAGING THE VEHICLE ALWAYS
USE DRILL STOPS WHEN DRILLING ANY IN-
STALLATION HOLES!**



- IMPORTANT WARRANTY REQUIREMENTS -

1. SUBSTITUTING ADRIAN STEEL SPECIFIED FASTENERS FOR ASSEMBLY AND/OR INSTALLATION WILL VOID YOUR PRODUCT WARRANTY.
2. ALL HOLES DRILLED INTO VEHICLE SHOULD HAVE THE RAW METAL EDGES SEALED WITH A SELF-ETCHING PRIMER TO RESIST CORROSION AND POTENTIAL FASTENER POINT FAILURE.
3. ALL FASTENERS USED IN THE INSTALLATION OF THIS PRODUCT SHOULD BE TIGHTENED TO THE TORQUE(S) SPECIFIED IN THESE INSTRUCTIONS.
4. THESE INSTRUCTIONS SHOULD BE KEPT WITH THE VEHICLE.

THE BASIC TOOLS NEEDED FOR MOST INSTALLATIONS



DRILL



DRILL BIT WITH
STOP



RATCHET, SOCKETS
AND/OR WRENCHES



SCREWDRIVERS



MEASURING TAPE

ADDITIONAL TOOLS MAY BE NEEDED FOR THIS INSTALLATION AND THEY WILL BE IDENTIFIED IN THE STEPS THAT FOLLOW.

BAG52105 - DROP DOWN ASSEMBLY BAG, MID ROOF

ITEM NO.	PART NUMBER	DESCRIPTION	QTY.
1	BAG0507-A	5" x 7" 3MIL AUTOBAG	1
2	FAS0248	Nut, Nylon Insert Lock, 5/16-18 SST	34
3	34927-0	Ball Stud, Damper	4
4	34924-0	Neoprene Bumper	4
5	FAS0552	Washer, Flat, 5/16, SST	23
6	FAS0830	Screw, Hex Hd, 5/16-18 X 1.25 SS	10
7	FAS0799	Screw, Hex Hd, 5/16-18x0.75 SS	8
8	FAS0179	Screw, Hex Hd, 5/16-18x2.00 STAINLESS STEEL	6
9	FAS0811	SCREW,CAP, 5/16-18X3.50 SS	2
10	26618-0	Silicone Sealant	1
11	34928-0	Clip, Suspa P/N P68-00019	4
12	05586-0	Butyl Tape, T224 -1/2"X 1' Roll	1
13	34921-0	CLAMP, CABLE, LOOP, 1.5" ID	1
14	34922-0	TOOL HOLDER	1
15	FAS0674	SCREW, BHCS 10-24 X .75 SS	2
16	FAS0554	NUT , NYLON LOCK, #10-24, SS	2

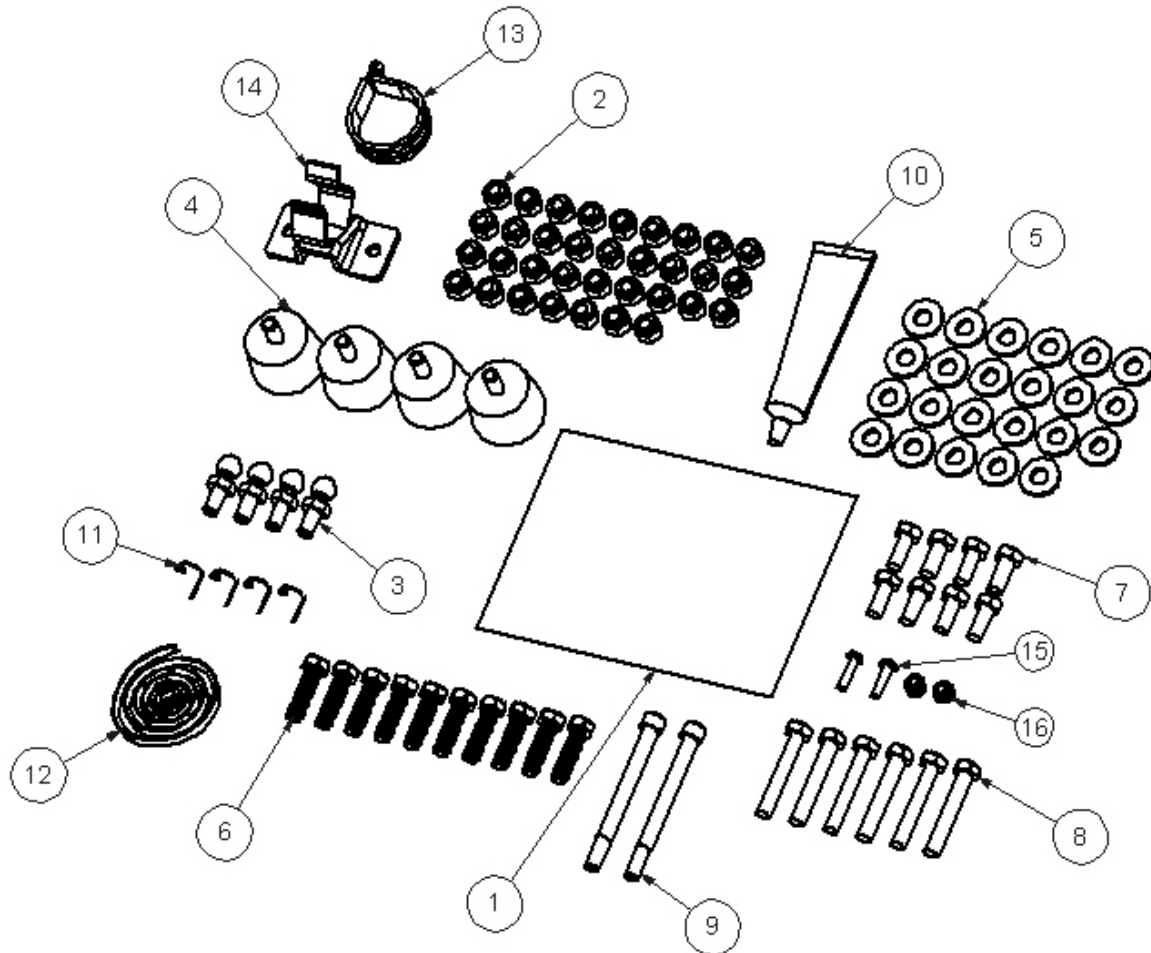

BAG51041—FINAL ASSEMBLY FASTENER BAG

ITEM NO.	PART NUMBER	DESCRIPTION	QTY.
1	BAG0507-A	5" x 7" 3MIL AUTOBAG	1
2	FAS0246	Washer, Flat, 3/8, HRD, ZN	6
3	FAS0799	Screw, Hex Hd, 5/16-18x0.75 SS	4
4	FAS0110	Nut,Hex Nylk 3/8-16 SS W	4
5	FAS0572	Screw, Button Hd Hex Soc, 3/8-16x1.00 NI-ZN	2
6	FAS0588	Washer, Lock, Split, 5/16, SS	4
7	FAS0286	SCREW, HHCS, 3/8-16x4, SS	2
8	FAS0287	COTTER PIN, 1/16DIA X 1"LG, SS	2

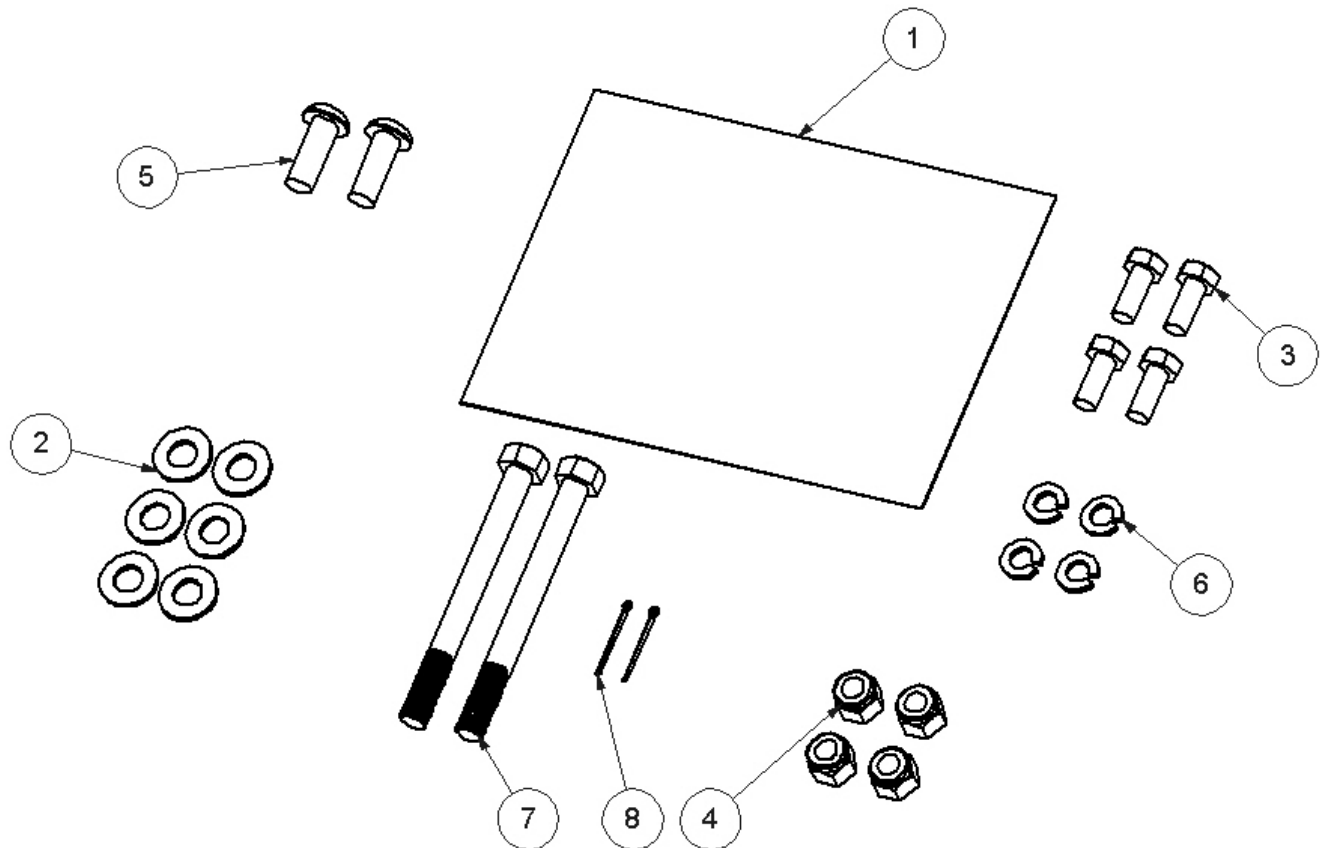

STEP #1A : ASSEMBLE CURB SIDE REAR CROSS BOW

REAR OF THE VAN

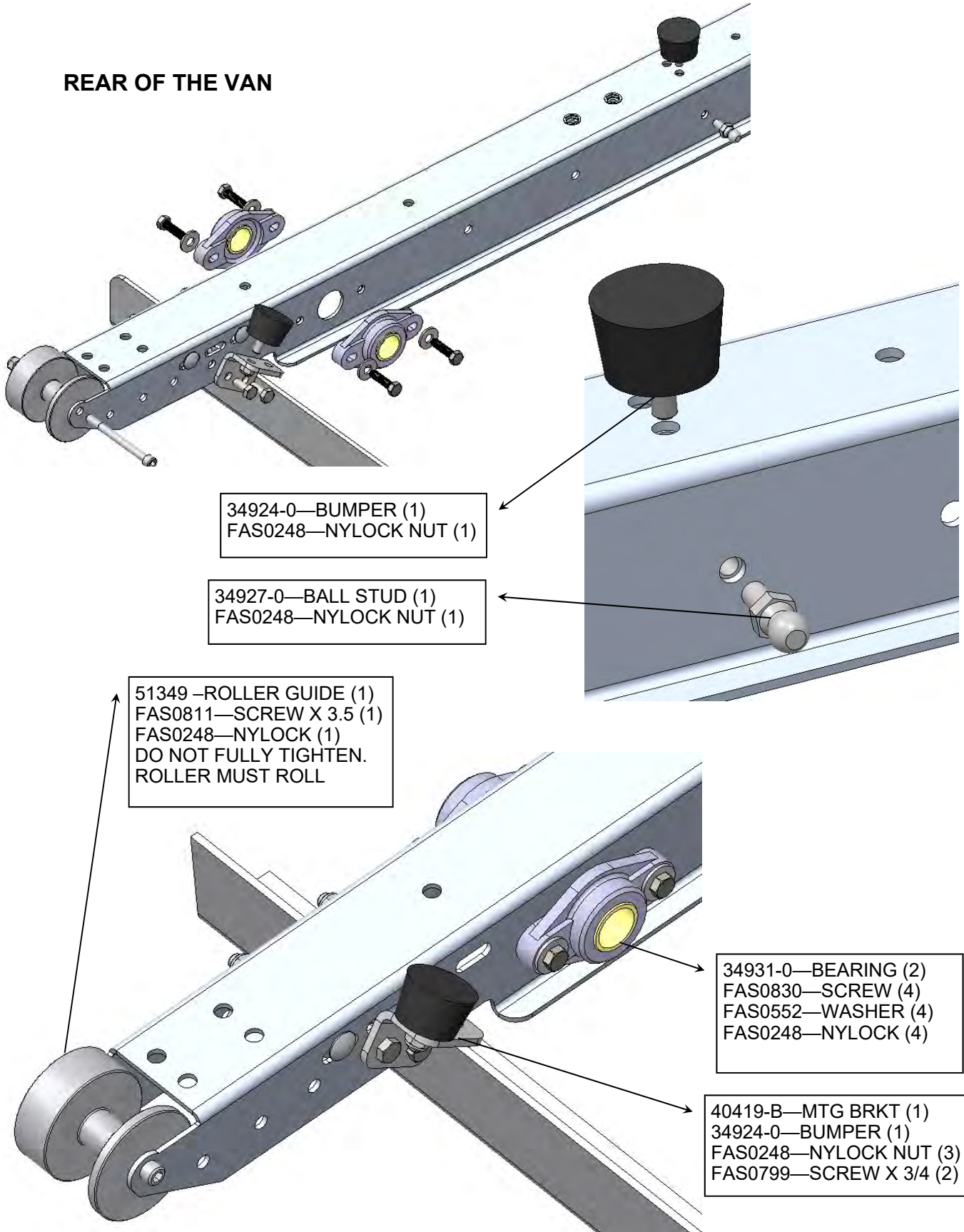

34924-0—BUMPER (1)
FAS0248—NYLOCK NUT (1)

34927-0—BALL STUD (1)
FAS0248—NYLOCK NUT (1)

51349—ROLLER GUIDE (1)
FAS0811—SCREW X 3.5 (1)
FAS0248—NYLOCK (1)
DO NOT FULLY TIGHTEN.
ROLLER MUST ROLL

34931-0—BEARING (2)
FAS0830—SCREW (4)
FAS0552—WASHER (4)
FAS0248—NYLOCK (4)

40419-B—MTG BRKT (1)
34924-0—BUMPER (1)
FAS0248—NYLOCK NUT (3)
FAS0799—SCREW X 3/4 (2)

STEP #2A : ASSEMBLE CURB SIDE FRONT CROSS BOW. DO NOT ATTACH TO THE RAIL YET.

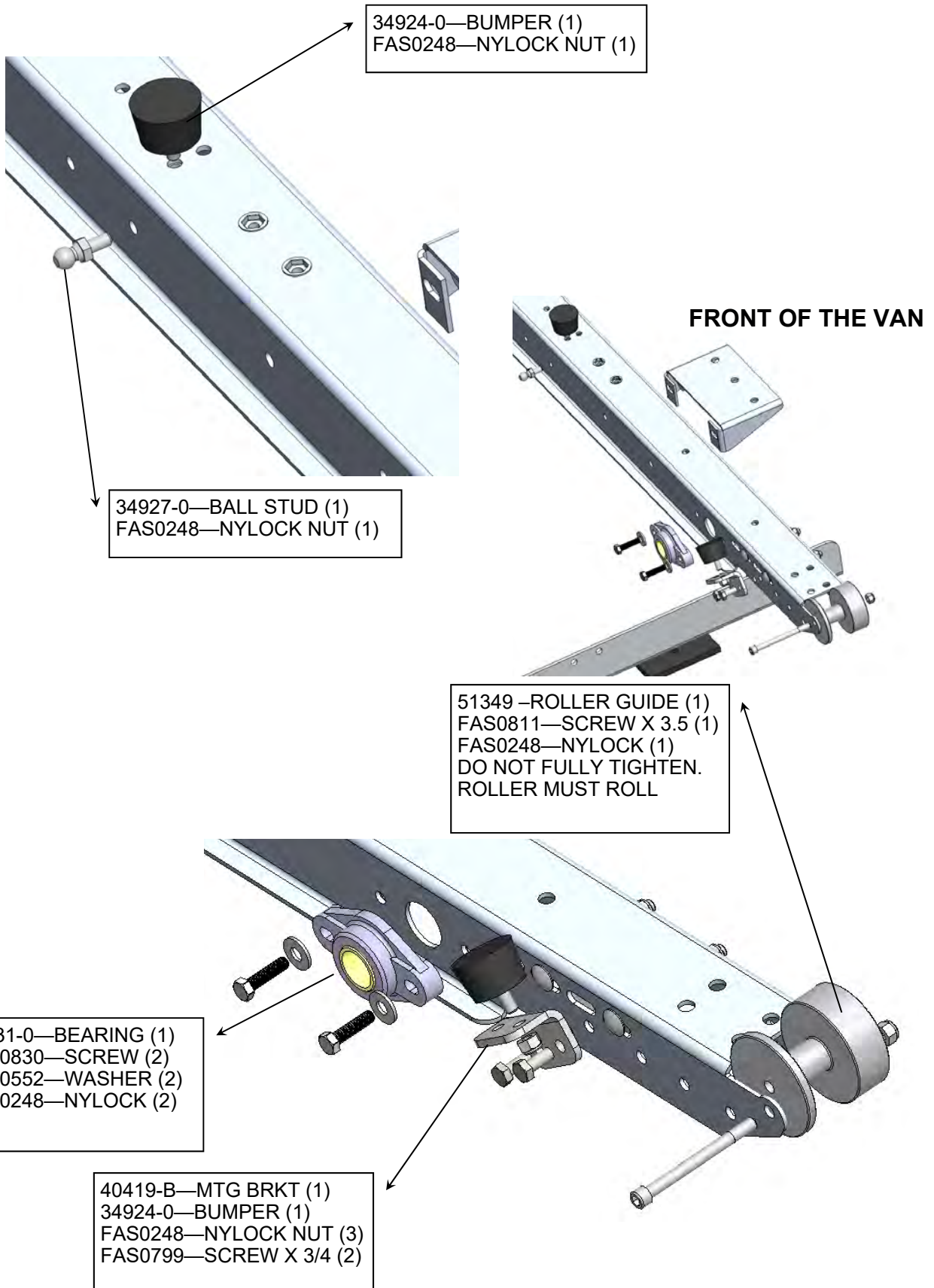



STEP #2B : ASSEMBLE CURB SIDE FRONT CROSS BOW. DO NOT ATTACH TO THE RAIL YET.

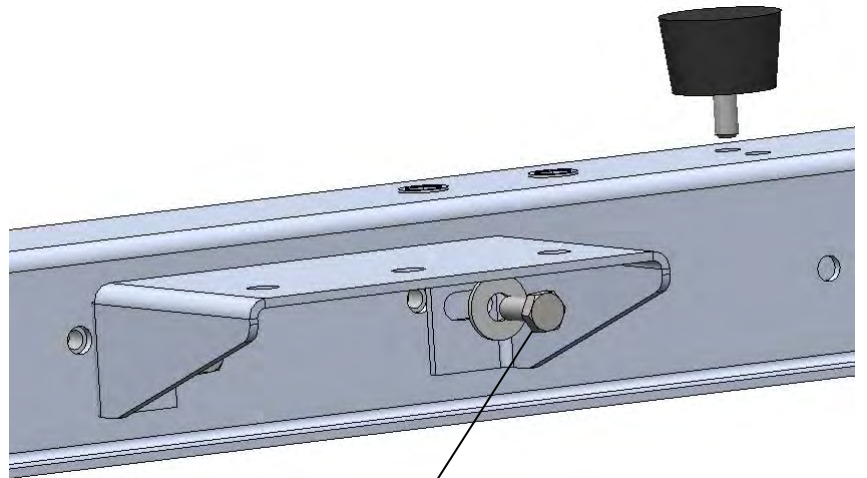
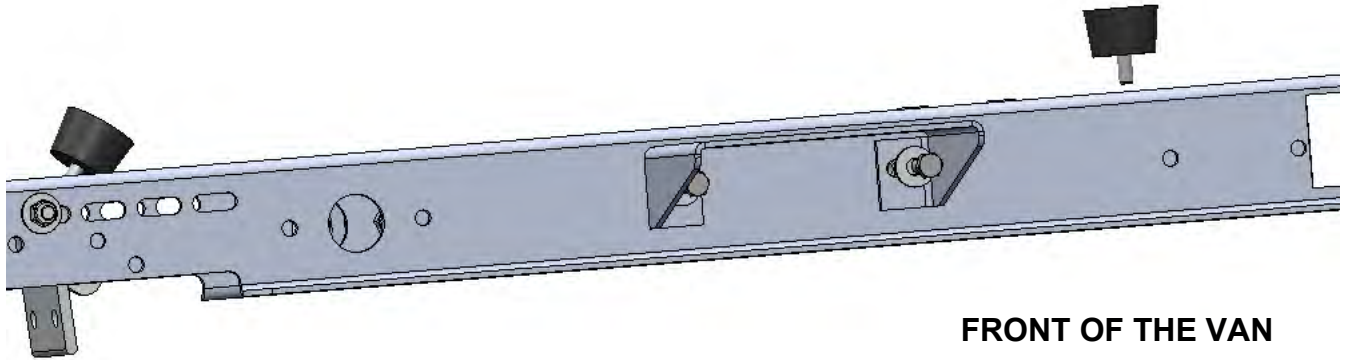

- 50828—MTG PLATE (1)
- FAS0799 -SCREW X 3/4 (2)
- FAS0552—WASHER (2)
- FAS0248—NYLOCK (2)

STEP #3A : ASSEMBLE CURB SIDE PIVOT DRIVE TO THE CROSS BOWS

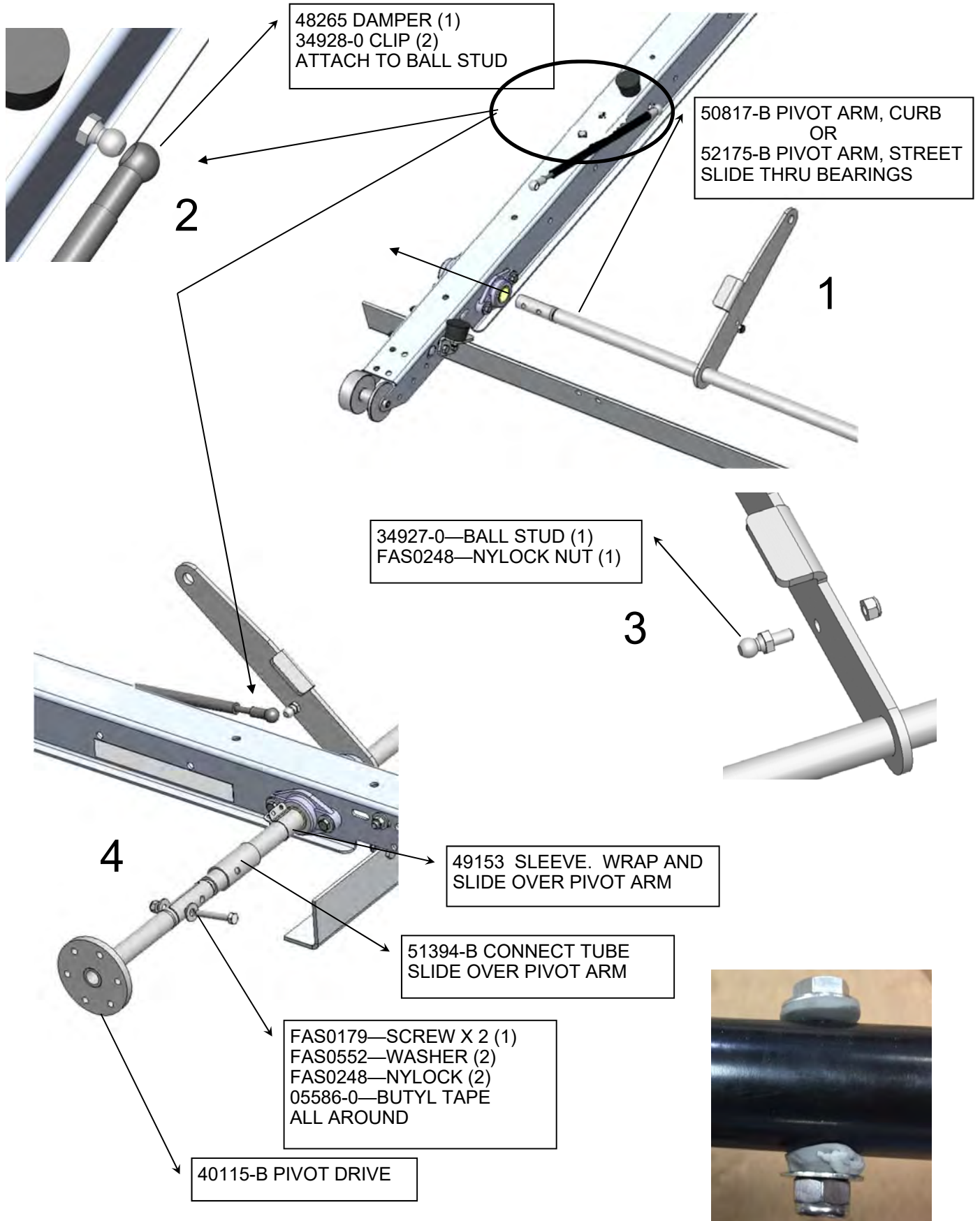

STEP #3B : ASSEMBLE CURB SIDE PIVOT DRIVE TO THE CROSS BOWS

SLIDE TUBE DOWN
FAS0179—SCREW X 2 (1)
FAS0552—WASHER (2)
FAS0248—NYLOCK (2)
05586-0—BUTYL TAPE
ALL AROUND

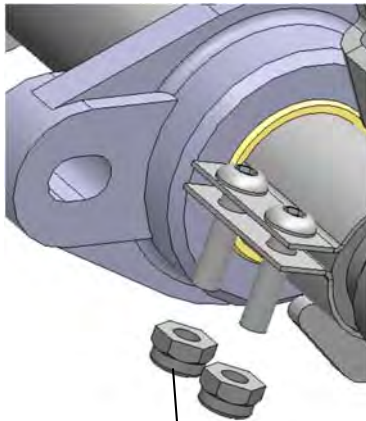
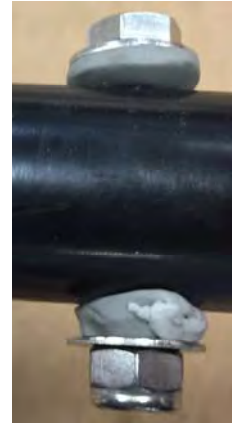
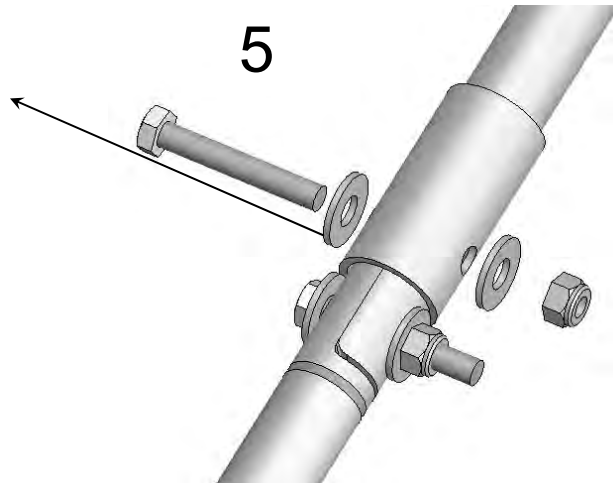

SCREWS MUST BE ON THIS SIDE !!
FAS0674—SCREW X 3/4 (2)
FAS0554—NUT (2)

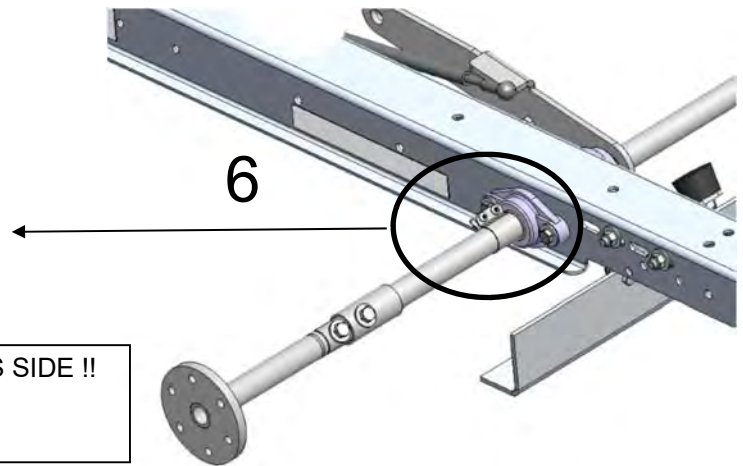

CHECK ORIENTATION
FAS0830—SCREW (3)
FAS0248—NYLOCK (3)

34972-0—HANDLE JUNCTION

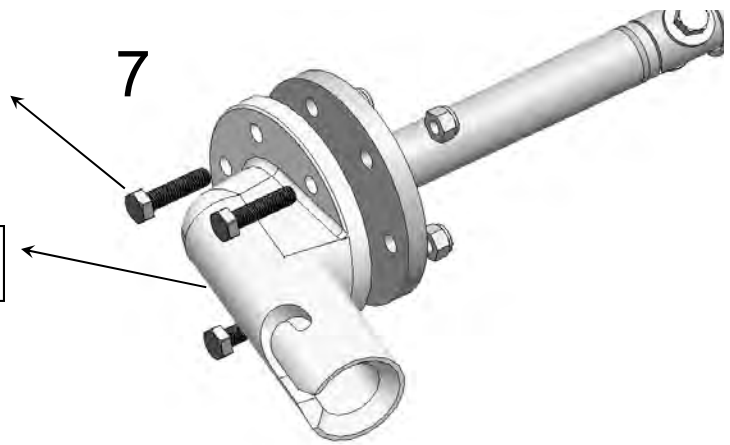

STREET SIDE

CURB SIDE



STEP #4A : ASSEMBLE CURB SIDE PIVOT DRIVE AT REAR OF VEHICLE.

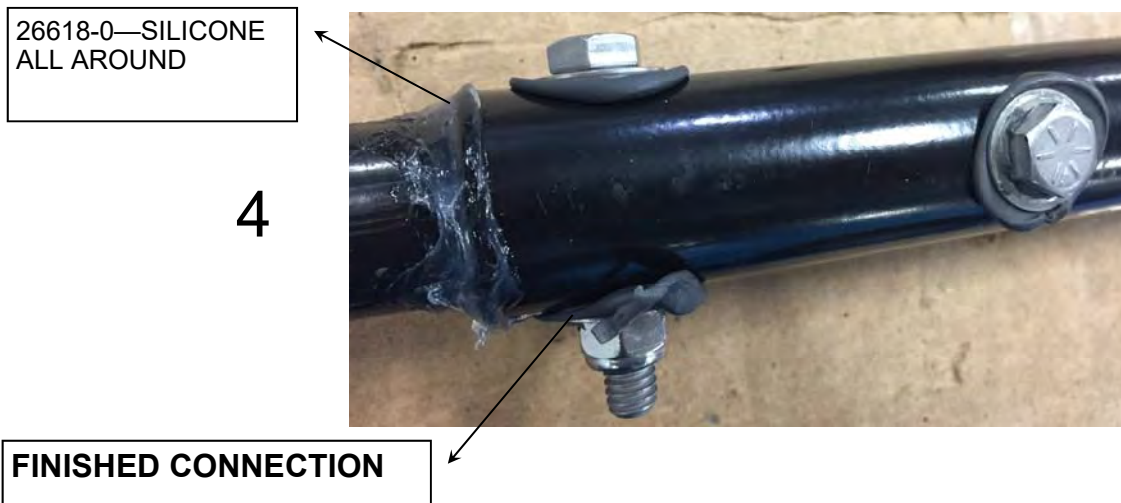
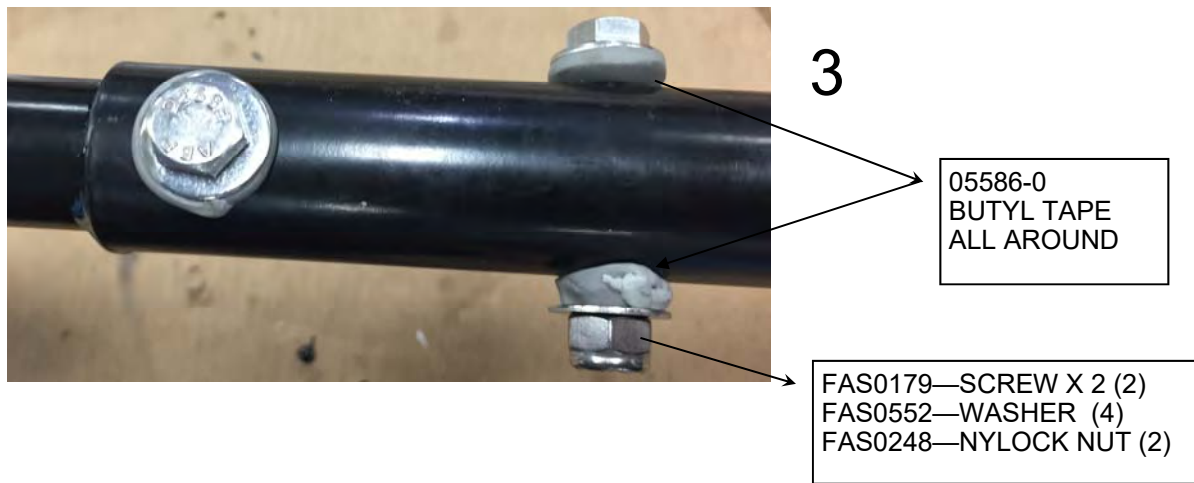
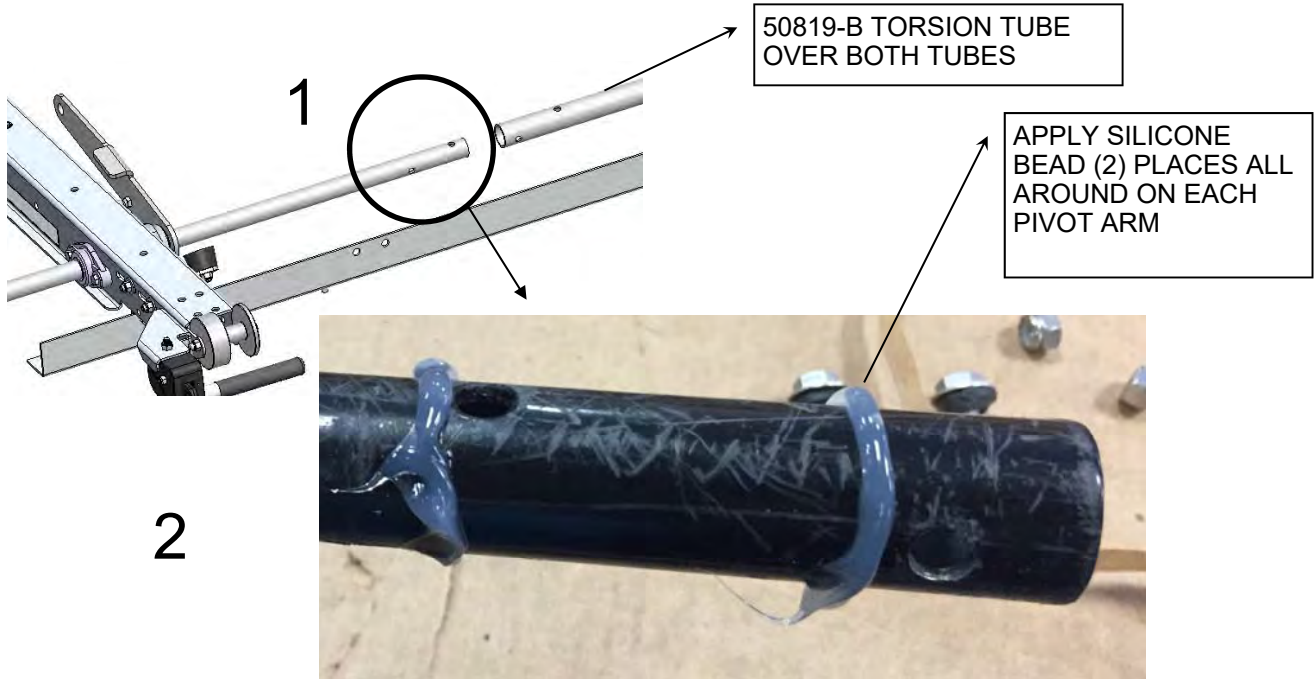

STEP #4B : ASSEMBLE CURB SIDE PIVOT DRIVE AT FRONT OF VEHICLE

APPLY SILICONE BEAD (2) PLACES ALL AROUND ON EACH PIVOT ARM

5

50817-B—PIVOT ARM, CS



6



7

05586-0 BUTYL TAPE ALL AROUND

FAS0179—SCREW X 2 (4)
FAS0552—WASHER (8)
FAS0248—NYLOCK NUT (4)

26618-0—SIL1CONE ALL AROUND

8



FINISHED CONNECTION

STEP #4C : ASSEMBLE CURB SIDE PIVOT DRIVE TO THE CROSS BOWS

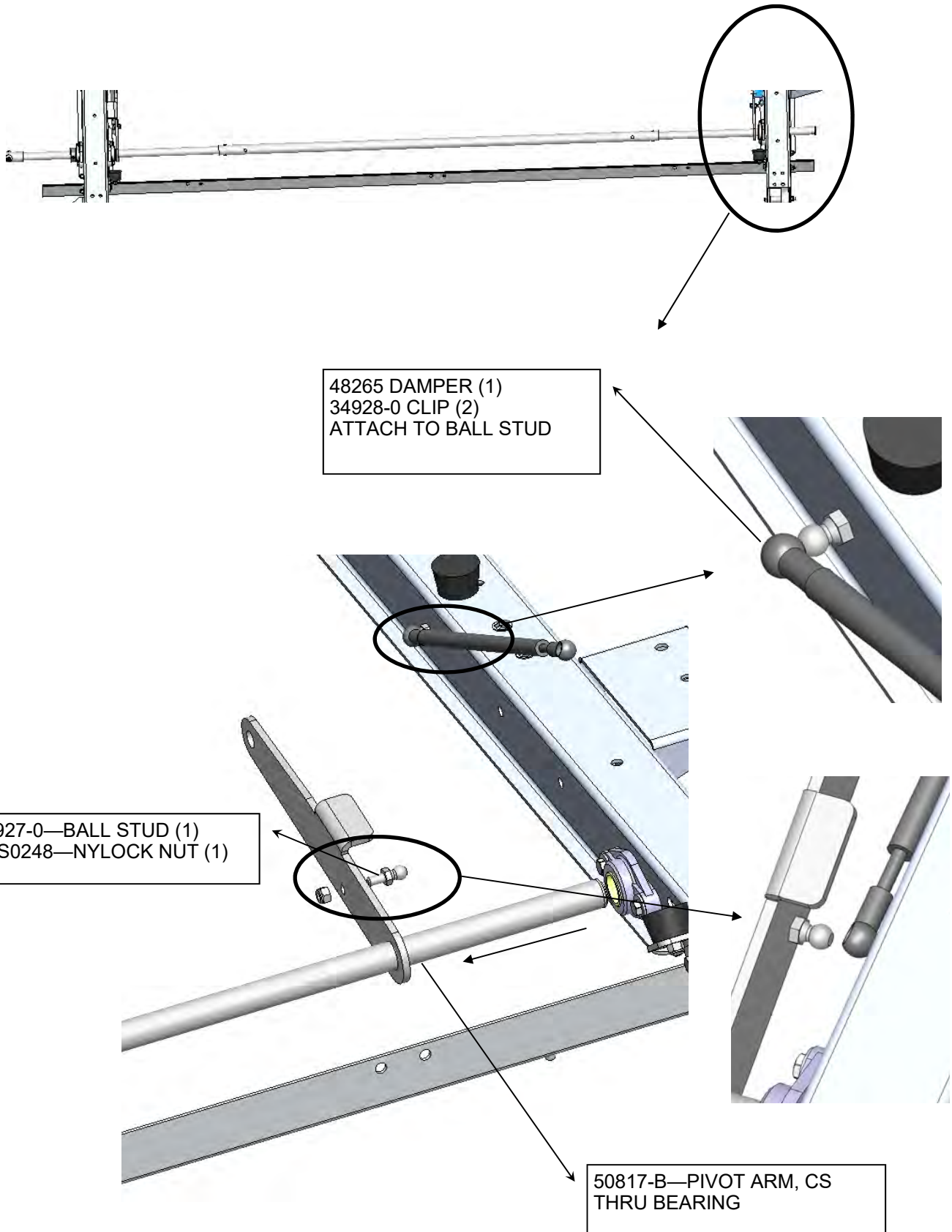

STEP #5A : CHECK WHAT YOU ARE BUILDING

- CONTINUE TO STEP #6 FOR A CURB SIDE ONLY INSTALL
- REPEAT STEPS 1 THRU 4 FOR THE STREET SIDE PIVOT DRIVE USING 52175-B PIVOT ARM, STREET IN PLACE OF 50817-B PIVOT ARM, CURB.

THIS IS THE SHIP THRU FINAL SINGLE DROP DOWN

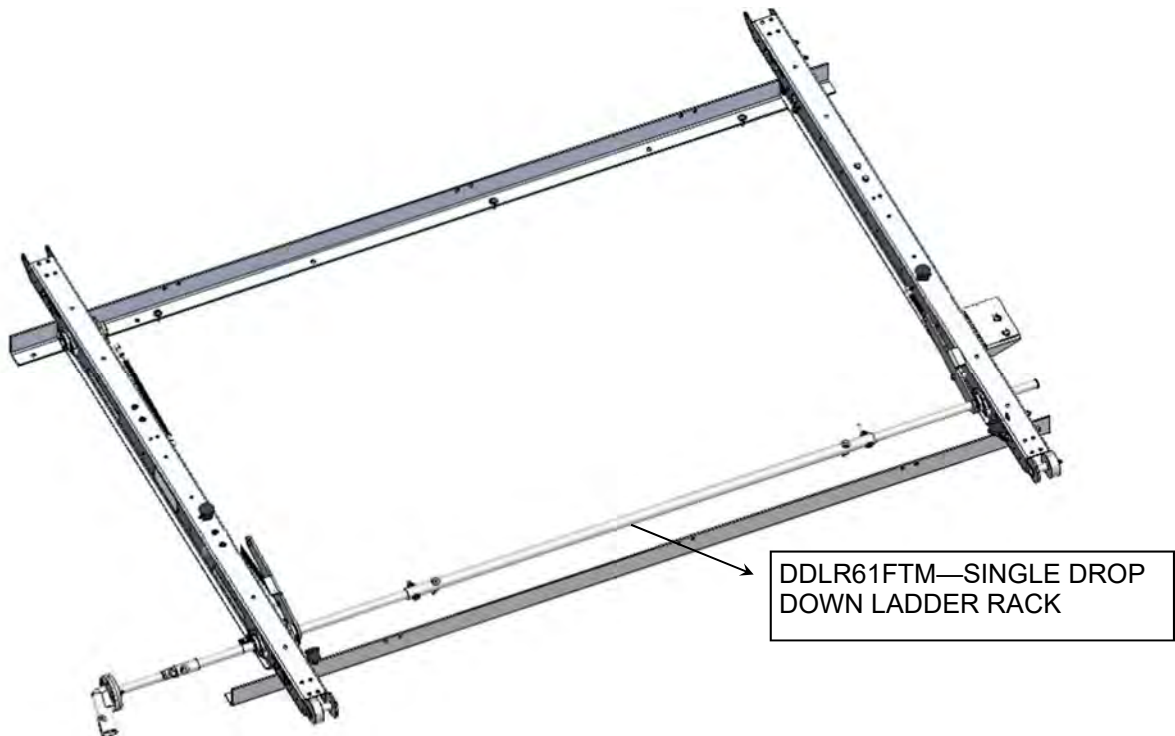

THIS IS THE SHIP THRU FINAL DOUBLE DROP DOWN

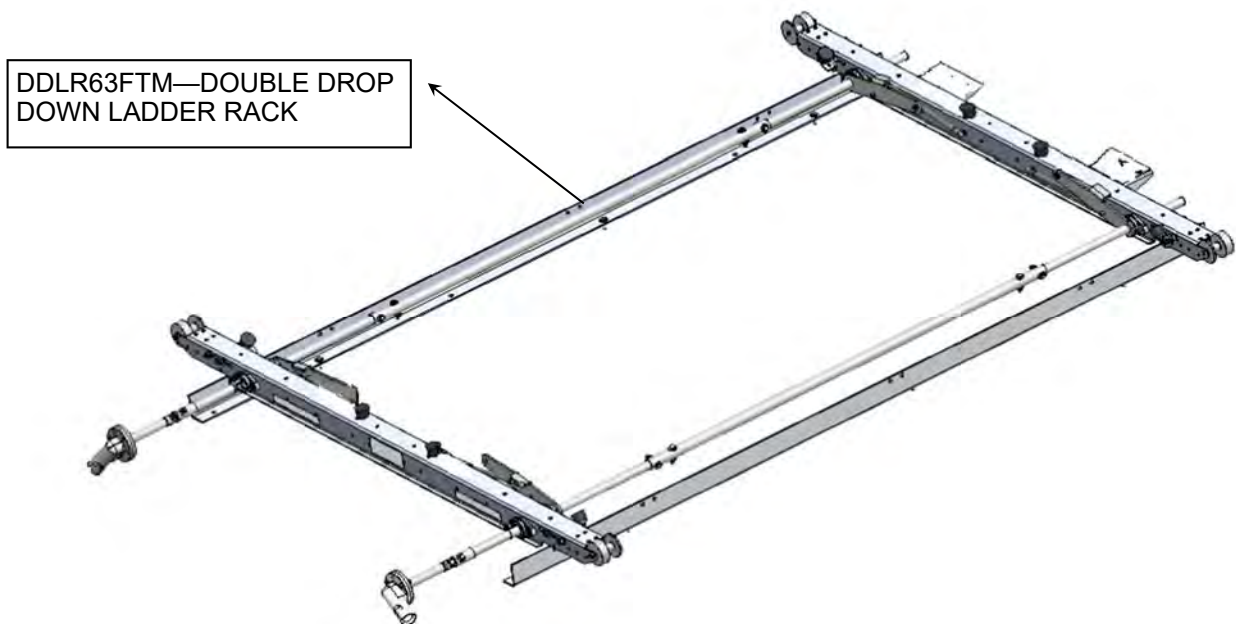

STEP #5B : THIS IS THE SHIPTHRU FINAL—SHOWING SINGLE AND DOUBLE AS YOU WOULD RECEIVE FOR FINAL DEAL ASSEMBLY.

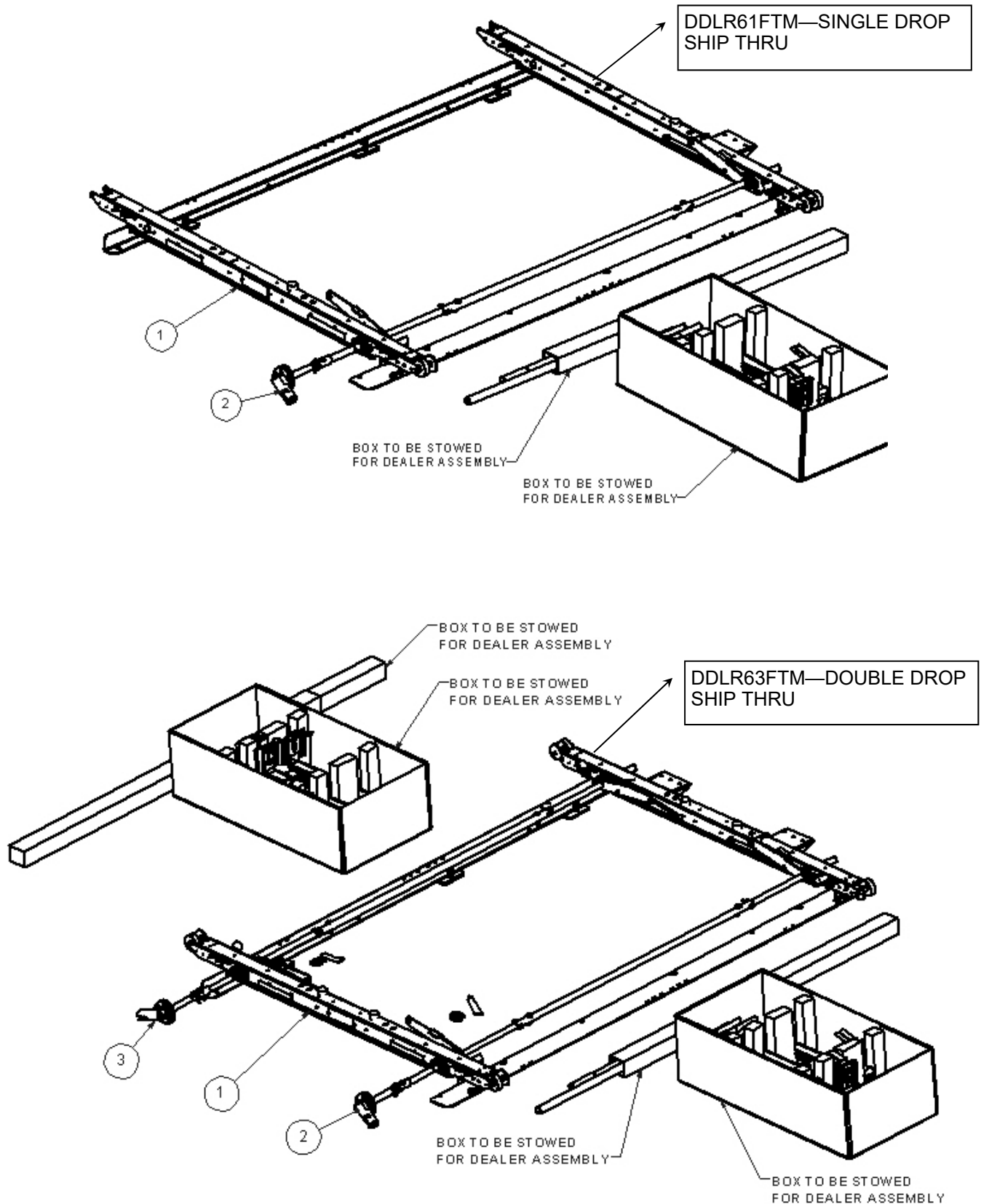

STEP #6 - FINAL ASSEMBLY, SHOWING THE CURB AND STREET SIDE DROP DOWN COMPONENTS

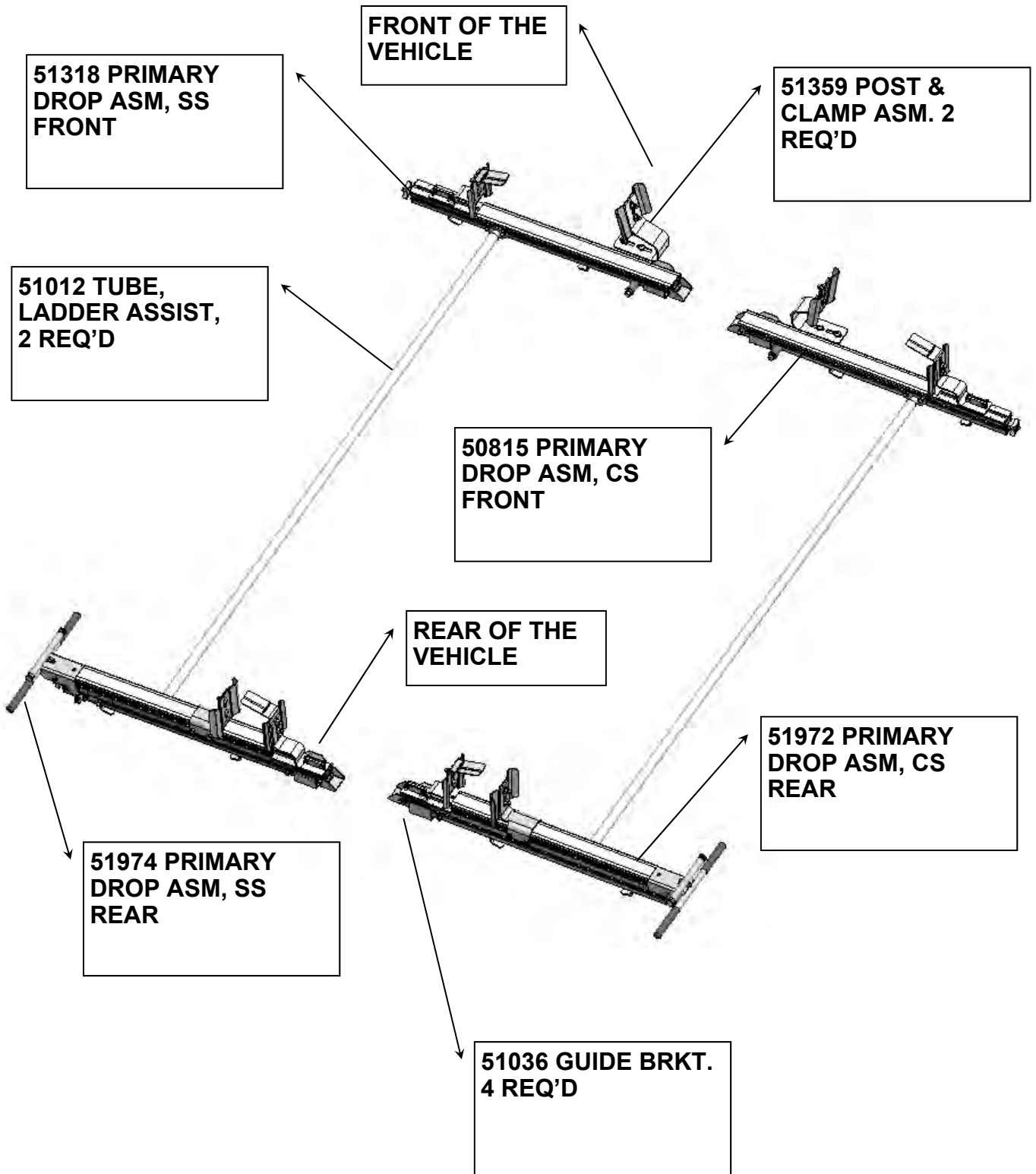

STEP #7- ASSEMBLE BRACKETS TO THE FRONT AND REAR CROSS BOWS

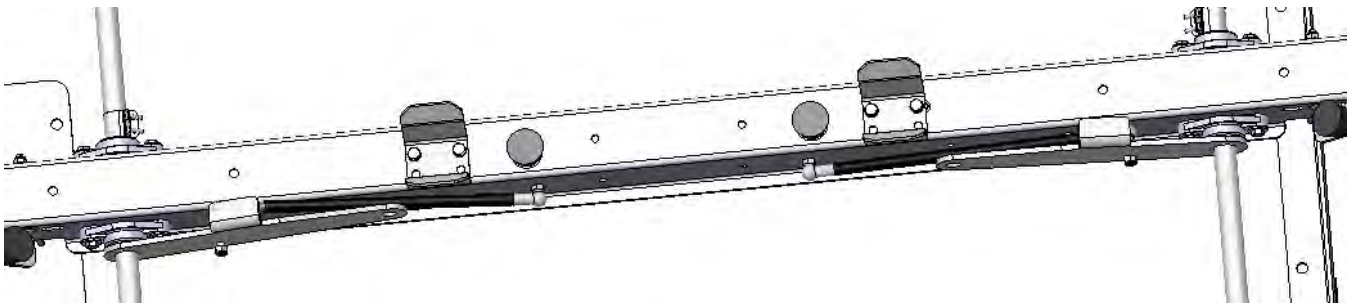

STEP 7 : COMPLETED VIEW OF THE REAR CROSS BOW

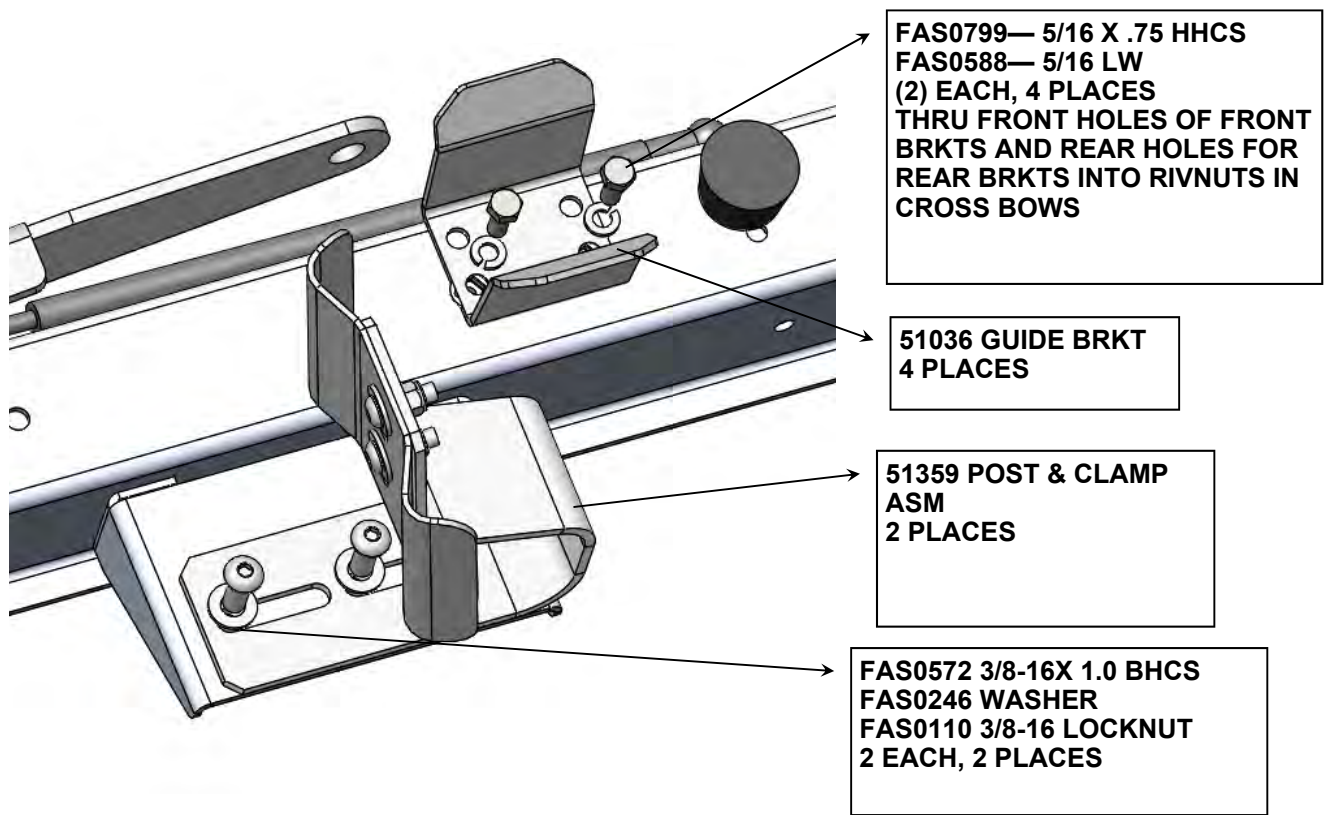

STEP 7 : COMPLETED VIEW OF THE FRONT CROSS BOW

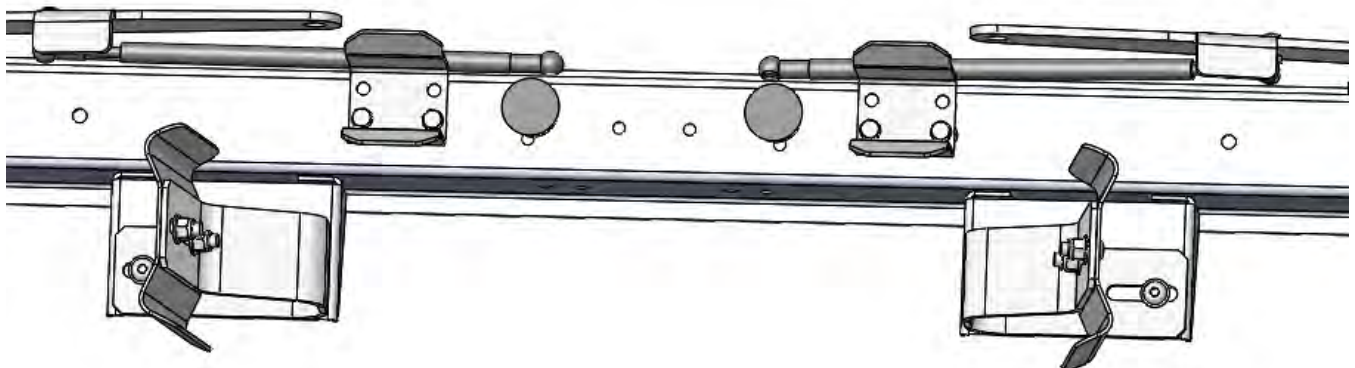

STEP 8 : ASSEMBLE REAR CURB SIDE PRIMARY DROP TO CROSS BOW

**SET 51972 PRIMARY DROP ASM, REAR CS IN PLACE ON REAR CROSS BOW.
USE GUIDE ROLLER**

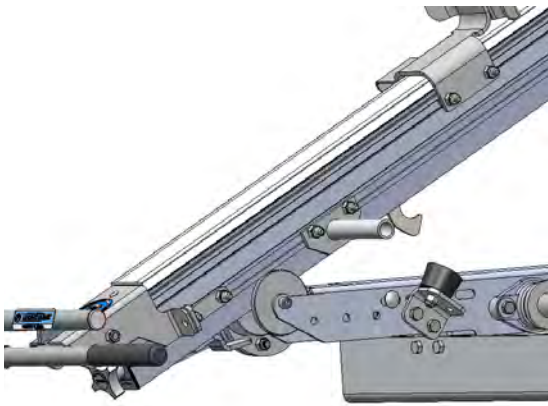

**51972 PRIMARY DROP
ASM CS REAR**

**51972 PRIMARY DROP
ASM, CS REAR**

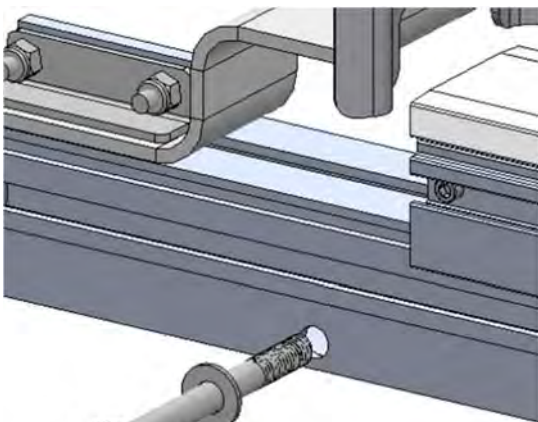
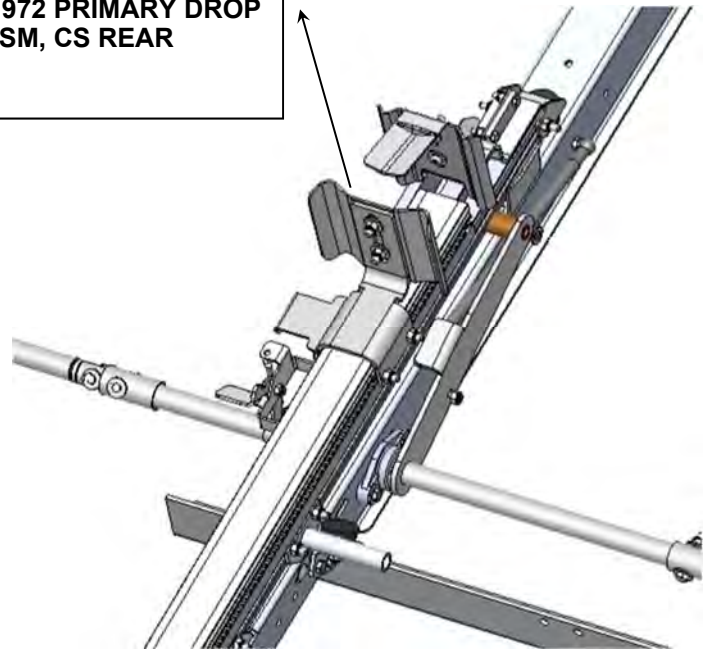

**FAS02826 3/8-16 X 4" HHCS
FAS0246 WASHER**

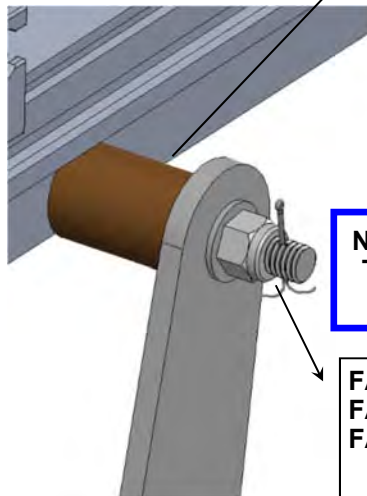

**51034 BRONZE
BUSHING**

**NOTE: TORQUE NYLOCK NUT
TO 20FT.LBS, THEN INSERT/
SECURE THE COTTER PIN.**

**FAS0246 WASHER
FAS0110 3/8-16 NYLOCK NUT
FAS0287—COTTER PIN**

**NOTE: AFTER THE COTTER
PIN IS INSERTED THROUGH
THE BOLT, SPREAD THE PIN
SO IT CAN NOT BE REMOVED.**

STEP 9: ASSEMBLE FRONT SIDE PRIMARY DROP TO RACK

SET 50815 PRIMARY DROP ASM, FRONT CS IN PLACE ON FRONT CROSS BOW. USE GUIDE ROLLER AFTER LADDER ASSIST TUBE IS ON BOTH STUB SHAFTS

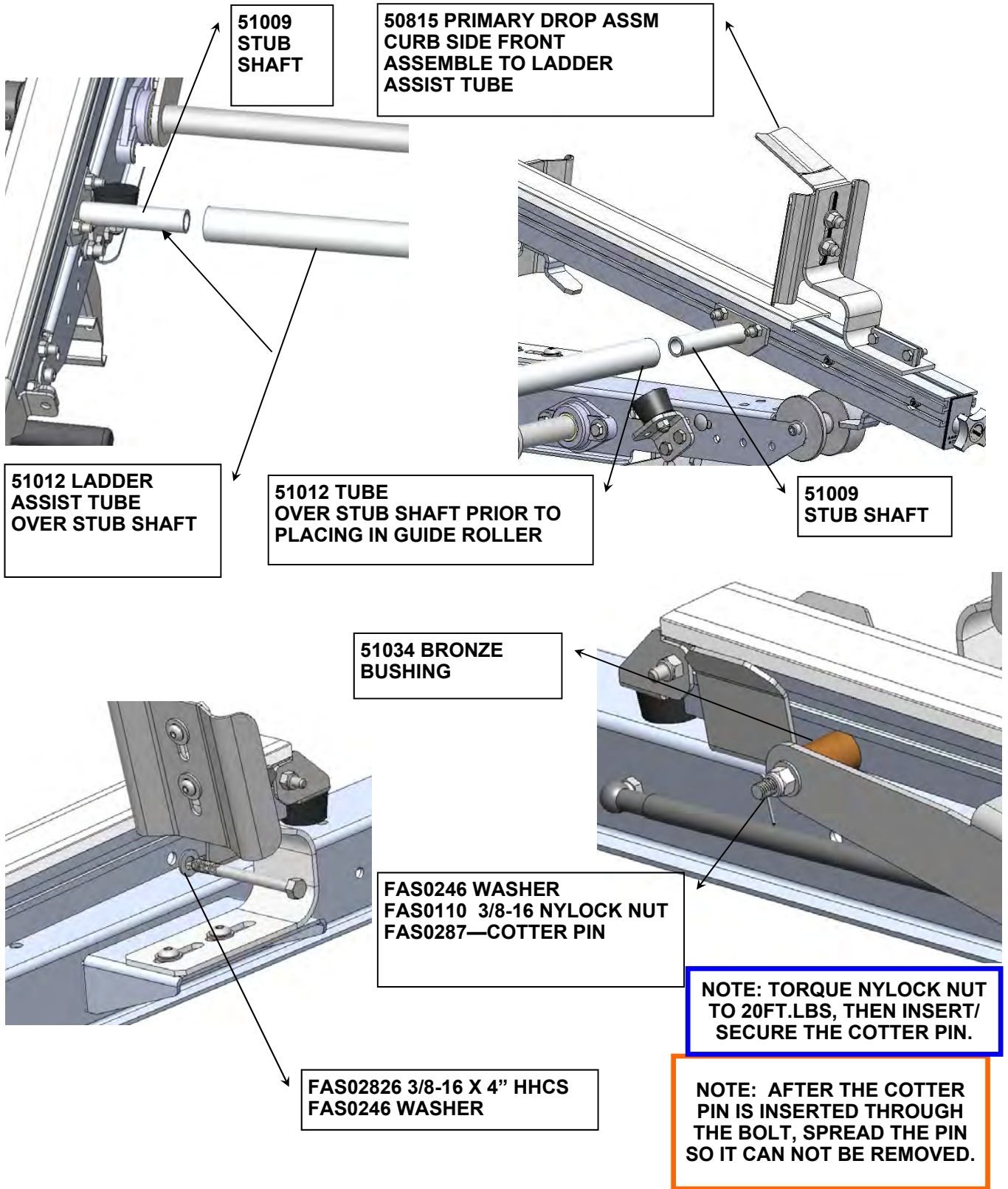

STEP #10 : ADJUST THE HIGH WIND LATCH TO YOUR VEHICLE

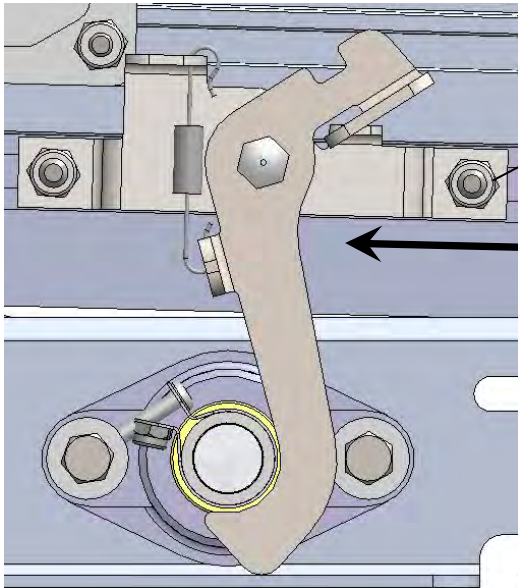

LOOSEN HEX NUTS WITH 1/2" WRENCH. ADJUST TO POSITION SHOWN AND TEST. ADJUST UNTIL LATCH IS WORKING PROPERLY AT NUMBER 5

1

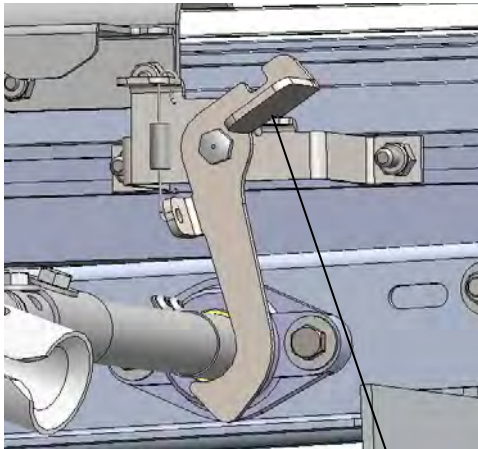

2

PUSH TO OPEN LATCH

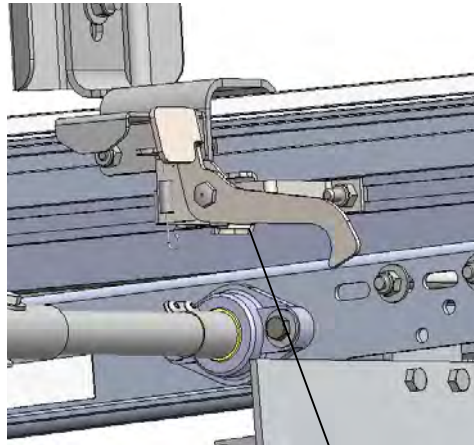

3

OPENED LATCH

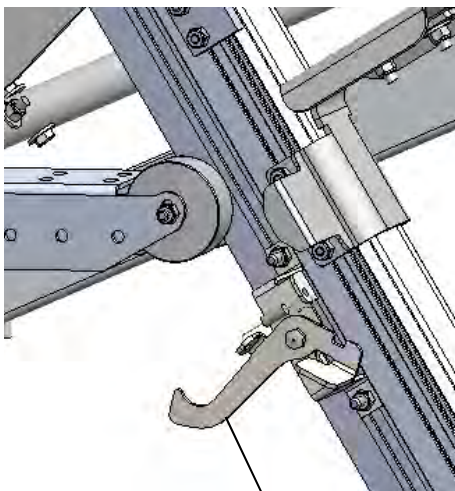

4

PIVOT DROP DOWN CLOSE LATCH

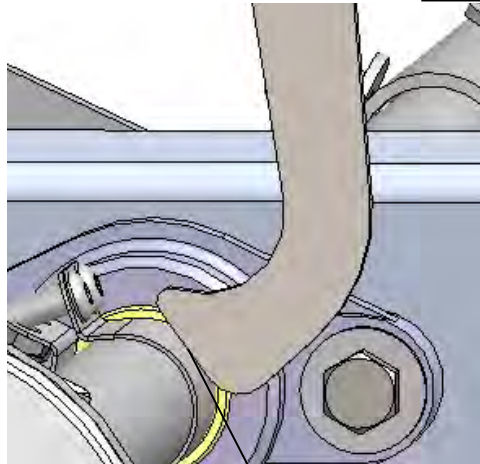

5

LATCH NEEDS TO HIT LEADING EDGE OF LATCH WHEN CLOSING



STEP #11 : FOR A DOUBLE DROP DOWN, INSTALL STREET SIDE USING STEPS #7, #8, #9 & #10 AS YOUR GUIDE.

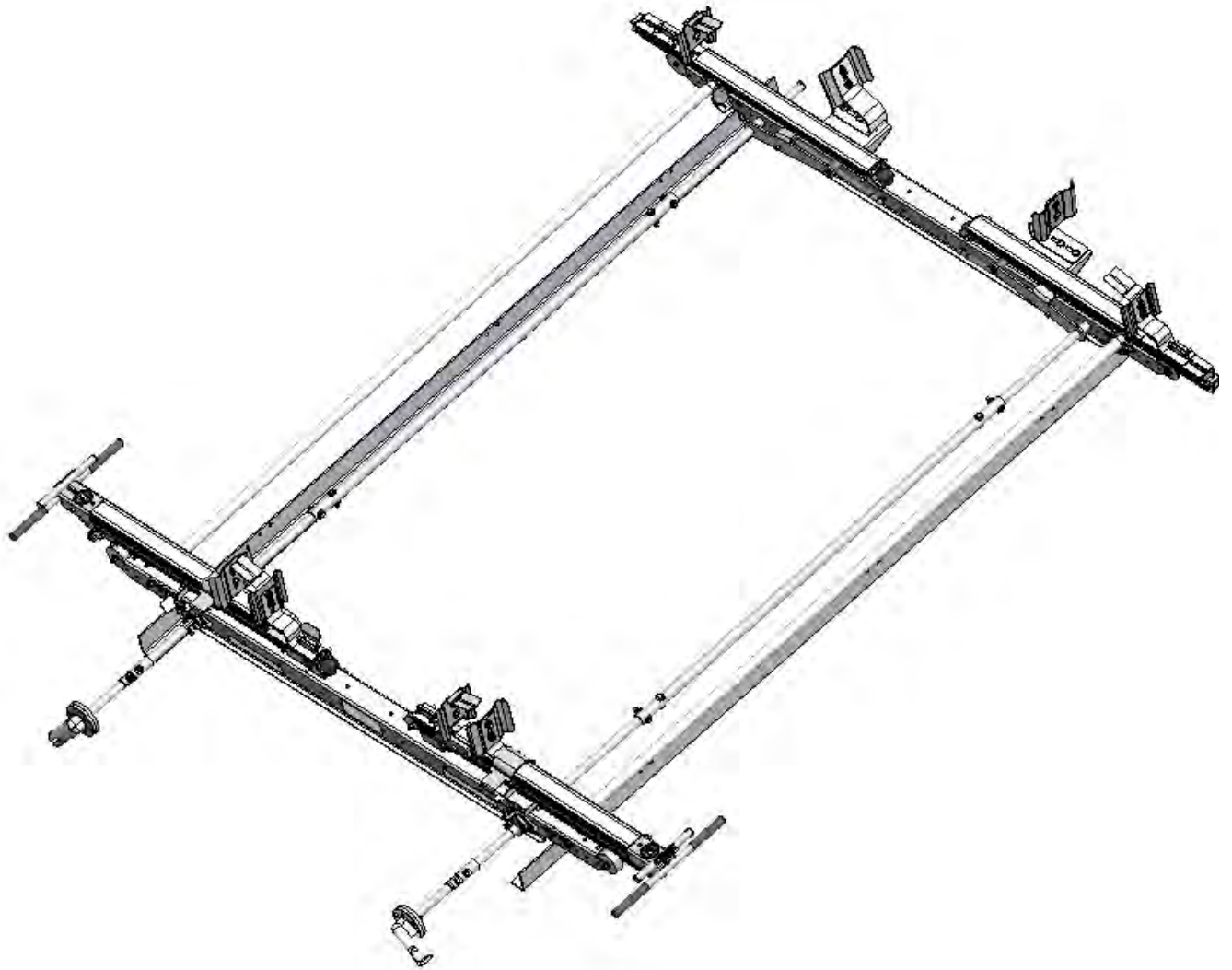

**DOUBLE CHECK ALL FASTENERS LOCATIONS TO BE SURE THAT ALL FASTENERS ARE TIGHTENED TO SPECIFICATIONS.
YOUR INSTALLATION IS NOW COMPLETE!
STOW THIS COPY IN THE VEHICLE FOR FUTURE REFERENCES!**



STEP #12 : USING THE HANDLE

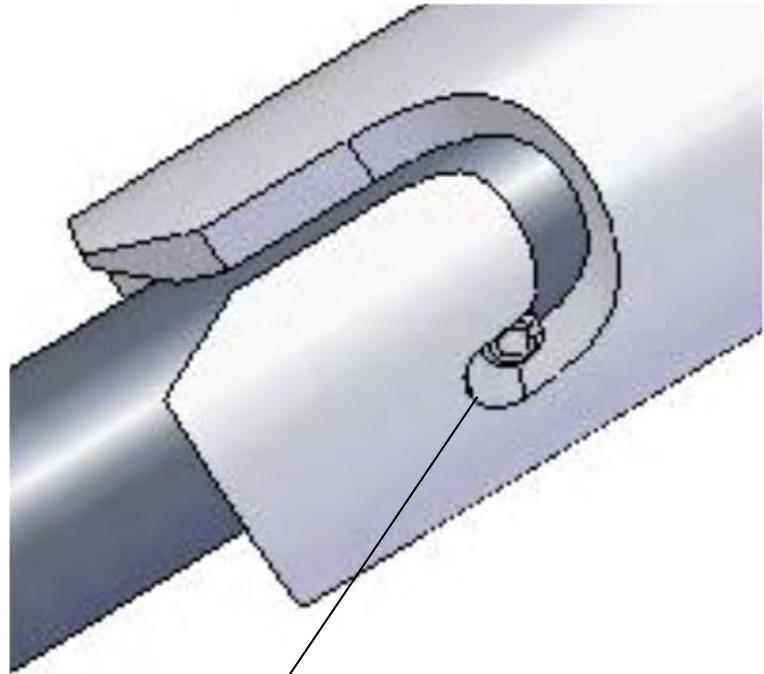
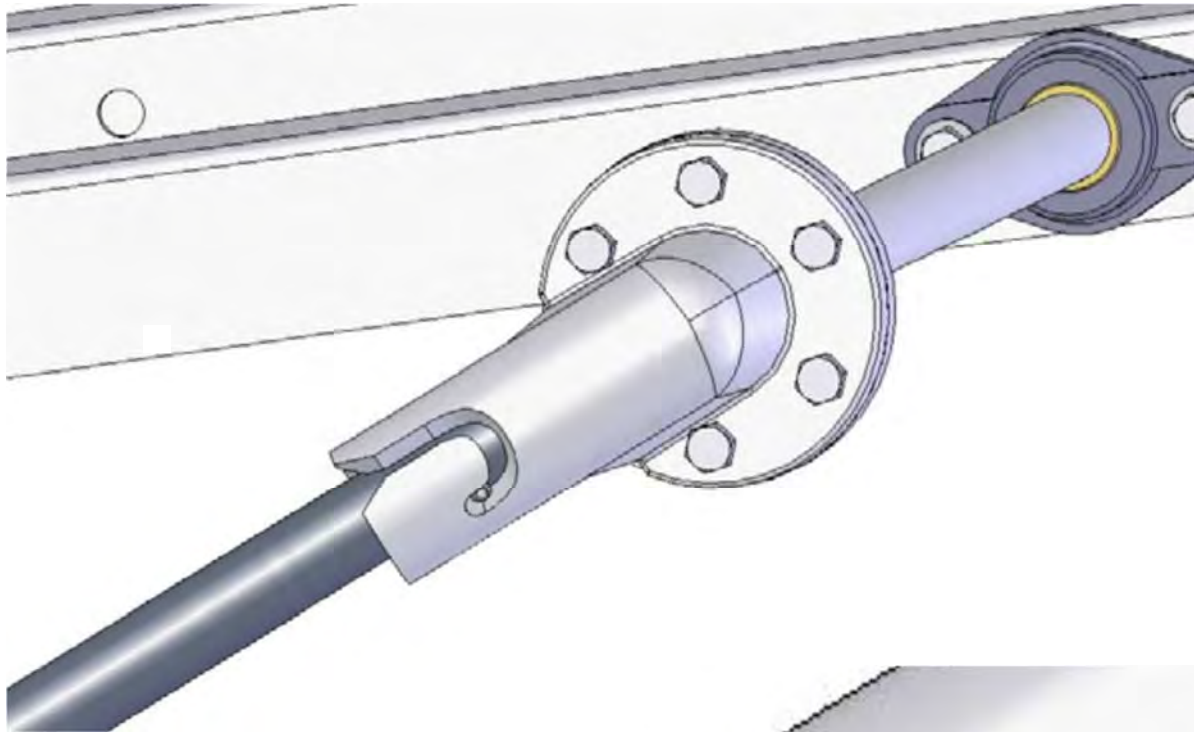

TO SECURE HANDLE INTO CASTING
ALIGN PIN WITH BOTTOM OF SLOT
IN CASTING, PUSH IN AND TWIST.

THEN PULL DOWN SO THE PIN IS IN
THE POSITION SHOWN.



STEP #13 : OPTIONAL, STOW THE PIVOT HANDLE

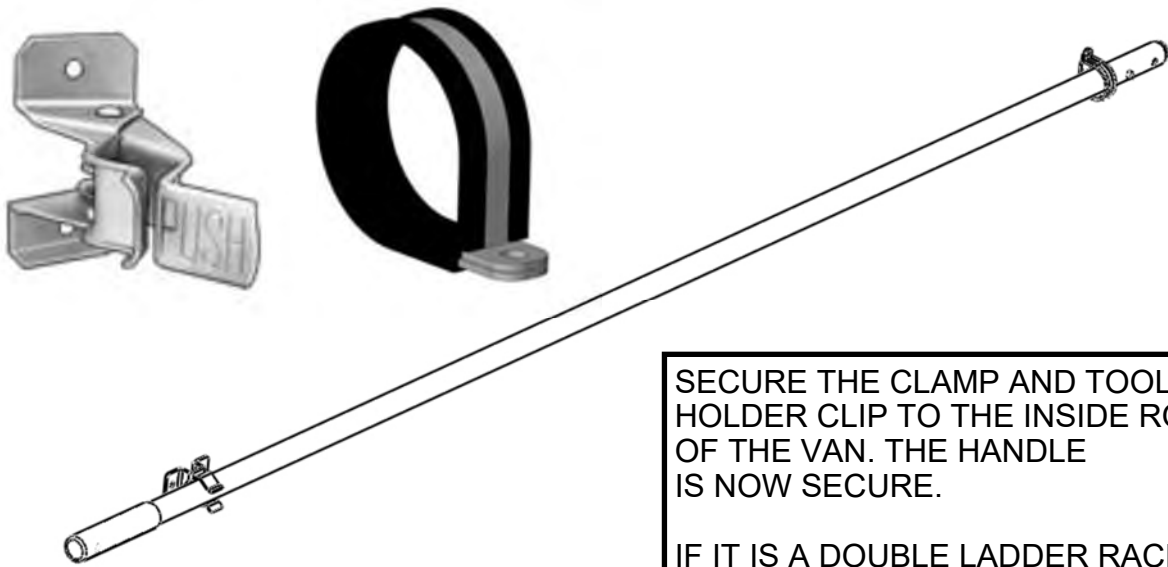

SECURE THE CLAMP AND TOOL HOLDER CLIP TO THE INSIDE ROOF OF THE VAN. THE HANDLE IS NOW SECURE.

IF IT IS A DOUBLE LADDER RACK, INSTALL A POLE ON EACH SIDE AS SHOWN.





STEP #14: YOUR DOUBLE DROP DOWN INSTALLATION IS NOW COMPLETE



**DOUBLE CHECK ALL FASTENER LOCATIONS TO BE SURE THAT ALL
FASTENERS ARE TIGHTENED TO SPECIFICATIONS.
YOUR INSTALLATION IS NOW COMPLETE!
STOW THIS COPY IN THE VEHICLE FOR FUTURE REFERENCES!**

**REAR CLAMP PAD MOVES TOWARDS CURB TO
TIGHTEN LADDER TO RACK**

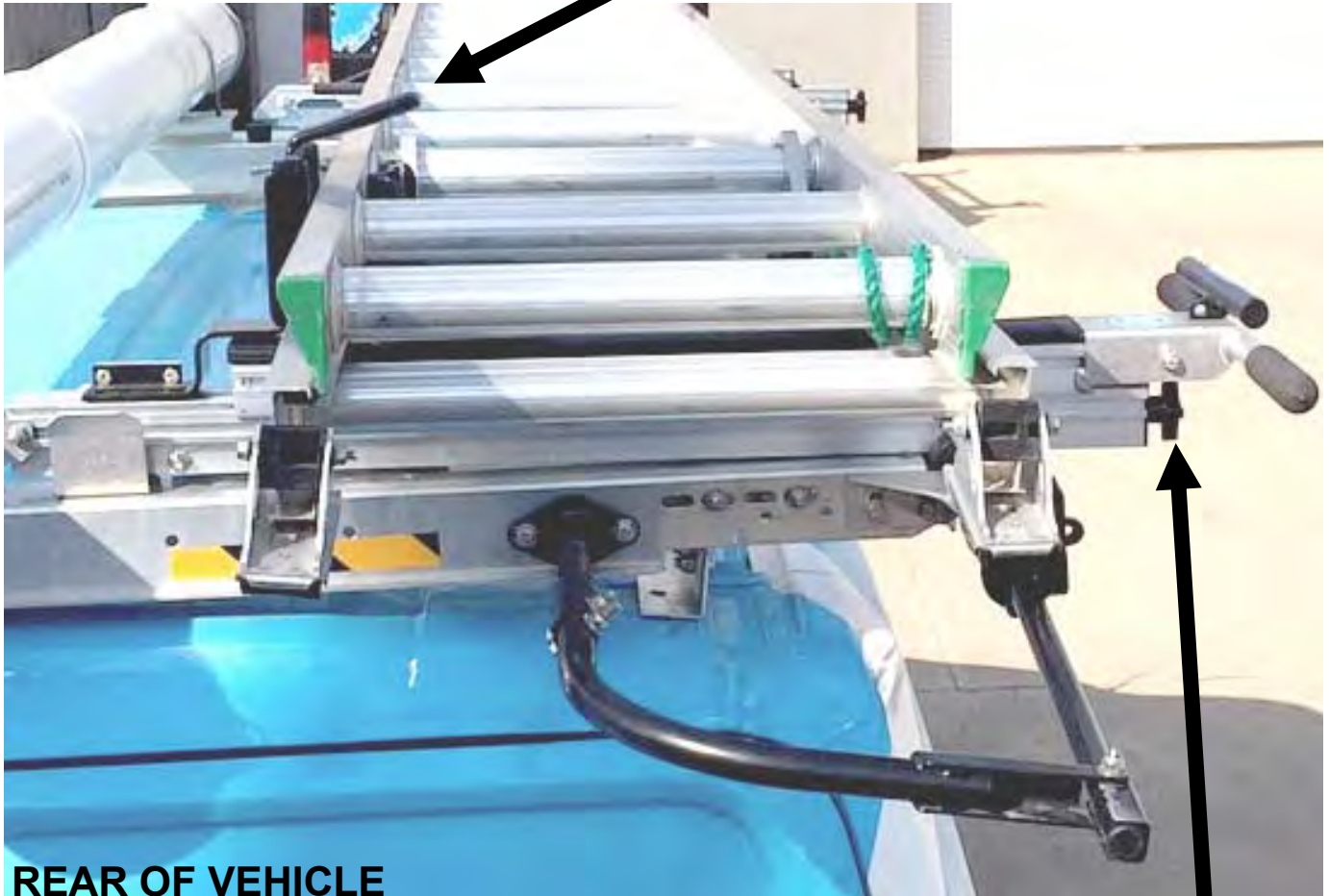

REAR OF VEHICLE



**TURN KNOB TO ADJUST TO
YOUR LADDER.**

**DO NOT OVER TIGHTEN!
CLAMP PAD SHOULD JUST
TOUCH THE LADDER.**

Proper Clamp Pad Locations

Below is the proper way to clamp the ladder to the vehicle (highlighted in green)

How to inspect for this: Properly placed clamp pads should be in close proximity to each other to allow the clamp pads to securely retain the ladder from side to side motion and front to back motion.

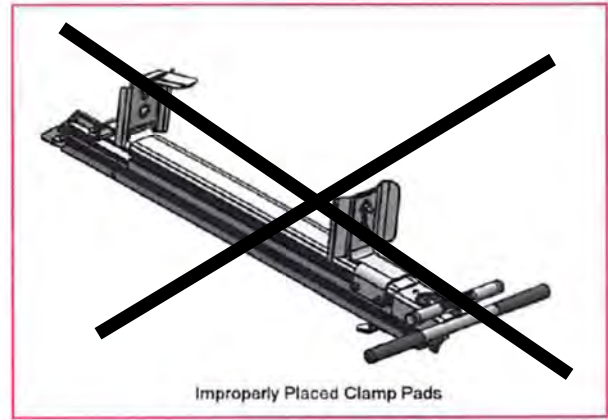
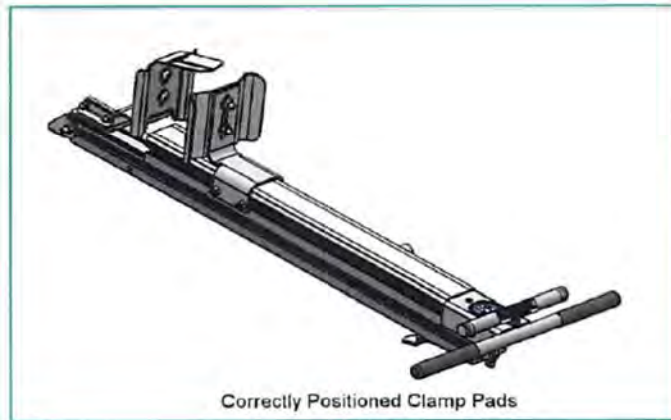

Above is the wrong way to clamp the ladder to the vehicle

**FRONT CLAMP PAD MOVES TOWARDS STREET
TO TIGHTEN LADDER TO RACK**



FRONT OF VEHICLE

**TURN KNOB TO ADJUST TO
YOUR LADDER.**

**DO NOT OVER TIGHTEN!
CLAMP PAD SHOULD JUST
TOUCH THE LADDER.**



DDL6 Series Final Adjustment Instruction (GMFSV / Ford Transit)

**DOUBLE CHECK ALL FASTENERS LOCATIONS TO BE SURE THAT ALL FASTENERS ARE
TIGHTENED TO SPECIFICATIONS.**

YOUR INSTALLATION IS NOW COMPLETE!

STOW THIS COPY IN THE VEHICLE FOR FUTURE REFERENCES!

Introduction / Comments:

THIS DROP DOWN UNIT IS CURB SIDE, STREET SIDE SPECIFIC. THE DROP DOWN IS FOR LOW ROOF VEHICLES, THESE INSTRUCTIONS WILL BE SHOWING THE GM FSV AND SOME FORD TRANSIT PICTURES FOR THE VEHICLE REPRESENTATION. THIS DROP DOWN LADDER RACK IS DESIGNED TO ADAPT TO AN ADRIAN STEEL CROSS BOW KIT FOR VARIOUS STANDARD ROOF VEHICLES.

Note:

It is advised that all fasteners used in this assembly and installation of this Rack should be checked for tightness at the following intervals: @ 2-weeks and again @ 6-weeks of operation. This preventive maintenance step must be completed to ensure your package gives you long service life.

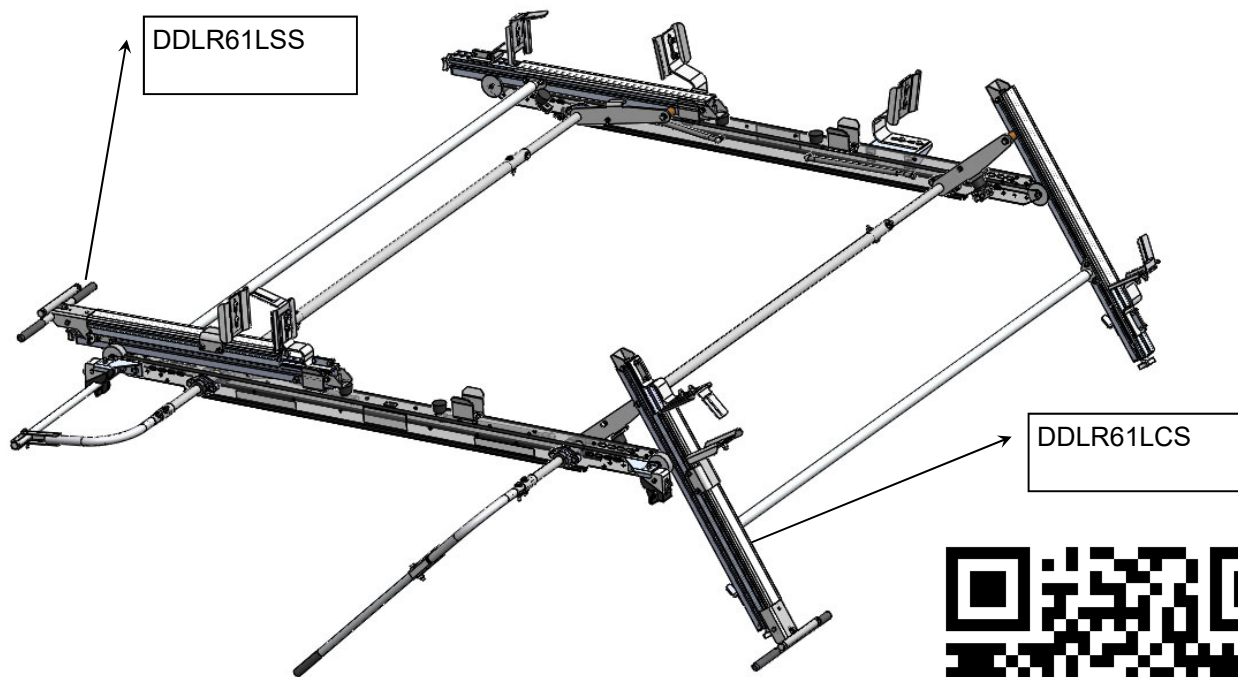

TO VIEW INSTALL VIDEO

**DDL61GM / DDL63GM
FINAL DROP DOWN LADDER RACK, STREET, CURB
GM FSV, LOW ROOF VAN**

- PRECAUTIONS -





 **CAUTION** 
**THE USE OF AIR IMPACT TOOLS CAN
OVER-TORQUE FASTENERS AND
CAUSE FASTENER FAILURE!**



 **CAUTION** 
**ALL INSTALLATION HOLES SHOULD BE SEALED
WITH SILICON OR BUTYL SEALANT TO PREVENT
EXHAUST FUMES FROM ENTERING THE VEHICLE!**



 **DANGER** 
**INSPECT FOR FUEL TANK, FUEL LINES, BRAKE LINES, HIGH
VOLTAGE BATTERIES AND ELECTRICAL LINES PRIOR TO
DRILLING TO AVOID DAMAGING CRITICAL VEHICLE SYSTEMS
OR INJURY TO INSTALLER DURING INSTALLATION PROCESS!**



 **CAUTION** 
**TO AVOID DAMAGING THE VEHICLE ALWAYS
USE DRILL STOPS WHEN DRILLING ANY IN-
STALLATION HOLES!**



- IMPORTANT WARRANTY REQUIREMENTS -

1. SUBSTITUTING ADRIAN STEEL SPECIFIED FASTENERS FOR ASSEMBLY AND/OR INSTALLATION WILL VOID YOUR PRODUCT WARRANTY.
2. ALL HOLES DRILLED INTO VEHICLE SHOULD HAVE THE RAW METAL EDGES SEALED WITH A SELF-ETCHING PRIMER TO RESIST CORROSION AND POTENTIAL FASTENER POINT FAILURE.
3. ALL FASTENERS USED IN THE INSTALLATION OF THIS PRODUCT SHOULD BE TIGHTENED TO THE TORQUE(S) SPECIFIED IN THESE INSTRUCTIONS.
4. THESE INSTRUCTIONS SHOULD BE KEPT WITH THE VEHICLE.

THE BASIC TOOLS NEEDED FOR MOST INSTALLATIONS



DRILL



DRILL BIT WITH
STOP

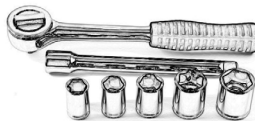

RATCHET, SOCKETS
AND/OR WRENCHES



SCREWDRIVERS



MEASURING TAPE

ADDITIONAL TOOLS MAY BE NEEDED FOR THIS INSTALLATION AND THEY WILL BE IDENTIFIED IN THE STEPS THAT FOLLOW.

BAG51041—FINAL ASSEMBLY FASTENER BAG

ITEM NO.	PART NUMBER	DESCRIPTION	QTY.
1	BAG0507-A	5" x 7" 3MIL AUTOBAG	1
2	FAS0246	Washer, Flat, 3/8, HRD, ZN	6
3	FAS0799	Screw, Hex Hd, 5/16-18x0.75 SS	4
4	FAS0110	Nut,Hex Nylk 3/8-16 SS W	4
5	FAS0572	Screw, Button Hd Hex Soc, 3/8-16x1.00 NI-ZN	2
6	FAS0588	Washer, Lock, Split, 5/16, SS	4
7	FAS0286	SCREW, HHCS, 3/8-16x4, SS	2
8	FAS0287	COTTER PIN, 1/16DIA X 1"LG, SS	2

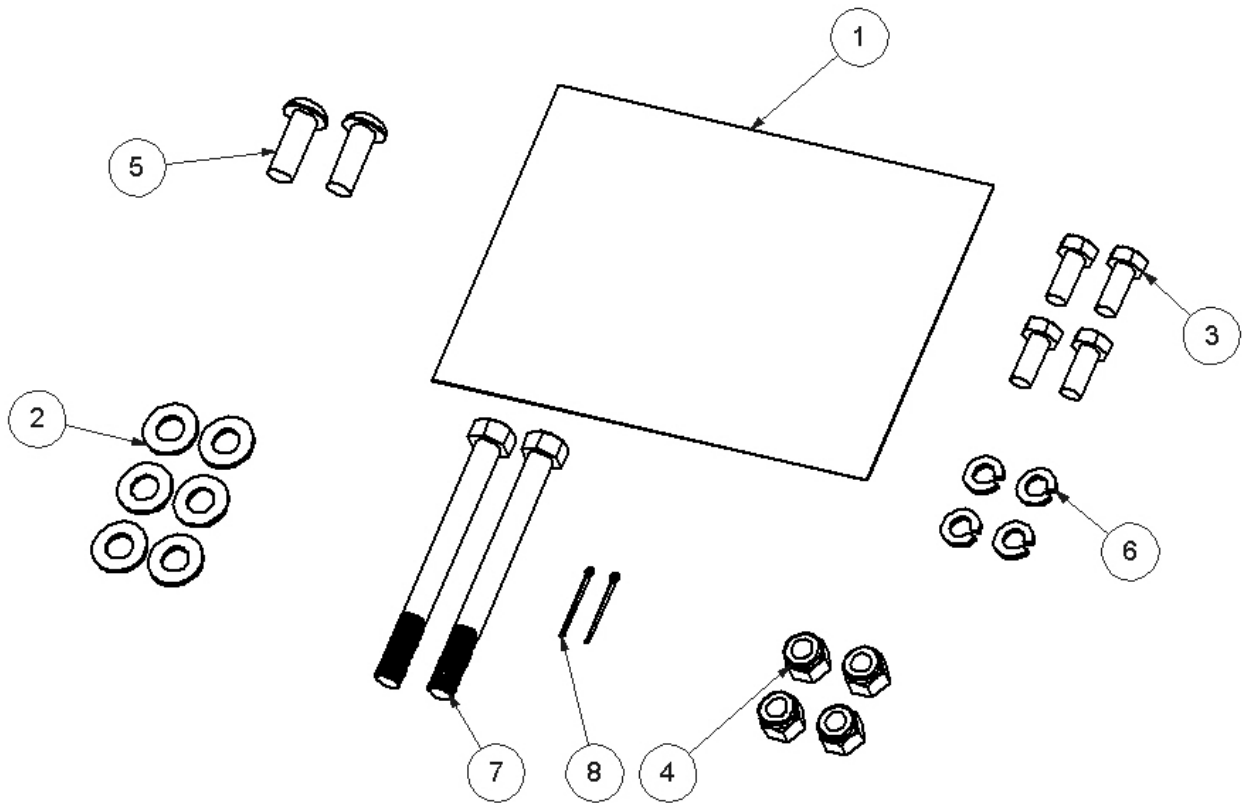



STEP 1A : THIS IS THE SHIP THRU SINGLE DROP DOWN AS YOU WOULD RECEIVE FOR FINAL DEALER ASSEMBLY. SEE STEP 1B FOR DOUBLE DROP DOWN.

SHOWING A GM FSV
RRKGMFSV
CROSS BOW KIT
ORDERED
SEPERATELY





STEP 1B : THIS IS THE SHIP THRU DOUBLE DROP DOWN AS YOU WOULD RECEIVE FOR FINAL DEALER ASSEMBLY

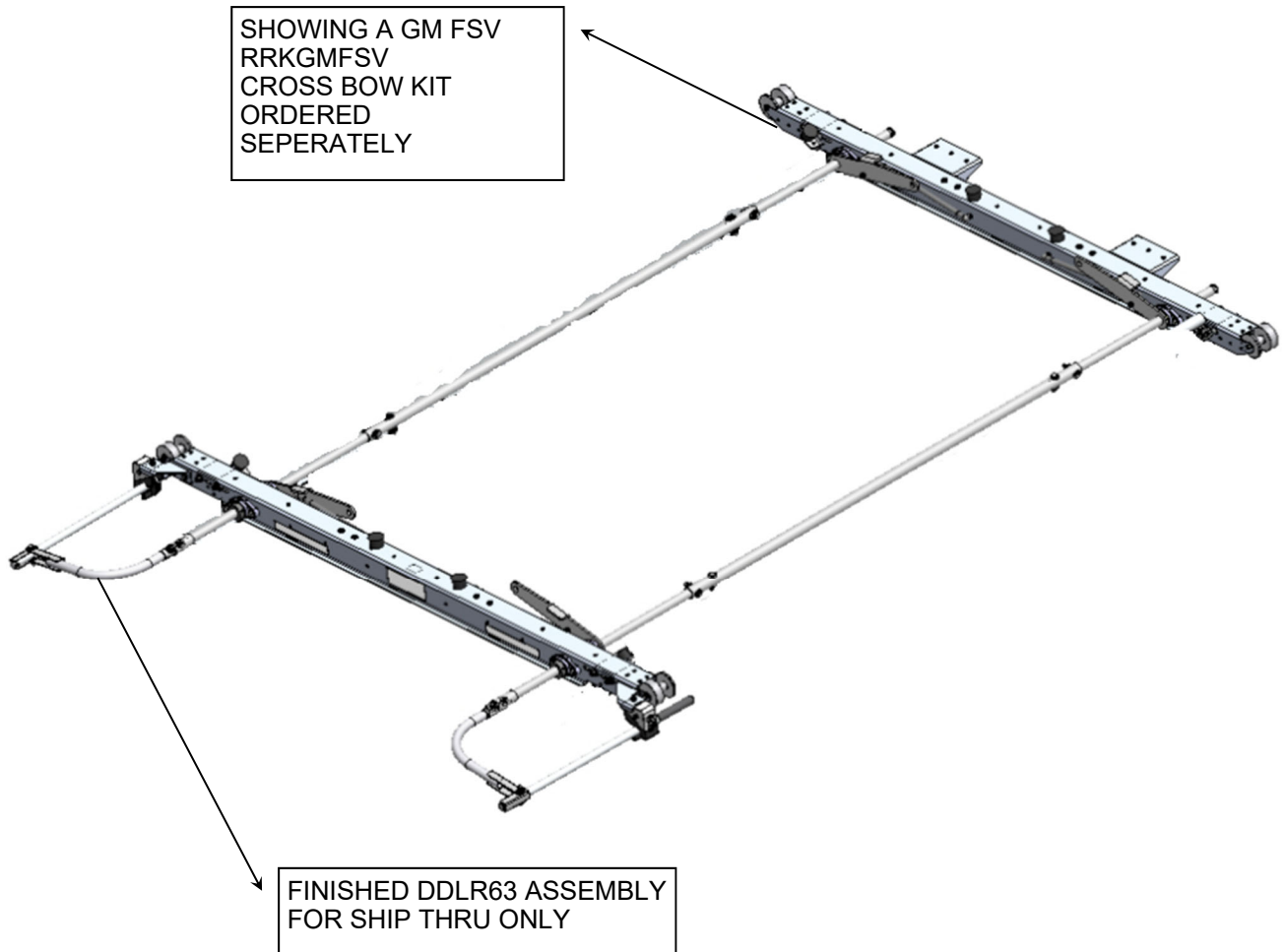

STEP 2 - THIS IS THE FINAL ASSEMBLY, SHOWING THE CURB AND STREET SIDE DROP DOWN COMPONENTS

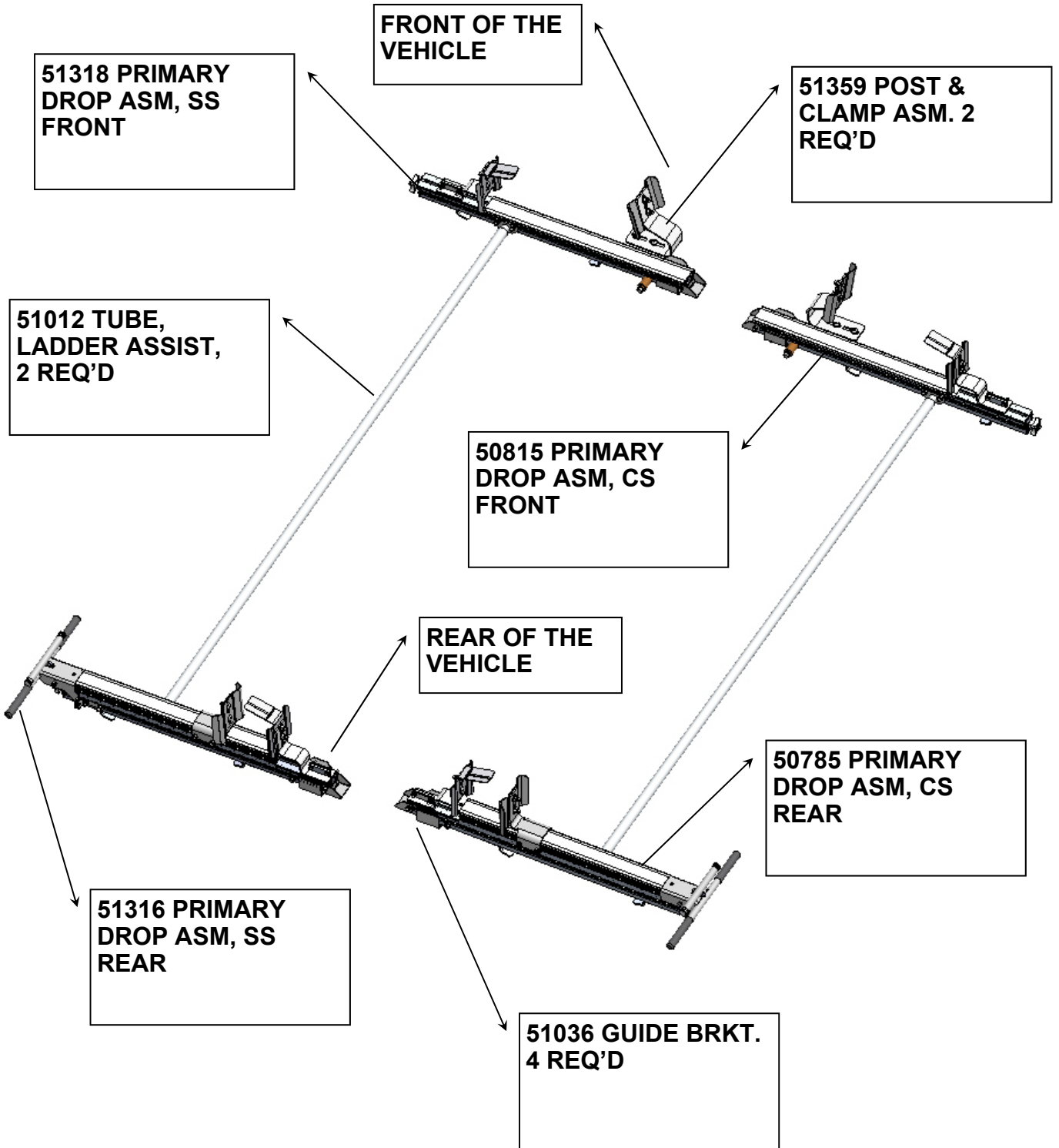

STEP 3 : ASSEMBLE BRACKETS TO THE FRONT CROSS BOW

NOTE: ITEM 51036 WILL VARY APPEARANCE AS EITHER VIEW OF 54178 SHOWN BELOW.

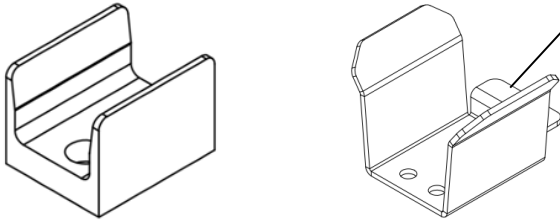

IF USING THIS STYLE, ENSURE THE REST FLANGE IS MOUNTING FACING TO THE OUTSIDE OF THE LADDER RACK! THIS WILL GIVE CLEARANCE FOR A CONDUIT KIT TO BE MOUNTED IN THE CENTER.

FAS0799— 5/16 X .75 HHCS
FAS0588— 5/16 LW
(2) EACH, 4 PLACES
THRU FRONT HOLES OF FRONT BRKTS AND REAR HOLES FOR REAR BRKTS INTO RIVNUTS IN CROSS BOWS

51359 POST & CLAMP
ASM
2 PLACES

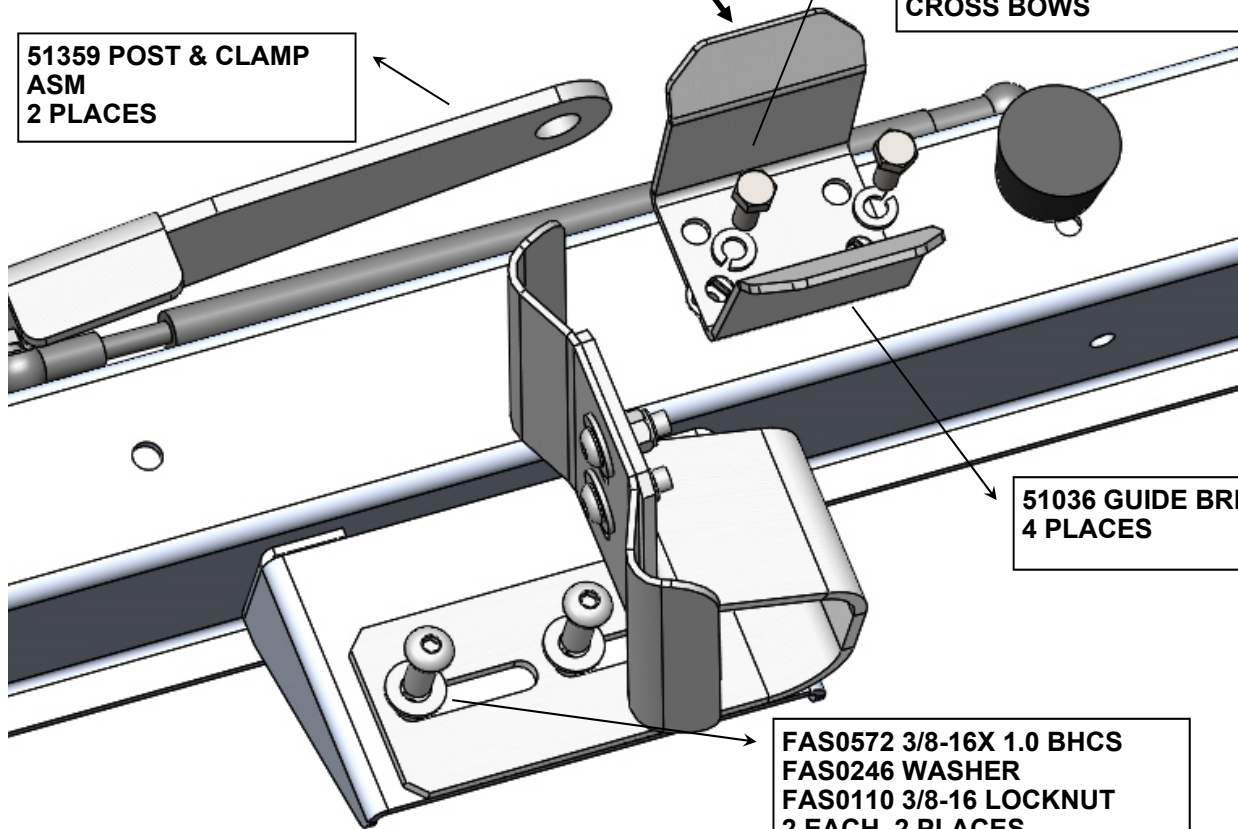

51036 GUIDE BRKT
4 PLACES

FAS0572 3/8-16X 1.0 BHCS
FAS0246 WASHER
FAS0110 3/8-16 LOCKNUT
2 EACH, 2 PLACES

COMPLETED VIEW OF THE FRONT CROSS BOW

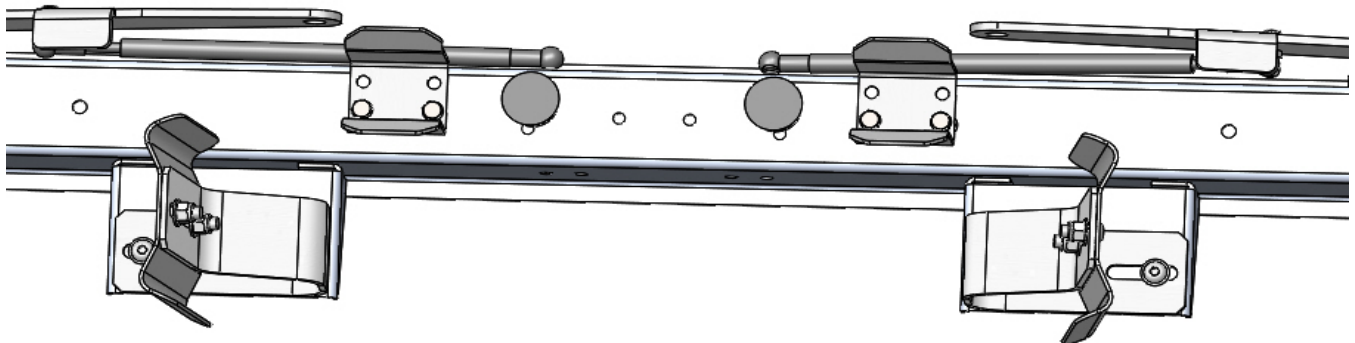

STEP 4 : ASSEMBLE REAR CURB SIDE PRIMARY DROP TO RACK

**SET 50785 PRIMARY DROP ASM, REAR CS IN PLACE ON REAR CROSS BOW.
USE GUIDE ROLLER TO HELP LOAD INTO POSITION**

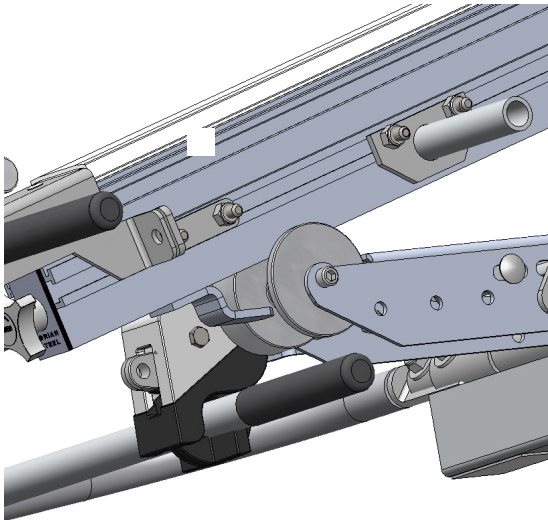

**50785 PRIMARY DROP
ASM CS REAR**

**50785 PRIMARY DROP
ASM, CS REAR**

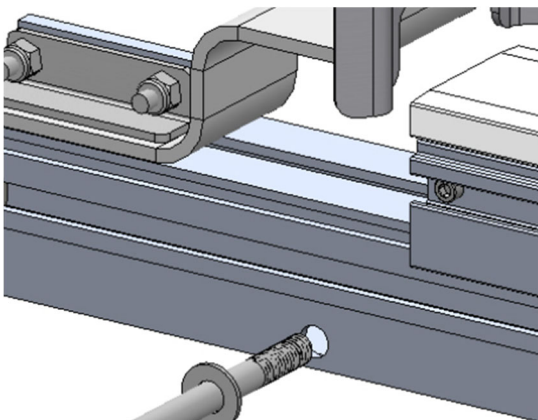
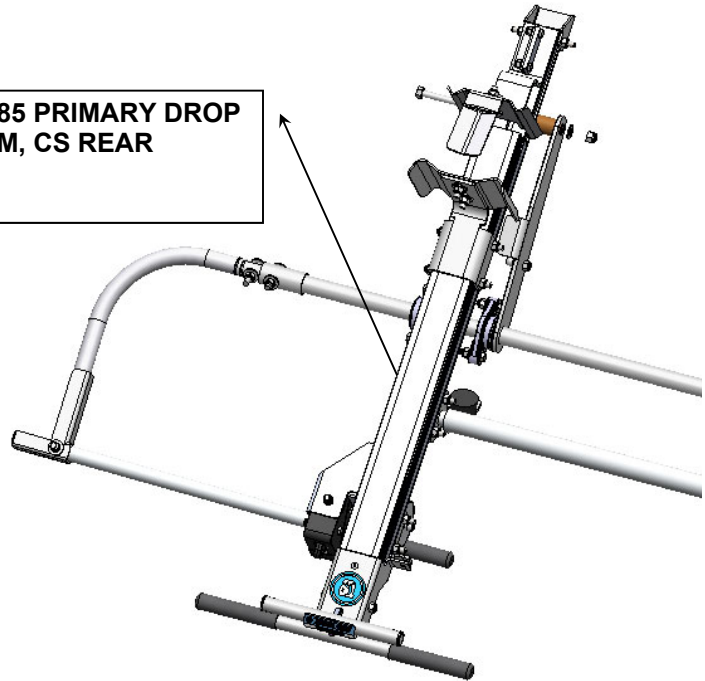

**FAS02826 3/8-16 X 4" HHCS
FAS0246 WASHER**

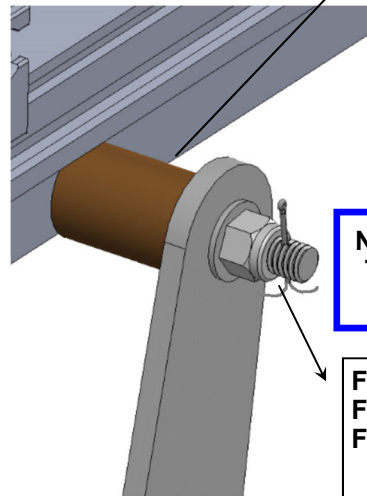

**51034 BRONZE
BUSHING**

**NOTE: TORQUE NYLOCK NUT
TO 20FT.LBS, THEN INSERT/
SECURE THE COTTER PIN.**

**FAS0246 WASHER
FAS0110 3/8-16 NYLOCK NUT
FAS0287—COTTER PIN**

**NOTE: AFTER THE COTTER
PIN IS INSERTED THROUGH
THE BOLT, SPREAD THE PIN
SO IT CAN NOT BE REMOVED.**

STEP 5 : ASSEMBLE FRONT SIDE PRIMARY DROP TO RACK

**SET 50815 PRIMARY DROP ASM, FRONT CS IN PLACE ON FRONT CROSS BOW.
USE GUIDE ROLLER AFTER LADDER ASSIST TUBE IS ON BOTH STUB SHAFTS**

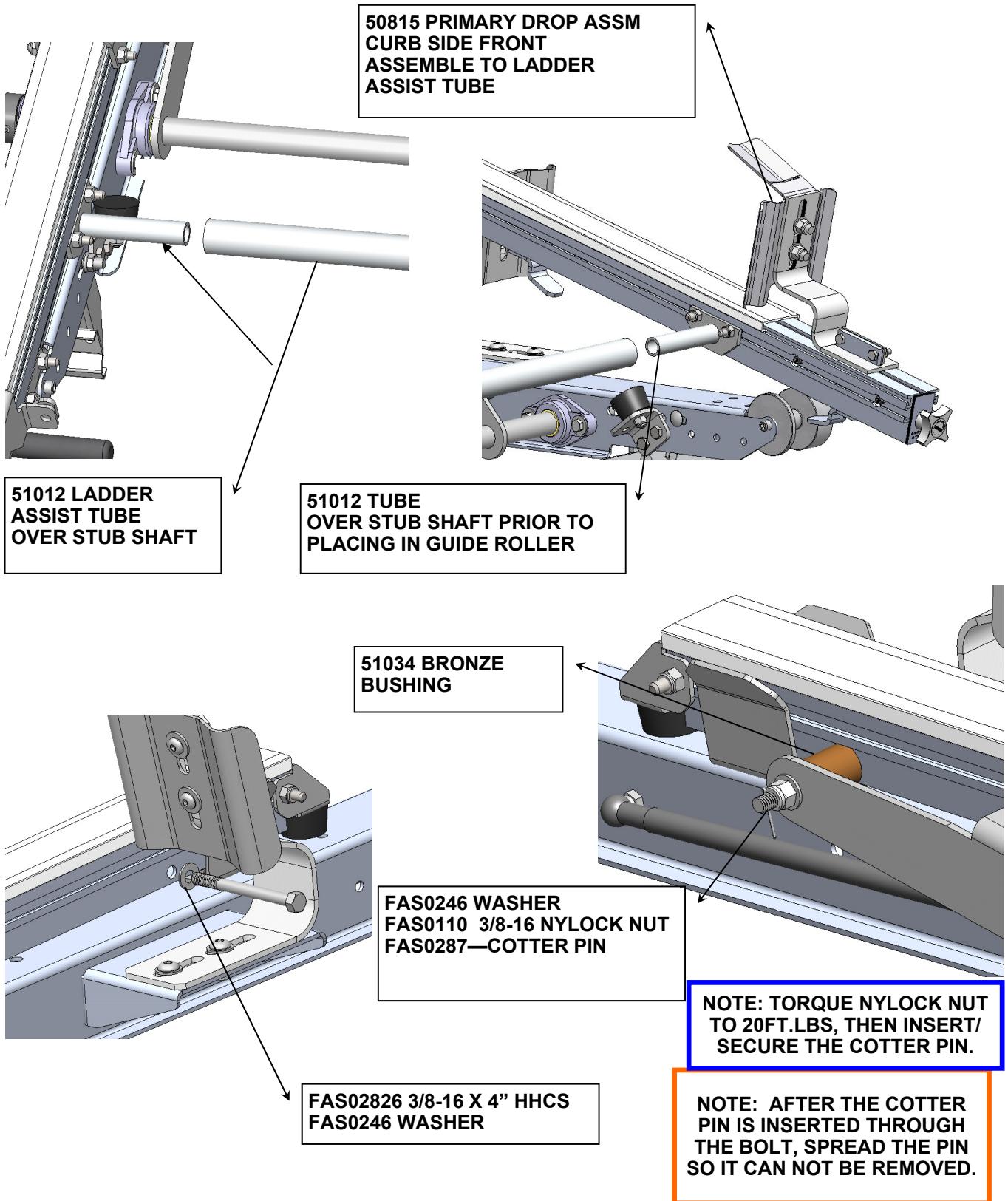



**STEP #6 : FOR A DOUBLE DROP DOWN, INSTALL STREET SIDE USING
STEPS #4 & #5 AS YOUR GUIDE.**

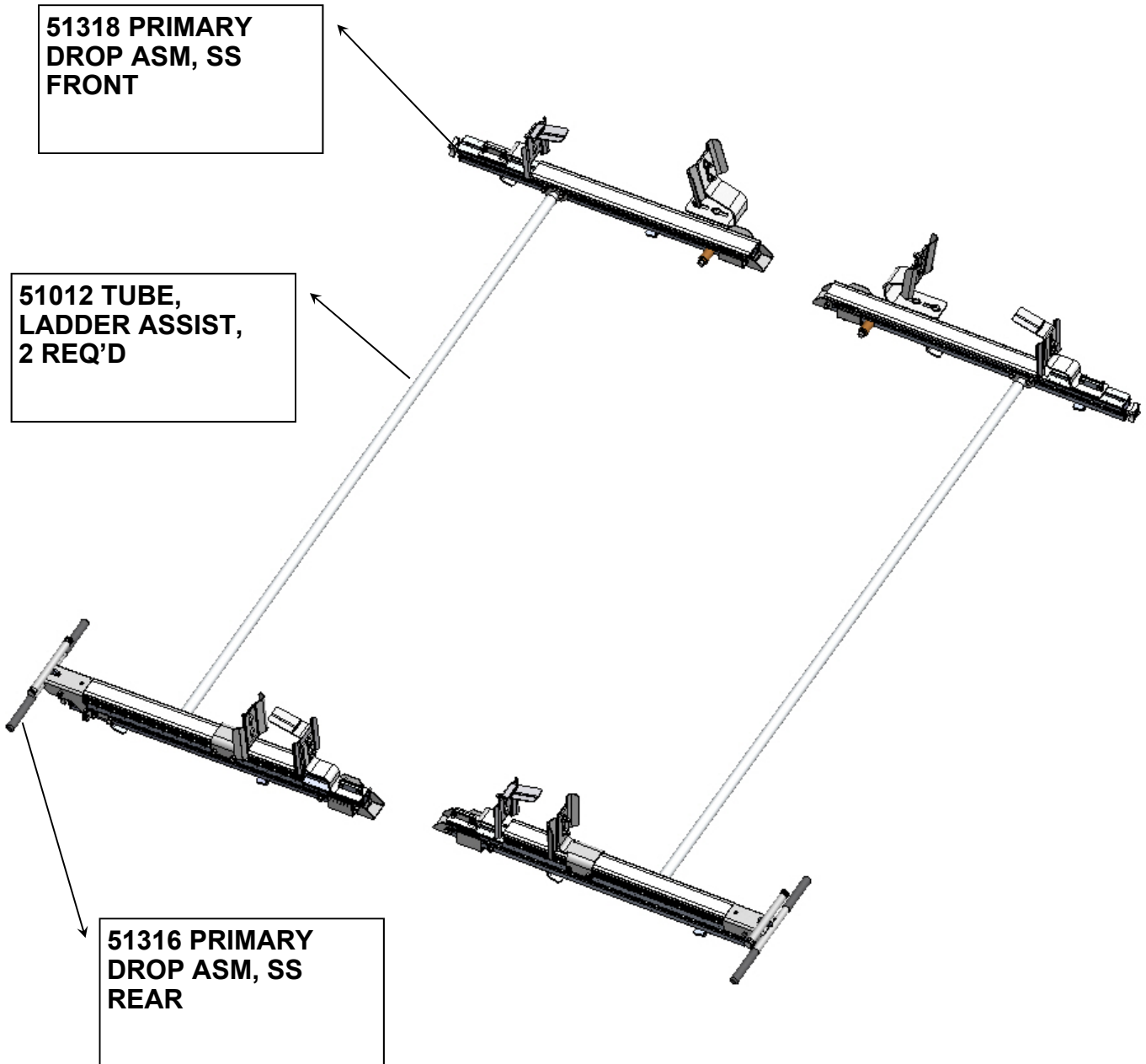

**DOUBLE CHECK ALL FASTENERS LOCATIONS TO BE SURE THAT ALL
FASTENERS ARE TIGHTENED TO SPECIFICATIONS.
YOUR INSTALLATION IS NOW COMPLETE!
STOW THIS COPY IN THE VEHICLE FOR FUTURE REFERENCES!**



**STEP #7 : YOUR DOUBLE DROP DOWN INSTALLATION IS NOW COMPLETE
FOR A COMBO RACK, GO TO STEP 8**



**DOUBLE CHECK ALL FASTENERS LOCATIONS TO BE SURE THAT ALL
FASTENERS ARE TIGHTENED TO SPECIFICATIONS.
YOUR INSTALLATION IS NOW COMPLETE!
STOW THIS COPY IN THE VEHICLE FOR FUTURE REFERENCES!**



STEP #08 : COMBO RACK, FINAL INSTALL- STREET SIDE GRIP LOCK



STEP #9 : COMBO RACK, INSTALL STREET SIDE GRIP LOCK

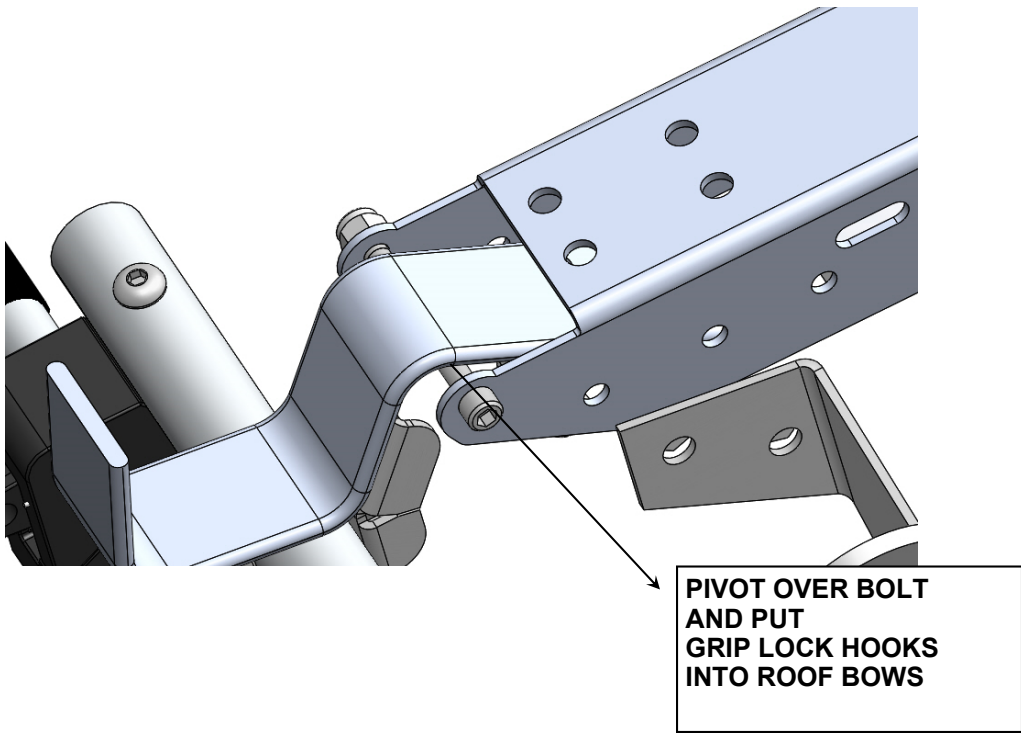

SECOND AND THIRD HOLES !
FAS0799— 5/16 x 3/4 HHCS (2)
FAS0248— NYLOCK (2)

REAR ROOF BOW

FAS0820— 3/8 X 1 LG BHCS (4)
FAS0110— NYLOCK (4)

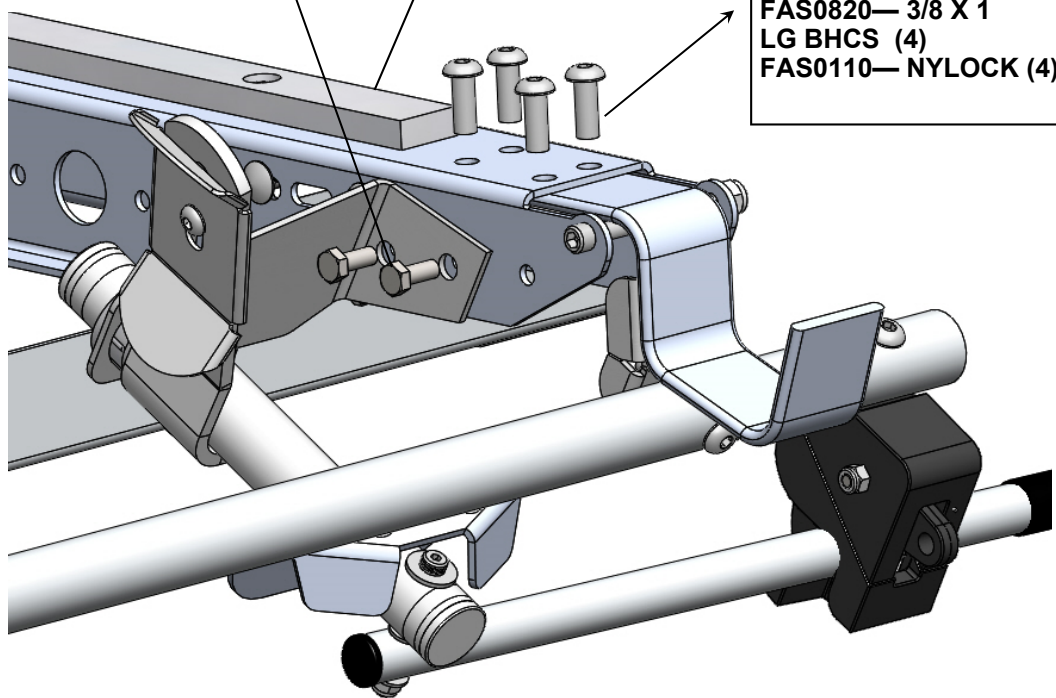

STEP #10: FRONT ROOF BOW ASSEMBLY –STREET SIDE

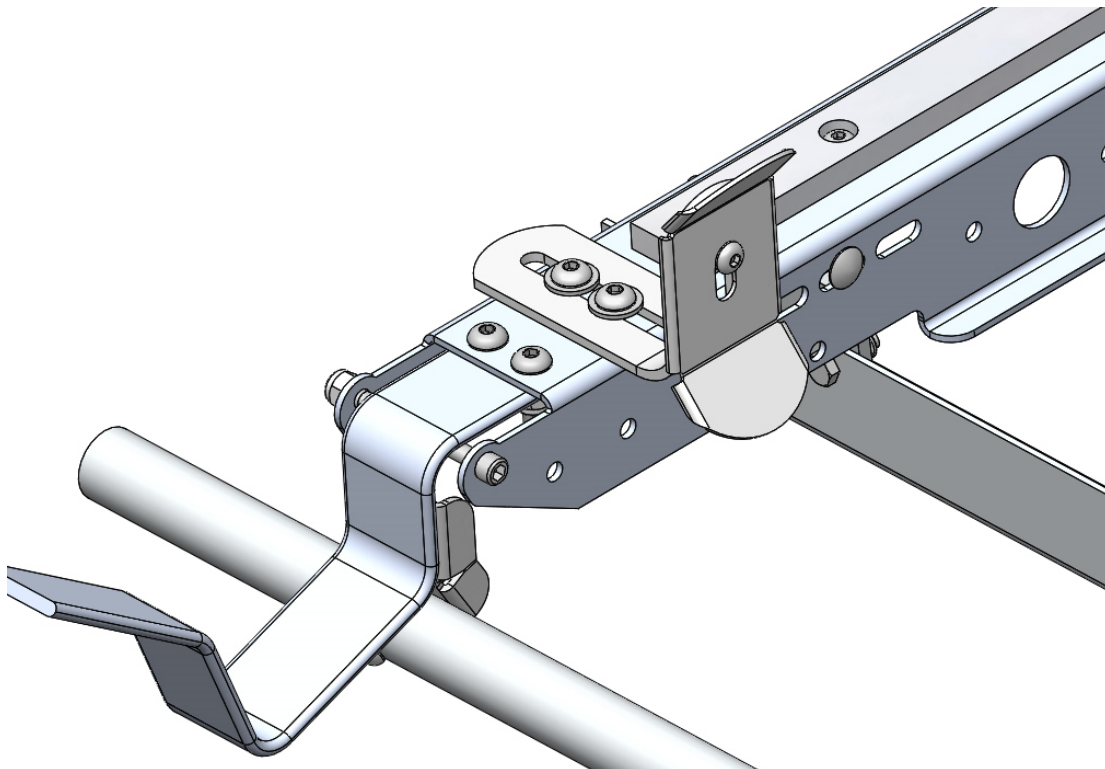
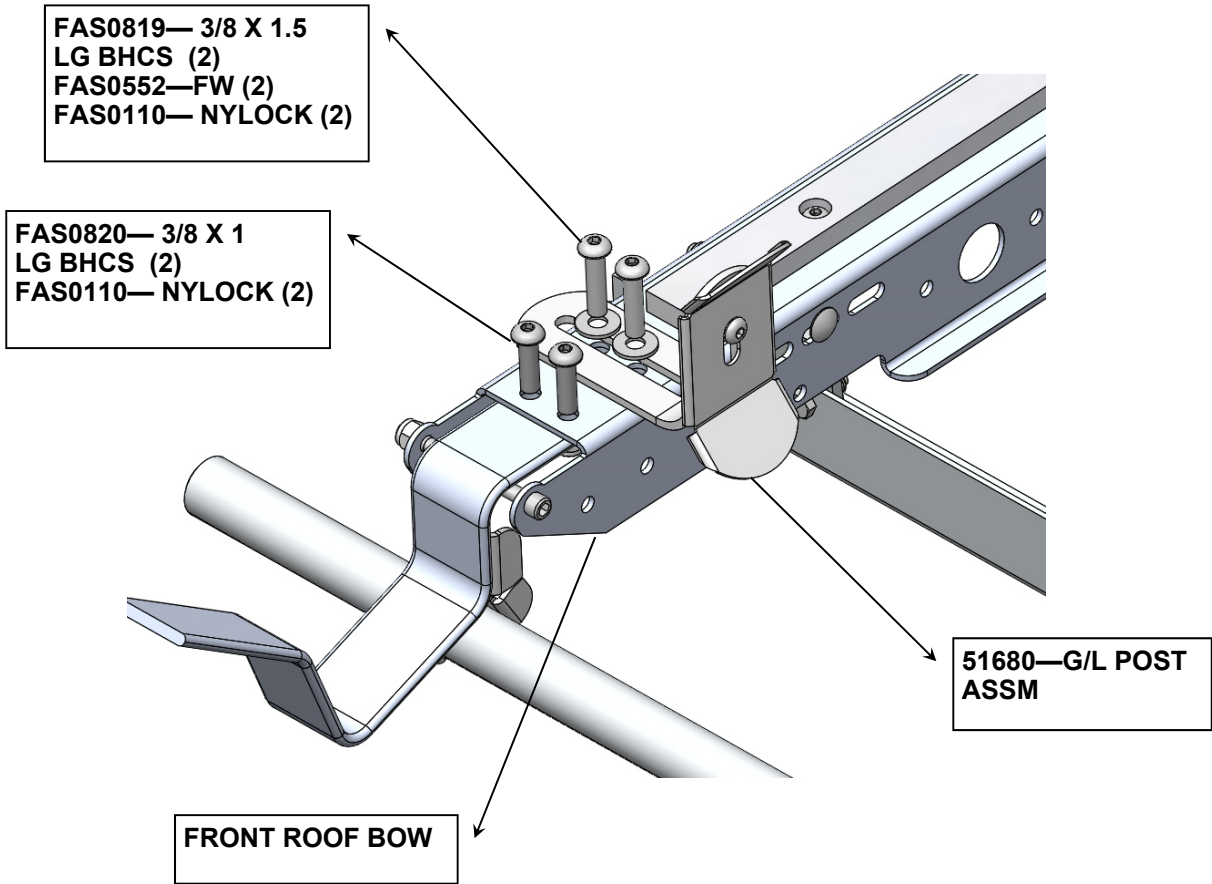

STEP #23 : YOUR DROP DOWN COMBO INSTALLATION IS NOW COMPLETE



**DOUBLE CHECK ALL FASTENERS LOCATIONS TO BE SURE THAT ALL
FASTENERS ARE TIGHTENED TO SPECIFICATIONS.
YOUR INSTALLATION IS NOW COMPLETE!
STOW THIS COPY IN THE VEHICLE FOR FUTURE REFERENCES!**

**REAR CLAMP PAD MOVES TOWARDS CURB TO
TIGHTEN LADDER TO RACK**

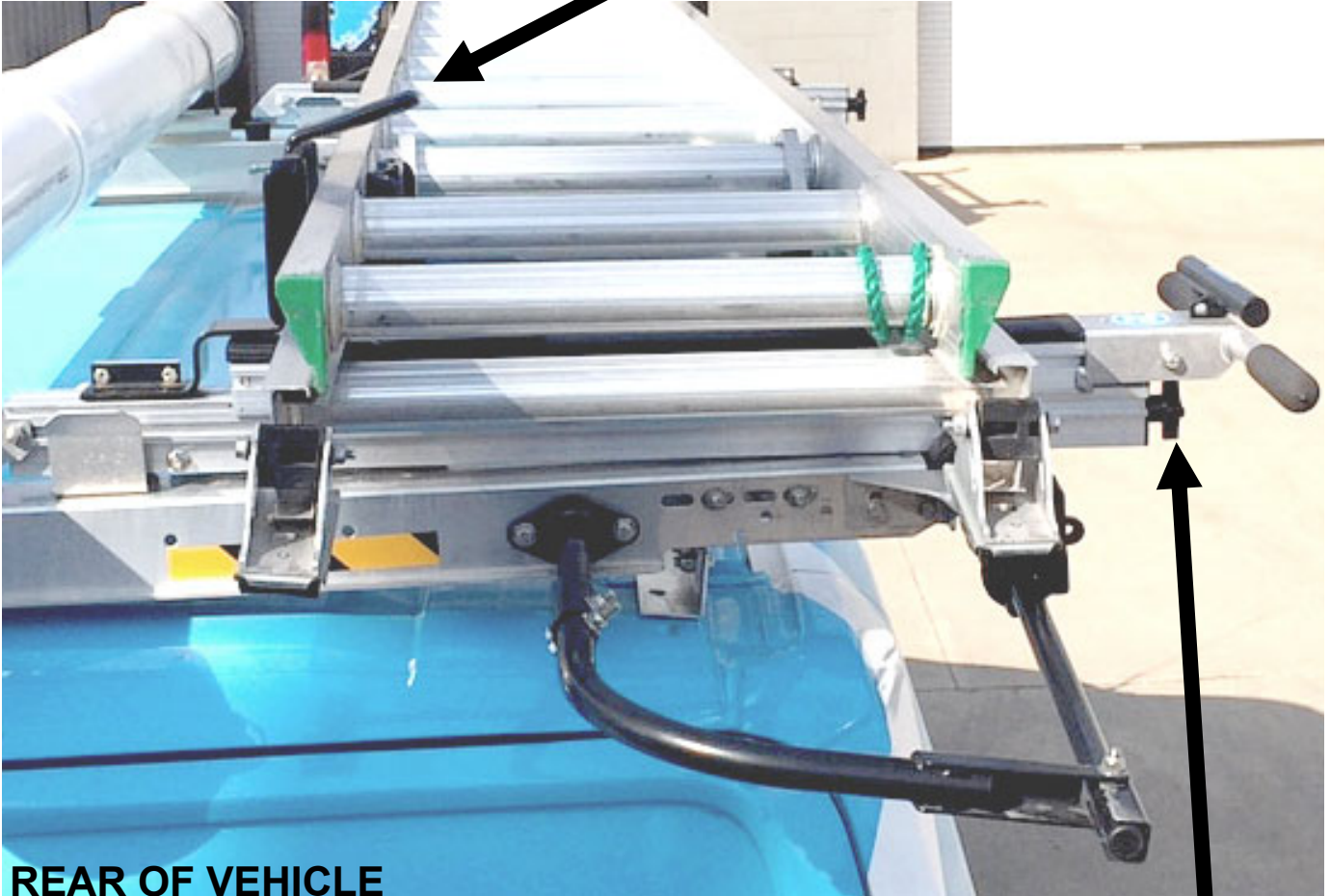

REAR OF VEHICLE



**TURN KNOB TO ADJUST TO
YOUR LADDER.**

**DO NOT OVER TIGHTEN!
CLAMP PAD SHOULD JUST
TOUCH THE LADDER.**

DDL61 Series Final Adjustment Instruction (GMFSV / Ford Transit)

Proper Clamp Pad Locations

Below is the proper way to clamp the ladder to the vehicle (highlighted in green)

How to inspect for this: Properly placed clamp pads should be in close proximity to each other to allow the clamp pads to securely retain the ladder from side to side motion and front to back motion.

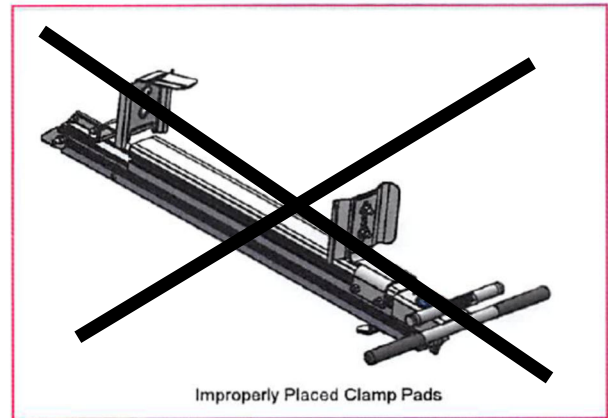
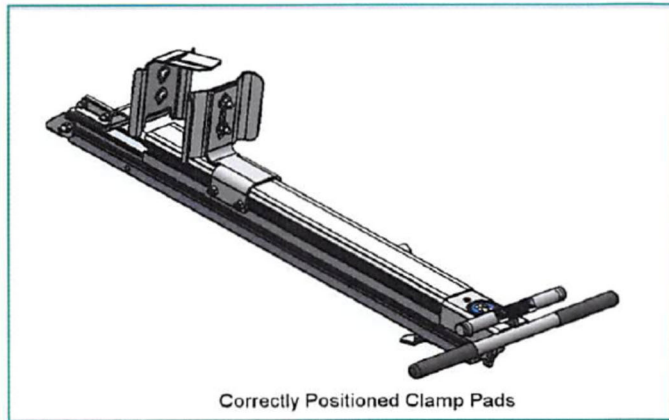

Above is the wrong way to clamp the ladder to the vehicle

**FRONT CLAMP PAD MOVES TOWARDS STREET
TO TIGHTEN LADDER TO RACK**



**TURN KNOB TO ADJUST TO
YOUR LADDER.**

**DO NOT OVER TIGHTEN!
CLAMP PAD SHOULD JUST
TOUCH THE LADDER.**



DDL61 Series Final Adjustment Instruction (GMFSV / Ford Transit)

**DOUBLE CHECK ALL FASTENERS LOCATIONS TO BE SURE THAT ALL FASTENERS ARE
TIGHTENED TO SPECIFICATIONS.**

YOUR INSTALLATION IS NOW COMPLETE!

STOW THIS COPY IN THE VEHICLE FOR FUTURE REFERENCES!

STEP #10A: HOW TO ADJUST THE CLAMP PADS

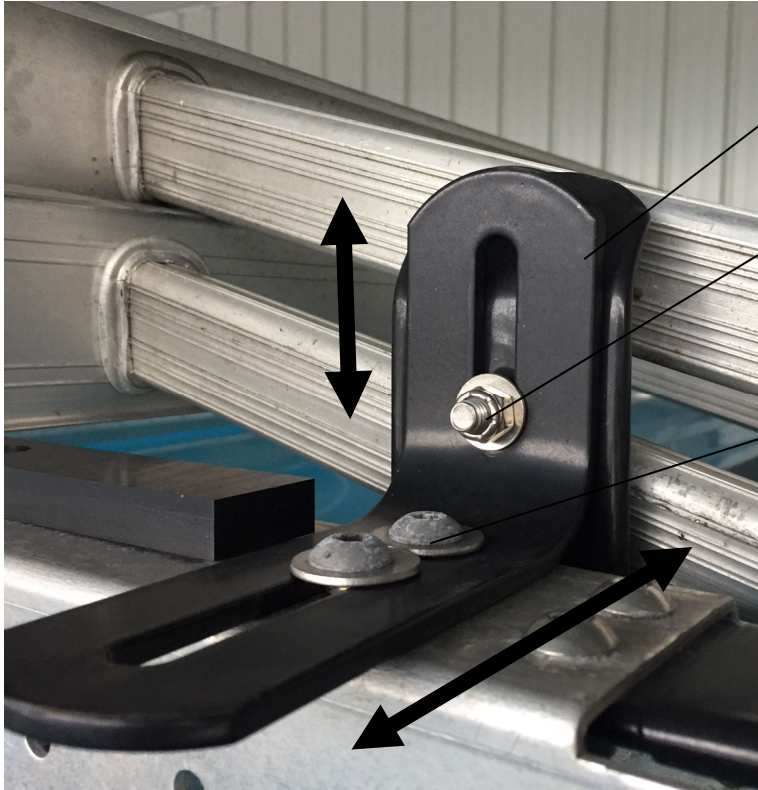

FRONT BRACKET

ADJUST VERTICALLY TO YOUR LADDER

ALL OF THE HORIZONTAL ADJUSTMENT IS IN THIS BRACKET.

REAR LOCKING PIVOT BRACKET

ADJUST VERTICALLY TO YOUR LADDER. SHOWING A STEP LADDER

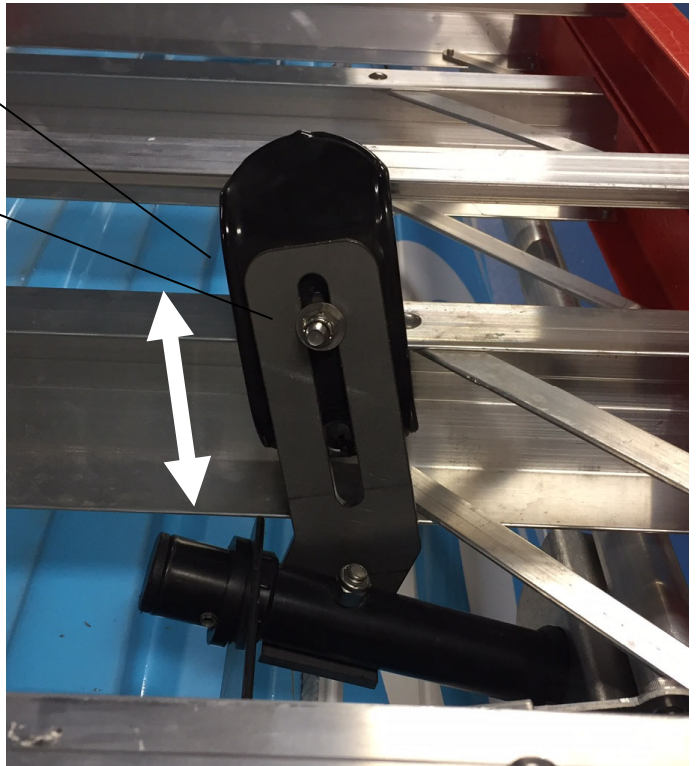

**DOUBLE CHECK ALL FASTENERS LOCATIONS TO BE SURE THAT ALL FASTENERS ARE TIGHTENED TO SPECIFICATIONS.
YOUR INSTALLATION IS NOW COMPLETE!
STOW THIS COPY IN THE VEHICLE FOR FUTURE REFERENCES!**

STEP #10B : HOW TO ADJUST THE CLAMP PADS

- A) Load your ladder onto the ladder rack (see page 14) and latch the HANDLE BAR into the HANDLE LATCH.
- B) Now slide the ladder back towards the rear of the vehicle and slide the rear CLAMP BRACKET to fit snug over and against the top ladder rung. ** See bottom illustration for STEP LADDERS ! **
SEE ILLUSTRATION BELOW.
- C) Next slide the FRONT STOP POST at the front of the ladder rack back towards the rear of the vehicle and fit the front CLAMP BRACKET to the top ladder rung the same as the rear.
- D) Firmly tighten both front and rear CLAMP BRACKETS to their posts and tighten snug the FRONT STOP POST to the front CROSS SUPPORT.
- E) Now unlatch the HANDLE BAR and unload your ladder. Next loosen the FRONT STOP POST and slide it out towards the rear of the vehicle 1/2" and FIRMLY RETIGHTEN !
YOUR LADDER RACK SHOULD NOW BE ADJUSTED FOR YOUR LADDER.

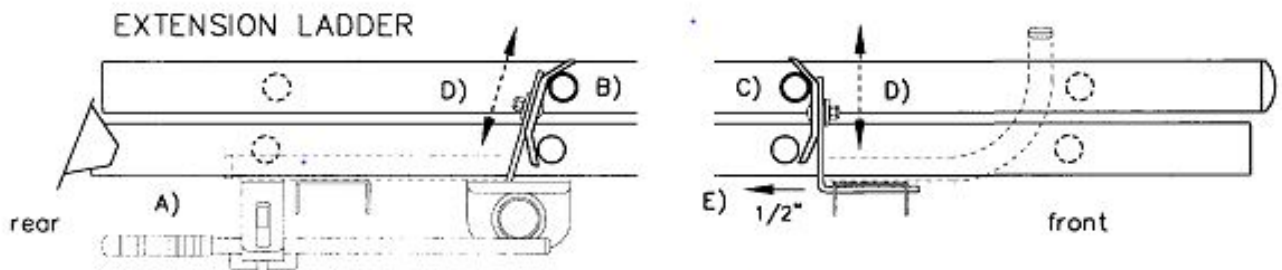

CAUTION: Never clamp up the first step and the head of the STEP LADDER !

Front CLAMP BRACKET must be attached like this !

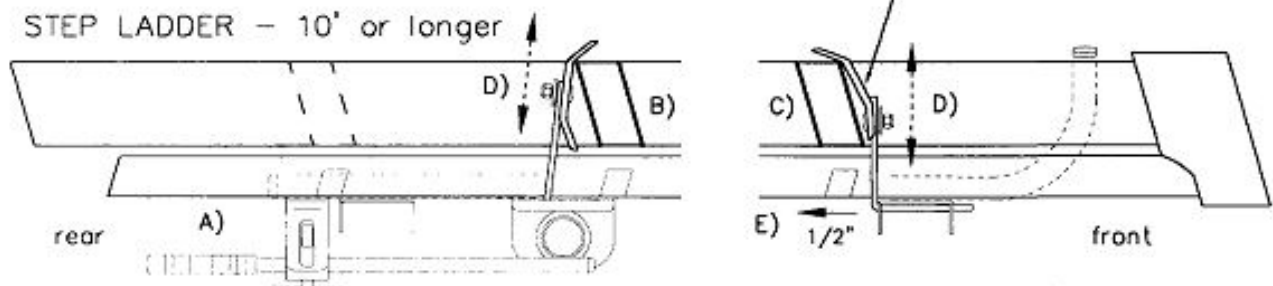

**DOUBLE CHECK ALL FASTENERS LOCATIONS TO BE SURE THAT ALL FASTENERS ARE TIGHTENED TO SPECIFICATIONS.
YOUR INSTALLATION IS NOW COMPLETE!
STOW THIS COPY IN THE VEHICLE FOR FUTURE REFERENCES!**

Introduction / Comments:

PROMASTER LOW ROOF CROSSBOW/ROOF RAIL ASSEMBLY INSTRUCTIONS

Note:

It is advised that all fasteners used in this assembly and installation should be checked for tightness at the following intervals: @ 2-weeks and again @ 6-weeks of operation. This preventive maintenance step must be completed to ensure your Product gives you long service life.



RRKPM118

RRKPM136



RRKPM118 / RRKPM136

PROMASTER LOW ROOF CROSSBOW/ROOF RAIL KIT

- PRECAUTIONS -



CAUTION
THE USE OF AIR IMPACT TOOLS CAN OVER-TORQUE FASTENERS AND CAUSE FASTENER FAILURE!



CAUTION
ALL INSTALLATION HOLES SHOULD BE SEALED WITH SILICON OR BUTYL SEALANT TO PREVENT EXHAUST FUMES FROM ENTERING THE VEHICLE!



DANGER
INSPECT FOR FUEL TANK, FUEL LINES, BRAKE LINES, HIGH VOLTAGE BATTERIES AND ELECTRICAL LINES PRIOR TO DRILLING TO AVOID DAMAGING CRITICAL VEHICLE SYSTEMS OR INJURY TO INSTALLER DURING INSTALLATION PROCESS!



CAUTION
TO AVOID DAMAGING THE VEHICLE ALWAYS USE DRILL STOPS WHEN DRILLING ANY INSTALLATION HOLES!
ADRIAN AVAILABLE PART #'S 31119-0 (3/8" X 1/2" DEEP), 31121-0 (1/2" x 1/2" DEEP)



- IMPORTANT WARRANTY REQUIREMENTS -

1. SUBSTITUTING ADRIAN STEEL SPECIFIED FASTENERS FOR ASSEMBLY AND/OR INSTALLATION WILL VOID YOUR PRODUCT WARRANTY.
2. ALL HOLES DRILLED INTO VEHICLE SHOULD HAVE THE RAW METAL EDGES SEALED WITH A SELF-ETCHING PRIMER TO RESIST CORROSION AND POTENTIAL FASTENER POINT FAILURE.
3. ALL FASTENERS USED IN THE INSTALLATION OF THIS PRODUCT SHOULD BE TIGHTENED TO THE TORQUE(S) SPECIFIED IN THESE INSTRUCTIONS.
4. THESE INSTRUCTIONS SHOULD BE KEPT WITH THE VEHICLE.

THE BASIC TOOLS NEEDED FOR MOST INSTALLATIONS



DRILL



DRILL BIT WITH STOP



RATCHET, SOCKETS AND/OR WRENCHES



SCREWDRIVERS



MEASURING TAPE

ADDITIONAL TOOLS MAY BE NEEDED FOR THIS INSTALLATION AND THEY WILL BE IDENTIFIED IN THE STEPS THAT FOLLOW.

If your vehicle contains carpet or a rubber floor mat you will need to prepare the mounting location. Position the product to be installed into the vehicle and once you are satisfied with the mounting locations, mark the mounting locations. Using a 1-3/16" diameter carpet cutter (P/N: 31183-0). Select the appropriate floor spacers as shown in the illustration. Set those aside for use later into the installation process.

Using the correct drill bit size for the selected plusnut, drill the mounting holes in the vehicle sheet metal to prepare for installing the plusnuts.

If you are thru-bolting at any of the locations simply drill a hole that is 1/16" larger than the bolt size(s) for those locations.

Once you have drilled the holes into the vehicle, the raw metal edges should be sealed using a self-etching primer to resist corrosion and potential fastener point failure.

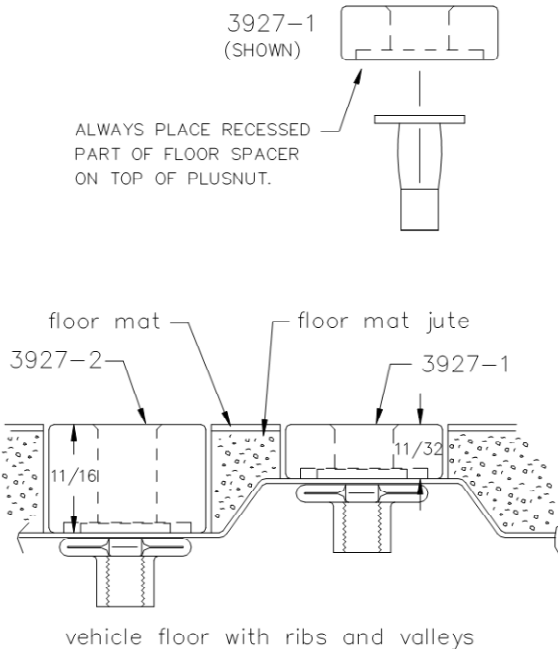

A PLUSNUT (RIVNUT) SETTING TOOL IS REQUIRED FOR PLUSNUT (RIVNUT) INSTALLATION . PLUS NUT SETTING TOOL CAN BE ORDERED THROUGH ADRIAN STEEL, OR USE AN AIR POWERED PLUSNUT SETTING GUN.

1/4-20UNC Plusnut (FAS0052) Use 3/8" dia. drill w/stop
 FAS0080 SCREW, HXHD, 1/4-20UNCx2.00", G8
 FAS0067 WASHER, FLAT, 1/4"ID
 22200-0 PLUSNUT TOOL

5/16-18UNC Plusnut (FAS0091) Use 1/2" dia. drill w/stop
 FAS0095 SCREW, HXHD, 5/16-18UNCx2.00", G8
 FAS0086 WASHER, FLAT, 5/16"ID
 22200-0 PLUSNUT TOOL

Place barrel of the plusnut body in sheet metal thru hole until flange is flush with sheet metal.
 Using a 9/16" combination wrench of plusnut tool body and a second hand wrench, ratchet, or air tool, rotate the hex bolt head CW to draw plus nut flanges up (set the plusnut).

**ASSEMBLY FASTENERS
BAGPMLRRK**

ITEM NO.	PART NUMBER	DESCRIPTION	QTY
1	FAS0242	SCREW,HH 5/16-18X1.5 SS	6
2	FAS0552	WASHER,FLAT USS 5/16 SS	6
3	FAS0588	WASHER,LCK SPLIT 5/16 SS	6
4	BAG0509-A	6"X10" 4MIL AUTOBAG	1

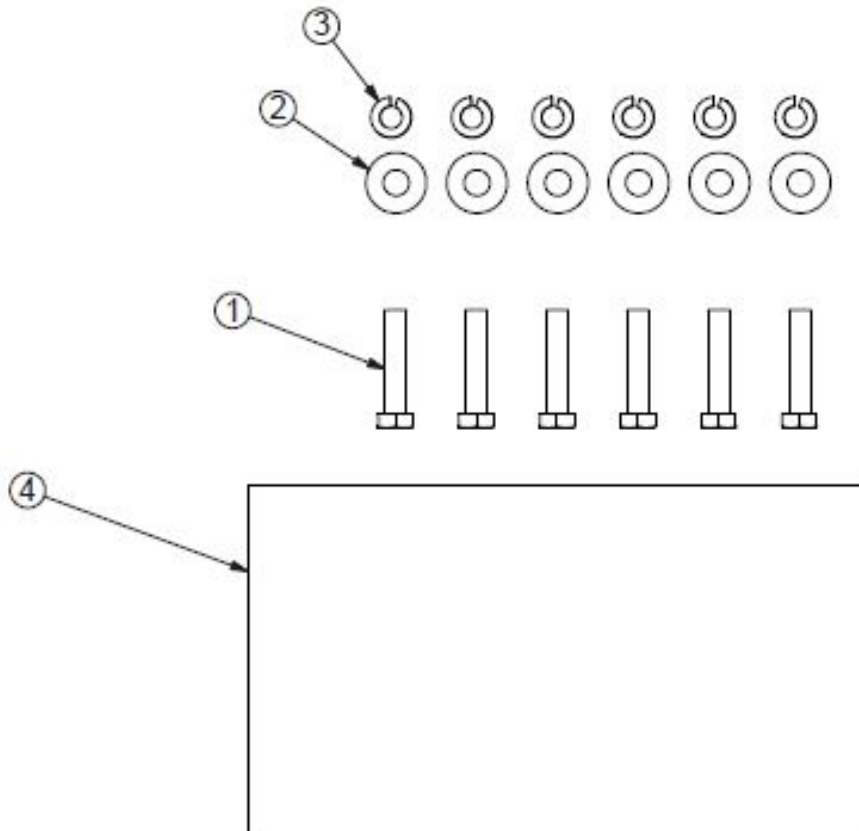

**ASSEMBLY FASTENERS
BAG54106**

ITEM NO.	PART NUMBER	DESCRIPTION	QTY
1	BAG0509-A	6"X10" 4MIL AUTOBAG	1
2	FAS0597	SCREW,HH 5/16-18X1 SST	24
3	FAS0552	WASHER,FLAT,5/16 SST	24
4	FAS0248	NUT,HEX NLK 5/16-18 SS W	24

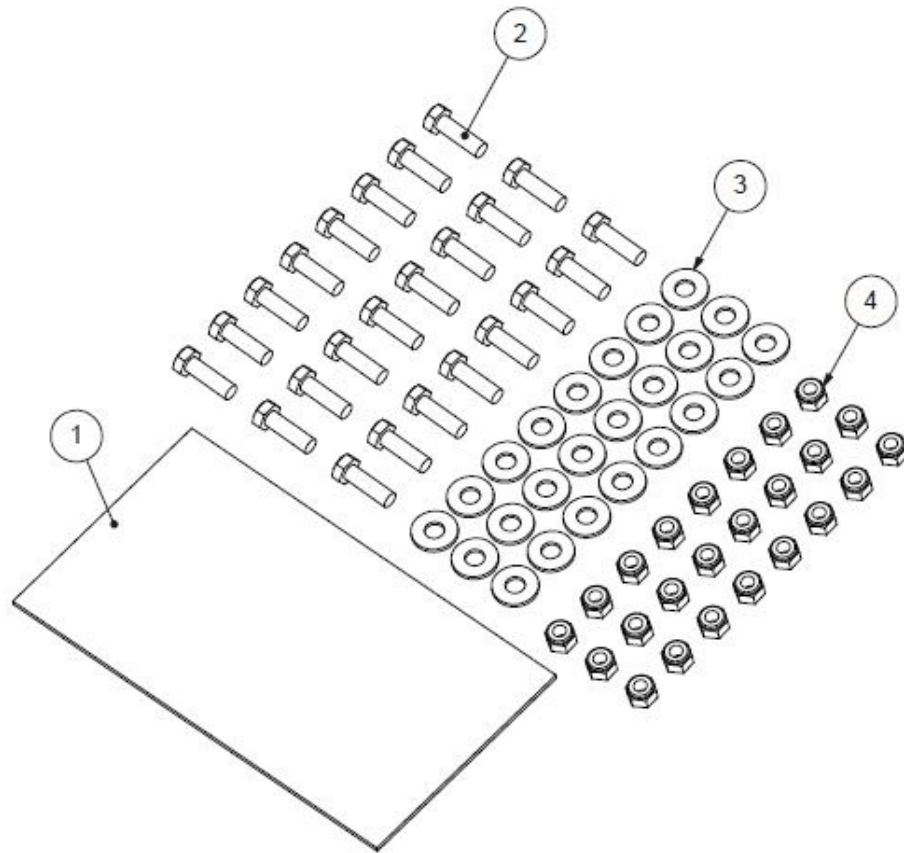

Step 01 Add Teflon Tape to Roof Rails

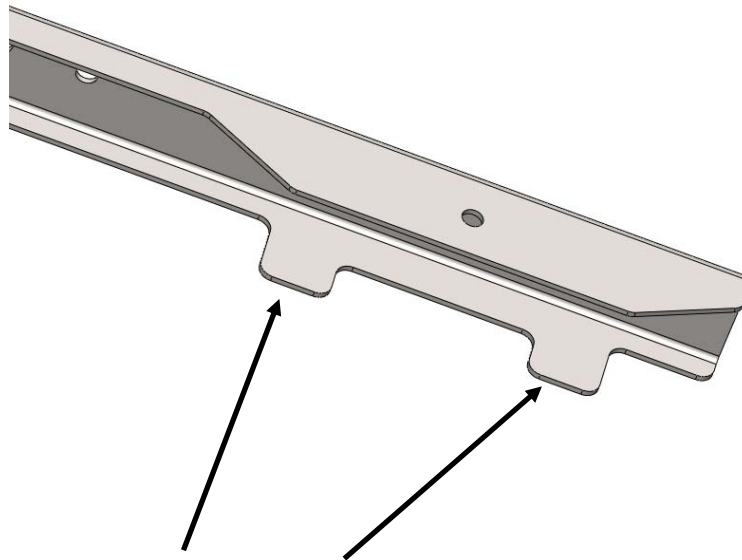

CUT 39317 TEFLON TAPE TO LENGTH TO FIT ALL TABS AS SHOWN AND PLACE ON UNDERSIDE OF THESE TABS TO PREVENT THE OUTER EDGES OF THE TABS FROM CONTACTING THE ROOF SURFACE AND WEARING THRU THE PAINT. 2 TABS AT EACH MOUNTING POINT, BOTH ROOF RAILS.

Step 02 ATTACH ROOF RAILS TO VAN AS SHOWN, 45168-B FOOT CLAMP SLIPS UNDER THE HEAD OF THE ROOF PIN AND THEN LIP SLIDES OVER ROOF RAIL. SCREW IS INSTALLED INTO RIVNUT THRU TOP SURFACE OF RAIL.
IMPORTANT!! HEAD OF PIN MUST LAY BETWEEN VERTICAL WALL AND OFFSET OF FOOT CLAMP AS SHOWN.

REPEAT AT ALL 6 ATTACHMENT POINTS. TORQUE FASTENERS TO 12-15 FT LBS. **AFTER INSTALLING CROSS BOWS.**

54092-B 118" SS (1)
54094-B 136" SS (1)
ROOF RAIL

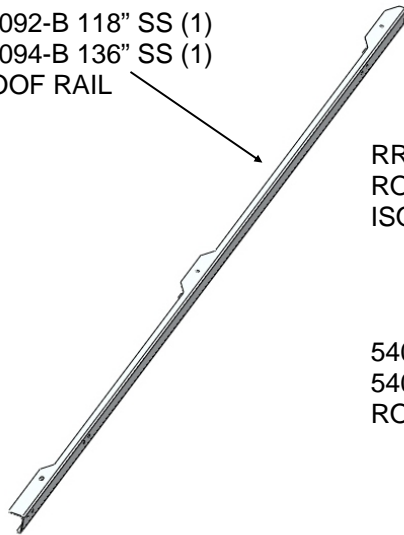

FRONT OF VAN

RRKPM118/RRKPM136
ROOF RAIL KIT. TOP
ISO VIEW

54091-B 118" CS (1)
54093-B 136" CS (1)
ROOF RAIL

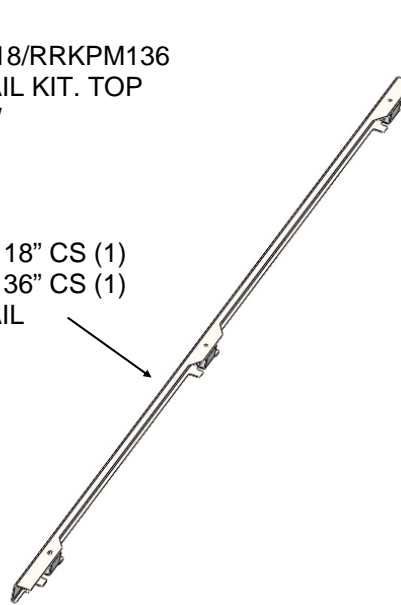

NOTE ANGLE NOTCH ON FRONT EDGE

45168-B CLAMP (6)
FAS0242 5/16-18X1.5 HH (6)
FAS0552 5/16 WASHER (6)
FAS0588 5/16 SPLIT L'WASHER (6)

THIS SIDE TOWARDS SIDE OF VAN

THIS SIDE TOWARDS SIDE OF VAN

PIN AND PLATE PART OF ROOF ASSEMBLY

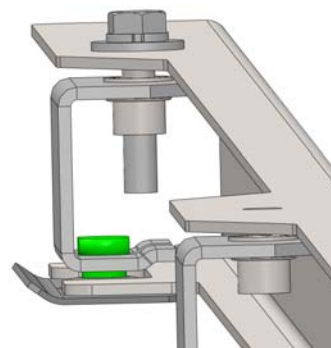
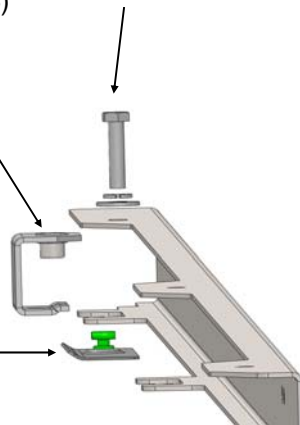

SHOWN ASSEMBLED

Step 03 ASSEMBLE (4) FEET TO (2) CROSSBOWS. DO NOT TIGHTEN FASTENERS AT THIS TIME. AFTER CROSSBOWS ARE ASSEMBLED ONTO THE ROOF RAILS YOU WILL TORQUE FASTENERS TO 10-12 FT LBS.

NOTE: PAY ATTENTION TO ORIENTATION OF THE FEET TO THE CROSSBOWS.

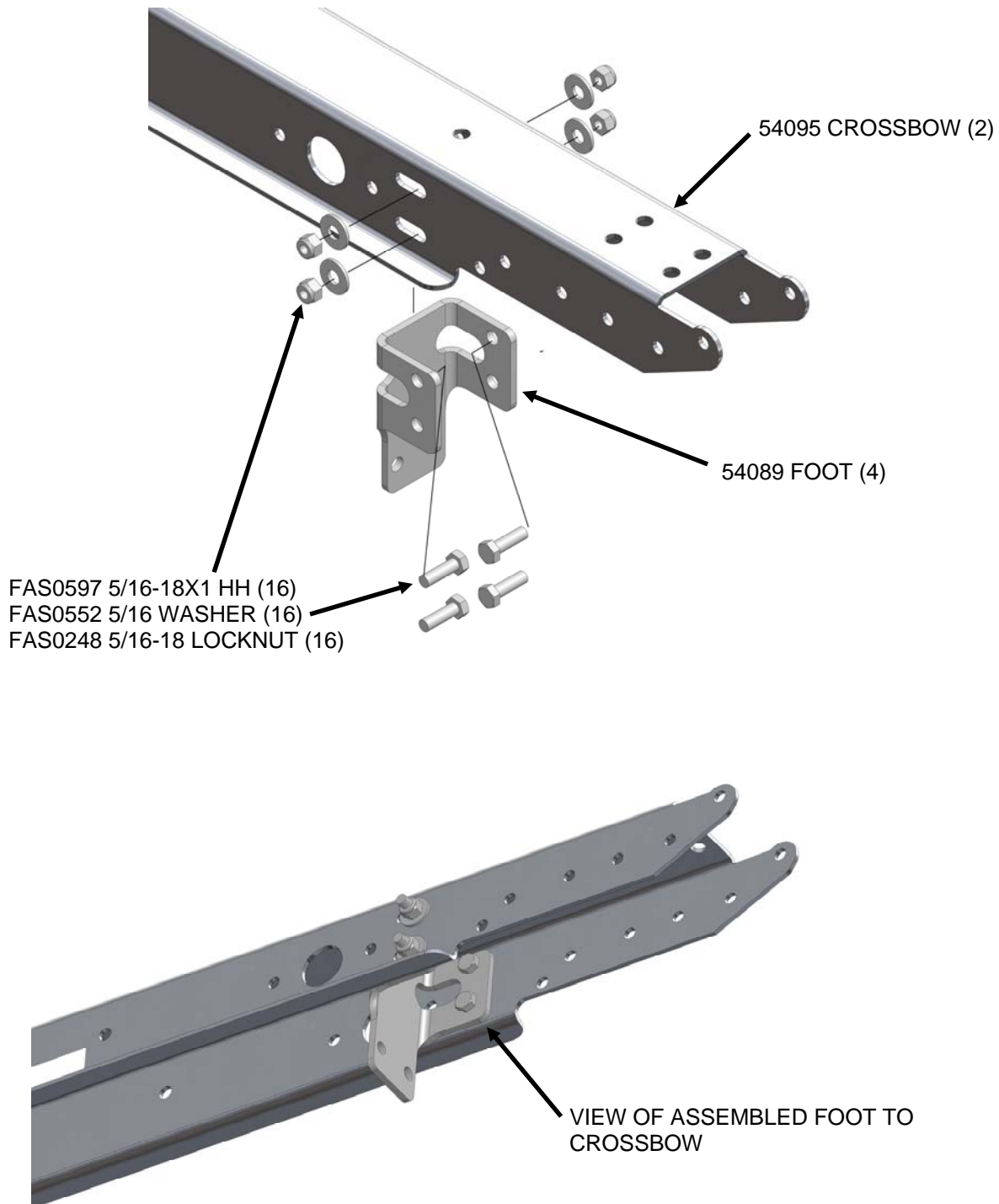

Step 04 ASSEMBLE THE FRONT AND REAR CROSSBOW'S TO THE ROOF RAILS. THE REAR ROOF BOW SHOULD HAVE THE STICKERS FACING THE REAR OF THE VEHICLE, THE FRONT CROSSBOW WILL HAVE THE STICKERS FACING THE FRONT OF THE VEHICLE. TORQUE FASTENERS TO 12-15 FT.LBS.

NOTE: PAY ATTENTION TO ORIENTATION OF THE FEET TO THE ROOF RAILS.

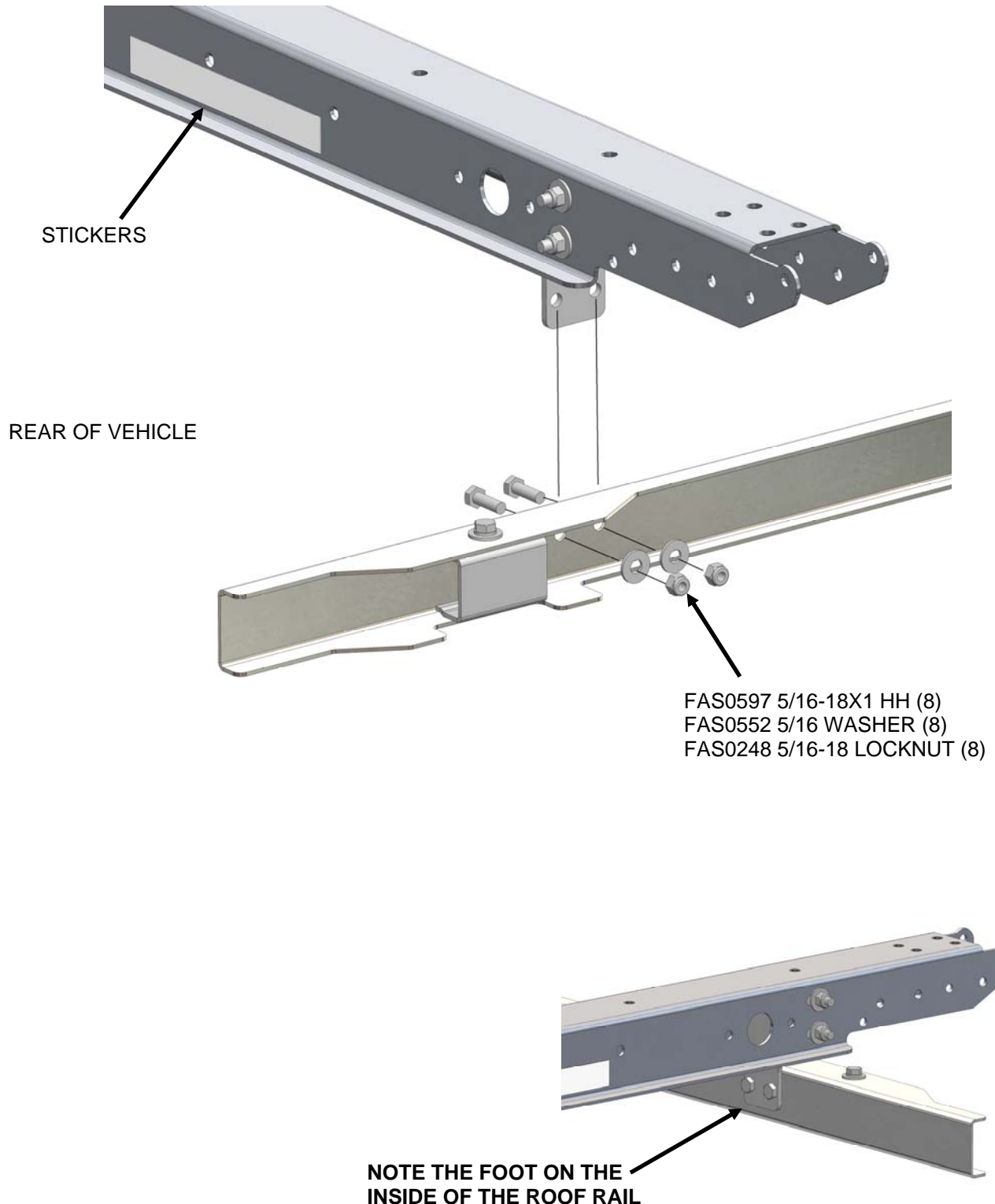

Step 05 YOUR ASSEMBLY SHOULD LOOK LIKE THE IMAGE BELOW



ATTENTION!
LADDER RACK PURCHASER

IT IS ADVISED THAT ALL FASTENERS THAT ASSEMBLE AND INSTALL YOUR LADDER RACK ARE CHECKED FOR TIGHTNESS AT 2 WEEKS OF OPERATION AND THEN RECHECKED AGAIN AT 6 WEEKS OF OPERATION.

ASSEMBLY FASTENERS COULD LOOSEN DURING USE DUE TO VIBRATION THROUGH YOUR VEHICLE WHILE ON THE ROAD OR IN AND OUT OF CONSTRUCTION SITES.

THIS IS A PREVENTATIVE MAINTENANCE STEP TO INSURE YOUR LADDER RACK GIVES YOU A LONG SERVICE LIFE.

**INSTALLER: PLEASE PRESENT THIS STATEMENT TO THE END USER WHEN DELIVERING THE INSTALLED PRODUCT!