

## 80-2LR Conduit Carrier Kit

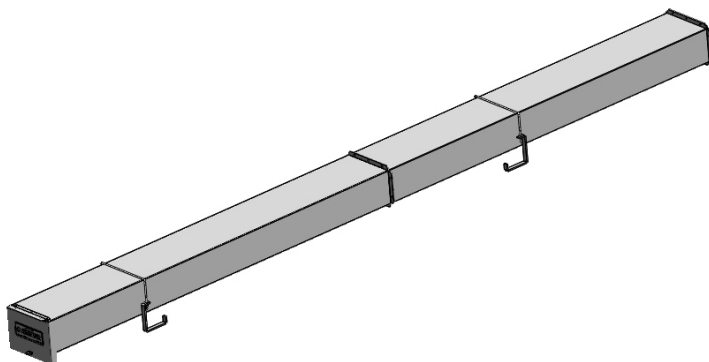

PRODUCT WEIGHT  
**38 LBS**

WIDTH x DEPTH x HEIGHT  
**10" X 6" X 150"**

CAPACITY  
**12 Foot Conduit**

COLOR  
**Aluminum**

CATALOG NUMBER  
**80-2LR**

### PRODUCT FEATURES

**This Conduit kit adapts to the next generation ladder rack.**

**Features include, a two piece bolt together construction; bolt on front clean out plate; Pad lockable swivel hasp; universal no drill mounting bracket; all stainless steel mounting hardware.**

**NOTE: WILL NOT WORK ON THE ORIGINAL GM FSV LADDER REACKS (DDL63GM, DDL64GM, 63-GLGM, 64-GLGM ) OR IF YOU HAVE THE STEP LADDER KIT ADD ON (GLSLK OR GLSLKGM ).**

**SEE PAGE 2 FOR APPLICATION NOTES AND ACCESSORIES, OTHER PRODUCTS THAT WORK WITH THIS UNIT.**



**CATALOG NUMBER 80-2LR**

**PRODUCT APPLICATION**

**This Conduit kit adapts to the roof rail kit, all except the ORIGINAL GM FSV LADDER RACK.**

**ACCESSORIES THAT WILL WORK WITH THIS PRODUCT**

<b>CATALOG NUMBER</b>	<b>DESCRIPTION</b>
DDLR61FTL	Single Drop-Down Ladder Rack, Ford Transit Low Roof
DDLR63FTL	Double Drop-Down Ladder Rack, Ford Transit Low Roof
DDLR64FTL2	Drop-Down Ladder Rack Combo, Ford Transit Low Roof
DDLR61FTM	Single Drop-Down Ladder Rack, Ford Transit Mid Roof
DDLR63FTM	Double Drop-Down Ladder Rack, Ford Transit Mid Roof
DDLR61NVL	Single Drop-Down Ladder Rack, Nissan Low Roof
DDLR63NVL	Double Drop-Down Ladder Rack, Nissan Low Roof
DDLR64NVL2	Drop-Down Ladder Rack Combo, Nissan Low Roof
DDLR61GM2	Single Drop-Down Ladder Rack, GM FSV
DDLR63GM2	Double Drop-Down Ladder Rack, GM FSV
DDLR64GM2	Drop-Down Ladder Rack Combo, GM FSV
61-GLFTL2	G/L Ladder Rack, Transit Low Roof
63-GLFTL2	G/L Ladder Rack, Double, Transit Low Roof
61-GLGM2	G/L Ladder Rack, GM FSV
63-GLGM2	G/L Ladder Rack, Double, GM FSV
61-GLNVL2	G/L Ladder Rack, Nissan Low Roof
63-GLNVL2	G/L Ladder Rack, Double, Nissan Low Roof

**SPECIAL APPLICATION NOTES**

**Only 1 conduit kit can be installed per product noted above. For ease of installation, install the conduit mtg bracket to cross bars prior to installing cross bars to roof of vehicle.**

**Introduction / Comments:**

THIS CONDUIT KIT IS DESIGNED TO ADAPT TO THE CROSS BOWS ON THE NEW LADDER RACKS.

**Note:**

It is advised that all fasteners used in this assembly and installation of this Rack should be checked for tightness at the following intervals: @ 2-weeks and again @ 6-weeks of operation. This preventive maintenance step must be completed to ensure your package gives you long service life.

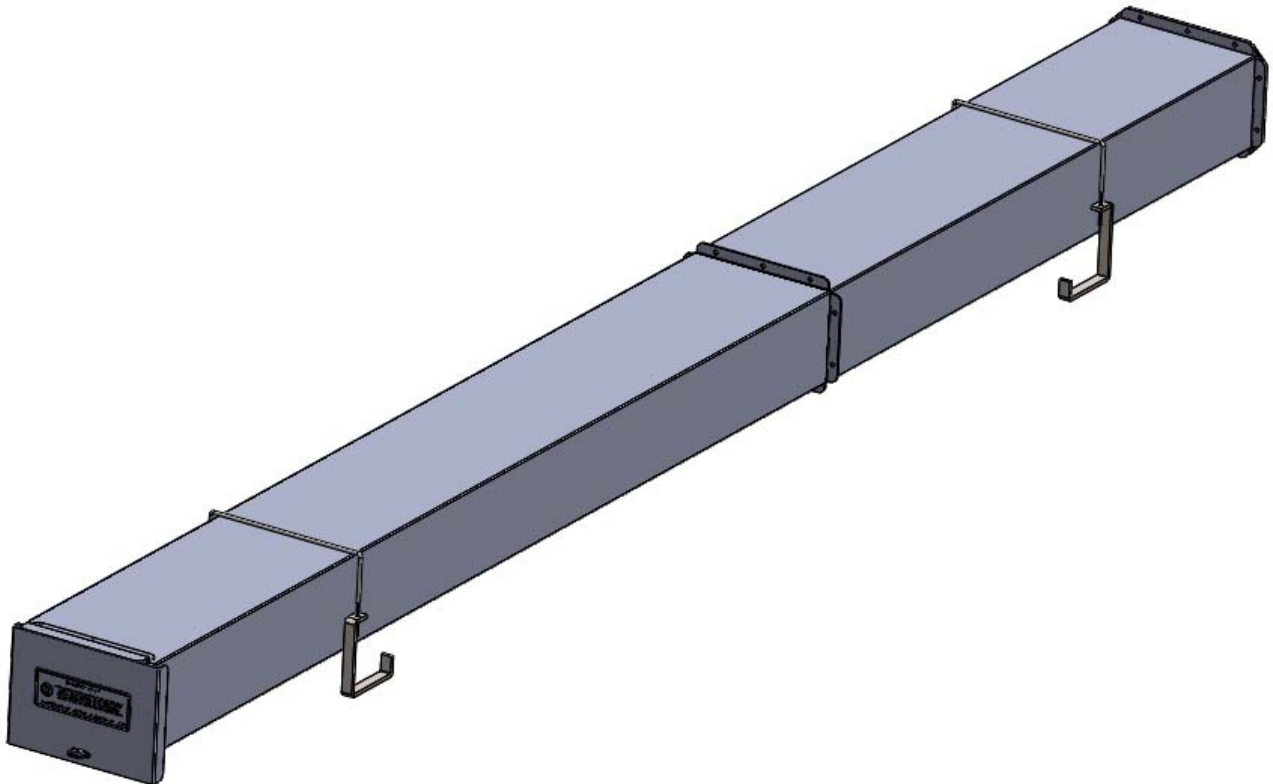

**80-1LR / 80-2LR  
ALUMINUM CONDUIT KIT**

## - PRECAUTIONS -



**CAUTION**  
THE USE OF AIR IMPACT TOOLS CAN OVER-TORQUE FASTENERS AND CAUSE FASTENER FAILURE!



**CAUTION**  
ALL INSTALLATION HOLES SHOULD BE SEALED WITH SILICON OR BUTYL SEALANT TO PREVENT EXHAUST FUMES FROM ENTERING THE VEHICLE!



**DANGER**  
INSPECT FOR FUEL TANK, FUEL LINES, BRAKE LINES, HIGH VOLTAGE BATTERIES AND ELECTRICAL LINES PRIOR TO DRILLING TO AVOID DAMAGING CRITICAL VEHICLE SYSTEMS OR INJURY TO INSTALLER DURING INSTALLATION PROCESS!



**CAUTION**  
TO AVOID DAMAGING THE VEHICLE ALWAYS USE DRILL STOPS WHEN DRILLING ANY INSTALLATION HOLES!  
ADRIAN AVAILABLE PART #'S 31121-0 (3/8" X 1/2" DEEP), 31121-0 (1/2" x 1/2" DEEP)



## - IMPORTANT WARRANTY REQUIREMENTS -

1. SUBSTITUTING ADRIAN STEEL SPECIFIED FASTENERS FOR ASSEMBLY AND/OR INSTALLATION WILL VOID YOUR PRODUCT WARRANTY.
2. ALL HOLES DRILLED INTO VEHICLE SHOULD HAVE THE RAW METAL EDGES SEALED WITH A SELF-ETCHING PRIMER TO RESIST CORROSION AND POTENTIAL FASTENER POINT FAILURE.
3. ALL FASTENERS USED IN THE INSTALLATION OF THIS PRODUCT SHOULD BE TIGHTENED TO THE TORQUE(S) SPECIFIED IN THESE INSTRUCTIONS.
4. THESE INSTRUCTIONS SHOULD BE KEPT WITH THE VEHICLE.

### THE BASIC TOOLS NEEDED FOR MOST INSTALLATIONS



DRILL



DRILL BIT WITH STOP



RATCHET, SOCKETS AND/OR WRENCHES



SCREWDRIVERS



MEASURING TAPE

ADDITIONAL TOOLS MAY BE NEEDED FOR THIS INSTALLATION AND THEY WILL BE IDENTIFIED IN THE STEPS THAT FOLLOW.

If your vehicle contains carpet or a rubber floor mat you will need to prepare the mounting location. Position the product to be installed into the vehicle and once you are satisfied with the mounting locations, mark the mounting locations. Using a 1-3/16" diameter carpet cutter (P/N: 31183-0). Select the appropriate floor spacers as shown in the illustration. Set those aside for use later into the installation process. Using the correct drill bit size for the selected plusnut, drill the mounting holes in the vehicle sheet metal to prepare for installing the plusnuts. If you are thru-bolting at any of the locations simply drill a hole that is 1/16" larger than the bolt size(s) for those locations. Once you have drilled the holes into the vehicle, the raw metal edges should be sealed using a self-etching primer to resist corrosion and potential fastener point failure.

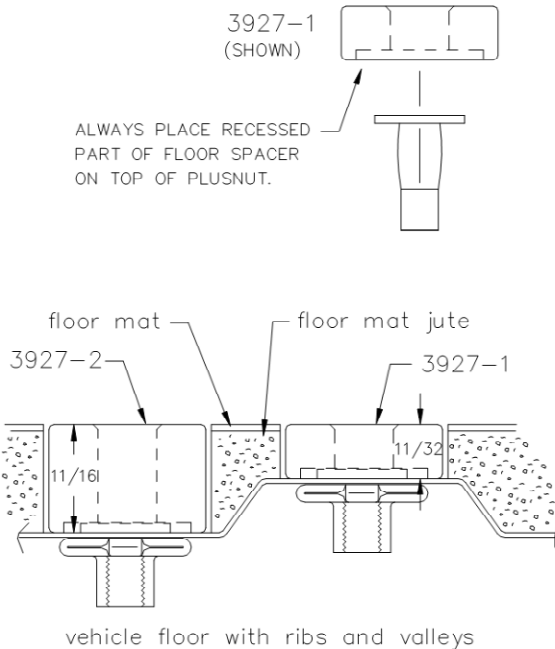

A PLUSNUT (RIVNUT) SETTING TOOL IS REQUIRED FOR PLUSNUT (RIVNUT) INSTALLATION . PLUS NUT SETTING TOOL CAN BE ORDERED THROUGH ADRIAN STEEL, OR USE AN AIR POWERED PLUSNUT SETTING GUN.

1/4-20UNC Plusnut (FAS0052) Use 3/8" dia. drill w/stop  
 FAS0080 SCREW, HXHD, 1/4-20UNCx2.00", G8  
 FAS0067 WASHER, FLAT, 1/4"ID  
 22200-0 PLUSNUT TOOL

5/16-18UNC Plusnut (FAS0091) Use 1/2" dia. drill w/stop  
 FAS0095 SCREW, HXHD, 5/16-18UNCx2.00", G8  
 FAS0086 WASHER, FLAT, 5/16"ID  
 22200-0 PLUSNUT TOOL

Place barrel of the plusnut body in sheet metal thru hole until flange is flush with sheet metal.  
 Using a 9/16" combination wrench of plusnut tool body and a second hand wrench, ratchet, or air tool, rotate the hex bolt head CW to draw plus nut flanges up (set the plusnut).

BAG20934-0 - FASTENER BAG, CONDUIT KIT

ITEM NO.	PART NUMBER	DESCRIPTION	QTY.
1	BAG0507-A	5" x 7" 3MIL AUTOBAG	1
2	FAS0125	Nut, Nylon Insert Lock, 1/4-20 SST	14
3	FAS0234	Washer, Flat, 1/4, SST	24
4	FAS0548	Screw, Hex Hd, 1/4-20x.75, Stainless Steel	14
5	16101-0	.125x.75 Foam Tape	1
6	26618-0	Silicone Sealant	1

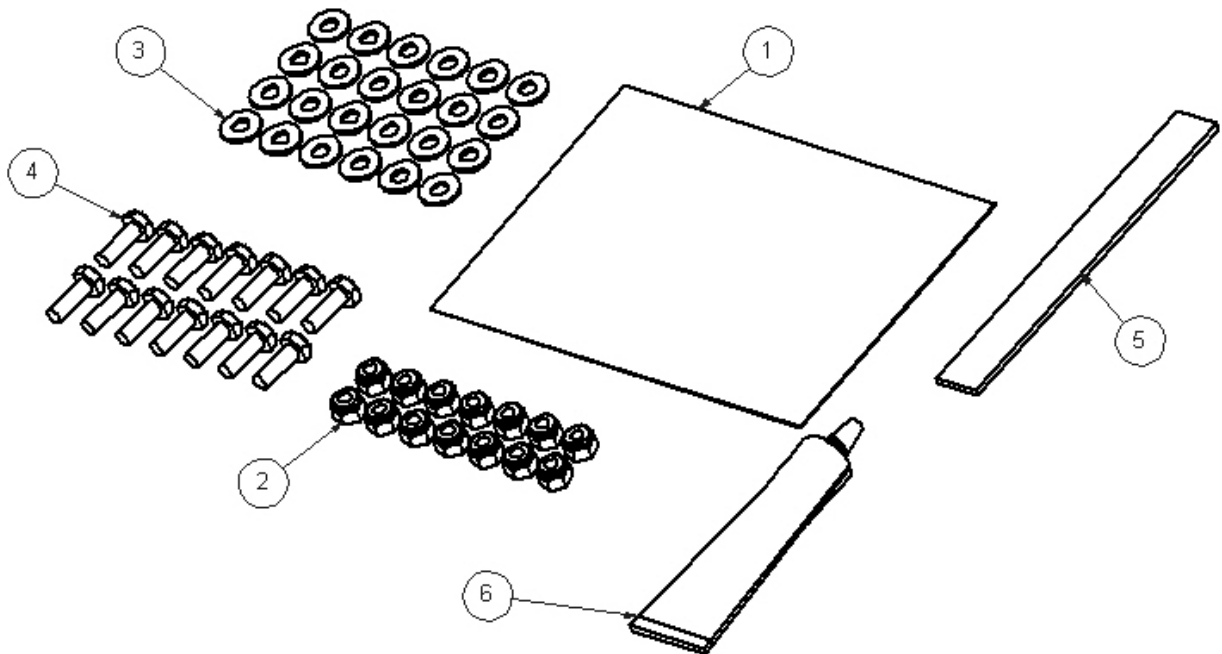

**STEP #1 : ADD FOAM TAPE TO THE LID**

TURN FRONT SECTION W/ LID UPSIDE DOWN AND ADD FOAM TAPE

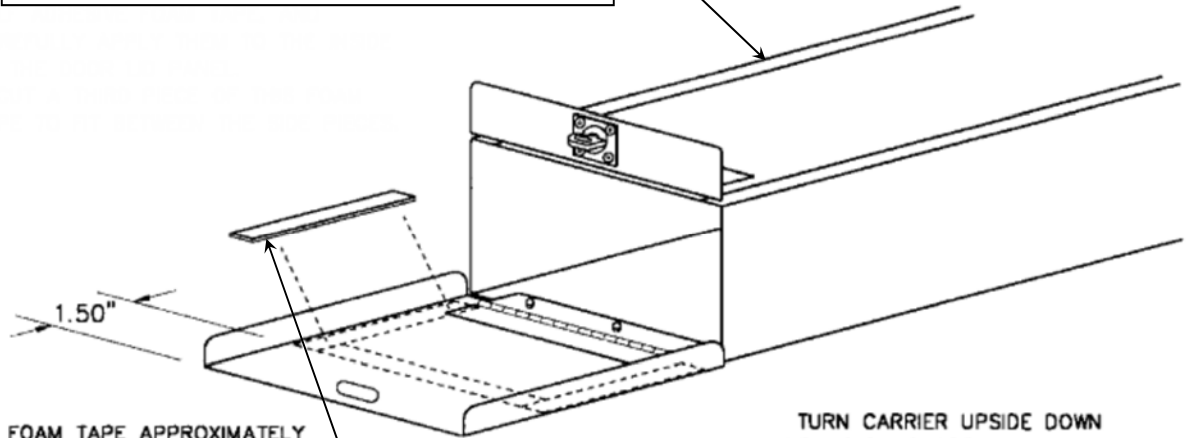

KEEP FOAM TAPE APPROXIMATELY 1.50" FROM DOOR EDGE.

TURN CARRIER UPSIDE DOWN AND HOLD LID OPEN.

16110-0—CUT TO 6" LG (2) PLACES  
CUT TO 10" (1) PLACE

**STEP #2 : ASSEMBLE CONDUIT KIT**

PRE-ASSEMBLED REAR SECTION WITH BACK

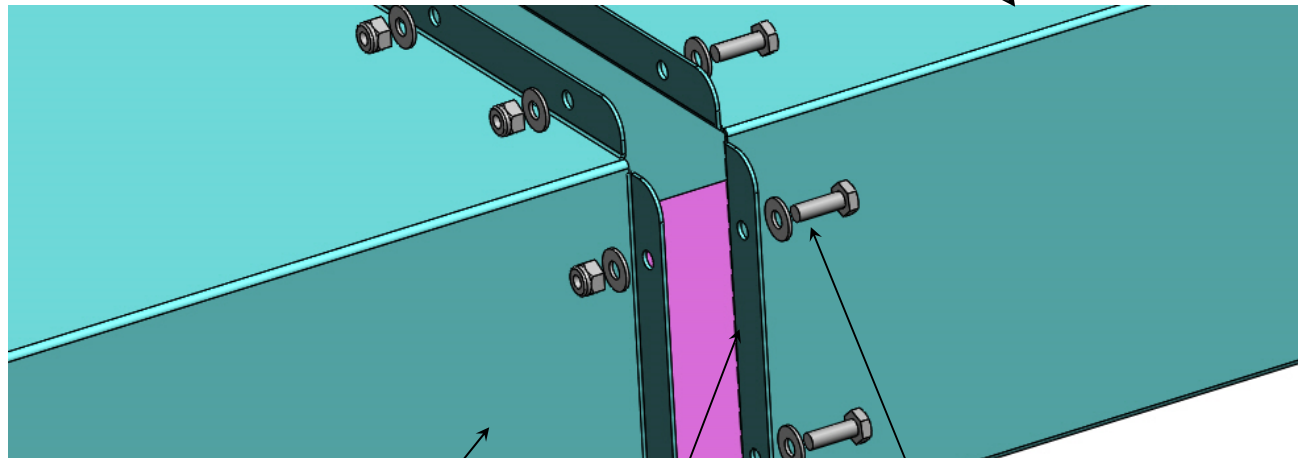

PRE-ASSEMBLED FRONT SECTION WITH LID

26618-0 SILICONE ALL AROUND FLANGE

FAS0548 (10)  
FAS0234 (20)  
FAS0125 (10)

**STEP #3 : POSITION CONDUIT CARRIER ON THE LADDER RACK.**

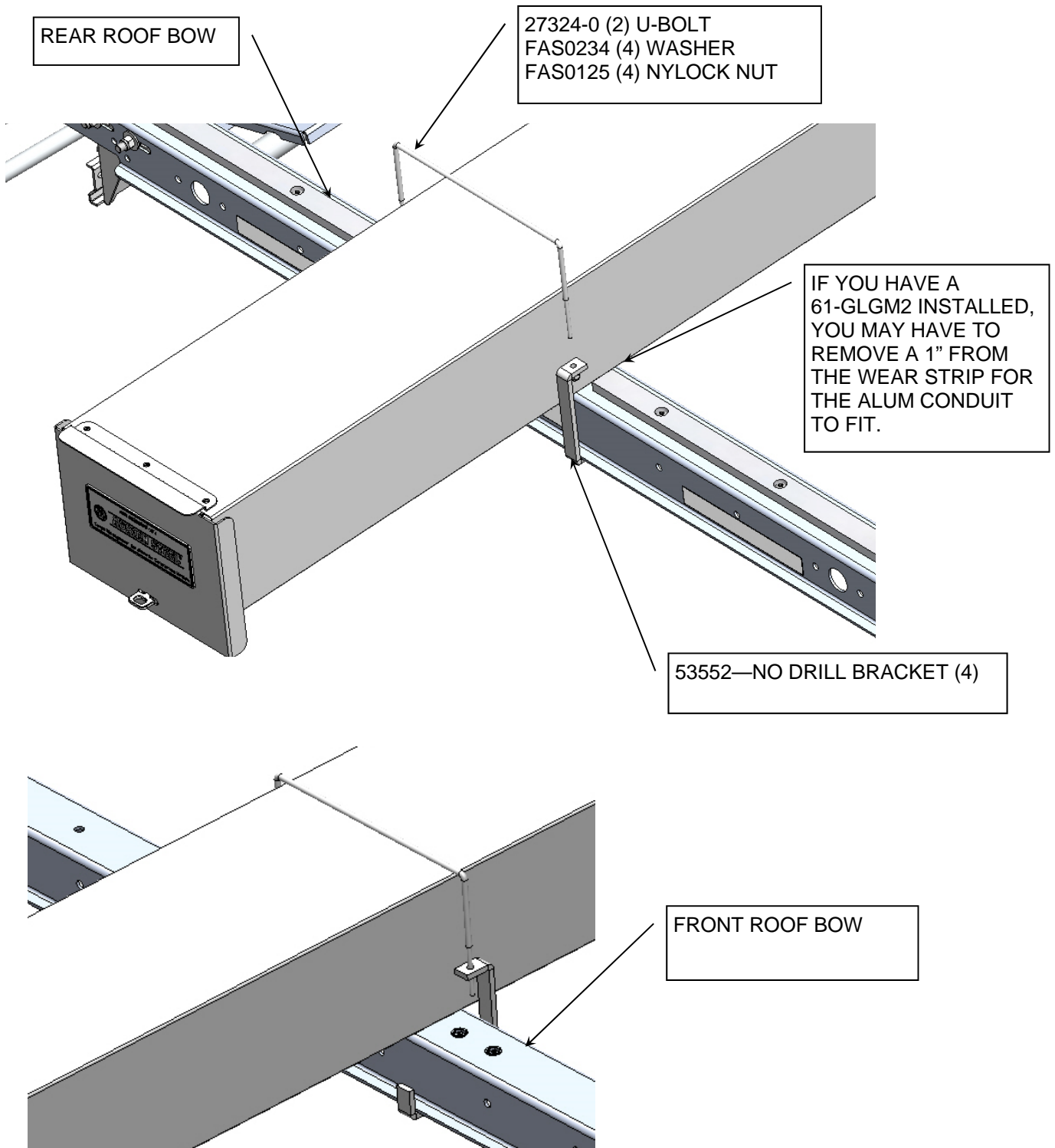

**DOUBLE CHECK ALL FASTENERS LOCATIONS TO BE SURE THAT ALL FASTENERS ARE TIGHTENED TO SPECIFICATIONS.  
YOUR INSTALLATION IS NOW COMPLETE!  
STOW THIS COPY IN THE VEHICLE FOR FUTURE REFERENCES!**