

INSTR. : 69485
NUMBER

PG: 1
REV: A

PART .Max Drop ProLift
NUMBER •High Roof

PART •ProLift Adjustment Instructions -
DESC. •High Roof Vans

Step 3: With 1/2" Socket loosen
nut, slide post so that it is snug
against ladder.
Tighten nut

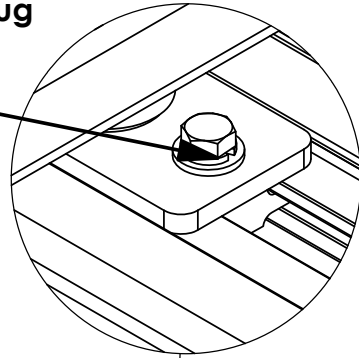

Step 1: Make sure clamp
is roughly 1/8" from end
of secondary drop
If not loosen nuts (X2)
with 1/2" socket and
slide so it is within 1/8".
Tighten Nuts (X2)

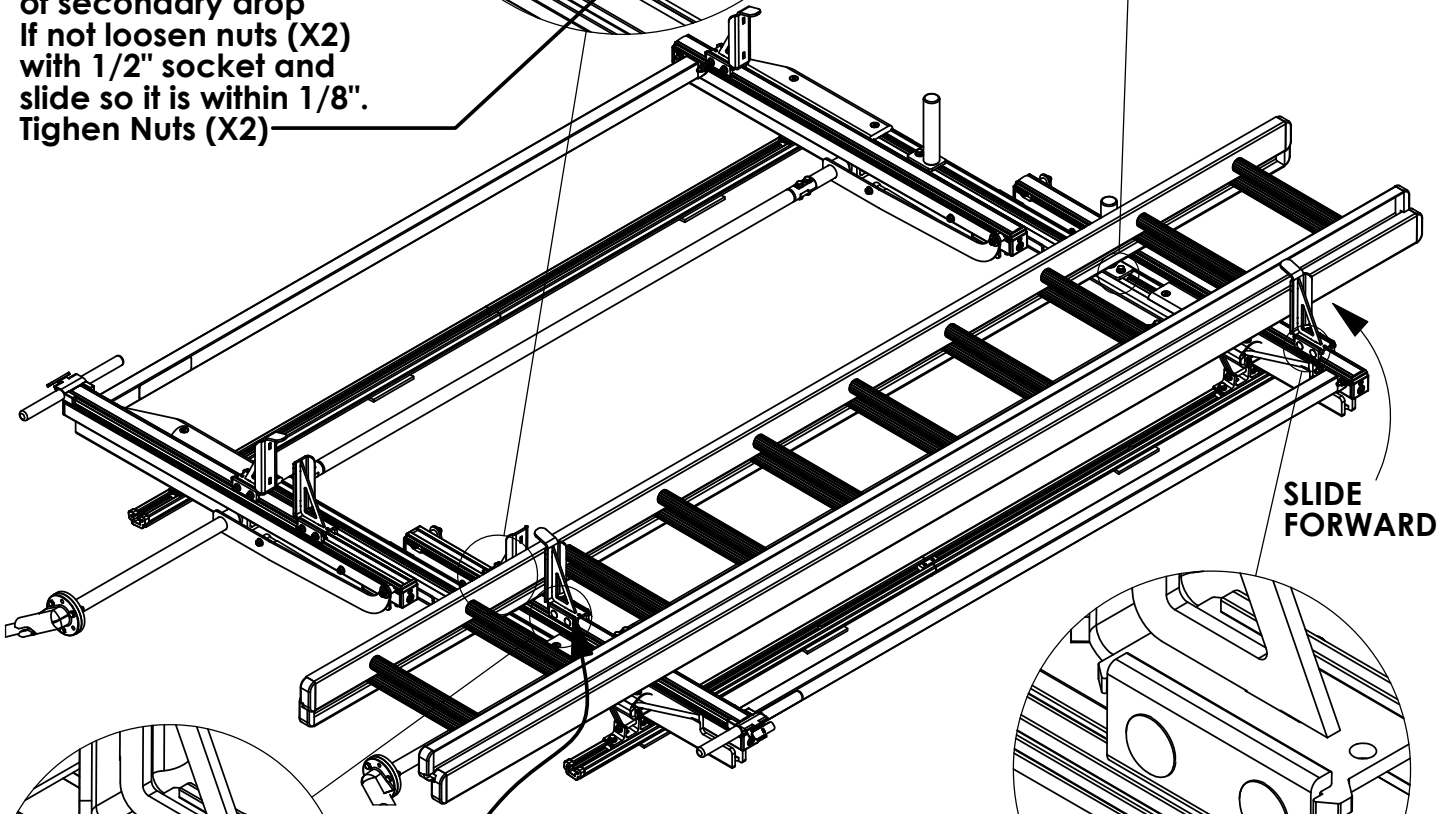
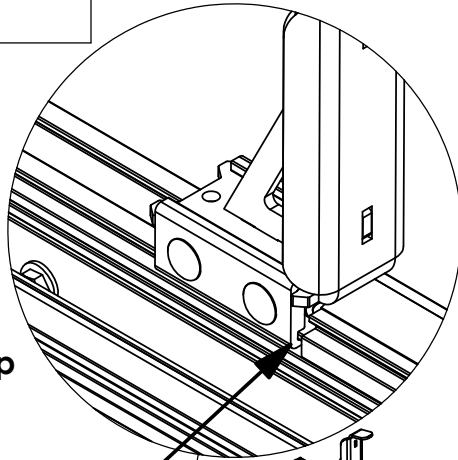

SLIDE
FORWARD

SLIDE
FORWARD

Step 4: With 1/2" Socket loosen
nuts (X2), slide clamp so that it is
snug against ladder.
Tighten nuts (X2).

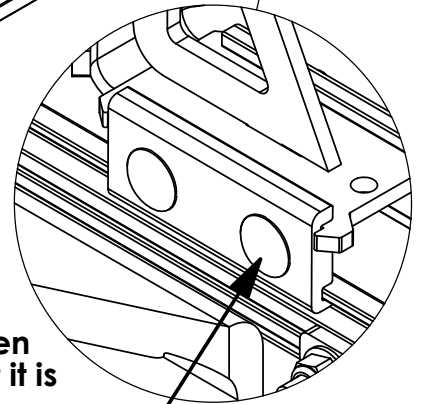

Step 2: With 1/2" Socket loosen
nuts (X2), slide clamp so that it is
snug against ladder.
Tighten nuts (X2).

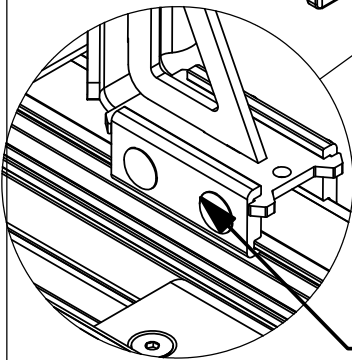

Once all brackets are adjusted operate rack to make sure clamps are not too tight

INSTR. NUMBER : 68627	PG: 1	REV: B	ITEM NO.	PART NUMBER	DESCRIPTION	QTY.
	PART NUMBER • PLMDPSH PART NUMBER • PLMDDSH		1	68400-W	PROLIFT,HR,DROP ASM,PS,RR, WHITE	1
2			68399-W	PROLIFT,HR,DROP ASM,PS,FR, WHITE	1	
PART • PROLIFT,MAX,PS,HR DESC. • PROLIFT,MAX,DS,HR		3	66959-W	DROP DOWN OUTER BAR, WELDMENT, WHITE	1	
		4	66572-B	DROP DOWN, CS CENTER DRIVELINE, BLK	1	
		5	48265	DAMPER ASSEMBLY	1	
		6	58239	COMPRESSION DAMPER	1	
		7	56330	HANDLE ASM, DDLR, HR	1	
		8	68037-B	CLAMP PAD, 6.5", BLACK	2	
		9	68458-B	PROLIFT,HR,INNER CLAMP,B	1	
		10	68186-W	PROLIFT INNER POST, WHITE	1	
		11	68628-W	PROLIFT,HR,DAMPER BRKT, W	2	

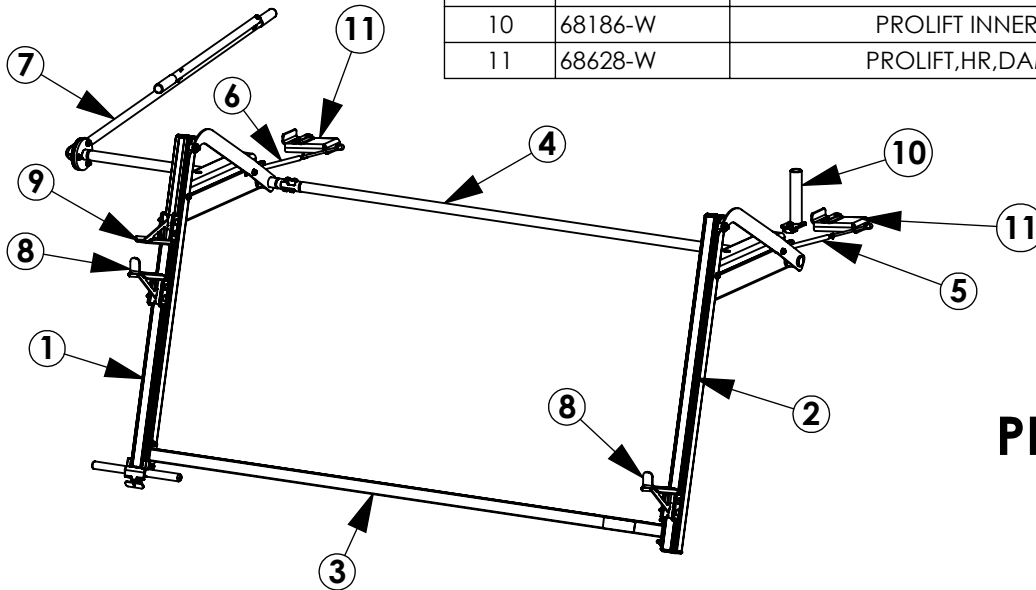

PLMDPSHW

ITEM NO.	PART NUMBER	DESCRIPTION	QTY.
1	68402-W	PROLIFT,HR,DROP ASM,DS,RR, WHITE	1
2	68401-W	PROLIFT,HR,DROP ASM,DS,FR, WHITE	1
3	66959-W	DROP DOWN OUTER BAR, WELDMENT, WHITE	1
4	66563-B	DROP DOWN, SS CENTER DRIVELINE, BLK	1
5	48265	DAMPER ASSEMBLY	1
6	58239	COMPRESSION DAMPER	1
7	56330	HANDLE ASM, DDLR, HR	1
8	68037-B	CLAMP PAD, 6.5", BLACK	2
9	68458-B	PROLIFT,HR,INNER CLAMP,B	1
10	68186-W	PROLIFT INNER POST, WHITE	1
11	68628-W	PROLIFT,HR,DAMPER BRKT, W	2

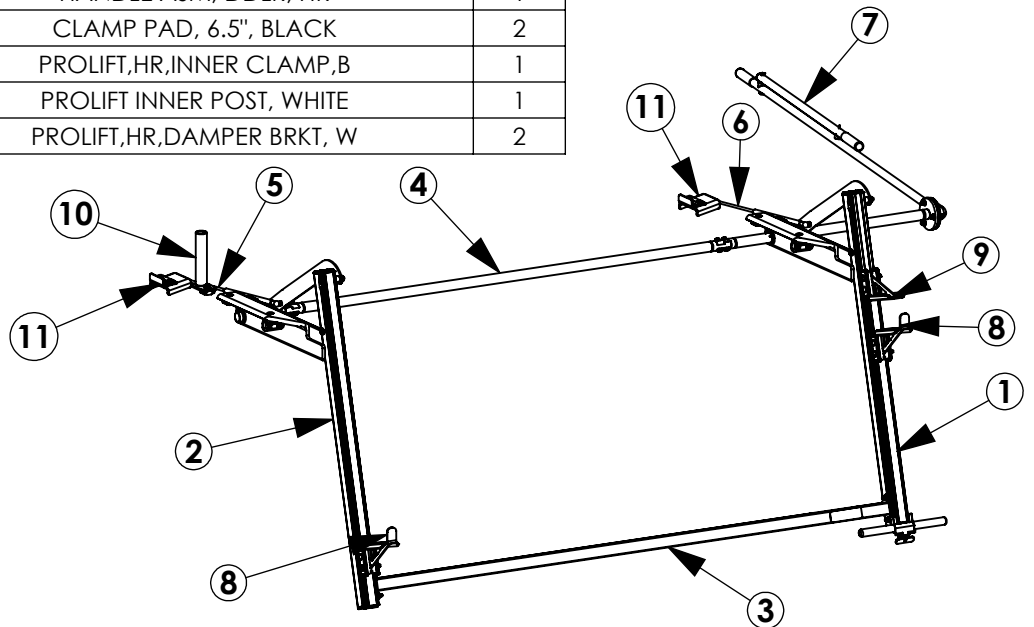

PLMDDSHW

GET TO KNOW THE VEHICLE - AT THE BEGINNING OF ANY INSTALLATION, CHECK THE LOCATION OF THE FUEL TANK, FUEL LINES, BRAKE LINES, HIGH VOLTAGE BATTERIES AND WIRING HARNESSSES TO AVOID INJURY OR PROPERTY DAMAGE FROM TOOL CONTACT.

SEAL ALL EXTERIOR HOLES - ALL INSTALLATION HOLES SHOULD BE SEALED WITH BUTYL TAPE OR SILICON TO PREVENT WATER AND EXHAUST GASES FROM ENTERING THE VEHICLE.

CONTROL DRILL DEPTH - TO AVOID DAMAGE TO THE VEHICLE, USE A DRILL STOP OR CLEARED STEP BIT WHEN DRILLING INSTALLATION HOLES.

ALWAYS ADD PRIMER - WHEN ADDING INSTALLATION HOLES BE SURE TO USE A SELF-ETCHING PRIMER TO PREVENT CORROSION, FASTENER FAILURE AND INJURY.

MOUNTING POINTS MUST HAVE METAL-TO-METAL CONTACT - USE PROVIDED MOUNTING SPACERS TO ACCOMMODATE FOR VEHICLE FEATURES, CARPET OR SUBFLOORS.

PROVIDE CLEARANCE FOR SPACERS - IF THE INSTALLATION VEHICLE CONTAINS A CARPET OR SUBFLOOR, USE A 1-3/16" DIAMETER CARPET CUTTER (P/N: 31183-0) AT ALL MOUNTING LOCATIONS TO OPEN UP ROOM FOR SPACERS.

CHECK SPACER ORIENTATION - BE SURE THAT THE INDENT IN THE SPACER COVERS THE PLUSNUT HEAD; THIS ENSURES THE MOST METAL-TO-METAL CONTACT AND REDUCES VIBRATION.

PLUSNUT INSTALLATION - A PLUSNUT GUN IS RECOMMENDED FOR PLUSNUT INSTALLATION FOR ITS PRODUCTION SPEED. HOWEVER, A PLUSNUT SETTING TOOL CAN ALSO BE USED (P/N: 22200-0).

THRU-BOLT CLEARANCE - WHEN USING A THRU-BOLT AT ANY MOUNTING LOCATION, BE SURE THAT YOUR HOLE HAS 1/16" CLEARANCE.

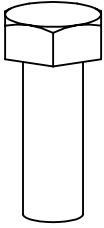
FASTENERS USED

FAS0283
SCREW, HH
5/16-18X.875
QTY: 1

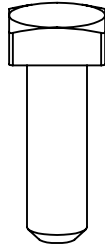

FAS0035
BOLT, SQ HD
5/16-18X1.0
QTY: 4

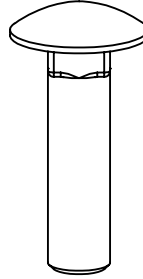

FAS0812
BOLT, CRG
5/16-18X1.25
QTY: 4

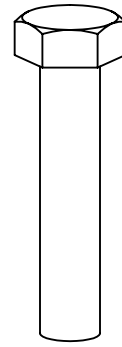

FAS0242
SCREW, HH
5/16-18X1.5
QTY: 4

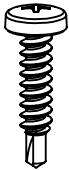

FAS0782
SCREW, THP TEK
#8X.75
QTY: 3

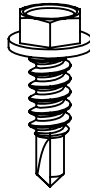

FAS0473
SCREW, HH TEK
#12X.75
QTY: 4

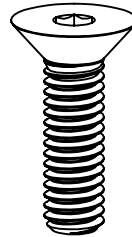

FAS0856
SCREW, FHH
5/16-18X1.125
QTY: 4

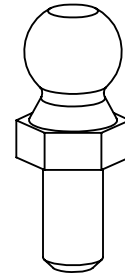

34927-0
SCREW, FHH
5/16-18X1.125
QTY: 2



FAS0552
WASHER, FLAT
USS 5/16
QTY: 5



FAS0588
WASHER, LCK
SPLIT 5/16
QTY: 1



FAS0857
WASHER, LCK EXT
CS 5/16
QTY: 4

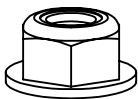

FAS0861
NUT, HEX NLK
FLG 5/16-18
QTY: 20

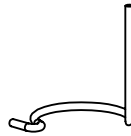

34928-0
CLIP, SPRING,
RETAINER 13MM
QTY: 4

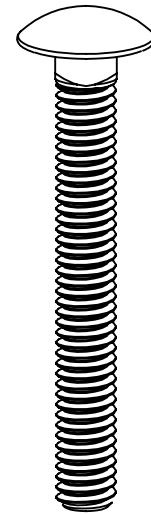

FAS0838
BOLT, CRG
5/16-18X2.5
QTY: 6

HARDWARE USED

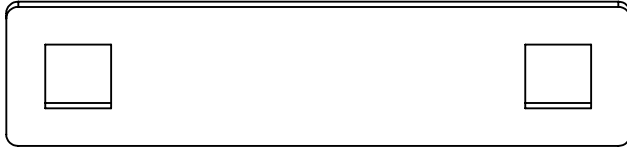

**64830
REAR ROLLER,
BOLT PLATE
QTY: 2**

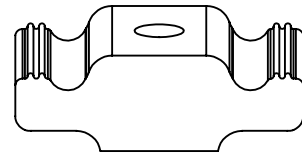

**63490
RAIL SLIDE,
1"
QTY: 5**

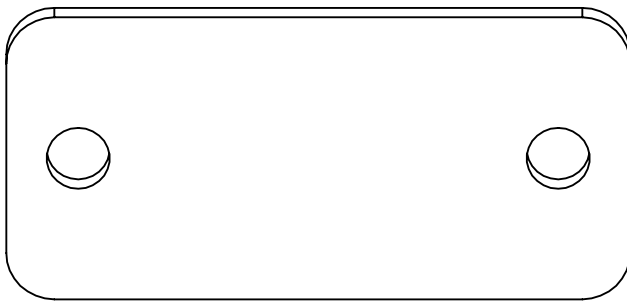

**64831
REAR ROLLER,
SPACER
QTY: 2**

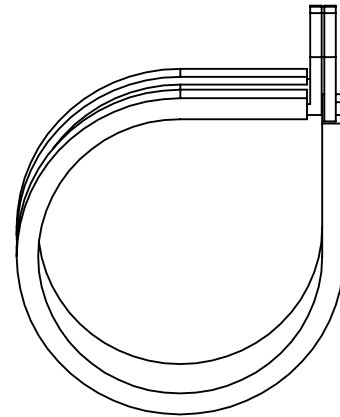

**34921-0
CLAMP, CABLE
1-1/2"
QTY: 1**

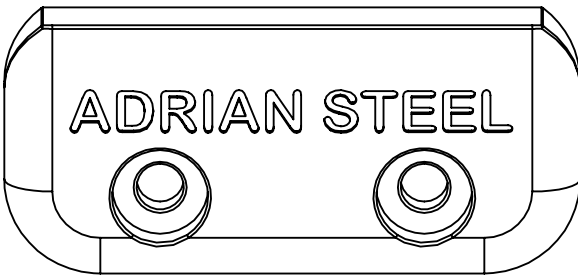

**65961
DROP DOWN
END CAP
QTY: 2**

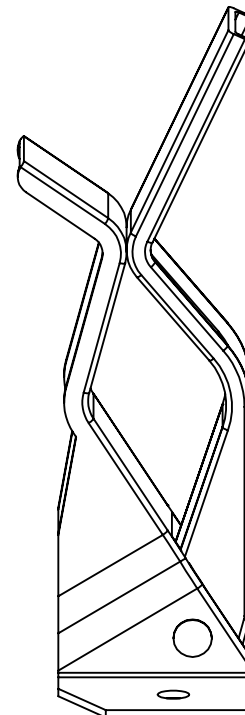

**34922-0
HOLDER, TOOL
QTY: 1**

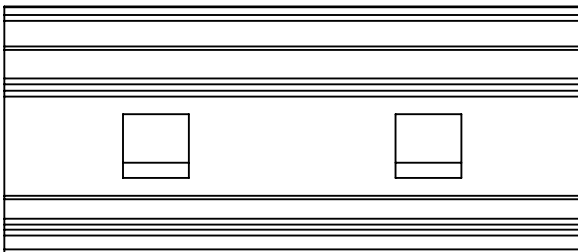

**65963-W
STOP CLAMP
QTY: 6**

BEGIN ASSEMBLY

STEP 1 - INSTALL CLAMPS AND HARDWARE ON DROP DOWN CARTRIDGES

PASSENGER SIDE CARTRIDGES

REAR SUB-ASSEMBLY

FRONT SUB-ASSEMBLY

LOOSELY INSTALL
FAS0856, FAS0857,
& 63490
(4 PLACES)

LOCATION IS APPROXIMATE
AND WILL BE ADJUSTED LATER

FAS0035
SLIDE INTO SLOT
(4 PLACES)

FAS0838, FAS0861
(6 PLACES)
1/2" SOCKET

NOTE ORIENTATION:
SMALLER CHANNEL ON
BOTTOM

DRIVER SIDE CARTRIDGES

REAR SUB-ASSEMBLY

LOCATION IS APPROXIMATE
AND WILL BE ADJUSTED LATER

LOOSELY INSTALL
FAS0856, FAS0857,
& 63490
(4 PLACES)

FAS0035
SLIDE INTO SLOT
(4 PLACES)

FAS0838, FAS0861
(6 PLACES)
1/2" SOCKET

FRONT SUB-ASSEMBLY

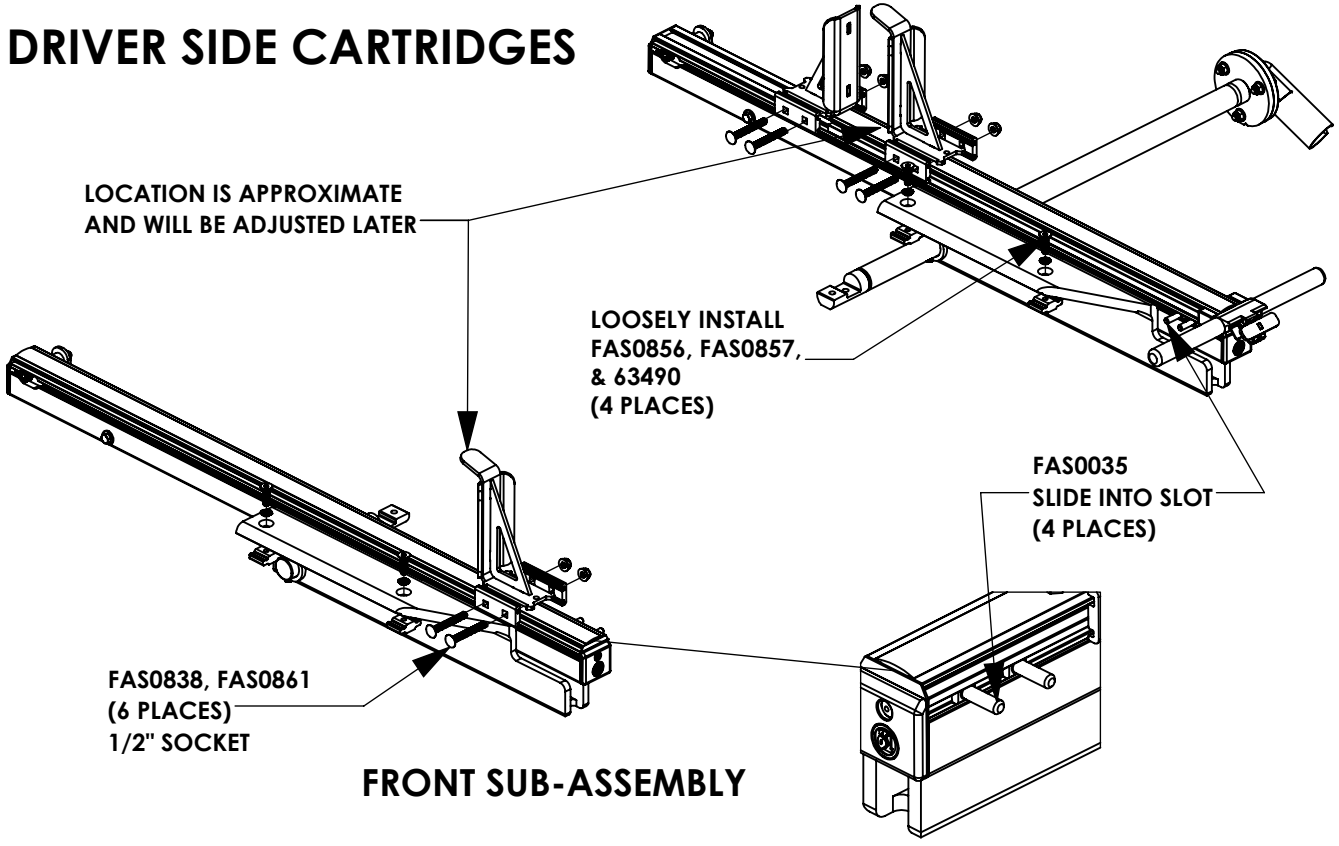
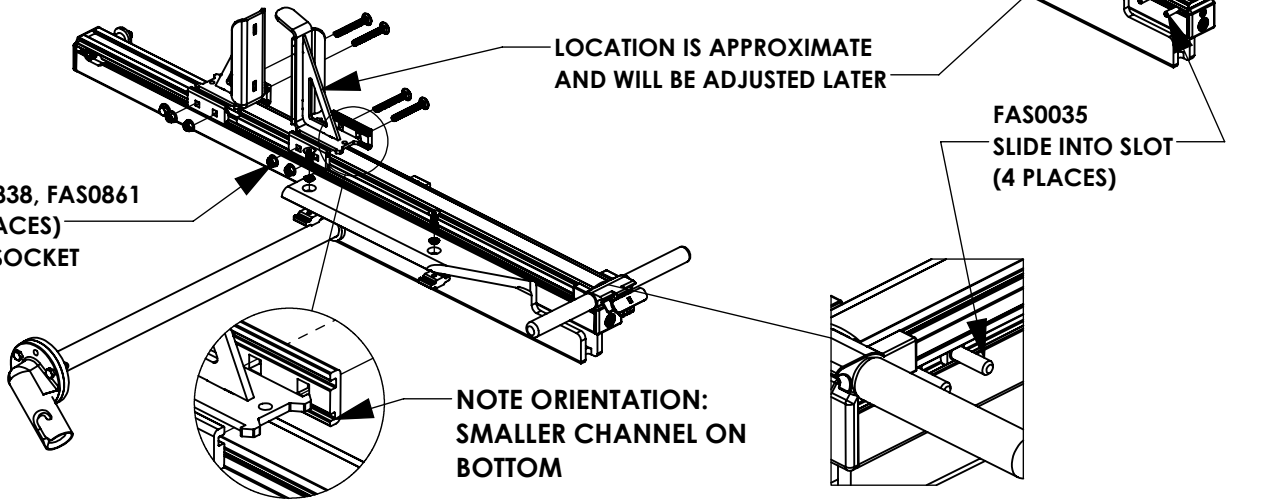

STEP 2 - MOUNT DAMPER BRACKETS AND INNER STOPS TO CROSSBOWS

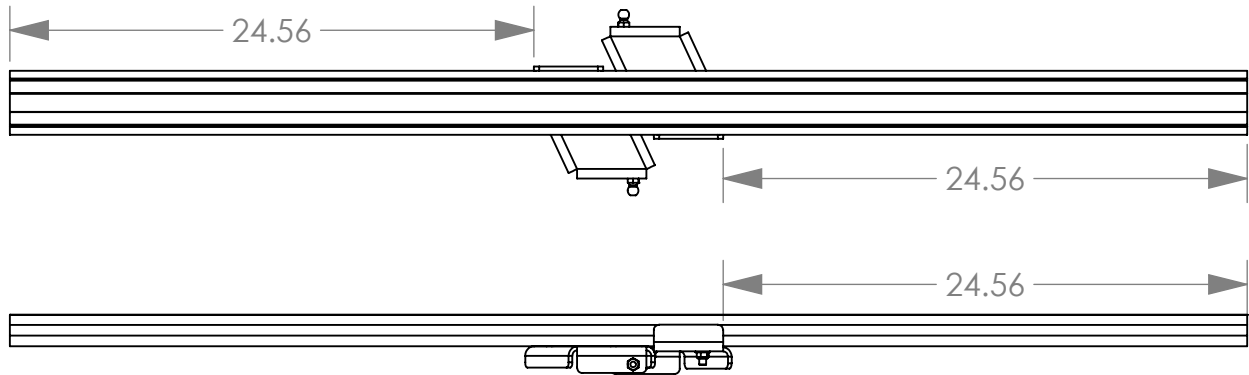
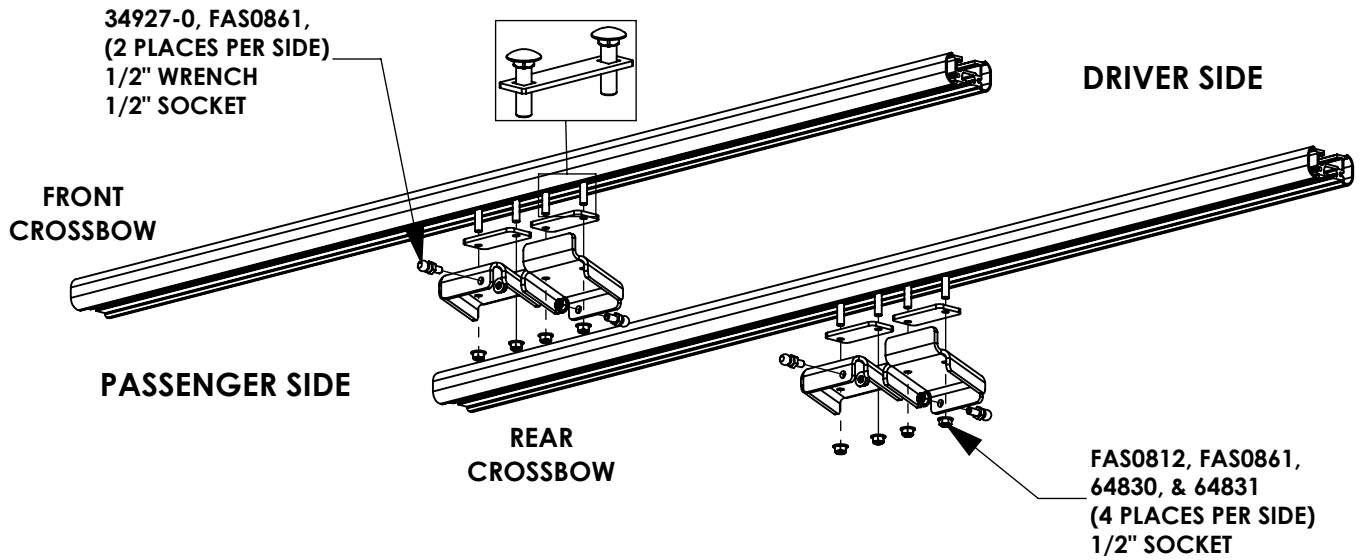

FAS0283, FAS0552,
FAS0861
(1 PLACE PER SIDE)
1/2" SOCKET

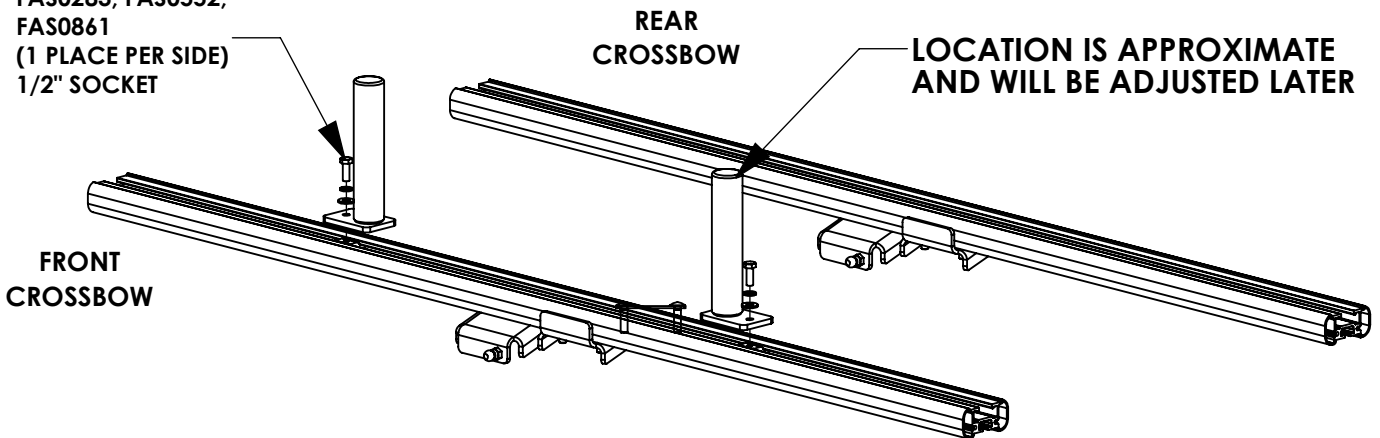

STEP 3 - INSTALL CARTRIDGES ON CROSSBOWS

FULLY TIGHTEN
FAS0856, FAS0857,
& 63490
(4 PLACES PER SIDE)
3/16" ALLEN

PASSENGER SIDE

DRIVELINE WILL BE
UNDER CROSSBOW

DRIVER SIDE

SLIDE CARTRIDGES
ONTO CROSSBOWS

LINE UP CORNERS WITH
END OF CROSSBOWS

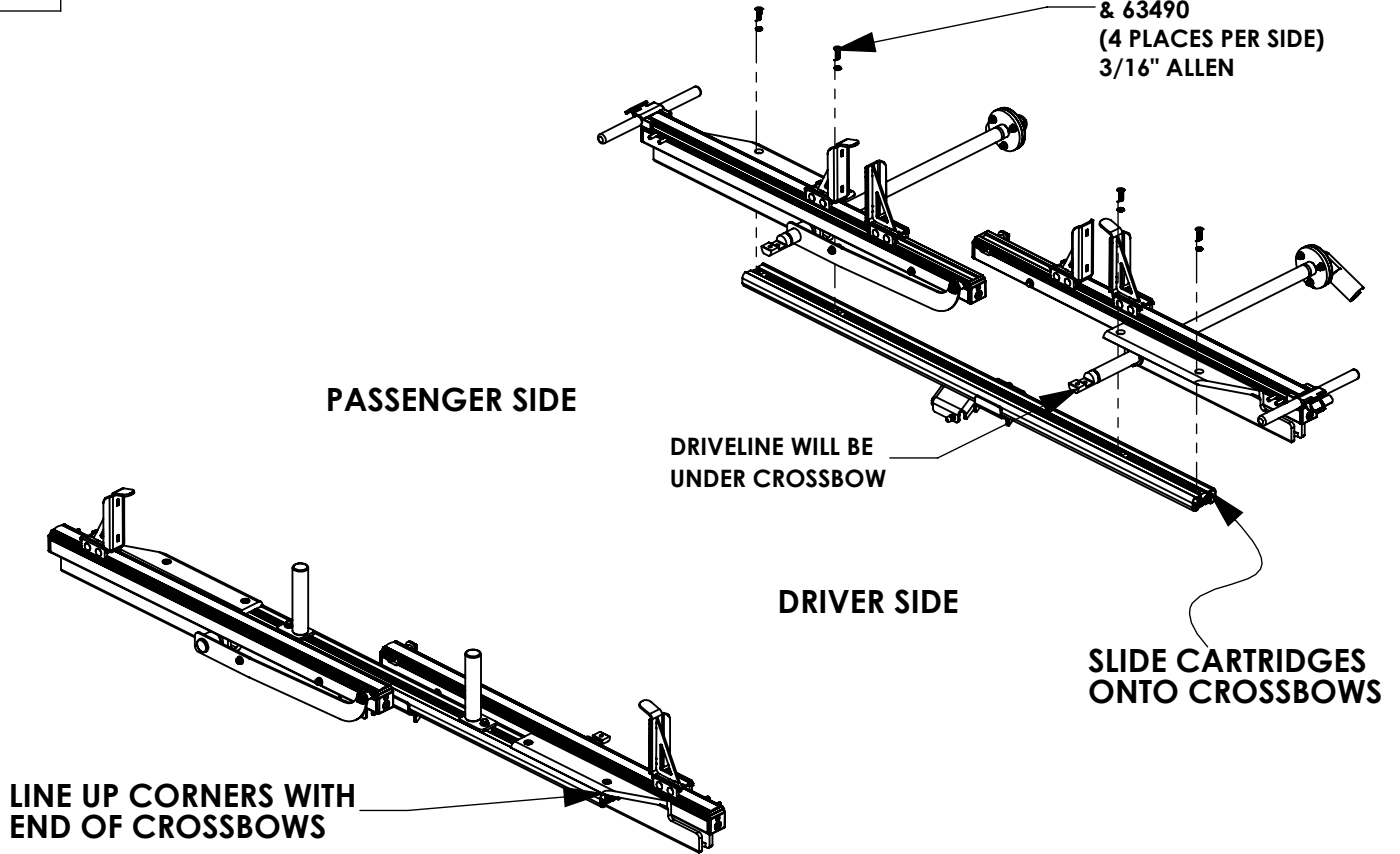

STEP 4 - INSTALL DAMPERS

48265
EXTENSION DAMPER

ATTACH DAMPERS
TO BALL STUDS

INSERT 34928-0 LOCKING
PINS AFTER MOUNTING
TO BALL STUDS
(4 PLACES PER SIDE)

58239
COMPRESSION DAMPER

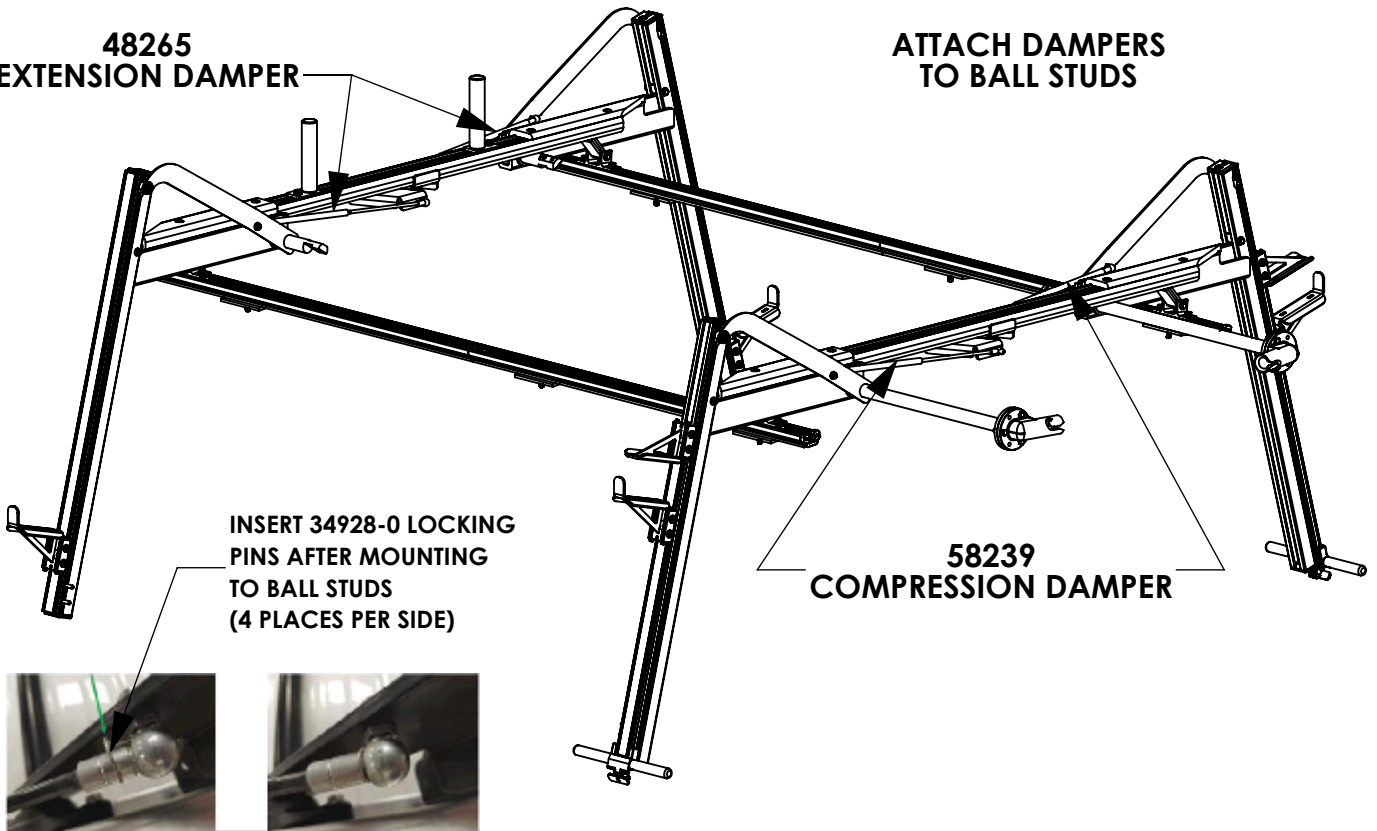

STEP 5 - INSTALL DRIVELINE AND O.S. BAR

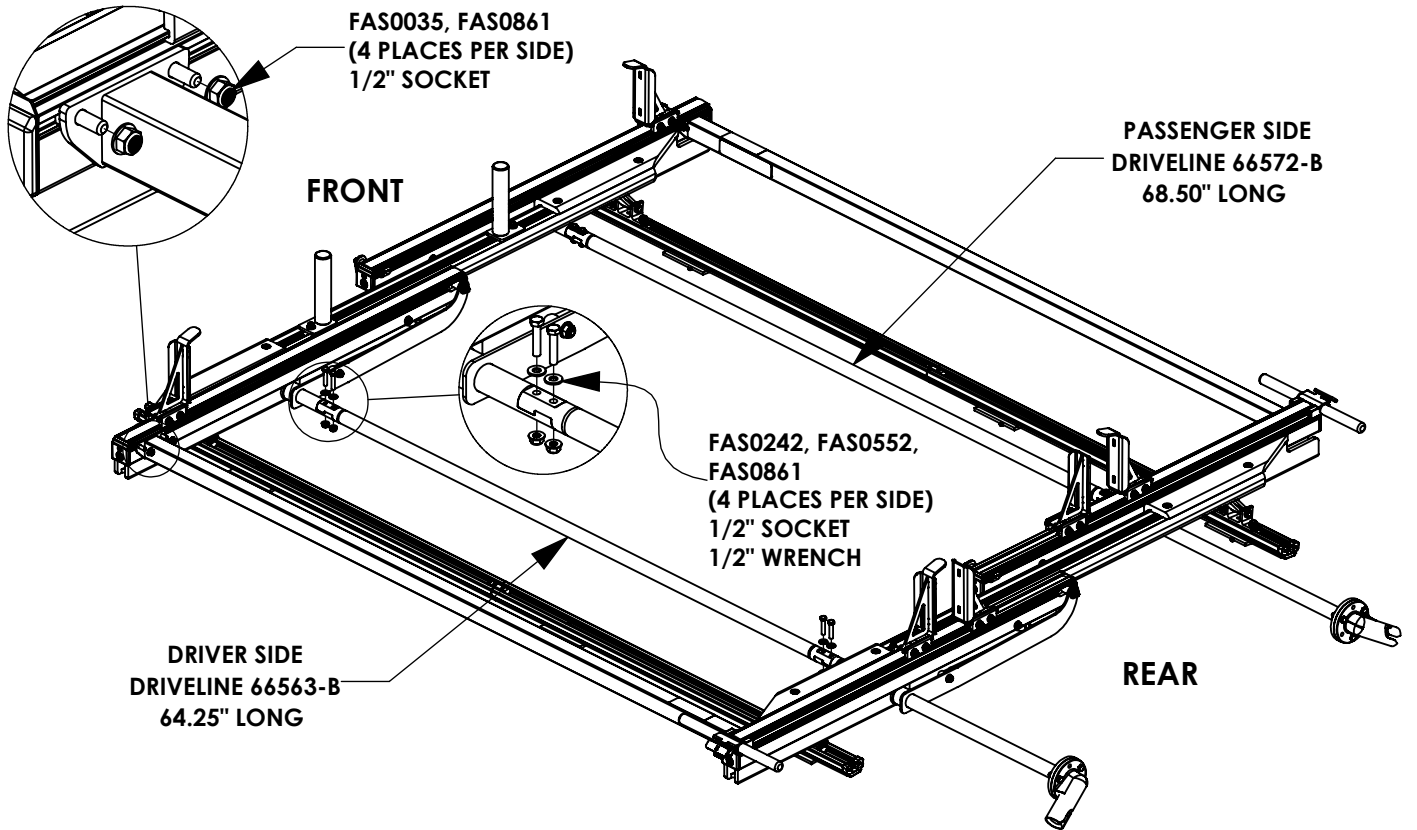

STEP 6 - INSTALL CROSSBOW END CAPS

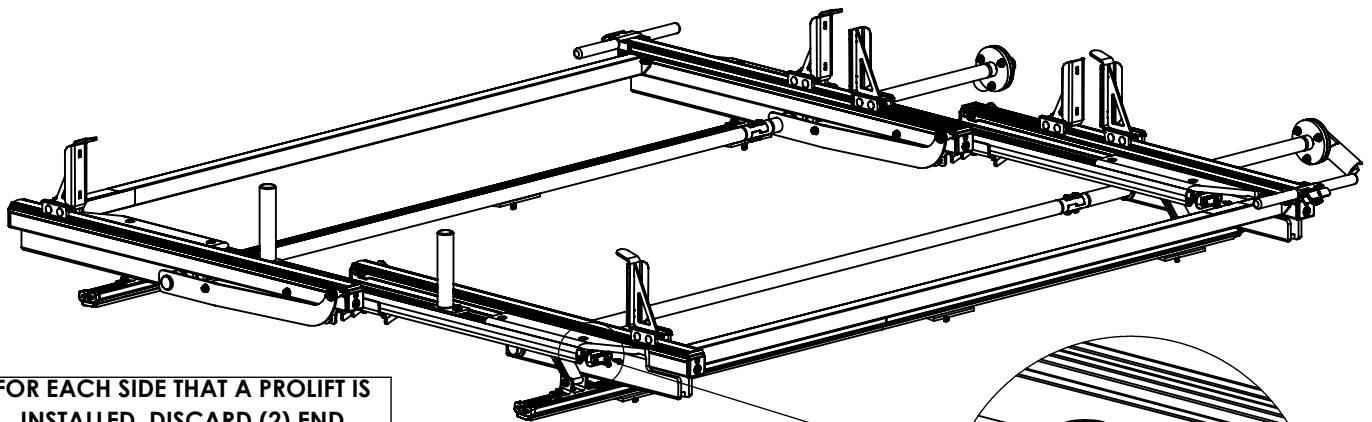

FOR EACH SIDE THAT A PROLIFT IS
INSTALLED, DISCARD (2) END
CAPS THAT ARE INCLUDED WITH
THE CROSSBOW KIT.

SHOWN BELOW:



65961, (2) FAS0473
(2 PLACES PER SIDE)
5/16" SOCKET

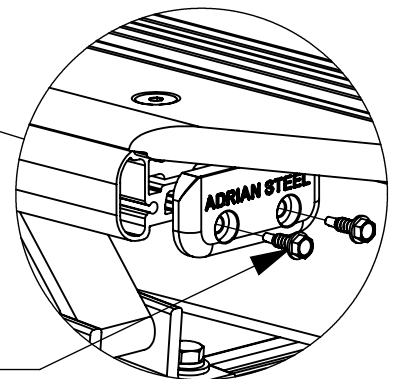

STEP 7 - INSTALL HANDLE STORAGE HARDWARE

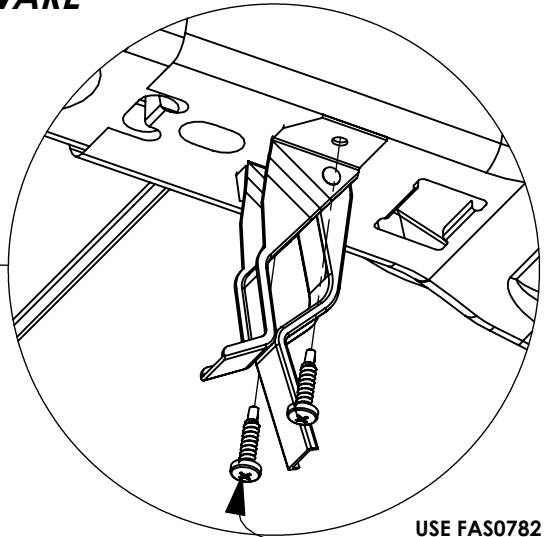
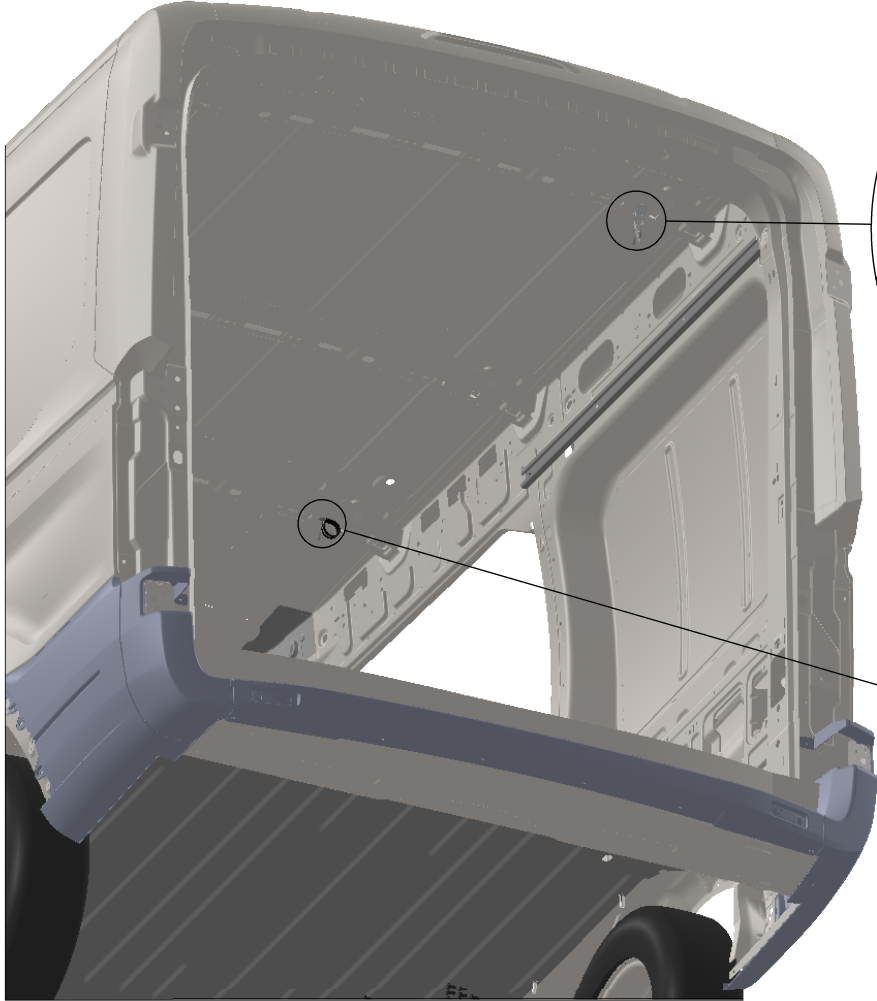

USE FAS0782
(3 PLACES)
#2 PHILLIPS

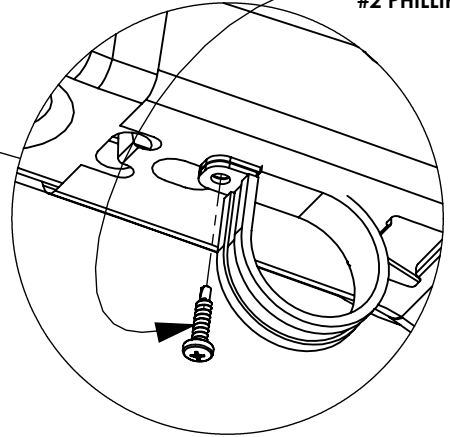

STEP 8 - CLIP HANDLE INTO STORAGE CLIP

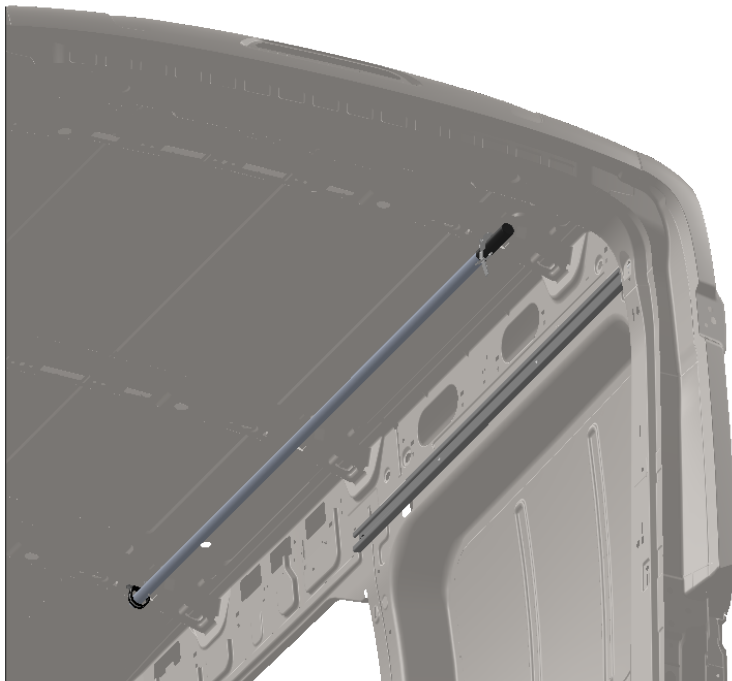

<i>INSTR. NUMBER</i> : 67270	<i>PG:</i> 1	<i>REV:</i> C	<i>ITEM NO.</i>	<i>PART NUMBER</i>	<i>DESCRIPTION</i>	<i>QTY.</i>
			1	63386	Foot Clamp 2, Promaster	6
<i>PART NUMBER</i> : RRKPM			2	63387	Foot Clamp, Promaster	6
			3	63373	ROOF RAIL PM 118, 159, 159EXT	4
<i>PART</i> • ROOF RAIL KIT, <i>DESC.</i> • PROMASTER FSV						

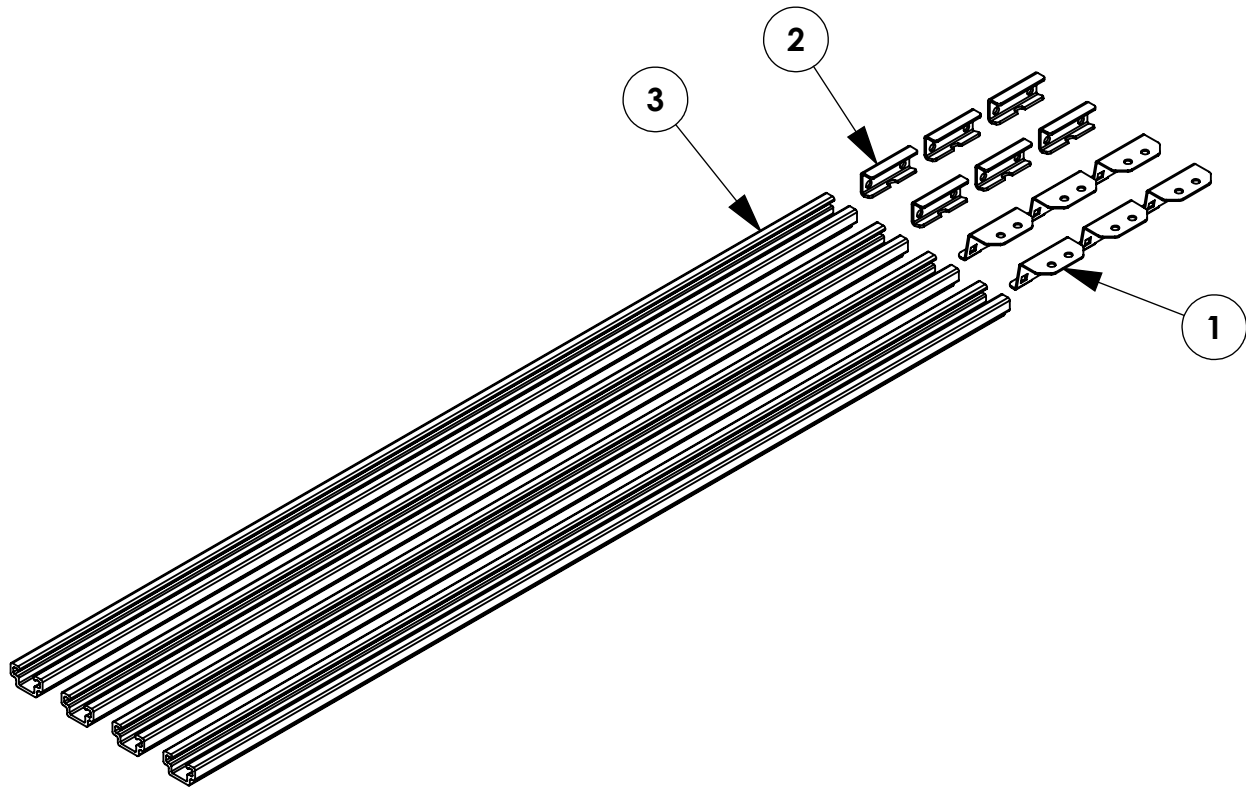

GET TO KNOW THE VEHICLE - AT THE BEGINNING OF ANY INSTALLATION, CHECK THE LOCATION OF THE FUEL TANK, FUEL LINES, BRAKE LINES, HIGH VOLTAGE BATTERIES AND WIRING HARNESES TO AVOID INJURY OR PROPERTY DAMAGE FROM TOOL CONTACT.

SEAL ALL EXTERIOR HOLES - ALL INSTALLATION HOLES SHOULD BE SEALED WITH BUTYL TAPE OR SILICON TO PREVENT WATER AND EXHAUST GASES FROM ENTERING THE VEHICLE.

CONTROL DRILL DEPTH - TO AVOID DAMAGE TO THE VEHICLE, USE A DRILL STOP OR CLEARED STEP BIT WHEN DRILLING INSTALLATION HOLES.

ALWAYS ADD PRIMER - WHEN ADDING INSTALLATION HOLES BE SURE TO USE A SELF-ETCHING PRIMER TO PREVENT CORROSION, FASTENER FAILURE AND INJURY.

MOUNTING POINTS MUST HAVE METAL-TO-METAL CONTACT - USE PROVIDED MOUNTING SPACERS TO ACCOMMODATE FOR VEHICLE FEATURES, CARPET OR SUBFLOORS.

PROVIDE CLEARANCE FOR SPACERS - IF THE INSTALLATION VEHICLE CONTAINS A CARPET OR SUBFLOOR, USE A 1-3/16" DIAMETER CARPET CUTTER (P/N: 31183-0) AT ALL MOUNTING LOCATIONS TO OPEN UP ROOM FOR SPACERS.

CHECK SPACER ORIENTATION - BE SURE THAT THE INDENT IN THE SPACER COVERS THE PLUSNUT HEAD; THIS ENSURES THE MOST METAL-TO-METAL CONTACT AND REDUCES VIBRATION.

PLUSNUT INSTALLATION - A PLUSNUT GUN IS RECOMMENDED FOR PLUSNUT INSTALLATION FOR ITS PRODUCTION SPEED. HOWEVER, A PLUSNUT SETTING TOOL CAN ALSO BE USED (P/N: 22200-0).

THRU-BOLT CLEARANCE - WHEN USING A THRU-BOLT AT ANY MOUNTING LOCATION, BE SURE THAT YOUR HOLE HAS 1/16" CLEARANCE.

FASTENERS USED

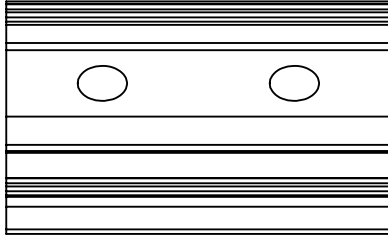

63491
RAIL CONNECTOR, 2"
QTY: 8



FAS0497
SET SCREW SS
5/16-18X.75
QTY: 4

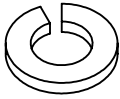

FAS0588
WASHER, LOCK SPLIT
5/16 SS
QTY: 12

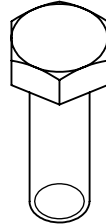

FAS0597
SCREW, HEX HD
5/16-18X1.00 SS
QTY: 12

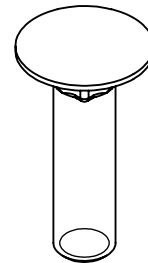

FAS0812
BOLT, CARRIAGE
5/16-18X1.25 SS
QTY: 12

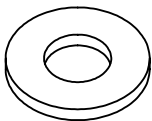

FAS0552
WASHER, FLAT
5/16 SS
QTY: 24

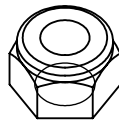

FAS0248
NUT, NYLON LOCK
5/16-18 SS
QTY: 12

**ROOF RAIL INSTALL LOCATION - 118, 159, 159 EXTENDED WHEEL BASES
LOW & HIGH ROOF**

**ALIGN
CENTER OF
BRACKET
WITH CENTER
OF ROOF
PEG AND
TIGHTEN
DOWN**

6.81 FROM
END OF RAIL
TO START OF
FIRST BRACKET
(BOTH SIDES)

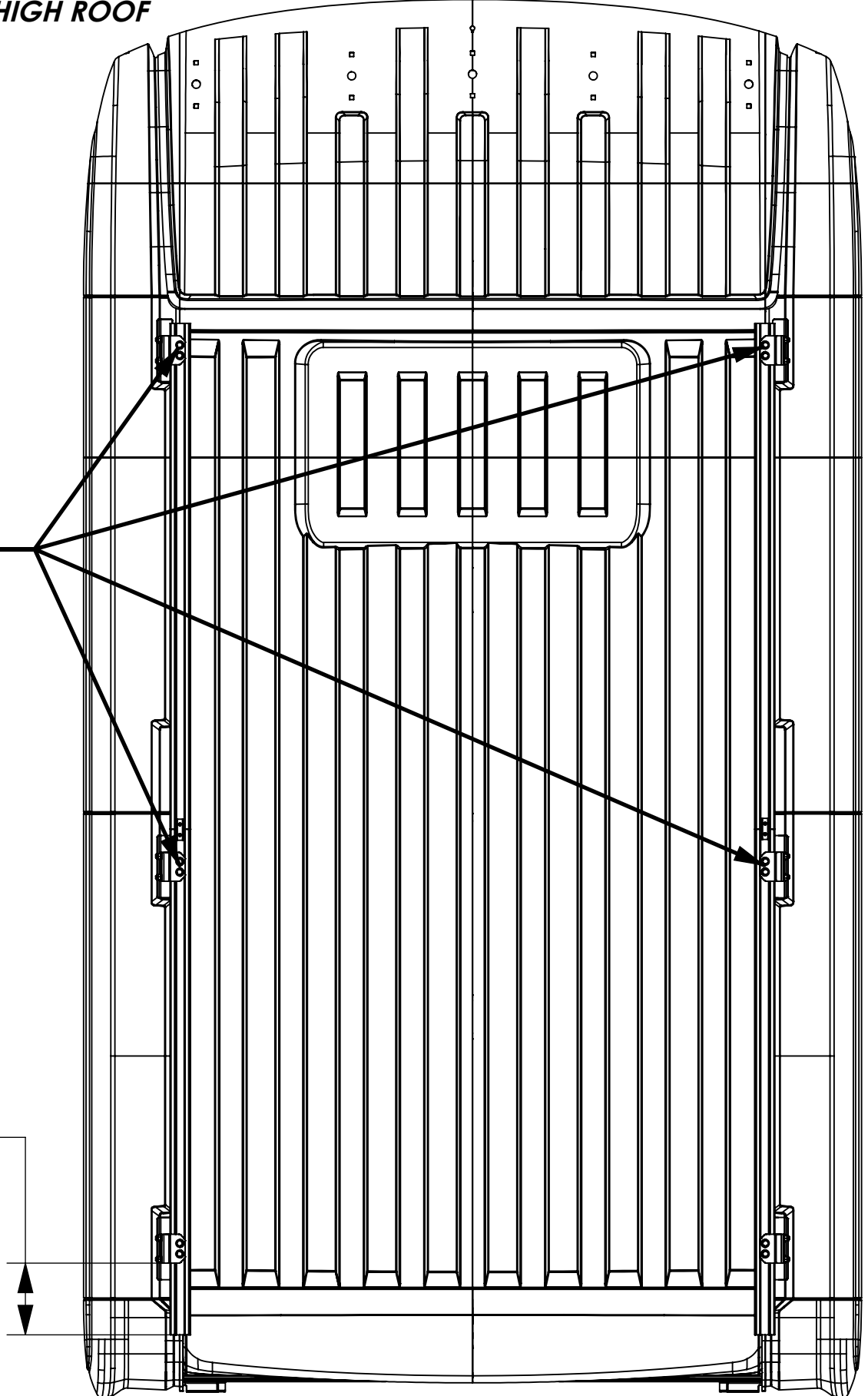

CONNECT ROOF RAILS

STEP 1 - SLIDE RAILS TOGETHER. CENTER SLIDE BETWEEN TWO RAILS AND TIGHTEN DOWN SET SCREWS

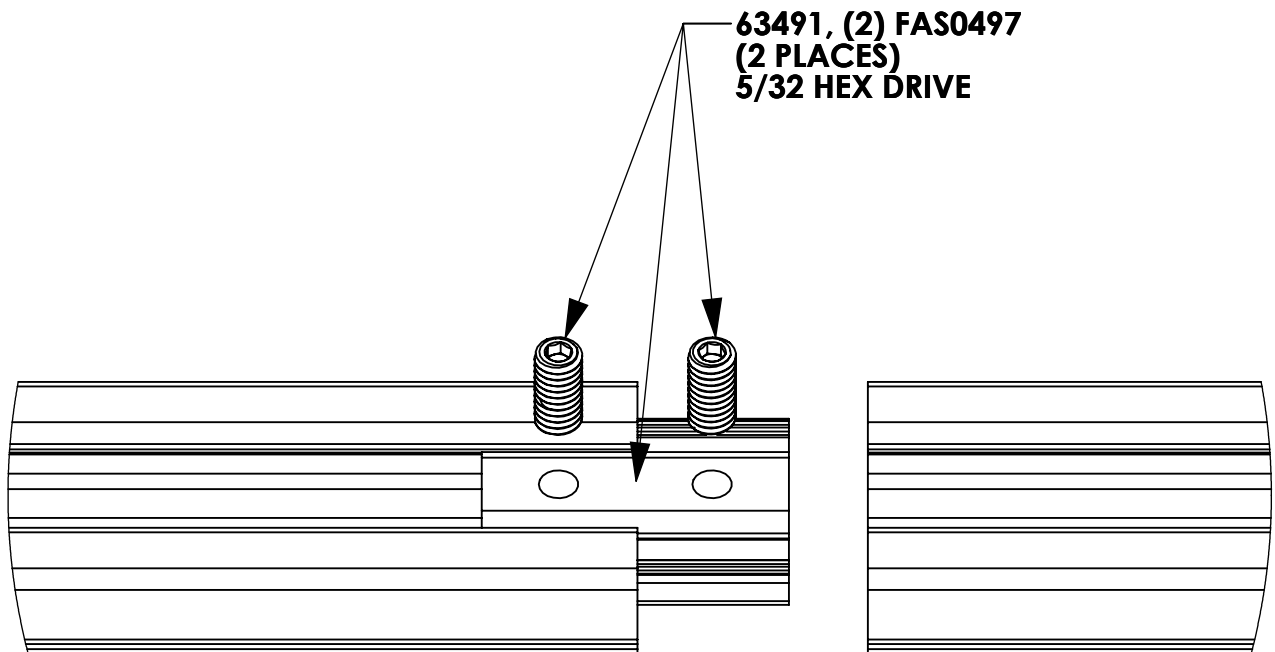

BEGIN INSTALLATION

STEP 2 - INSTALL RAIL AND BRACKETS TO ROOF OF VEHICLE

(2) FAS0597, (2) FAS0588,
(2) FAS0552, 63491
(6 PLACES)
1/2" WRENCH

63386

63387

(2) FAS0812, (2) FAS05552,
(2) FAS0248
(6 PLACES)
1/2" WRENCH

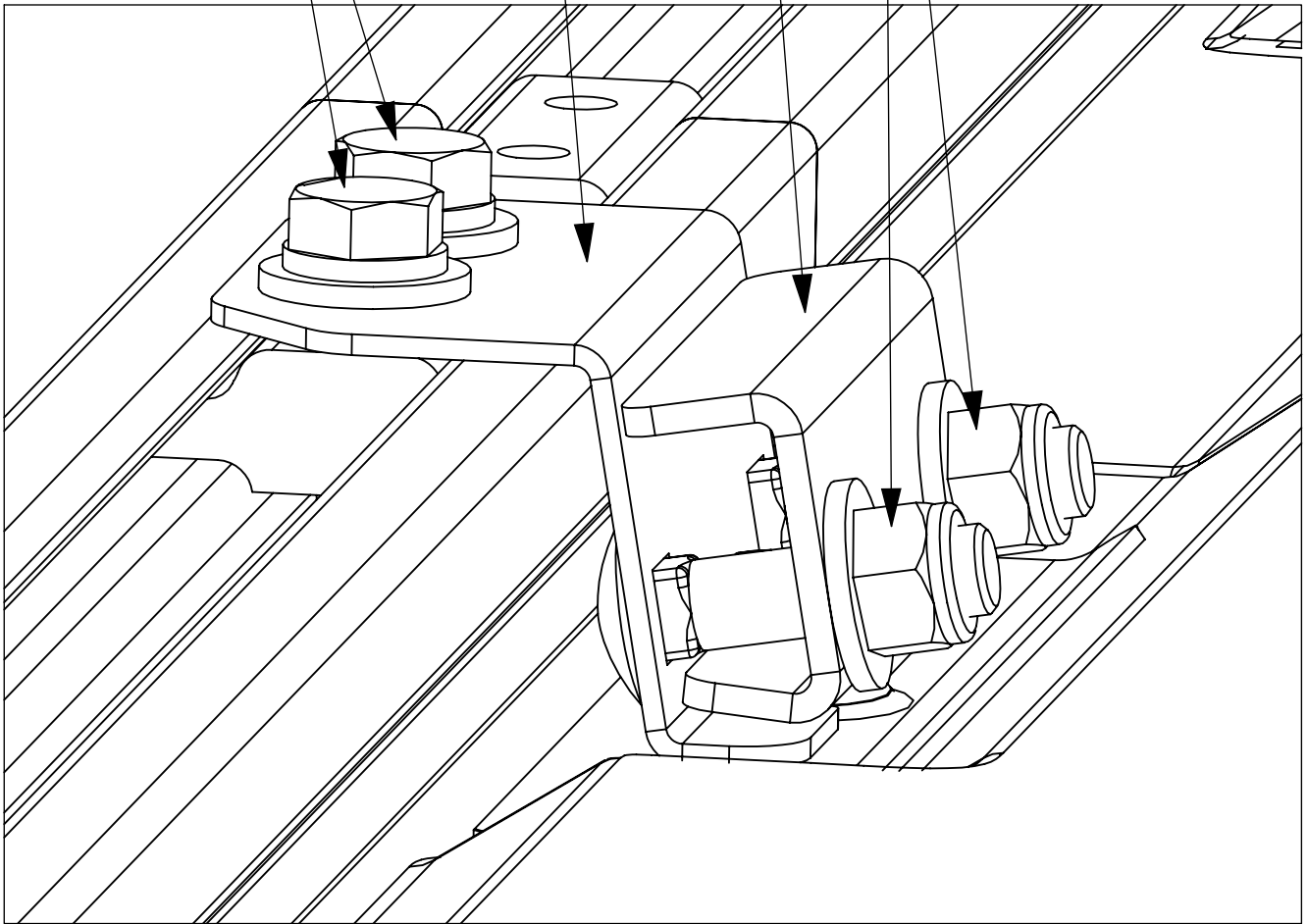



Mounting Bracket Kit, 4-Pack, White, Multiple Pickups

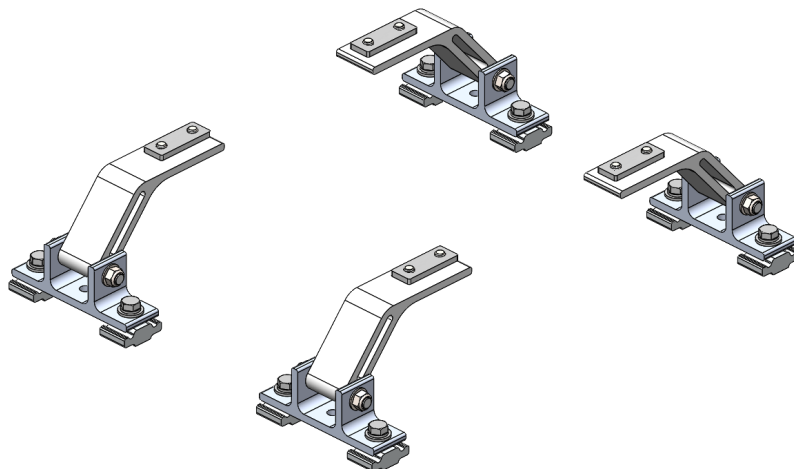

PRODUCT WEIGHT
4.0 LBS

HEIGHT OFF ROOF
SEE TABLE BELOW

CAPACITY
**REFER TO OEM'S
RECOMMENDED LOAD
RATING**
COLOR

WHITE

CATALOG NUMBER

URMBK4W

PRODUCT FEATURES

Aluminum mounting bracket kit for the PROFILE™ HD Utility, Grip-Lock, and/or ProLift ladder racks. Only works with the OEM specific, Adrian Steel supplied roof rail kit.

Utility and Grip-Lock racks are not recommended for medium or high roof vehicles!

Reference respective OEM specific roof rail kit for more detailed list of compatible accessories.

SEE PAGE 2 FOR APPLICATION NOTES AND ACCESSORIES, OTHER PRODUCTS THAT WORK WITH THIS UNIT.

PAGE 1 of 2

The information contained in this document is the sole property of ADRIAN STEEL COMPANY. ADRIAN STEEL COMPANY retains the right to modify and/or change the product of its design at any time without prior notification.



CATALOG NUMBER URMBK4W

PRODUCT APPLICATION

This product is designed to work with OEM specific rail kit for HD Utility, Grip-Lock, and/or ProLift racks. HD Utility and Grip-Lock racks are not recommended for medium or high roof vehicles!

ACCESSORIES THAT WILL WORK WITH THIS PRODUCT

CATALOG NUMBER	DESCRIPTION	CATALOG NUMBER	DESCRIPTION
RRKFT	Mounting Roof Rail Kit, Transit	RRKNVFSV	Mounting Roof Rail Kit, NV
RRKSP	Mounting Roof Rail Kit, Sprinter	RRKPM	Mounting Roof Rail Kit, ProMaster, 118" WB, 159" WB, 159" WB Extended
RRKPM136WB	Mounting Roof Rail Kit, ProMaster, 136" WB	RRKSBTOP	Mounting Roof Rail Kit, Multiple Pickups
RRKLBTOP	Mounting Roof Rail Kit, Multiple Pickups		

Reference respective OEM specific roof rail kit for more detailed list of compatible accessories.

INSTR. NUMBER : 66850	PG: 1	REV: D	ITEM NO.	PART NUMBER	DESCRIPTION	URMBK4W	URMBK2W
	PART NUMBER : URMBK		1	65123-W	UTILITY, FT MOUNT ARM, ST, W	4	2
PART DESC. : UTILITY, MNT BKT KT, RAIL			2	63852-W	UTILITY, MOUNTING BRKT, W	4	2

**-PART NUMBERS WITH "-W" SUFFIX ARE PAINTED WHITE
-FOR BLACK MOUNTING KITS, REPLACE "-W" PARTS WITH "-B" PARTS**

NOTE: THIS INSTRUCTION IS VALID FOR THE FOLLOWING KITS:

- URMBK4W
- URMBK4B
- URMBK2W
- URMBK2B

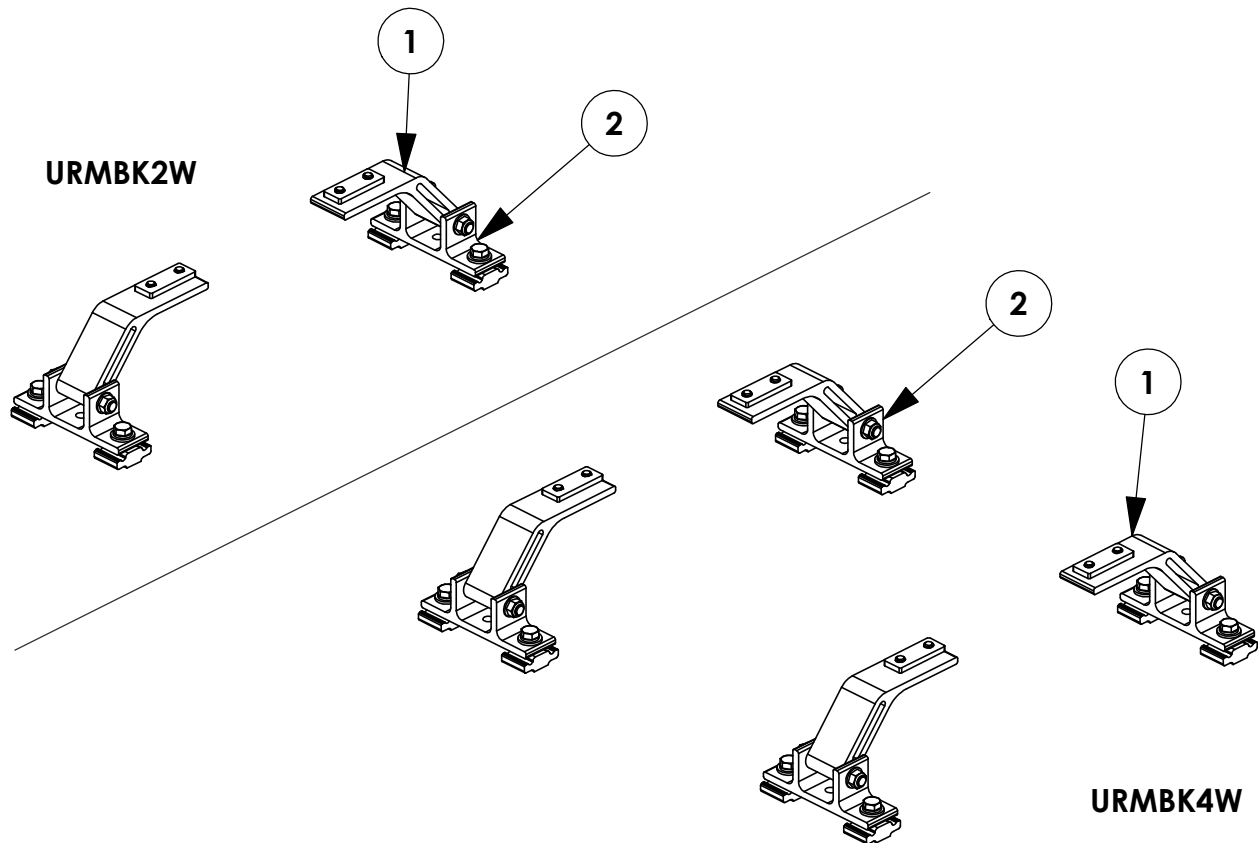

TOOLS NEEDED:

- DRIVE RATCHET
- IMPACT DRIVER
- 3/16" SOCKET
- 1/2" SOCKET
- 1/2" WRENCH
- TAPE MEASURE

GET TO KNOW THE VEHICLE - AT THE BEGINNING OF ANY INSTALLATION, CHECK THE LOCATION OF THE FUEL TANK, FUEL LINES, BRAKE LINES, HIGH VOLTAGE BATTERIES AND WIRING HARNESSSES TO AVOID INJURY OR PROPERTY DAMAGE FROM TOOL CONTACT.

SEAL ALL EXTERIOR HOLES - ALL INSTALLATION HOLES SHOULD BE SEALED WITH BUTYL TAPE OR SILICON TO PREVENT WATER AND EXHAUST GASES FROM ENTERING THE VEHICLE.

CONTROL DRILL DEPTH - TO AVOID DAMAGE TO THE VEHICLE, USE A DRILL STOP OR CLEARED STEP BIT WHEN DRILLING INSTALLATION HOLES.

ALWAYS ADD PRIMER - WHEN ADDING INSTALLATION HOLES BE SURE TO USE A SELF-ETCHING PRIMER TO PREVENT CORROSION, FASTENER FAILURE AND INJURY.

MOUNTING POINTS MUST HAVE METAL-TO-METAL CONTACT - USE PROVIDED MOUNTING SPACERS TO ACCOMMODATE FOR VEHICLE FEATURES, CARPET OR SUBFLOORS.

PROVIDE CLEARANCE FOR SPACERS - IF THE INSTALLATION VEHICLE CONTAINS A CARPET OR SUBFLOOR, USE A 1-3/16" DIAMETER CARPET CUTTER (P/N: 31183-0) AT ALL MOUNTING LOCATIONS TO OPEN UP ROOM FOR SPACERS.

CHECK SPACER ORIENTATION - BE SURE THAT THE INDENT IN THE SPACER COVERS THE PLUSNUT HEAD; THIS ENSURES THE MOST METAL-TO-METAL CONTACT AND REDUCES VIBRATION.

PLUSNUT INSTALLATION - A PLUSNUT GUN IS RECOMMENDED FOR PLUSNUT INSTALLATION FOR ITS PRODUCTION SPEED. HOWEVER, A PLUSNUT SETTING TOOL CAN ALSO BE USED (P/N: 22200-0).

THRU-BOLT CLEARANCE - WHEN USING A THRU-BOLT AT ANY MOUNTING LOCATION, BE SURE THAT YOUR HOLE HAS 1/16" CLEARANCE.

FASTENERS AND HARDWARE USED

BAG REFERENCE: BAG66848

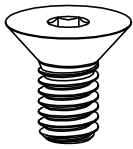

FAS0858
5/16-18X.63
FHH SCREW
QTY: 8

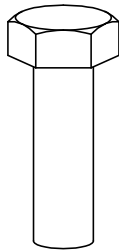

FAS0597
5/16-18X1.0 SS
HH SCREW
QTY: 8



FAS0243
5/16-18X2.5 SS
HH SCREW
QTY: 4



FAS0857
5/16 SS WASHER,
LOCK EXT CS
QTY: 8



FAS0588
5/16 SS
SPLIT WASHER
QTY: 8



FAS0552
5/16 SS
FLAT WASHER
QTY: 12

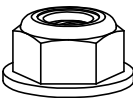

FAS0861
5/16-18 SS
HH FLG NUT
QTY: 4

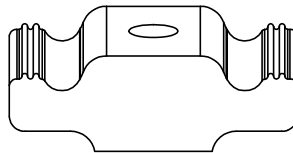

63490
RAIL SLIDE,
1"
QTY: 8

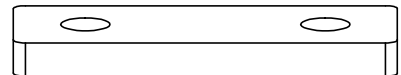

68042
PROFILE FOOT
MOUNTING PLATE
QTY: 4

PAGE INTENTIONALLY LEFT BLANK

STEP 1 - ASSEMBLE MOUNTING ARMS TO CROSSBOW



CHECK TABLE 1-3 IN INSTRUCTION 68895 FOR ADDITIONAL ACCESSORY SLIDE INSTALLATION BEFORE INSTALLING MOUNTING BRACKETS (ALL A.2 ITEMS SHOULD BE COMPLETELY ASSEMBLED FIRST!)

STEP 1.1
LOOSELY ASSEMBLE
UNTIL AFTER STEP 3
(2) FAS0857, (2)
FAS0858, 68042

(02 PLACES PER
CROSSBOW)
3/16" ALLEN

ATTENTION!

IF INSTALLING A GRIP-LOCK ON A PICKUP TRUCK TOPPER, ASSEMBLE MOUNTING ARMS FACING OUTWARD FOR THAT SIDE OF THE RACK

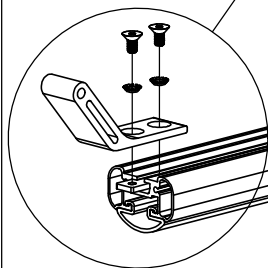
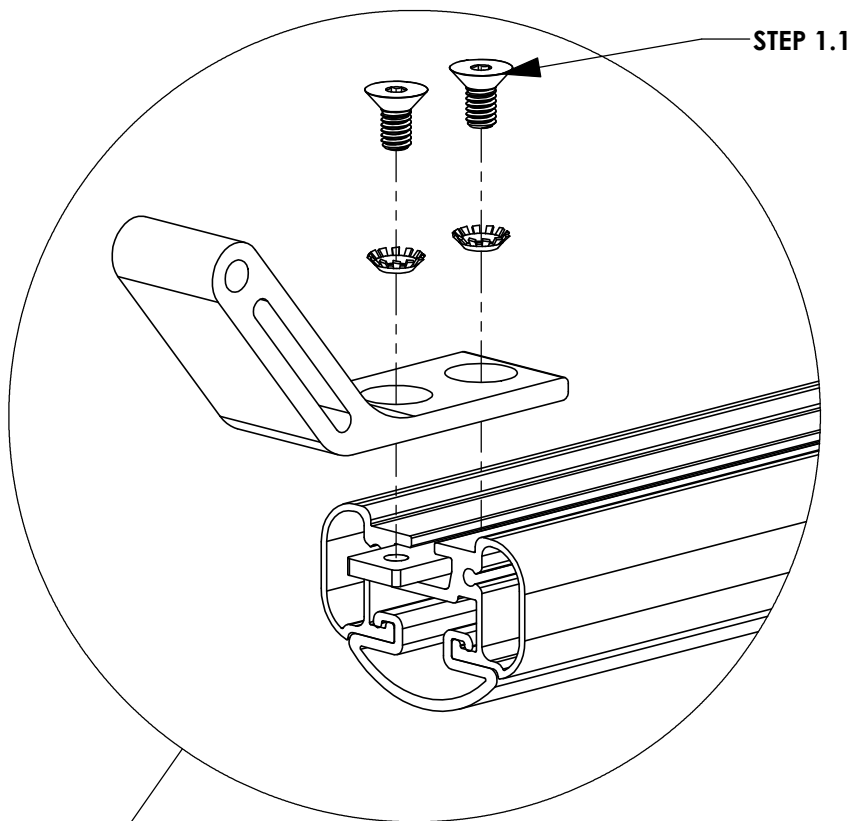

SLIDES AND FASTENERS WILL BE INCLUDED IN THEIR RESPECTIVE KITS. THESE SHOULD BE INSERTED PRIOR TO ASSEMBLING MOUNTING ARMS!

STEP 2 - SECURE CROSSBOW

FULL SIZE VANS

CENTER CROSSBOW ON MOUNTING BRACKETS

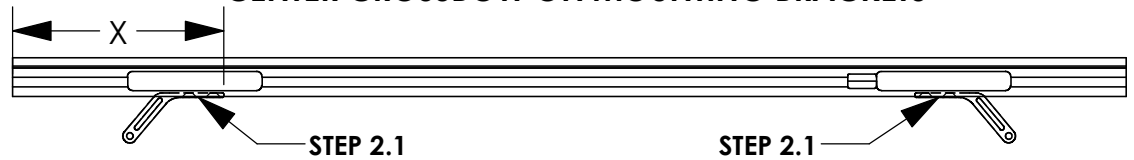

STEP 2.1
FULLY TIGHTEN
FROM STEP 1.1
 (04 PLACES PER
 CROSSBOW)
 3/16" ALLEN

VEHICLE PLATFORM	DIMENSION "X" (in.) - 58" CROSSBOW	DIMENSION "X" (in.) - 68" CROSSBOW
FORD TRANSIT	6 5/8"	11 5/8"
RAM PROMASTER	6"	11"
NISSAN NV	4 7/8"	9 7/8"
MERCEDES SPRINTER (LOW ROOF)	4 5/8"	9 5/8"
MERCEDES SPRINTER (HIGH ROOF)	8 1/8"	13 1/8"

**DIMENSION WILL
 VARY BASED ON
 ROOF RAIL
 PLACEMENT ON
 TOPPER**

PICKUP TRUCK TOPPERS

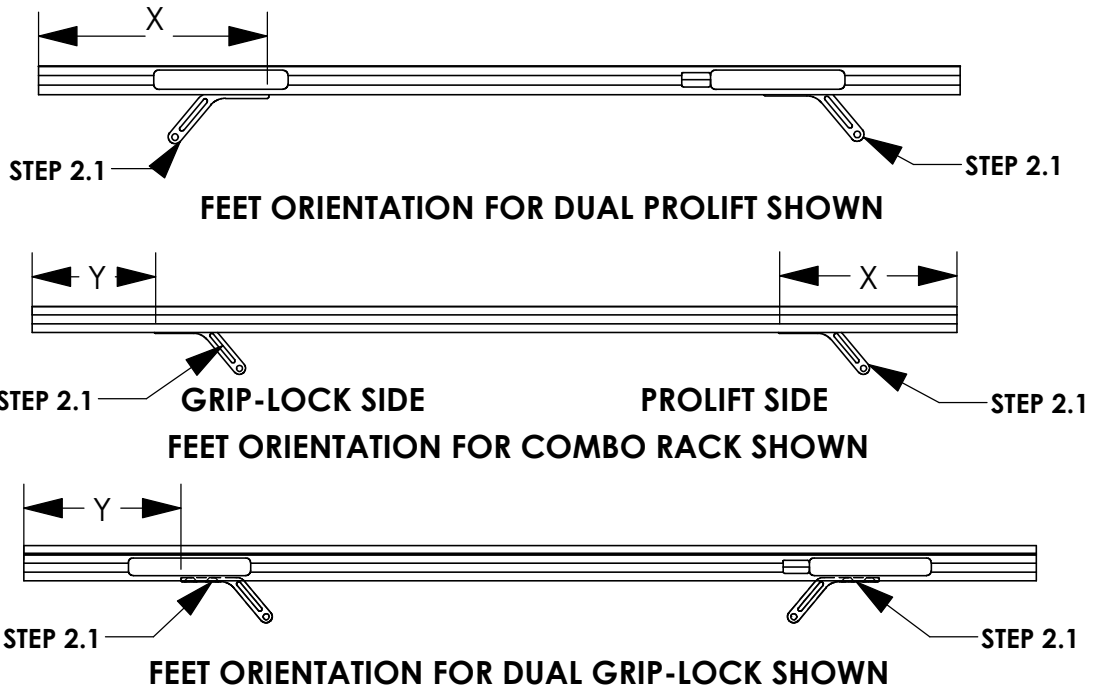

**MOUNTING FEET
 FOR GRIP LOCK SIDE
 OF COMBO RACK
 WILL FACE
 OUTWARD FROM
 ROOF CENTERLINE
 ON TOPPER**

CROSSBOW LENGTH	DIMENSION "X" (in.) - PROLIFT	DIMENSION "Y" (in.) - GRIPLOCK
48" (PROLIFT)	MINIMUM 10 1/8"	N/A
53" (COMBO)	MINIMUM 10 1/8"	MAX 7 1/8"
58" (GRIP-LOCK)	N/A	MAX 7 1/8"

**NOTE - THESE DIMENSIONS ARE APPROXIMATE AND WILL VARY
 SLIGHTLY WITH ANY TOLERANCE IN THE BUILD OF THE VEHICLE**

STEP 3 - ASSEMBLE LOWER MOUNTING FOOT TO ROOF RAIL

STEP 3.1
FULLY TIGHTEN
FAS0597, FAS0552,
FAS0588, 63490 ON
REAR MOUNTING FEET

(02 PLACES PER
MOUNTING FOOT)
1/2" SOCKET

STEP 3.2
LEAVE LOOSE UNTIL
AFTER STEP 4
FAS0597, FAS0552,
FAS0588, 63490 ON
FRONT MOUNTING
FEET

(02 PLACES PER
MOUNTING FOOT)
1/2" SOCKET

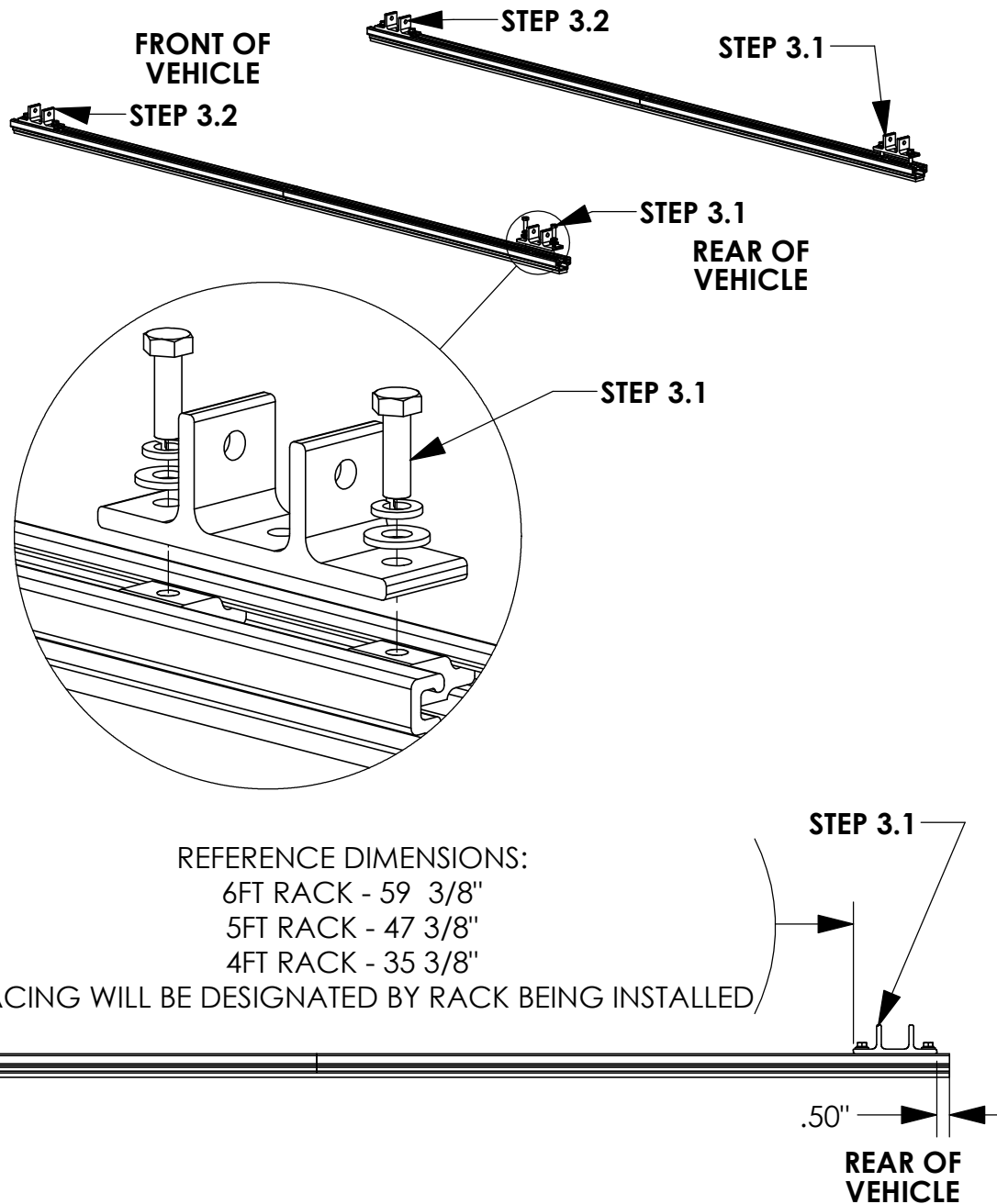

CROSSBOW POSITIONING NOTES:

HD UTILITY RACK -

REAR CROSSBOW - REARWARD AS POSSIBLE
FRONT CROSSBOW- POSITION TO BEST FIT END USER'S PRODUCT

GRIP LOCK/PROLIFT LADDER RACKS -

1/2" FROM END OF RAIL UNLESS OTHERWISE STATED IN RESPECTIVE
INSTRUCTION FOR CROSSBOW PLACEMENT.

STEP 4 - ASSEMBLE MOUNTING BRACKETS TO MOUNTING ARMS



BEFORE PROCEEDING WITH THIS STEP FINISH ASSEMBLING ACCESSORIES ONTO RACK. (IE GRIP LOCK, PROLIFT, ETC)

STEP 4.1

FULLY TIGHTEN

FAS0243, FAS0552,
FAS0861

(02 PLACES PER
CROSSBOW)

1/2" SOCKET
1/2" WRENCH

STEP 4.2

FULLY TIGHTEN

FAS0597, FAS0552,
FAS0588, 63490 ON
FRONT MOUNTING
FEET

(02 PLACES PER
MOUNTING FOOT)

1/2" SOCKET

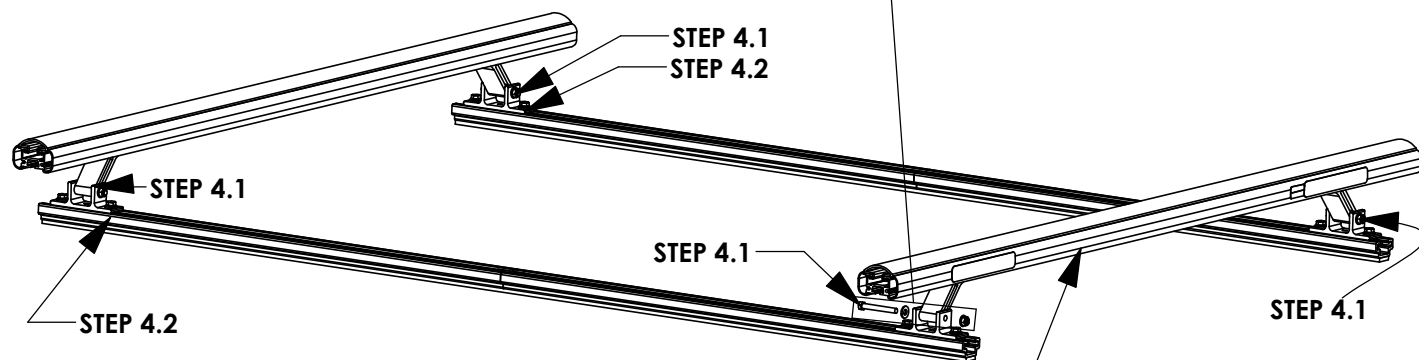
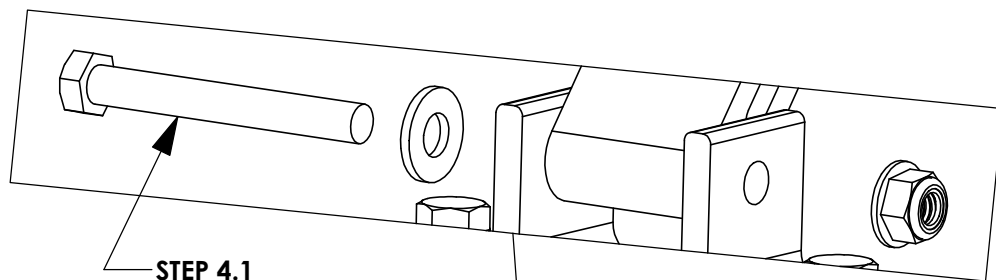

NOTE ORIENTATION OF LABELS ON CROSSBOW

REFERENCE - NO ACCESSORIES SHOWN

STEP 5 - ADJUST MOUNTING BRACKET LOCATION IF NECESSARY

CROSSBOW POSITIONING NOTES:

HD UTILITY RACK -

REAR CROSSBOW - REARWARD AS POSSIBLE
 FRONT CROSSBOW- POSITION TO BEST FIT END USER'S PRODUCT

GRIP LOCK/PROLIFT LADDER RACKS -

1/2" FROM END OF RAIL UNLESS OTHERWISE STATED IN RESPECTIVE INSTRUCTION FOR CROSSBOW PLACEMENT.

6' ARE TOPPER / 8' LEER TOPPER

**△ A OPTIMAL RAIL KIT POSITION:
 TOPPER ROOF RAIL KIT END TO BE
 A-DIM FROM BLACK TOPPER TRIM**

**△ B UTILITY MOUNTING BRACKET:
 REAR MOUNTING BRACKETS WILL BE
 B-DIM FROM THE END OF THE ROOF
 RAIL KIT**

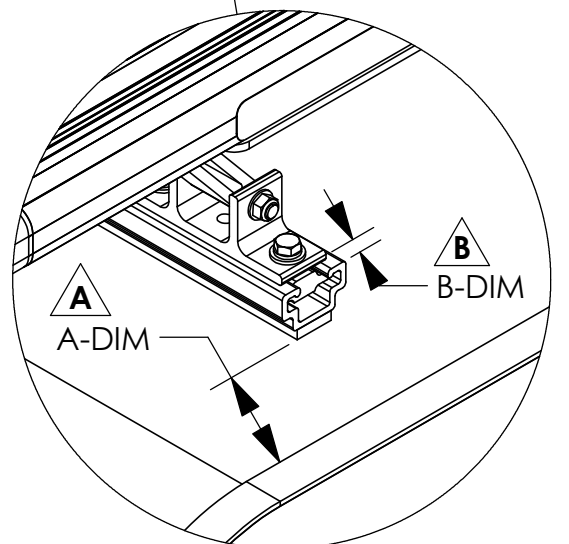
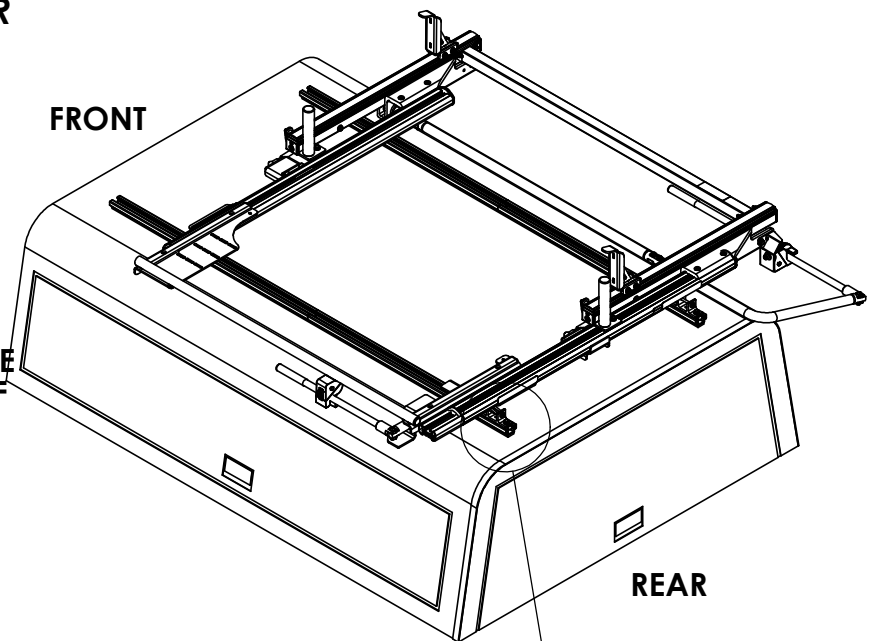

TOPPER/ DIMENSION	6' ARE TOPPER	8' LEER TOPPER
A-DIM	3.00"	1.00"
B-DIM	0.50"	0.50"

**NOTE:
 IF RAILS HAVE BEEN PREVOIUSLY INSTALLED, LOOSEN TOPPER RAIL BRACKET RAIL SLIDES
 AND ADJUST TO MEET DESIRED POSITIONING**

INSTALLATION IS COMPLETE!! MAKE SURE ALL FASTENERS ARE TIGHTENED



2-Crossbar Kit, 58", White, Minivan



PRODUCT WEIGHT
16.1 LBS

CROSSBOW LENGTH X
HEIGHT

59" x 2"

CAPACITY

**REFER TO OEM'S
RECOMMENDED LOAD
RATING**

COLOR

WHITE

CATALOG NUMBER

2BARCW

PRODUCT FEATURES

Aluminum base 2-crossbow kit for PROFILE™ HD Utility, grip lock, drop down, or combo ladder racks. Works with all compact van platforms for each respective wheelbase and Ford Transit Ship Thru. Works with and without OEM specific rail kit and generic mounting bracket kits.

Optional uprights and conduit kits available.

Please refer to OEM specific mounting kit or rail kit for additional information on compatible accessories.

INSTALLATION GUIDE FOR PROFILE™ SERIES LADDER RACKS

INSTRUCTION #:
68895

REV:
B

THIS INSTRUCTION PROVIDES A GENERAL GUIDE OF INSTALLATION SEQUENCE FOR ALL PROFILE™ SERIES LADDER RACKS. PLEASE ENSURE ALL ACCESSORIES ARE INSTALLED PER TYPE OF RACK BEFORE PROCEEDING TO NEXT PAGE.

REFERENCE THIS INSTRUCTION THROUGHOUT THE ENTIRETY OF YOUR INSTALL TO PREVENT ACCESSORIES BEING INSTALLED INCORRECTLY/OUT OF SEQUENCE!

STEPS 21 - 81 ON PAGE 3 IS THE RECOMMENDED ASSEMBLY SEQUENCE FOR A FULL TABLE ASSEMBLY BEFORE INSTALLING ON THE ROOF OF THE VEHICLE.

STEPS 2R - 8R ON PAGE 4 IS AN ALTERNATE ASSEMBLY SEQUENCE TO INSTALL THE RACK ON THE VEHICLE ROOF AS IT IS BUILT.

PLEASE SELECT THE ASSEMBLY SEQUENCE THAT BEST WORKS FOR YOU!

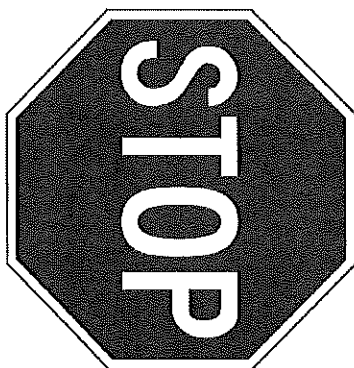

ASSEMBLY STEPS:

STEP 1A. SUB-ASSEMBLE EACH CROSSBOW WITH DESIRED ACCESSORIES FOR SECTIONS A.1 & A.2.

INSTRUCTIONS FOR EACH KIT CAN BE FOUND IN THEIR RESPECTIVE CARTON!

TOP OF CROSSBOW *IMAGE NOT TO SCALE!

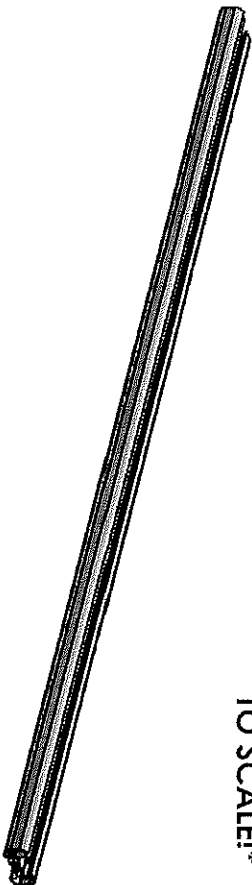

BOTTOM OF CROSSBOW

TABLE 1

TOP OF CROSSBOW		COMPONENTS TO INSTALL
HD UTILITY		- CONDUIT KIT OR BEACON
Grip-Lock		- CONDUIT KIT OR BEACON
Prolift		- CONDUIT KIT OR BEACON
BOTTOM OF CROSSBOW		
COMPONENTS TO INSTALL		
HD UTILITY		- LADDER STOP, STROBE BRACKET, AND/OR REAR ROLLER
Grip-Lock		- Grip-Lock SUB-ASSEMBLY
Prolift		- DAMPER BRACKET

STEP 1B. SUB-ASSEMBLE EACH CROSSBOW WITH DESIRED ACCESSORIES FOR SECTIONS B.1 & B.2. INSTRUCTIONS FOR EACH KIT CAN BE FOUND IN THEIR RESPECTIVE CARTON!

TOP OF CROSSBOW

IMAGE NOT TO SCALE!

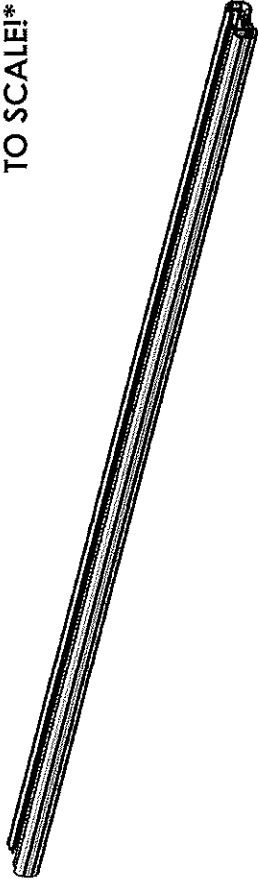

BOTTOM OF CROSSBOW

TABLE 2

TOP OF CROSSBOW	
	COMPONENTS TO INSTALL
HD UTILITY	- WEAR STRIP (MODIFY IF NECESSARY, TABLE 3)
Grip-Lock	- WEAR STRIP (MODIFY IF NECESSARY, TABLE 3)
ProLift	- INNER STOP POST
BOTTOM OF CROSSBOW	
	COMPONENTS TO INSTALL
HD UTILITY	- MOUNTING BRACKETS
Grip-Lock	- MOUNTING BRACKETS
ProLift	- MOUNTING BRACKETS

ALTER WEAR STRIP AND INSTALL ON CROSSBOW (IF APPLICABLE)! REFERENCE TABLE 3 BELOW FOR WEAR STRIP ALTERATION INSTRUCTIONS!

TABLE 3

ADDED ACCESSORIES	ALTERATION FOR WEAR STRIP
4" UPRIGHT***	REMOVE 2" FROM END OF WEAR STRIP
4" PVC CONDUIT KIT	REMOVE 7.25" FROM CENTER OF WEAR STRIP
6" PVC CONDUIT KIT	REMOVE 9.50" FROM CENTER OF WEAR STRIP
ALUMINUM BOX CONDUIT KIT	REMOVE 13.25" FROM CENTER OF WEAR STRIP
BEACON	REMOVE 4" FROM CENTER OF WEAR STRIP
ProLift (SINGLE SIDE)	CUT WEAR STRIP IN HALF, DO NOT INSTALL ON ProLift SIDE
ProLift (DUAL SIDE)	DO NOT INSTALL WEAR STRIP

SLIDE WEAR STRIP INTO RAIL AND CENTER (1 PER CROSSBOW)

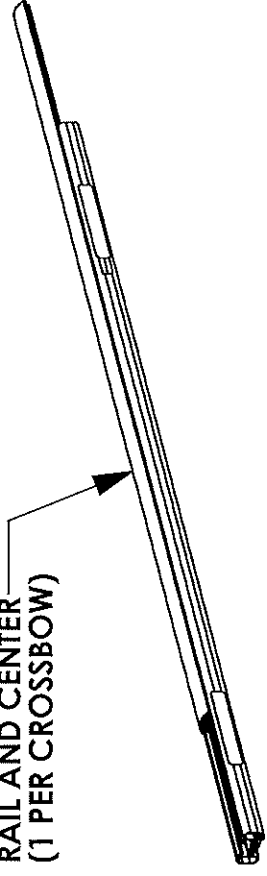

STEP 1C SUB-ASSEMBLE EACH CROSSBOW WITH DESIRED ACCESSORIES FOR SECTIONS C.1 & C.2

TOP OF CROSSBOW
IMAGE NOT TO SCALE!

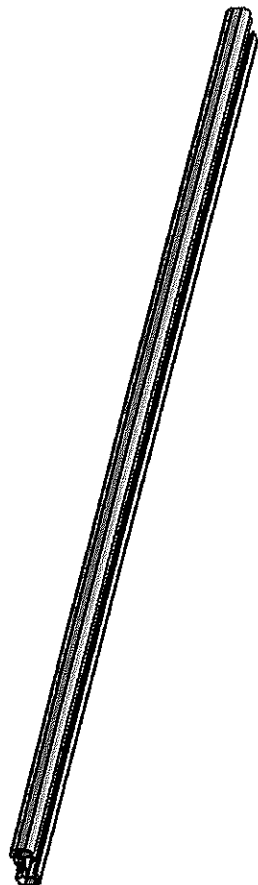

BOTTOM OF CROSSBOW

TABLE 4

TOP OF CROSSBOW		COMPONENTS TO INSTALL
	HD UTILITY	- 4" UPRIGHT
C.1	Grip-Lock	- N/A
	Prolift	- SLIDES FOR BASE EXTRUSION
BOTTOM OF CROSSBOW		
	COMPONENTS TO INSTALL	
	HD UTILITY	- UPRIGHTS (6", 9", RATCHET)
C.2	Grip-Lock	- STROBES
	Prolift	- STROBES

ASSEMBLY STEPS (FULL BENCH ASSEMBLY):

- 2T. ADD DRIVELINES (IF INSTALLING Prolift)
- 3T. ADD HANDLES (IF INSTALLING Grip-Lock OR Prolift) AND DAMPERS (IF INSTALLING Prolift)
- 4T. ADD OUTER SUPPORT BARS (IF INSTALLING Grip-Lock OR Prolift)
- 5T. ADD STEP LADDER KIT (Grip-Lock OR Prolift ONLY)

6T. ASSEMBLE ENDS CAPS TO CROSSBOW

USED FOR HD UTILITY & Grip-Lock RACKS

LOCATED IN CROSSBOW KIT

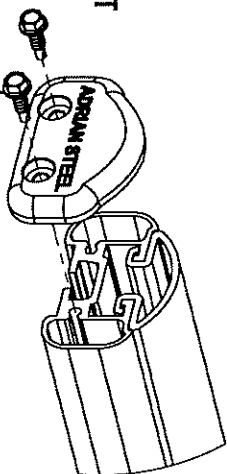

FULLY TIGHTEN
(2) FAS0473, 63851
(2 PLACES PER END CAP)
5/16" SOCKET

USED FOR Prolift RACKS
LOCATED IN Prolift Kit

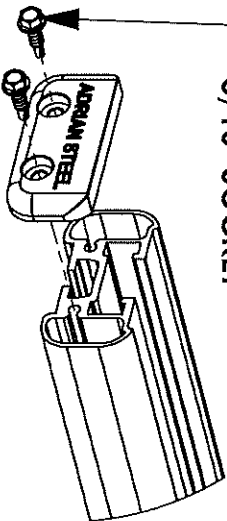

7T. INSTALL ROOF RAIL KIT ON VEHICLE ROOF OR BOTTOM MOUNTING BRACKETS

(ROOF RAIL KIT REQUIRED FOR Grip-Lock & Prolift OPTIONAL FOR HD UTILITY, NOT NEEDED FOR GM LADDER RACKS)

8T. MOUNT CROSSBOW SUB-ASSEMBLIES FROM STEP 1 TO VEHICLE/MOUNTING BRACKET, OR ROOF RAIL (LOOSE INSTALL)

ALTERNATE ASSEMBLY METHOD!
(ASSEMBLE ON VEHICLE ROOF):

- 2R. INSTALL ROOF RAIL KIT ON VEHICLE ROOF OR BOTTOM MOUNTING BRACKETS
(ROOF RAIL KIT REQUIRED FOR Grip-Lock & ProLift, OPTIONAL FOR HD UTILITY, NOT NEEDED FOR GM LADDER RACKS)
- 3R. MOUNT CROSSBOW SUB-ASSEMBLIES FROM STEP 1 TO VEHICLE/MOUNTING BRACKET, OR ROOF RAIL (LOOSE INSTALL)
- 4R. ADD DRIVELINES (IF INSTALLING ProLift)
- 5R. ADD HANDLES (IF INSTALLING Grip-Lock OR ProLift) AND DAMPERS (IF INSTALLING ProLift)
- 6R. ADD OUTER SUPPORT BARS (IF INSTALLING Grip-Lock OR ProLift)
- 7R. ADD STEP LADDER KIT (Grip-Lock OR ProLift ONLY!)

8R. ASSEMBLE END CAPS TO CROSSBOW

USED FOR HD UTILITY & Grip-Lock RACKS

LOCATED IN CROSSBOW KIT

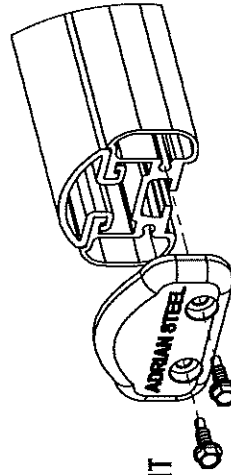

FULLY TIGHTEN
(2) FAS0473, 63851
(2 PLACES PER END CAP)
5/16" SOCKET

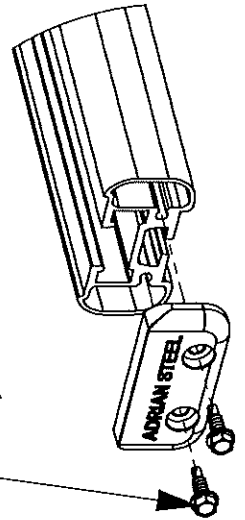

USED FOR ProLift RACKS
LOCATED IN ProLift Kit