

THIS DRAWING IS THE PROPERTY OF ADRIAN STEEL COMPANY AND IS NOT TO BE USED IN ANY MANNER  
DETRIMENTAL TO THE INTERESTS OF ADRIAN STEEL COMPANY

**FASTENER DATA**

PRINTED DOCUMENT IS UNCONTROLLED

Sheet 1 of 1

**TOLERANCES & INSPECTION**

**RELEASE & REVISIONS**

THREAD SIZE: <b>1/4-20</b>	MATERIAL: STAINLESS STEEL/NYLON
THREAD CLASS: <b>2B</b>	FASTENER GRADE:
THREAD LENGTH:	HEX SIZE: <b>7/16</b>
POINT STYLE:	FINISH: <b>WAX WITH TRACER</b>
POINT STYLE:	ASTM B1117, SALT SPRAY:
PATCH:	SPECIAL TREATMENT:
WAX COATING W/TRACER: <b>YES</b>	<b>NYLON INSERT</b>

**PART / PRODUCT IDENTIFICATION**

REVISION LEVEL  
**B**

UNLESS OTHERWISE SPECIFIED  
ALL DIMENSIONS ARE IN INCHES.  
ALL FASTENERS TO BE  
MANUFACTURED TO CONFORM  
TO APPLICABLE ASTM/IFI STANDARDS  
FOR FASTENERS.  
REFERENCE DIMENSIONS (X.XXX)  
DO NOT REQUIRE INSPECTION

INITIAL ECN: **7041**  
CURRENT ECN: **23036**  
ECN DESCRIPTION:  
**ADD WAX WITH TRACER**   
REVISED BY: **C. MOHLER**

**ADRIAN STEEL**  
ADRIAN STEEL COMPANY  
906 JAMES STREET, ADRIAN, MI 49221

DESIGNED BY: **DEL OLIVER**

DESCRIPTION: **Nut, Nylon Insert Lock, 1/4-20 SST**

WEIGHT (Lbs.): <b>0.0080</b>	SEGMENT CODE: <b>FAS</b>	PART NUMBER: <b>FAS0125</b>
------------------------------	--------------------------	-----------------------------

### Introduction / Comments:

**THESE KITS, WHEN COMBINED WITH YOUR PVC PIPE, AND INSTALLED ON THE UTILITY OR LADDER RACK PROVIDE STORAGE FOR CONDUIT AND SIMILAR ITEMS ON THE ROOF OF YOUR VAN.**

**Note:**

It is advised that all fasteners used in this assembly and installation of this Rack should be checked for tightness at the following intervals: @ 2-weeks and again @ 6-weeks of operation. This preventive maintenance step must be completed to ensure your package gives you long service life.

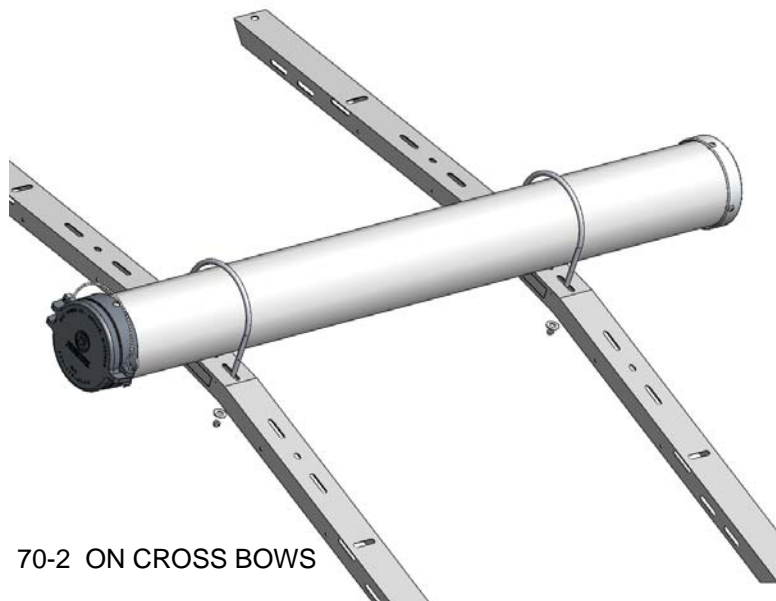

70-2 ON CROSS BOWS

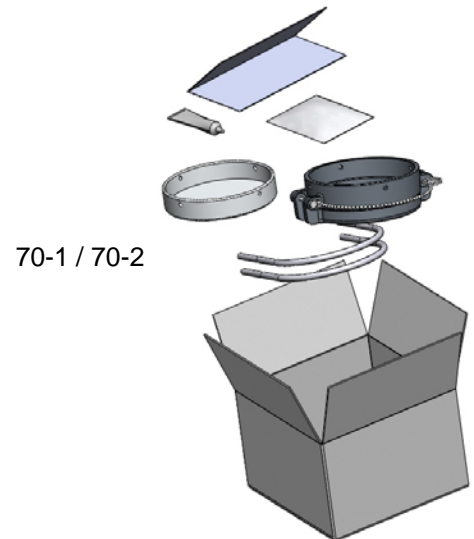

70-1 / 70-2

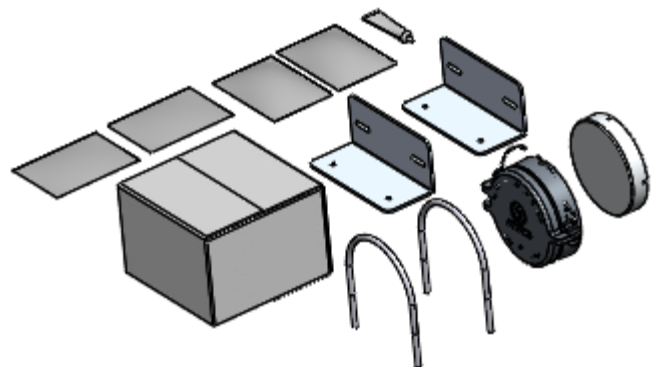

70-1LR / 70-2LR

**NOTE:**

RECOMMENDED USE OF A 6.4mm SETTING CAPACITY GUN FOR INSTALLATION. FOR INSTALLATION WE RECOMMEND THE USE OF THE FOLLOWING RIVET GUN MODELS (BOTH ARE POP® BRAND RIVET GUNS).

**DESCRIPTION:**

ProSet® 3400

ProSet® 3400MCS

**ARTICLE NUMBER:**

63407

63408

## **70-1 / 70-1LR (4") & 70-2 / 70-2LR (6") CONDUIT CARRIER KITS**

## - PRECAUTIONS -



**CAUTION**

**THE USE OF AIR IMPACT TOOLS CAN OVER-TORQUE FASTENERS AND CAUSE FASTENER FAILURE!**



**CAUTION**

**ALL INSTALLATION HOLES SHOULD BE SEALED WITH SILICON OR BUTYL SEALANT TO PREVENT EXHAUST FUMES FROM ENTERING THE VEHICLE!**



**DANGER**

**INSPECT FOR FUEL TANK, FUEL LINES, BRAKE LINES, HIGH VOLTAGE BATTERIES AND ELECTRICAL LINES PRIOR TO DRILLING TO AVOID DAMAGING CRITICAL VEHICLE SYSTEMS OR INJURY TO INSTALLER DURING INSTALLATION PROCESS!**



**CAUTION**

**TO AVOID DAMAGING THE VEHICLE ALWAYS USE DRILL STOPS WHEN DRILLING ANY INSTALLATION HOLES!**



## - IMPORTANT WARRANTY REQUIREMENTS -

1. SUBSTITUTING ADRIAN STEEL SPECIFIED FASTENERS FOR ASSEMBLY AND/OR INSTALLATION WILL VOID YOUR PRODUCT WARRANTY.
2. ALL HOLES DRILLED INTO VEHICLE SHOULD HAVE THE RAW METAL EDGES SEALED WITH A SELF-ETCHING PRIMER TO RESIST CORROSION AND POTENTIAL FASTENER POINT FAILURE.
3. ALL FASTENERS USED IN THE INSTALLATION OF THIS PRODUCT SHOULD BE TIGHTENED TO THE TORQUE(S) SPECIFIED IN THESE INSTRUCTIONS.
4. THESE INSTRUCTIONS SHOULD BE KEPT WITH THE VEHICLE.

### THE BASIC TOOLS NEEDED FOR MOST INSTALLATIONS



DRILL



DRILL BIT WITH STOP



RATCHET, SOCKETS AND/OR WRENCHES



SCREWDRIVERS



MEASURING TAPE

ADDITIONAL TOOLS MAY BE NEEDED FOR THIS INSTALLATION AND THEY WILL BE IDENTIFIED IN THE STEPS THAT FOLLOW.

**BAG70-1 FASTENER BAG**

ITEM NO.	PART NUMBER	DESCRIPTION	QTY.
1	FAS0110	Nut, Hex Nylk 3/8-16 SS W	4
2	FAS0104	Washer, Flat, 3/8, NI ZN	4
3	BAG0406-A	4" x 6" 3MIL AUTOBAG	1
4	FAS 0652 uncrimped	Rivet, Blind, Splitting, Buttonhead, 1/4x.25 Grip	8

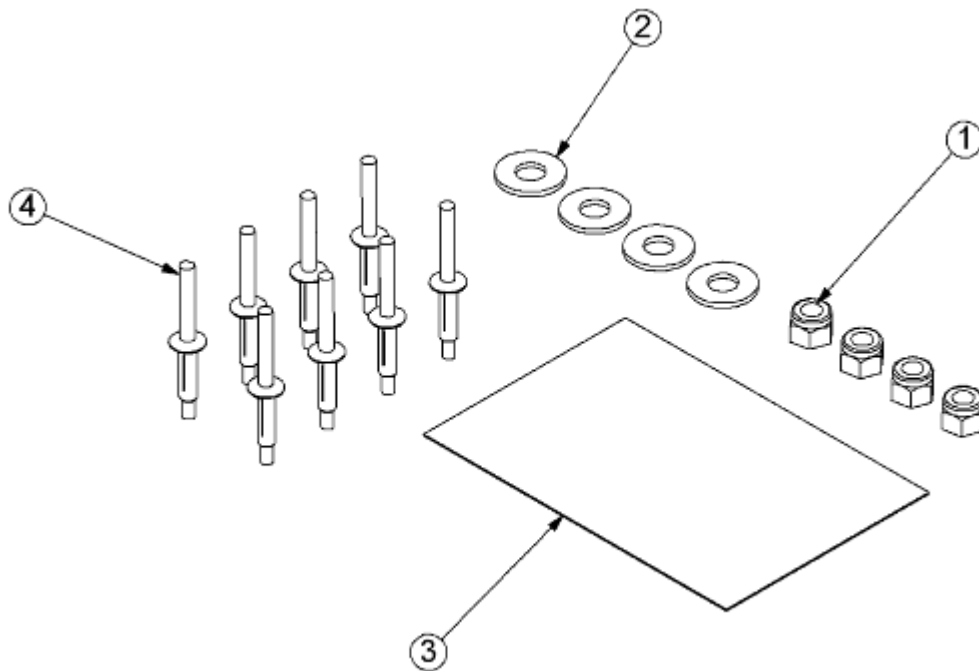

**BAG51693 FASTENER BAG**

(FOR 70-1LR AND 70-2LR)

ITEM NO.	PART NUMBER	DESCRIPTION	QTY.
1	BAG51693	BAG, FAS, ASM, 51693	1
2	FAS0248	Nut, Nylon Insert Lock, 5/16-18 SST	4
3	FAS0813	Screw, BHCS, 5/16-18X1.00, SS	4
4	FAS0552	Washer, Flat, 5/16, SST	4

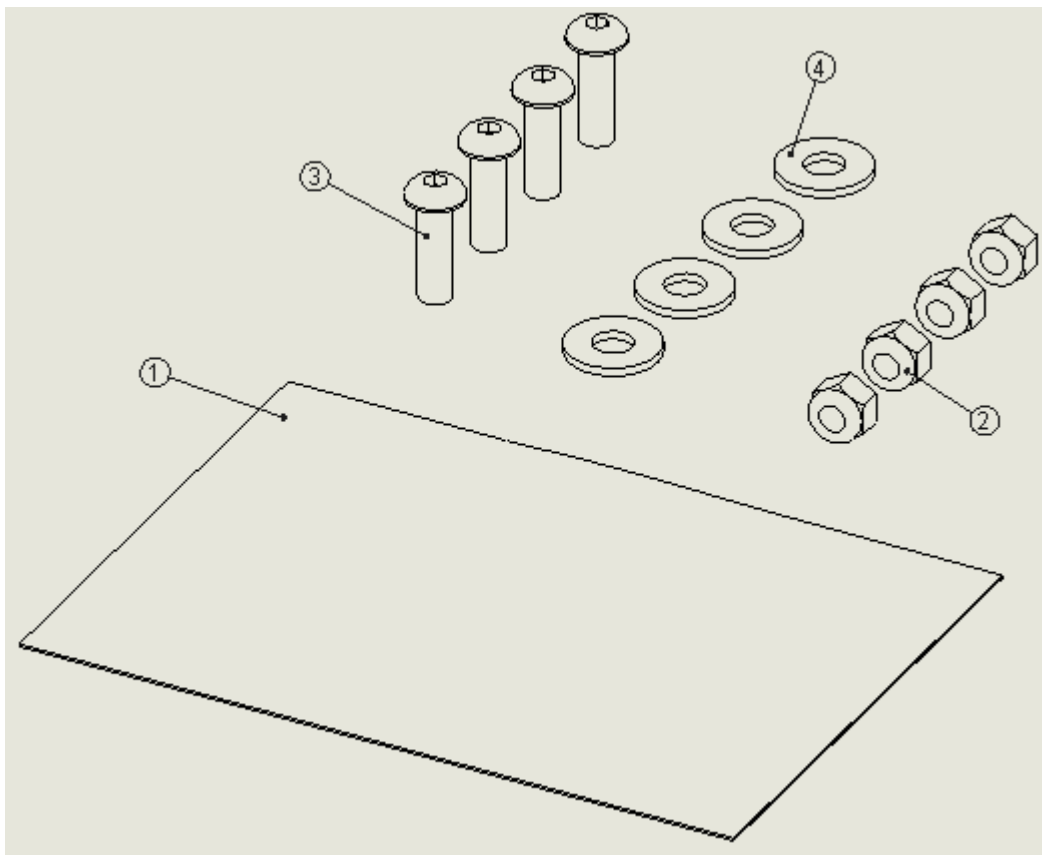

**STEP #1 : ASSEMBLE CONDUIT CARRIER**

**CUT PVC PIPE TO LENGTH. ENDS MUST BE SQUARE WITHIN +/- 1/16". CUT APPROX 6" LONGER THAN WHAT YOU WILL BE CARRYING. NOTE: ON FULL SIZE VANS, CROSS BOWS ARE TYPICALLY SPACED 7' ON CENTER. CONDUIT CARRIER NEEDS TO BE LONG ENOUGH TO REACH BEYOND BOWS AND EXTEND TO NEAR THE REAR END OF VAN FOR ACCESS.**

CLEAN PVC ENDS AND INSIDE END CAPS. MUST BE FREE OF OIL, DIRT, AND BURRS. APPLY SILICONE ADHESIVE TO BOTH THE OUTSIDE OF PVC AND INSIDE OF END CAPS. ASSEMBLE END CAPS ON TO PIPE. DRILL 4 HOLES IN EACH END USING HOLES IN END CAP AND LID ASM AS GUIDES. RIVET TOGETHER AS SHOWN USING RIVET TOOL FOR 5/32" MANDREL. REMOVE EXCESS SILICONE. CURES FULLY IN 24 HOURS.

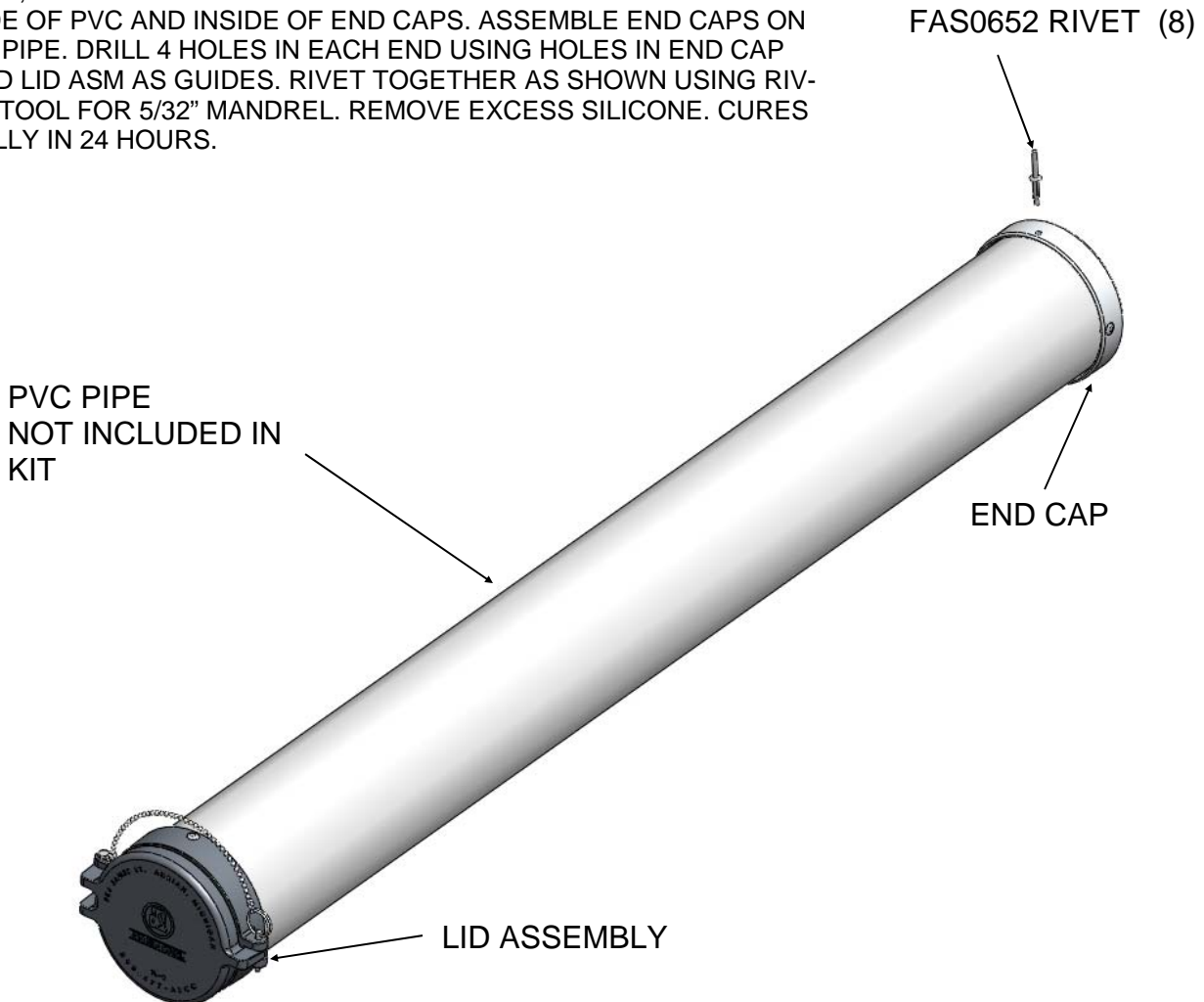



CROSS BOW OF ADRIAN STEEL  
LADDER RACK 70-1 / 70-2

CONDUIT CARRIER KIT

U-BOLT (2)

FAS0104 WASHER AND  
FAS0110 LOCKNUT  
TIGHTEN TO 20 FT LBS TORQUE.  
4 PLACES.

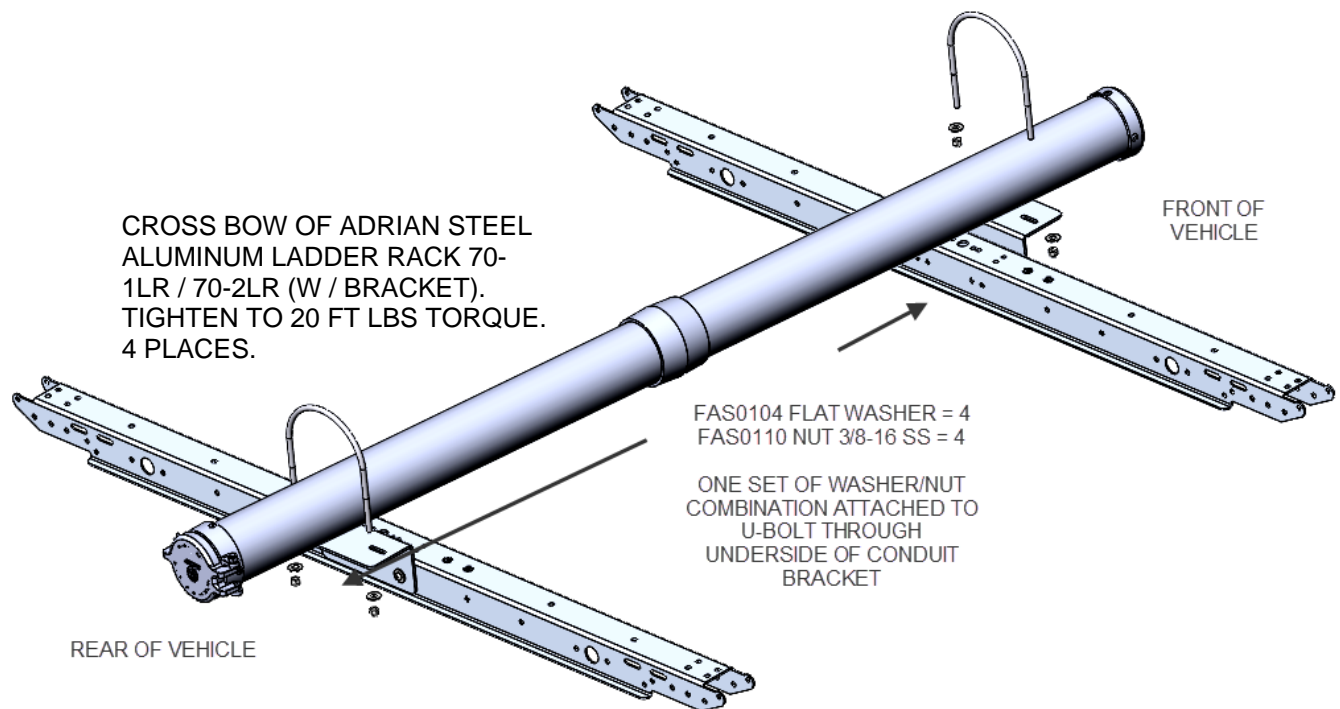

TYPICAL INSTALLATION ON ADRIAN STEEL LADDER RACKS.



**DOUBLE-CHECK ALL FASTENER LOCATIONS TO  
BE SURE THAT ALL FASTENERS ARE TIGHTENED  
TO SPECIFICATIONS!**

