

Introduction / Comments:

Instructions for step ladder bracket. Used for step ladders on full size ladder racks.

Note:

It is advised that all fasteners used in this assembly and installation should be checked for tightness at the following intervals: @ 2-weeks and again @ 6-weeks of operation. This preventive maintenance step must be completed to ensure your Product gives you long service life.

SEE THE "ADJUSTMENT" PAGE IN INSTRUCTIONS I-25535, I-25536, or I-25537 TO HELP SELECT THE MOUNTING LOCATION AND TO RE-ADJUST THE FRONT STOP POST.

Tools Needed:

7/16 wrench and deep well socket with ratchet

9/16 wrench or deep well socket with ratchet

STEP 1: Select the mounting location for the support kit.

(THIS SHOULD BE BASED ON THE LENGTH OF THE LADDER YOU INTENDED TO CARRY)

STEP 2: Attach the OUTER RAIL BRACKET to the OUTER RAIL aligned with the mounting location you selected.

Using FAS0102(2), FAS0104 (2) and FAS0110 (2)

STEP 3: 3a. Now attach the BRACKET to the OUTER RAIL BRACKET on the outer edge. FAS0213 (2) and

FAS0125 (2). **3b** Hand wrap the bracket over the rail and secure in place. FAS0213 (2) and FAS0125(2)

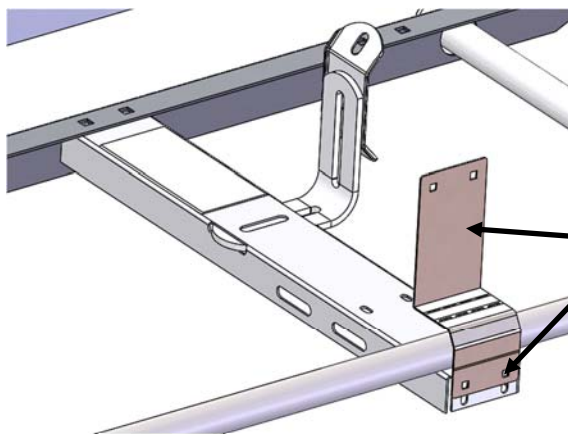

STEP 3a: ATTACH THIS SIDE FIRST

STEP 3b: OUTER RAIL BRACKET HAND WRAP OVER AND SECURE TO ATTACH SECOND

Below is reference for fastener / hardware positions

RAIL GOES HERE

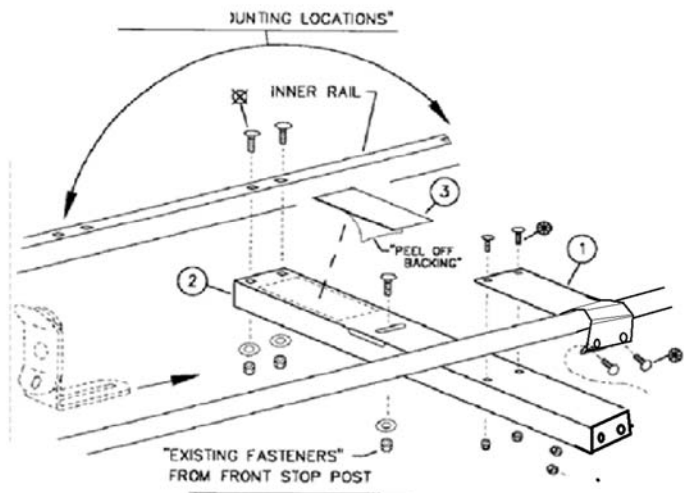

25709-0