



PRODUCT WEIGHT

**49 Lbs**

WIDTH x DEPTH x HEIGHT

**62" x 85" x 8"**

CAPACITY

**24' Extension Ladders  
Or 120 Lbs  
See Below**

COLOR

**Aluminum & Black**

CATALOG NUMBER

**63-PMC**

**PRODUCT FEATURES**

**LIGHTWEIGHT, DOUBLE GRIP-LOCK LADDER RACK FOR THE DODGE PROMASTER CITY VAN. CAN CARRY UP TO 12' STEP LADDERS AND 24' EXTENSION LADDERS. CAPACITY OF 2 LADDERS. ALUMINUM CONSTRUCTION WITH COMPOSITE SURFACES TO PREVENT DAMAGE TO LADDERS AND STAINLESS STEEL FASTENERS. NO DRILL INSTALLATION! ATTACHES TO FACTORY INSTALLED MOUNTING FASTENERS.**

**SEE PAGE 2 FOR APPLICATION NOTES AND ACCESSORIES, OTHER PRODUCTS THAT WORK WITH THIS UNIT.**

**PAGE 1 of 2**

The information contained in this document is the sole property of ADRIAN STEEL COMPANY. ADRIAN STEEL COMPANY retains the right to modify and/or change the product of its design at any time without prior notification.



**CATALOG NUMBER 63-PMC**

***PRODUCT APPLICATION***

**THIS PRODUCT IS DESIGNED SPECIFICALLY FOR THE DODGE  
PROMASTER CITY**

***ACCESSORIES THAT WILL WORK WITH THIS PRODUCT***

***CATALOG NUMBER***

***DESCRIPTION***

**1BPMCGL**

**CENTER BOW ADD-ON KIT FOR CARRYING  
SHORT LADDERS**

***SPECIAL APPLICATION NOTES***

**Additional accessories may be compatible with this product.  
Please consult with ADRIAN STEEL ENGINEERING to review  
specific applications not listed here.**



### Introduction / Comments:

THIS LADDER RACK IS DESIGNED TO MOUNT TO THE FACTORY ATTACHMENT POINTS. REMOVE PLASTIC PLUGS TO INSTALL NEW RACK.

THIS RACK IS DESIGNED FOR AND RATED TO CARRY UP TO 24' EXTENSION LADDERS OR 115 LBS EVENLY DISTRIBUTED ON THE RACK. BE SURE ANY LOAD OR LADDER IS PROPERLY SECURED TO THE RACK PRIOR TO MOVING VEHICLE.

INSTALLATION OF THIS RACK DOES **NOT** ACCOMMODATE USE OF SUNROOF!!!

**NOTE : THIS RACK UTILIZES SPECIFIC STREET AND CURB SIDE ROOF RAILS AND OUTER RAILS!!!**

**Note:**

It is advised that all fasteners used in this assembly and installation of this Rack should be checked for tightness at the following intervals: @ 2-weeks and again @ 6-weeks of operation. This preventive maintenance step must be completed to ensure your package gives you long service life.

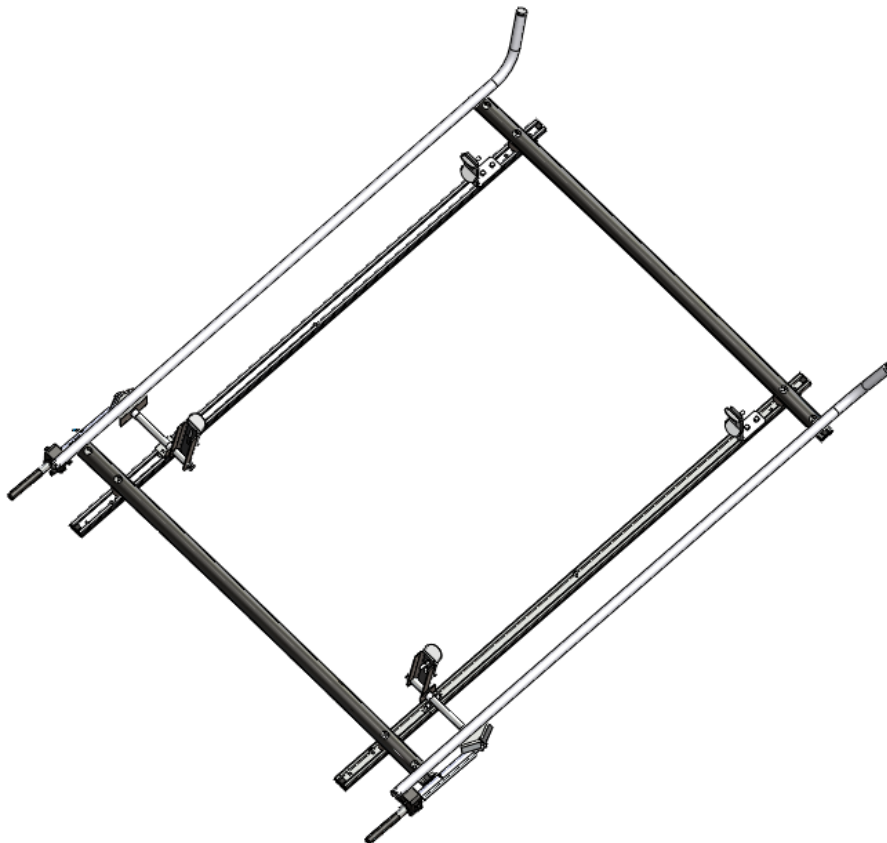

## **63-PMC DOUBLE GRIP-LOCK LADDER RACK ASM FOR DODGE PROMASTER CITY CARGO VAN**



## - PRECAUTIONS -



**CAUTION**  
THE USE OF AIR IMPACT TOOLS CAN  
OVER-TORQUE FASTENERS AND  
CAUSE FASTENER FAILURE!



**CAUTION**  
ALL INSTALLATION HOLES SHOULD BE SEALED  
WITH SILICON OR BUTYL SEALANT TO PREVENT  
EXHAUST FUMES FROM ENTERING THE VEHICLE!



**DANGER**  
INSPECT FOR FUEL TANK, FUEL LINES, BRAKE LINES, HIGH  
VOLTAGE BATTERIES AND ELECTRICAL LINES PRIOR TO  
DRILLING TO AVOID DAMAGING CRITICAL VEHICLE SYSTEMS  
OR INJURY TO INSTALLER DURING INSTALLATION PROCESS!



**CAUTION**  
TO AVOID DAMAGING THE VEHICLE ALWAYS  
USE DRILL STOPS WHEN DRILLING ANY IN-  
STALLATION HOLES!



## - IMPORTANT WARRANTY REQUIREMENTS -

1. SUBSTITUTING ADRIAN STEEL SPECIFIED FASTENERS FOR ASSEMBLY AND/OR INSTALLATION WILL VOID YOUR PRODUCT WARRANTY.
2. ALL HOLES DRILLED INTO VEHICLE SHOULD HAVE THE RAW METAL EDGES SEALED WITH A SELF-ETCHING PRIMER TO RESIST CORROSION AND POTENTIAL FASTENER POINT FAILURE.
3. ALL FASTENERS USED IN THE INSTALLATION OF THIS PRODUCT SHOULD BE TIGHTENED TO THE TORQUE(S) SPECIFIED IN THESE INSTRUCTIONS.
4. THESE INSTRUCTIONS SHOULD BE KEPT WITH THE VEHICLE.

### THE BASIC TOOLS NEEDED FOR MOST INSTALLATIONS



DRILL



DRILL BIT WITH  
STOP



RATCHET, SOCKETS  
AND/OR WRENCHES



SCREWDRIVERS



MEASURING TAPE

ADDITIONAL TOOLS MAY BE NEEDED FOR THIS INSTALLATION AND THEY WILL BE IDENTIFIED IN THE STEPS THAT FOLLOW.



**BAG63PMC  
FASTENER BAG FOR 63-PMC LADDER RACK**

ITEM NO.	PART NUMBER	DESCRIPTION	QTY.
1	35335-0	SLIDE	12
2	36496-0	END CAP	8
3	FAS0698	PIN, SPRING .312X1.50 SS	2
4	FAS0577	Screw, Button Hd Hex Soc, 3/8-16x1.50 NI-ZN	4
5	FAS0830	Screw, Hex Hd, 5/16-18 X 1.25 SS	6
6	FAS 0720	Washer, Flat 3/8 SS	4
7	FAS0110	Nut, Hex Nylk 3/8-16 SS W	4
8	FAS0717	Screw, Hex Hd, 5/16-18x.625 SST	8
9	FAS0740	Shoulder Bolt,	2
10	FAS0234	Washer, Flat, 1/4, SST	12
11	FAS0125	Nut, Nylon Insert Lock, 1/4-20 SST	2
12	FAS0588	Washer, Lock, Split, 5/16, SS	22
13	BAG0709-A	7" x 9" 3MIL AUTOBAG	1
14	FAS0242	Screw, Hex Hd, 5/16-18x1.50 Stainless Steel	4
15	FAS0243	Screw, Hex Hd, 5/16-18x2.50 Stainless Steel	4
16	FAS0552	Washer, Flat, 5/16, SST	22
17	FAS0672	Washer, Lock, Split, 1/4", SST	10
18	FAS0315	Screw, Button Hd Hex Soc, M6-1 X 30 mm lg, SST	10

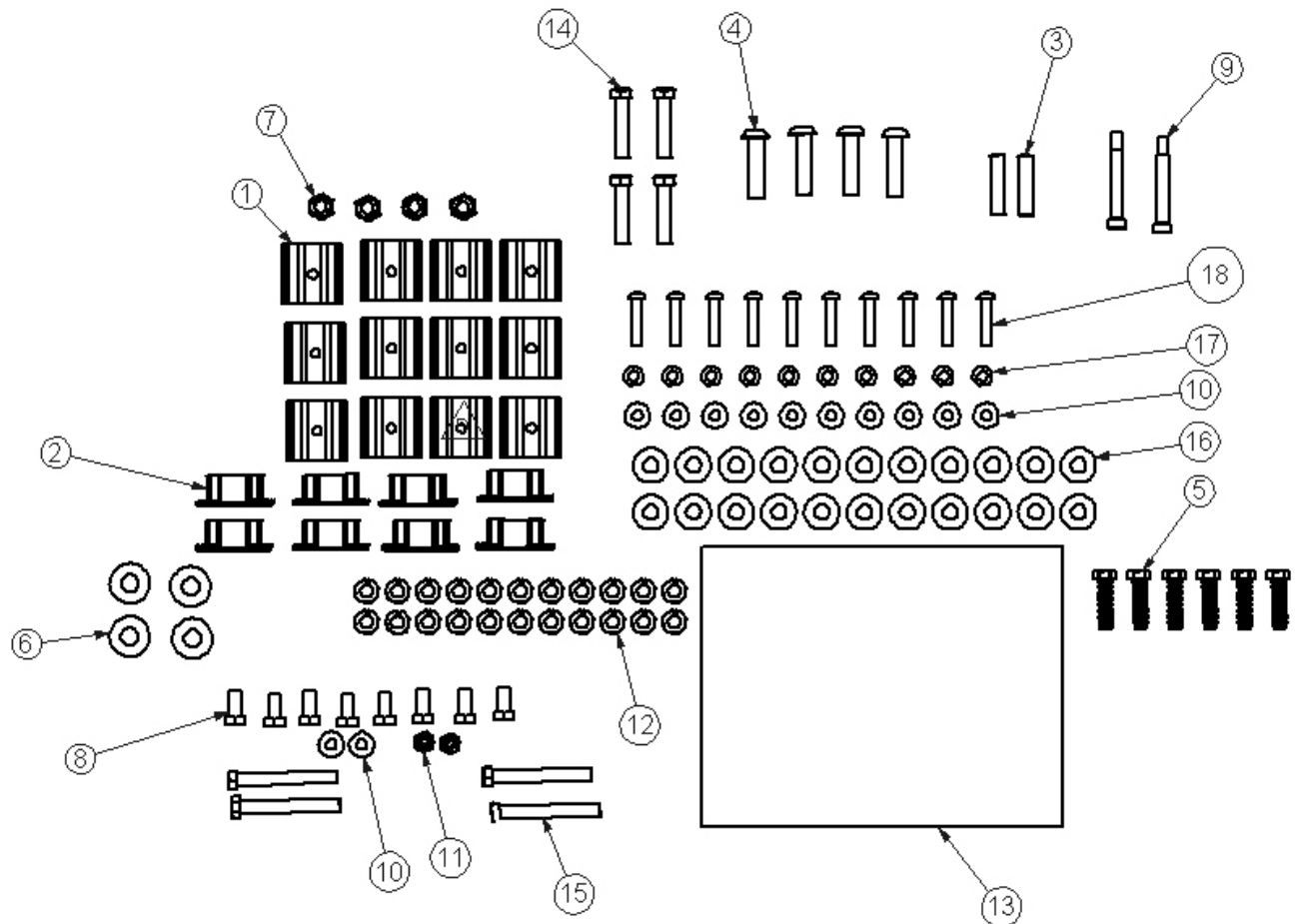



BAG45260 ACCESSORY BAG FOR 63-PMC

ITEM NO.	PART NUMBER	DESCRIPTION	BAG45260/QTY.
1	38846-B	BUSHING, G/L, TC	4
2	37517-0	End Cap, Black	4
3	51363	CAP PLUG, RND, BLK, 1 DIA	4
4	BAG0507-A	5' x 7' 3MIL AUTOBAG	1
5	28818-0	Silicone Sealant	1
6	05586-0	Butyl Tape, T224 -1/2"X 1' Roll	2

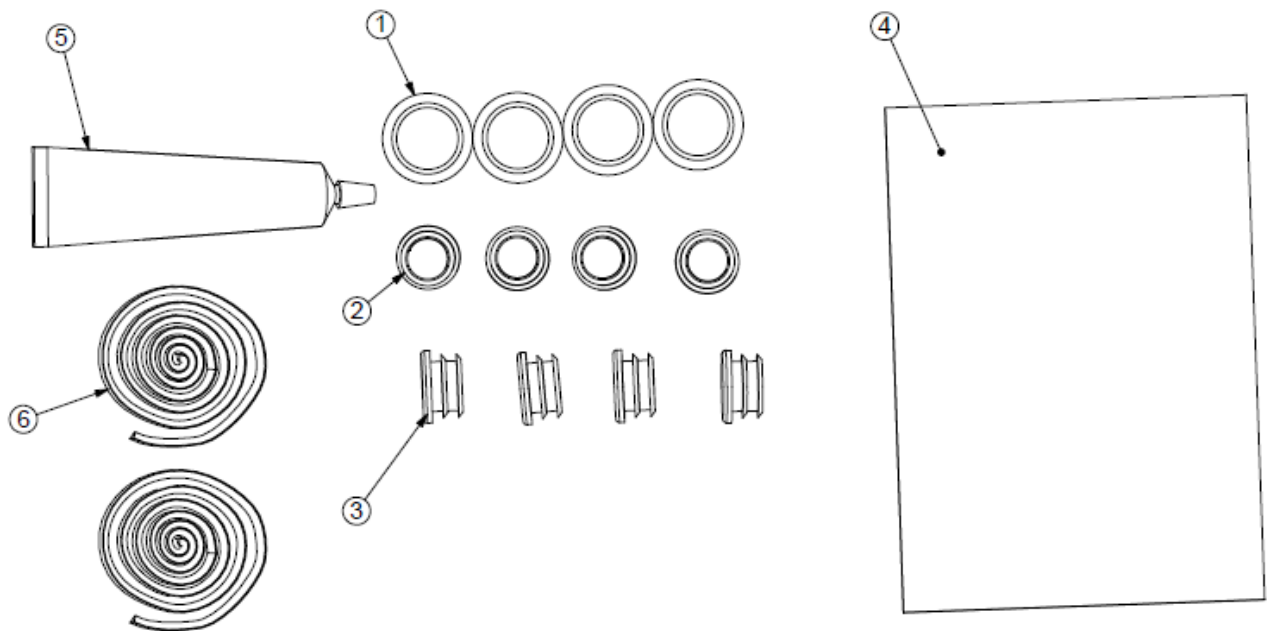



**STEP #01: ASSEMBLE ROOF RAILS. NOTE DIFFERENCES BETWEEN STREET AND CURB SIDE ROOF RAILS!!**

**INSERT (6) 35335-0 SLIDES INTO EACH ROOF RAIL AND (1) 36496-0 END CAP INTO EACH END (4 TOTAL). PEEL AND STICK FOAM STRIP TO BOTTOM OF EACH RAIL.**

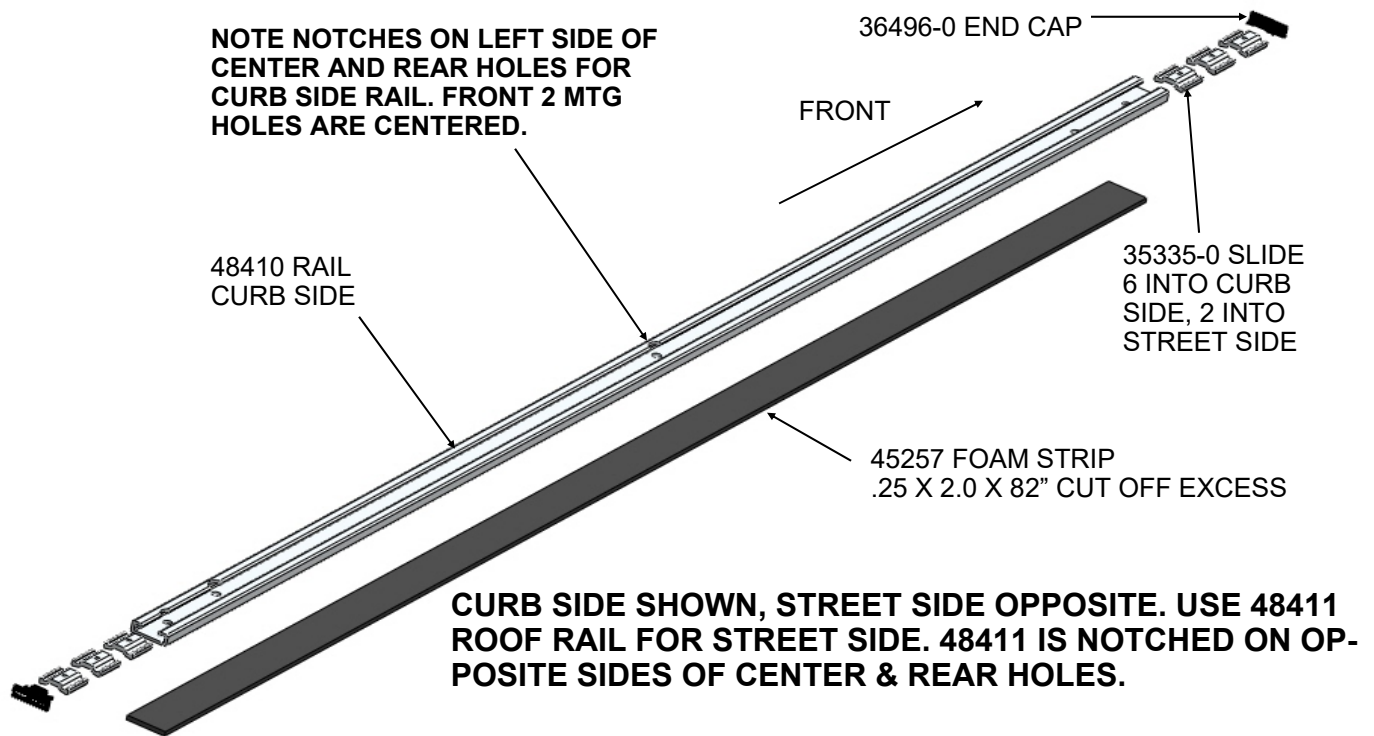

**STEP #02 : ASSEMBLE 2 CROSS BOW ASMs.**

**SLIDE WEAR INSERT INTO CROSS BOW UNTIL INNER HOLES LINE UP ON EACH END. INSERT (1) 36496-0 END CAP INTO EACH END OF EACH BOW ASM. TIP : BEND WEAR INSERT TO MATCH CURVATURE OF BOW WHILE INSERTING. SOME MATERIAL WILL SHAVE OFF AS THIS IS AN INTERFERENCE FIT!**

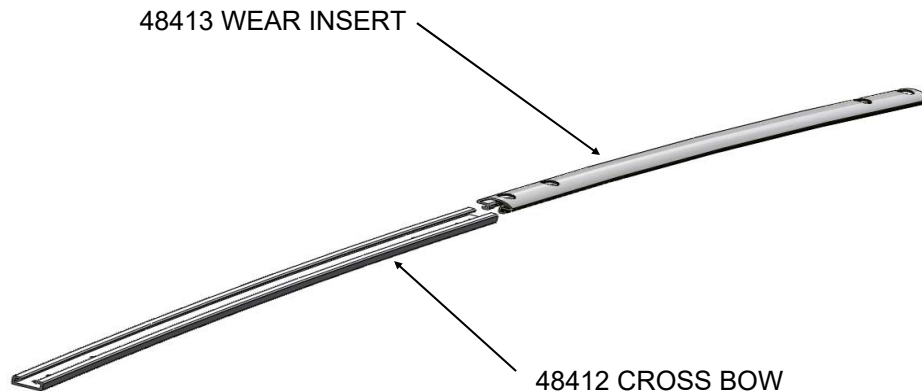



**STEP #03 : ASSEMBLE LADDER STOPS TO ROOF RAILS, 1 EACH RAIL**

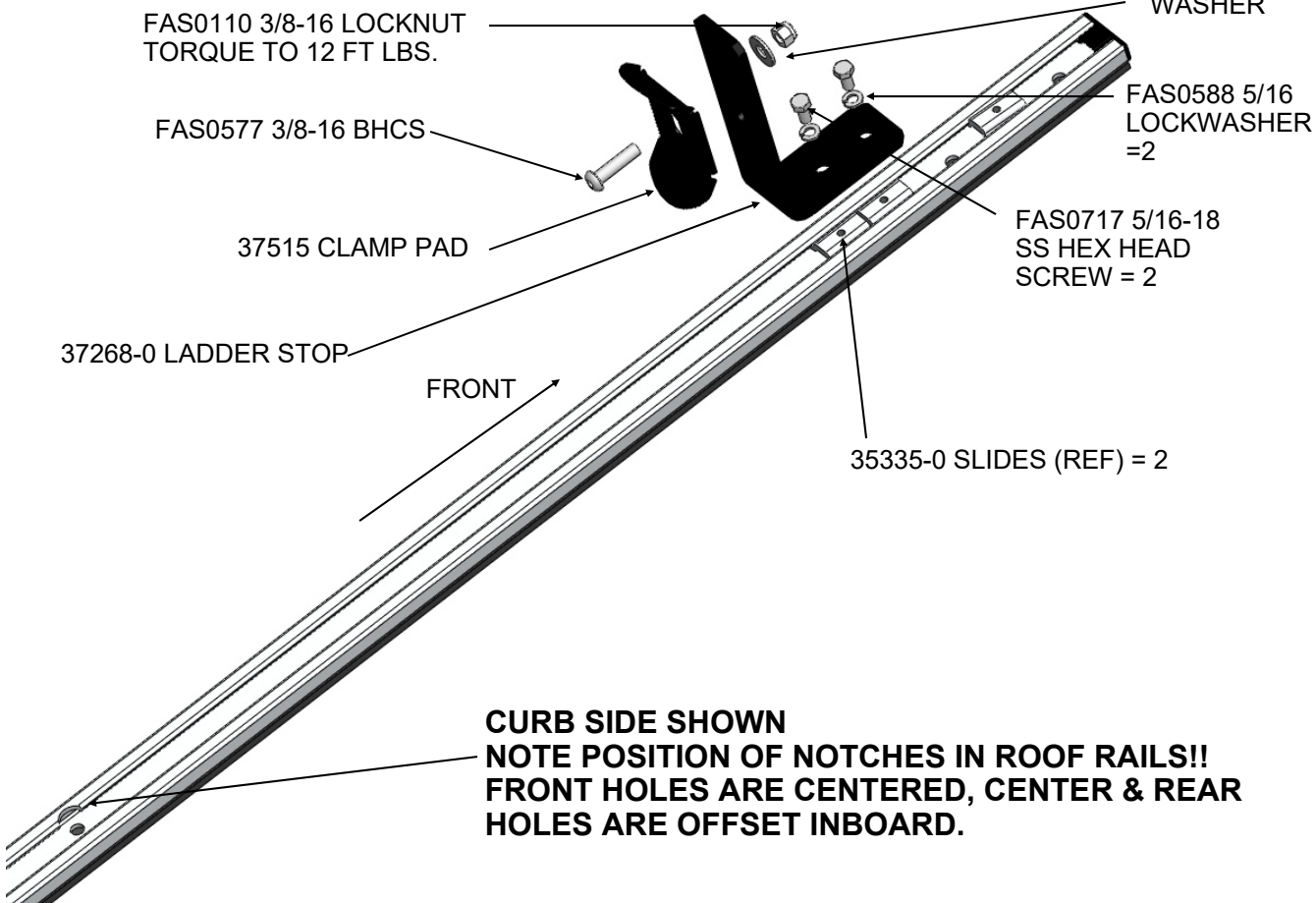

**STEP #04 : ASSEMBLE BOW ASMS TO ROOF RAILS**

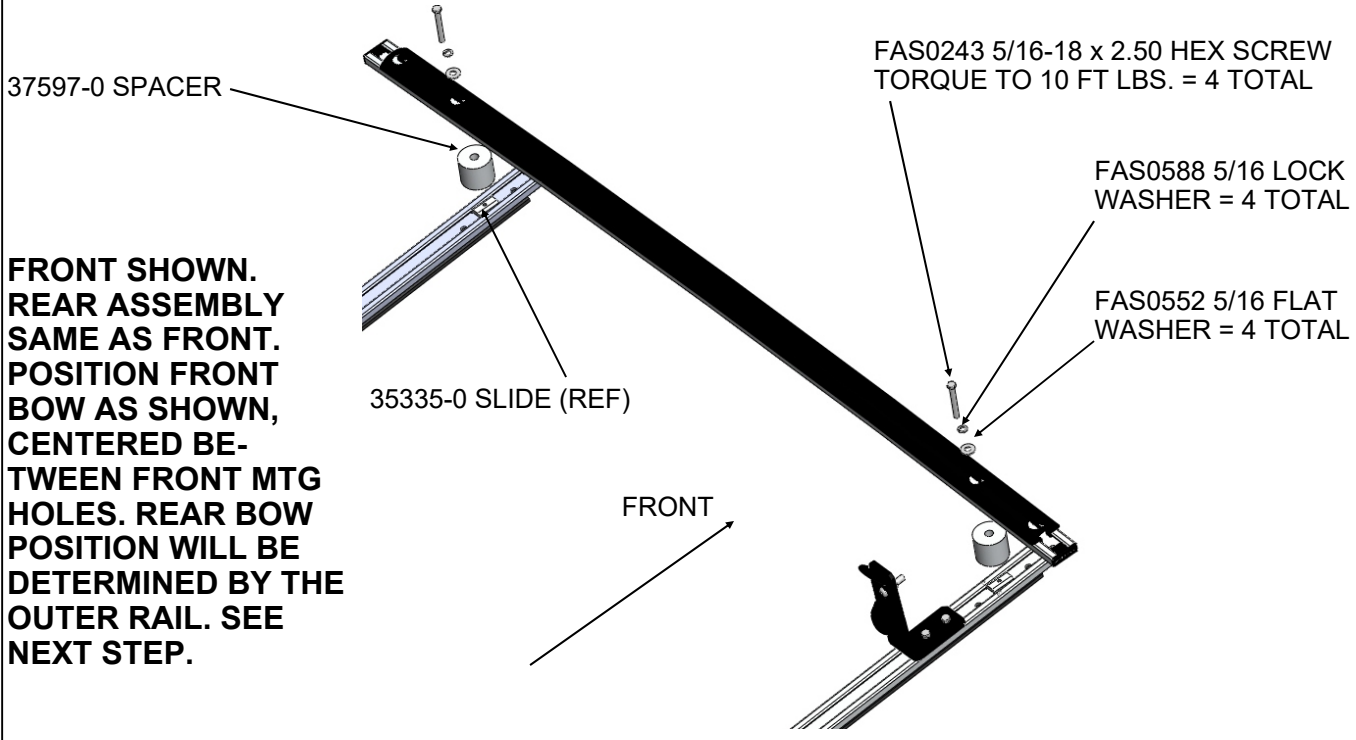





**STEP #05 ASSEMBLE OUTER RAILS TO RACK**

INSTALL (2) 51363 END CAPS INTO TUBE ENDS, INSTALL LATCH ASM AS SHOWN AND INSTALL ASM ON RACK.

**NOTE : OUTER RAILS HAVE  
5/16 RIVNUTS IN BOTTOM SIDE  
FOR ATTACHMENT.**

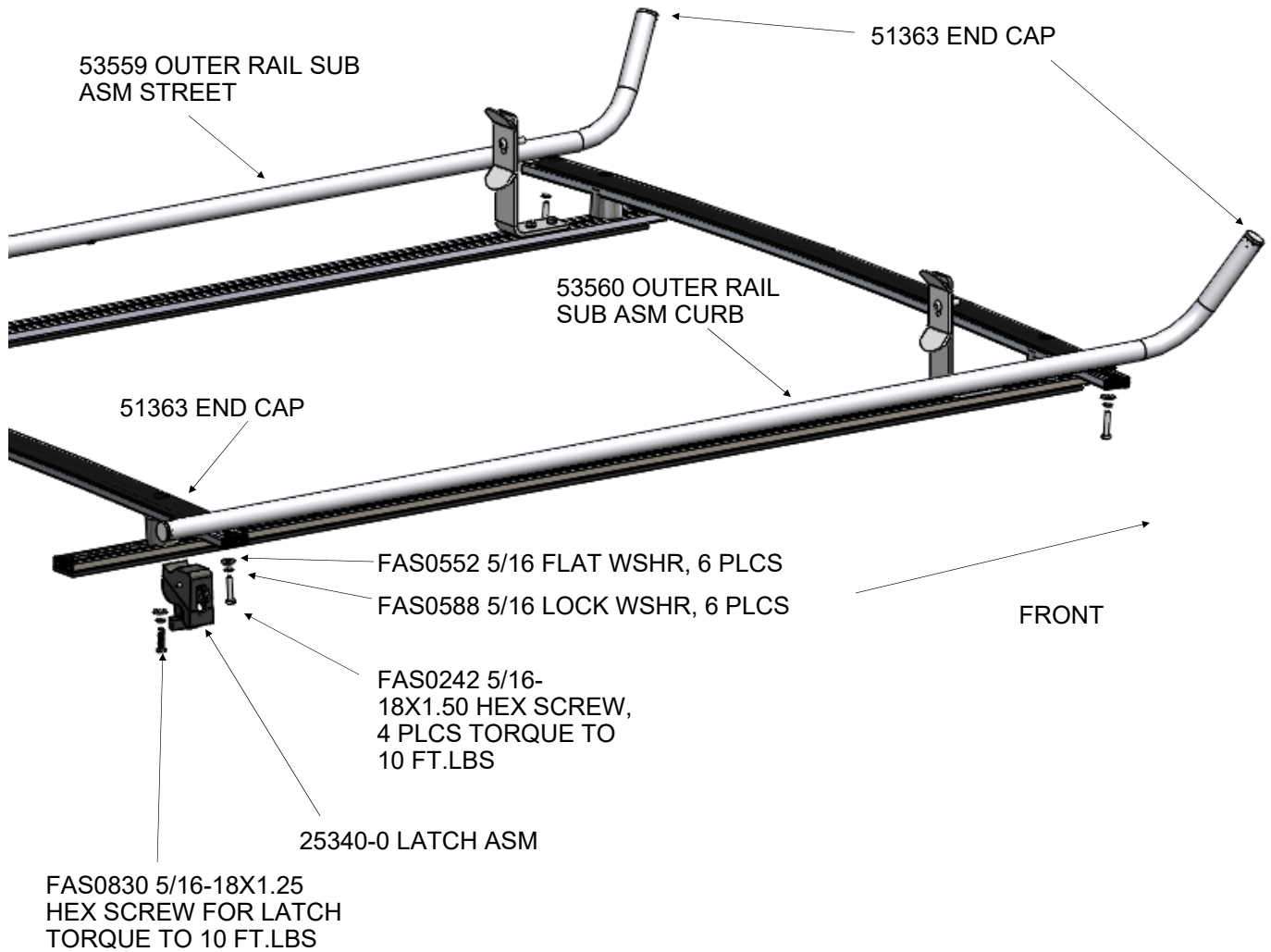



**STEP #06 ASSEMBLE GRIP-LOCK MECHANISM AND INSTALL ON RACK**

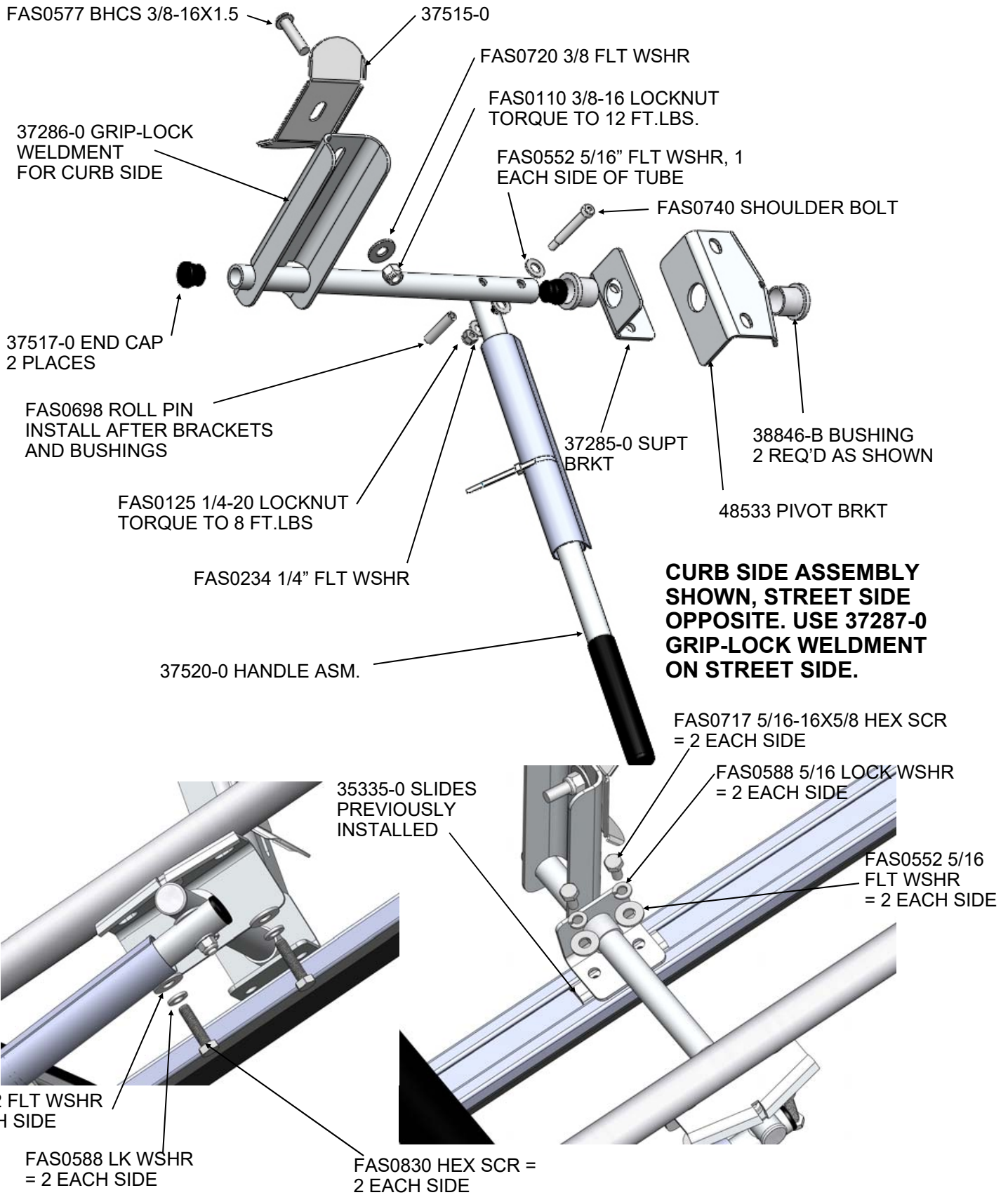



**STEP #07 ASSEMBLE GRIP-LOCK RACK TO VEHICLE**

REMOVE OEM PLASTIC PLUGS (10) FROM ROOF. THESE ARE THE ATTACHMENT POINTS FOR THE RACK. POSITION THE RACK ON ROOF, ADD THE SPACERS AND SCREW THE FAS0315 SCREWS INTO THE OEM

FASTENERS IN ROOF AFTER APPLYING SOME BUTYL TAPE UNDER WASHERS (SEE VIEW BELOW). TORQUE AS SHOWN. FASTENERS SHOWN BELOW ARE TYPICAL AT ALL ATTACHMENT POINTS.

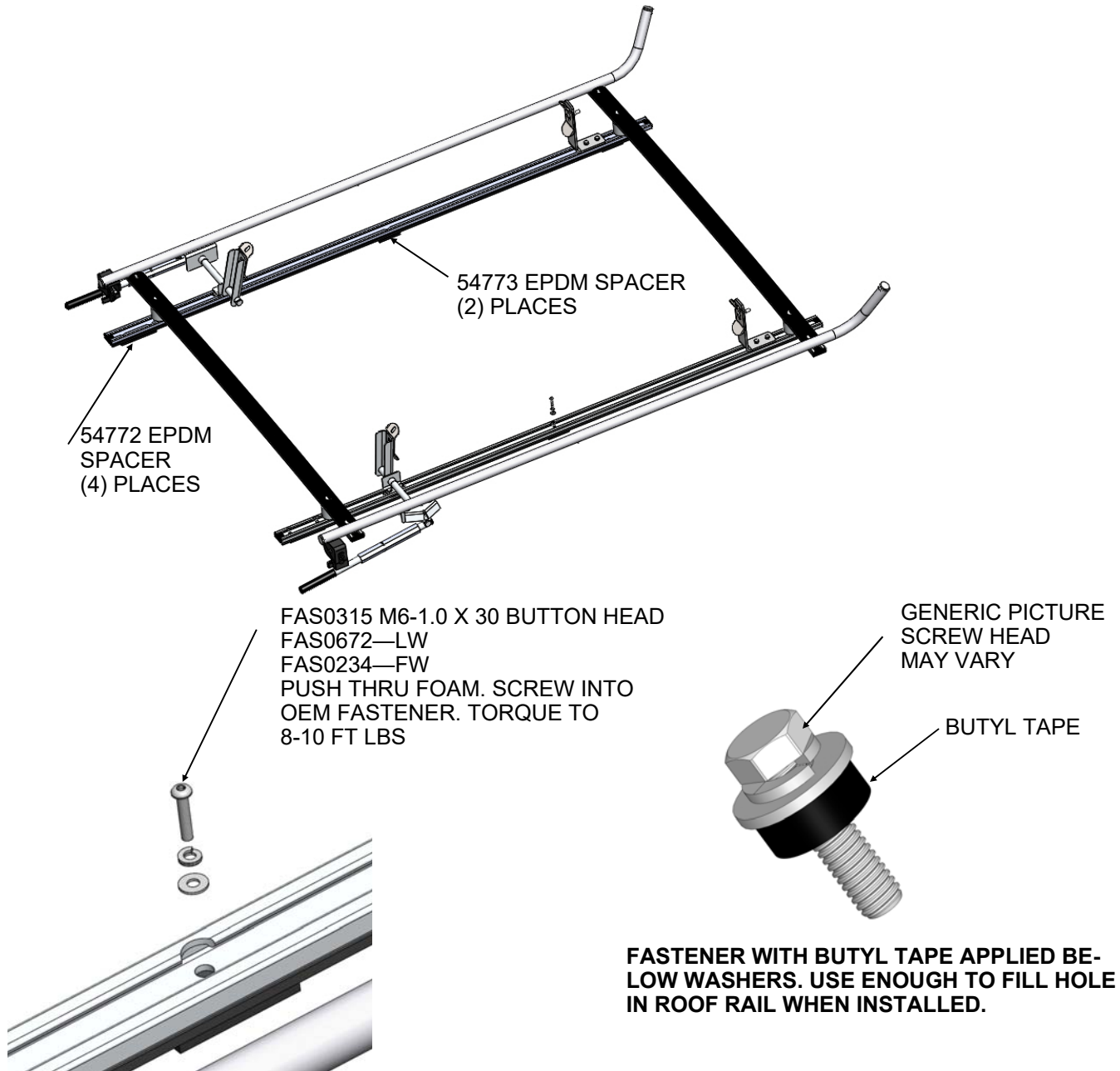

**DOUBLE-CHECK ALL FASTENER LOCATIONS TO BE SURE THAT ALL FASTENERS ARE TIGHTENED TO SPECIFICATIONS!**

