



## “Grip Lock” Ladder Rack Assembly & Installation Instructions

### 7' LADDER RACKS – FULL SIZE VAN (FORD & GM )

Dodge – LDF4 Foot Kit is required to install these racks and it is ordered separately.

**61-1**  
**61-1B**

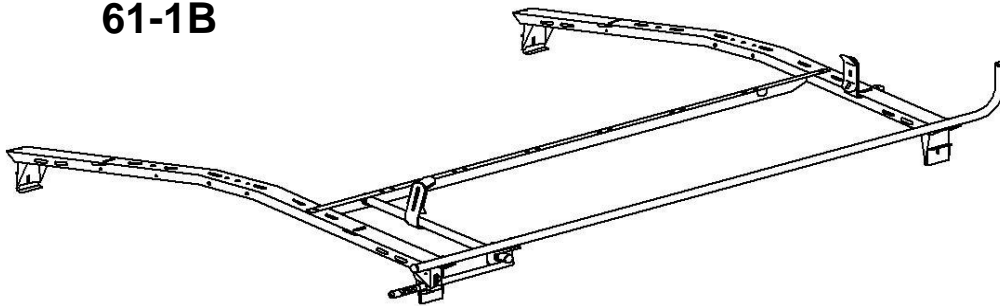

**63-1**  
**63-1B**

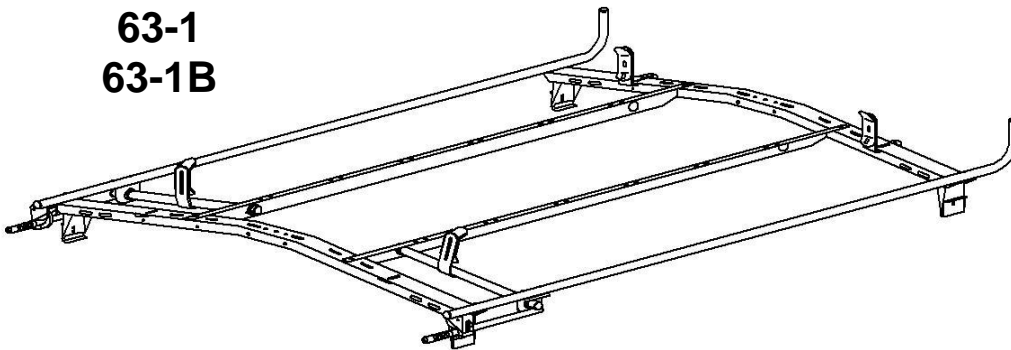

**61-1 LDRK, WHT, 7' Single, Full Size Van**  
**61-1B LDRK, BLK, 7' Single, Full Size Van**

**63-1 LDRK, WHT, 7' Double, Full Size Van**  
**63-1B LDRK, BLK, 7' Double, Full Size Van**

P/N: 25535-0

ISSUE: G

CHK.BY: \_\_\_\_\_

REV.BY: \_\_\_\_\_

DWG.BY: DCS

ECN- 21094



# “GRIP LOCK” Ladder Rack

## BEFORE YOU START!

IMPORTANT INSTALLATION STEPS ARE DENOTED USING A STOP SIGN. THESE STEPS MUST BE PERFORMED AS SPECIFIED IN ORDER TO ENSURE A PROPER INSTALLATION AND MUST BE FOLLOWED IN ORDER TO MAINTAIN YOUR PRODUCT WARRANTY!



CRITICAL INFORMATION PERTAINING TO USER AND/OR VEHICLE SAFETY IS DENOTED USING A CAUTION SIGN. SAFETY ITEMS MUST BE STRICTLY ADHERED TO IN ORDER TO ENSURE A SAFE WORKING ENVIRONMENT!



YOU WILL NEED THE FOLLOWING TOOLS IN ORDER TO COMPLETE THIS JOB.

7/16', 9/16', & 5/8" Combination End Wrenches and Deepwell Sockets w/Ratchet  
1/8" Ball End Allen Wrench, Hammer, Framing or Machinist Square, Tape Measure

ALL FASTENERS USED IN THE ASSEMBLY AND INSTALLATION OF THIS PRODUCT SHOULD BE TIGHTENED TO THE SPECIFIED TORQUE AS LISTED WITH EACH FASTENER CALLOUT BOX.



THE USE OF AIR OR ELECTRIC IMPACT TOOLS FOR THE ASSEMBLY OF FASTENERS IS NOT RECOMMENDED AND COULD CAUSE FASTENER FAILURE!



## WARNING



THE USE OF DRILLS WITH INTEGRAL DRILL STOPS ALONG WITH PROPER INSPECTION FOR GAS TANK, GAS LINES, BRAKE LINES AND ELECTRICAL LINES PRIOR TO DRILLING ANY MOUNTING HOLES IS STRONGLY RECOMMENDED TO ENSURE THAT VEHICLE DAMAGE IS AVOIDED!



THE USE OF NON-STANDARD FASTENERS AND/OR DEVIATING FROM THE FASTENERS SPECIFIED IN THE INSTRUCTION (S) MAY VOID YOUR PRODUCT WARRANTY!



ALL DRILLED HOLES IN THE VEHICLE SHOULD HAVE THE RAW METAL EDGES SEALED WITH A SELF-ETCHING PRIMER TO RESIST CORROSION AND POTENTIAL FASTENER POINT FAILURE!



**TO PREVENT EXHAUST FUMES FROM ENTERING THE VEHICLE,  
ALL HOLES SHOULD BE SEALED AT INSTALLATION WITH  
BUTYL OR SILICON SEALANT MATERIAL.**



Whenever a plusnut is specified it is important that the proper size installation hole is provided.

PLUSNUT SIZE		DRILL SIZE <i>(with stop)</i>
1/4-20 PLUSNUT, FAS0052		3/8" DIAMETER
5/16-18 PLUSNUT, FAS0091		1/2" DIAMETER

## FOR MOUNTING THROUGH A FLOOR MAT AND/OR CARPET

Position each item in desired location inside the vehicle and mark the floor mounting locations.

It is recommended that a drilling template be used to ensure an accurate placement of components is achieved for this installation.

Using the cutting tool, drill a pilot hole thru the mat/carpet and metal floor pan.

### Spacer Use and Installation

3927-1 (SHOWN)

ALWAYS PLACE RECESSED PART OF FLOOR SPACER ON TOP OF PLUSNUT.

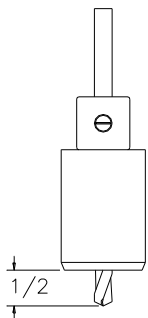

Placing the properly sized spacer on top of the vehicle floor pan will make your Adrian interior level, square, and sound. The view below shows the proper sized spacer for the different heights of the vehicle floor. Make sure to place the spacers with the plusnut relief surface down as shown.

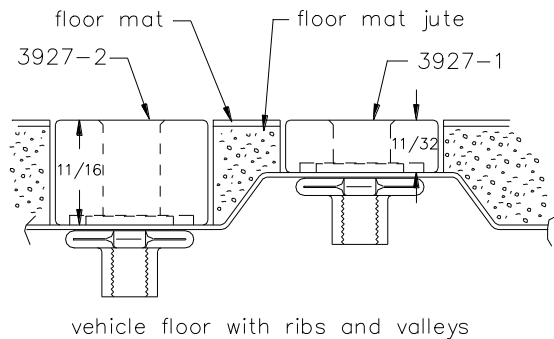
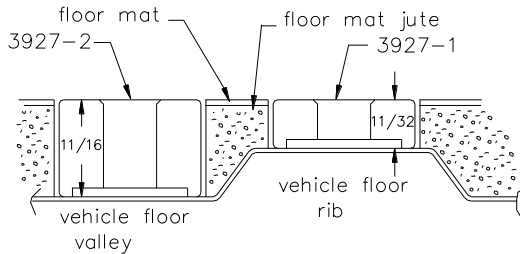

The location of various floor mounts will determine what spacer combination will be used. For example, an 11/32" spacer is used atop floor ribs, and an 11/16" high spacer is used atop floor valleys.



**THE PROPER USE OF SPACERS IS REQUIRED WHEN MOUNTING OVER MAT/CARPET TO ENSURE THE METAL-TO-METAL CLAMP-UP, WHICH WILL PREVENT UNWANTED COMPONENT SHIFTING AND POTENTIAL FAILURE DURING USE.**









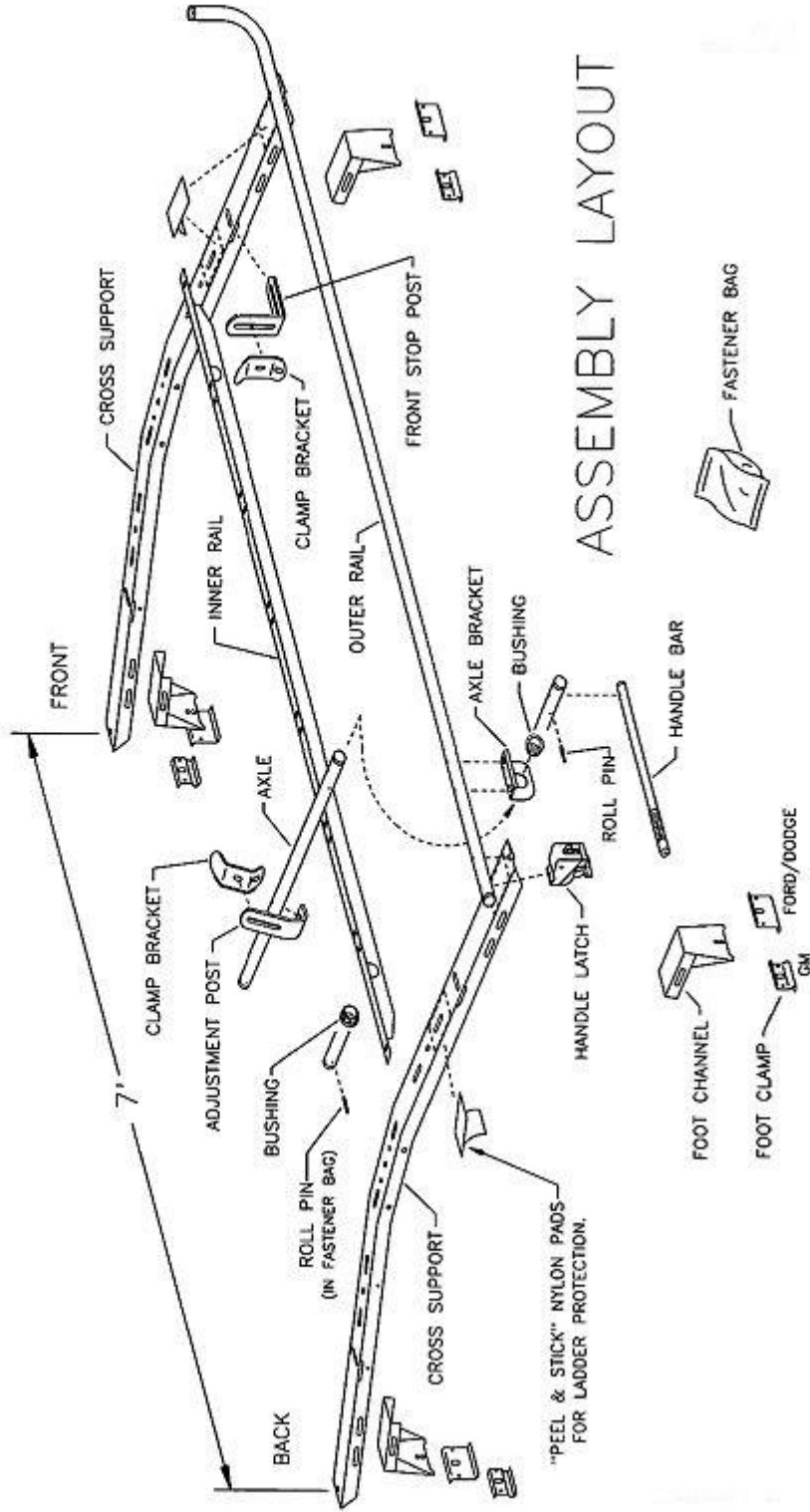

























# “GRIP LOCK” Ladder Rack

**BEFORE YOU BEGIN:**  
 REFER TO THE COVER PAGE (PAGE-1), ASSEMBLY LAYOUT (PAGE-2), PARTS LIST (PAGE-3), & FASTENER TEMPLATE (PAGE-4) TO PROPERLY IDENTIFY THE PARTS IN THE BOX FOR YOUR LADDER RACK. A "61-1 SINGLE" IS SHOWN BELOW, SOME PARTS ARE DUPLICATED TO THE OTHER SIDE OF THE LADDER RACK TO MAKE A "63-1 DOUBLE" (SEE COVER PAGE).  
 \* PLEASE READ THROUGH & FOLLOW EACH STEP CAREFULLY TO EASE THE ASSEMBLY & INSTALLATION OF YOUR LADDER RACK. \*  
 IF YOU HAVE ANY QUESTIONS OR COMMENTS PLEASE CONTACT THE DEALER YOU PURCHASED YOUR LADDER RACK FROM OR CALL US AT ADRIAN STEEL Co. (800) 677-2726 . THANK YOU FOR CHOOSING THE ADRIAN STEEL Co. "GRIP LOCK" LADDER RACK !



































**FASTENER & COMPONENT HARDWARE**

61-1 “LADDER RACK, 7’ SINGLE, FULL SIZE VAN”			
PART NUMBER	PART DESCRIPTION	QTY REQ'D	PART IMAGE
FAS0058	NUT, NYLON LOCK, ¼-20UNC	1	
FAS0100	NUT, HEX FLANGE, SS, 3/8-16UNC	15	
FAS0102	BOLT, CARRIAGE, ZN G5, 3/8-16UNC X 1.00”	13	
FAS0104	WASHER, FLAT, ZN-NI, 3/8” ID	19	
FAS0110	NUT, NYLON LOCK, SS, 3/8-16UNC	8	
FAS0117	BOLT, CARRIAGE, ZN G5, 3/8-16UNC X 1.50”	4	
FAS0124	WASHER, FLAT, ZN-NI, 1/4” ID	2	
FAS0139	WASHER, FLAT, ZN, ½” ID	4	
FAS0184	BOLT, CARRIAGE, ZN G5, 3/8-16UNC X 2.00”	1	
FAS0204	BOLT, CARRIAGE, ZN G8, 3/8-16UNC X 1.75”	4	
FAS0212	PIN, SPRING, SS, ¼” OD X 1.375”	2	
FAS0239	BOLT, CARRIAGE, ZN-NI, G8, 3/8-16UNC X 1.875	1	
07466-0	NUT, ADJUSTING CAM	4	
10103-0	WASHER, FLAT, B-NYLON, 7/16”ID X 13/16”OD	1	
17976-0	BOLT, SHOULDER, 5/16-18UNC, ¼”OD X 2.25”	1	
05586-0	TAPE, BUTYL, T224	1	
09677-0	BUSHING, TUBE, 1.25”	2	
09704-0	POST, ADJUSTMENT, 8”	1	
11427-0	FOOT CLAMP, DIRP RIAL, WHT, (FORD/DODGE)	4	
16024-0	FOOT CHANNEL, 4-3/8”	4	
22856-0	FOOT CLAMP, GMT600, WHT (GM)	4	
25329-0	OUTER RAIL, 7’ LDRK, FSV, WHT	1	
25332-0	INNER RAIL, 7’ LDRK, FSV, WHT	1	
25335-0	CROSS SUPPORT, 70” FSV, WHT	2	
25337-0	AXLE 1.25” OD X 26.187” LG, WHT	1	
25338-0	AXLE BRACKET, STD. LDRK, WHT	1	
25340-0	HANDLE LATCH STD LDRK, WHT	1	
25345-0	LADDER PAD STICK ON	4	
37515-0	CLAMP BRACKET, STD. LDRK, WHT	2	
25410-0	HANDLE BAR, GRIPLOCK LDRK, WHT	1	
25497-0	FRONT STOP POST, ADJUSTABLE	1	



**FASTENER & COMPONENT HARDWARE (continued)**

63-1 “LADDER RACK, 7’ DOUBLE, FULL SIZE VAN”			
PART NUMBER	PART DESCRIPTION	QTY REQ'D	PART IMAGE
FAS0058	NUT, NYLON LOCK, ¼-20UNC	2	
FAS0100	NUT, HEX FLANGE, SS, 3/8-16UNC	22	
FAS0102	BOLT, CARRIAGE, ZN G5, 3/8-16UNC X 1.00”	18	
FAS0104	WASHER, FLAT, ZN-NI, 3/8” ID	30	
FAS0110	NUT, NYLON LOCK, SS, 3/8-16UNC	12	
FAS0117	BOLT, CARRIAGE, ZN G5, 3/8-16UNC X 1.50”	4	
FAS0124	WASHER, FLAT, ZN-NI, 1/4” ID	4	
FAS0139	WASHER, FLAT, ZN, ½” ID	4	
FAS0184	BOLT, CARRIAGE, ZN G5, 3/8-16UNC X 2.00”	2	
FAS0204	BOLT, CARRIAGE, ZN G8, 3/8-16UNC X 1.75”	8	
FAS0212	PIN, SPRING, SS, ¼” OD X 1.375”	4	
FAS0239	BOLT, CARRIAGE, ZN-NI, G8, 3/8-16UNC X 1.875	2	
07466-0	NUT, ADJUSTING CAM	4	
10103-0	WASHER, FLAT, B-NYLON, 7/16”ID X 13/16”OD	2	
17976-0	BOLT, SHOULDER, 5/16-18UNC, ¼”OD X 2.25”	2	
05586-0	TAPE, BUTYL, T224	2	
09677-0	BUSHING, TUBE, 1.25”	4	
09704-0	POST, ADJUSTMENT, 8”	2	
11427-0	FOOT CLAMP, DIRP RIAL, WHT, (FORD/DODGE)	4	
16024-0	FOOT CHANNEL, 4-3/8”	4	
22856-0	FOOT CLAMP, GMT600, WHT (GM)	4	
25329-0	OUTER RAIL, 7’ LDRK, FSV, WHT	2	
25332-0	INNER RAIL, 7’ LDRK, FSV, WHT	2	
25335-0	CROSS SUPPORT, 70” FSV, WHT	2	
25337-0	AXLE 1.25” OD X 26.187” LG, WHT	2	
25338-0	AXLE BRACKET, STD. LDRK, WHT	2	
25340-0	HANDLE LATCH STD LDRK, WHT	2	
25345-0	LADDER PAD STICK ON	8	
37515-0	CLAMP BRACKET, STD. LDRK, WHT	4	
25410-0	HANDLE BAR, GRIPLOCK LDRK, WHT	2	
25497-0	FRONT STOP POST, ADJUSTABLE	2	











ALL QUANTITIES SHOWN IN THE FOLLOWING INSTRUCTIONS ARE FOR THE SINGLE LADDER RACK (61-1). AMOUNTS WILL BE DOUBLED IF INSTALLING A DOUBLE LADDER RACK (63-1). PLEASE READ THROUGH AND FOLLOW EACH STEP CAREFULLY TO EASE ASSEMBLY AND INSTALLATION OF YOUR LADDER RACK. IF YOU HAVE ANY QUESTIONS OR COMMENTS PLEASE CONTACT THE DEALER YOU PURCHASE YOUR LADDER RACK OR CALL US AT ADRIAN STEEL. THANK YOU FOR CHOOSING THE ADRIAN STEEL Co. “GRIP LOCK” LADDER RACK



## STEP – 01

## INNER RAIL – OUTER RAIL – CROSS SUPPORT ASSEMBLY

The following fasteners and components are required to complete this step.

 <b>25329-0</b> 7' LDRK FSV, OUTER RAIL	 <b>25332-0</b> 7' LDRK FSV, INNER RAIL	 <b>25335-0</b> 70" FULL SIZE VAN, CROSS SUPPORT (2) REQ'D	 <b>FAS0102</b> 3/8-16UNC X 1.00" CARRIAGE BOLT (2) REQ'D	 <b>25345-0</b> LADDER PAD-STICK ON (4) REQ'D
 <b>FAS0104</b> 3/8" FLAT WASHER (4) REQ'D	 <b>FAS0100</b> 3/8-16UNC HEX FLANGE NUT (4) REQ'D 31 ft-lbs (+/- 2 ft-lbs)	 <b>05586-0</b> 1' ROLL BUTYL TAPE, T224	 <b>FAS0204</b> 3/8-16UNC X 1.75" CARRIAGE BOLT (2) REQ'D	

Attach the INNER RAIL to the front and back CROSS SUPPORTS using 3/8-16UNC x 1" CARRIAGE BOLT, 3/8" FLAT WASHER, 3/8-16UNC HEX FLANGE NUT. (Finger Tighten Only).

Next peel off approximately 1/4" of BUTYL TAPE and evenly wrap it around the bottom side of each 3/8-16UNC x 1.75" lg CARRIAGE BOLT head to seal holes in the OUTER RAIL.

Next attach the OUTER RAIL to the front and rear CROSS SUPPORTS using 3/8-16UNC x 1.75" CARRIAGE BOLT, 3/8" FLAT WASHER, 3/8-16UNC HEX FLANGE NUT. (Finger Tighten Only)

Now square the assembly (INNER RAIL to CROSS SUPPORTS & OUTER RAIL to CROSS SUPPORTS) with a 90 degree framing square and firmly tighten the OUTER RAIL & INNER RAIL fasteners. Remove backing on the LADDER PAD-STICK ON and apply to CROSS SUPPORTS as shown in illustration below.

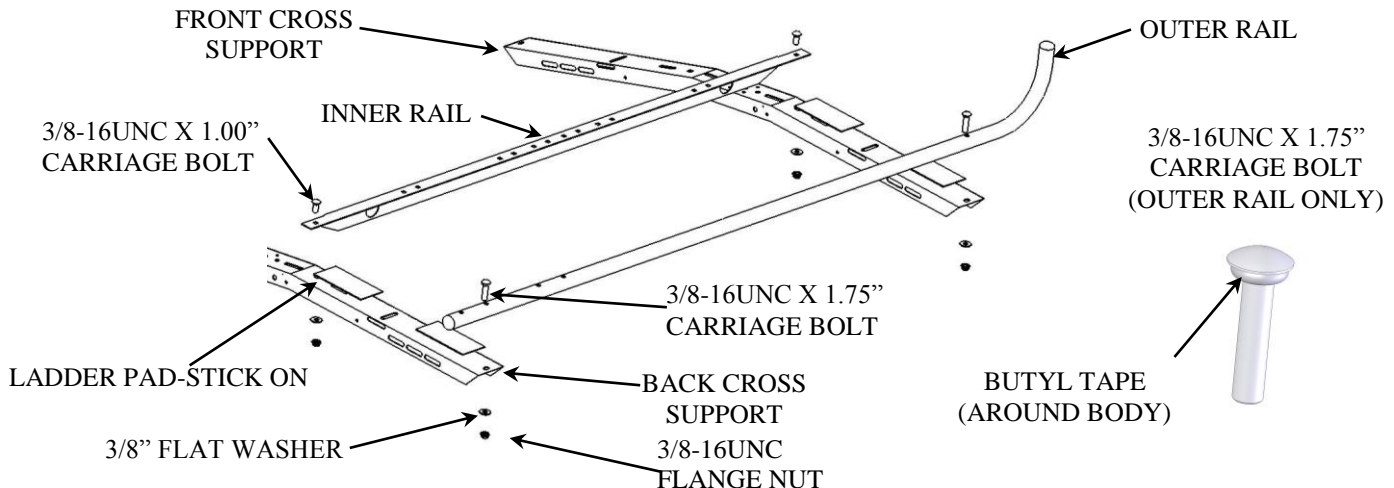



## STEP – 02 HANDLE LATCH – AXLE BRACKET INSTALLATION

The following fasteners and components are required to complete this step.

 <p><b>25340-0</b> HANDLE LATCH</p>	 <p><b>25338-0</b> AXLE BRACKET</p>	 <p><b>FAS0204</b> 3/8-16UNC X 1.75” CARRIAGE BOLT (2) REQ'D</p>	 <p><b>FAS0239</b> 3/8-16UNC x 1.875” CARRIAGE BOLT (1) REQ'D</p>
 <p><b>FAS0104</b> 3/8” FLAT WASHER (2) REQ'D</p>	 <p><b>FAS0100</b> 3/8-16UNC HEX FLANGE NUT (3) REQ'D 31 ft-lbs (+/- 2 ft-lbs)</p>	 <p><b>05586-0</b> 1’ ROLL BUTYL TAPE, T224</p>	

Peel off approximately 1/4” of BUTYL TAPE and evenly wrap it around the bottom side of each 3/8-16UNC x 1.75 & 3/8-16UNC x 1.87” CARRIAGE BOLT head to seal holes in the OUTER RAIL.

Attach the HANDLE LATCH and the AXLE BRACKET to the OUTER RAIL using 1-3/4” & 1-7/8” CARRIAGE BOLT, 3/8” FLAT WASHER, 3/8” FLANGE NUT, tighten to recommended torque.

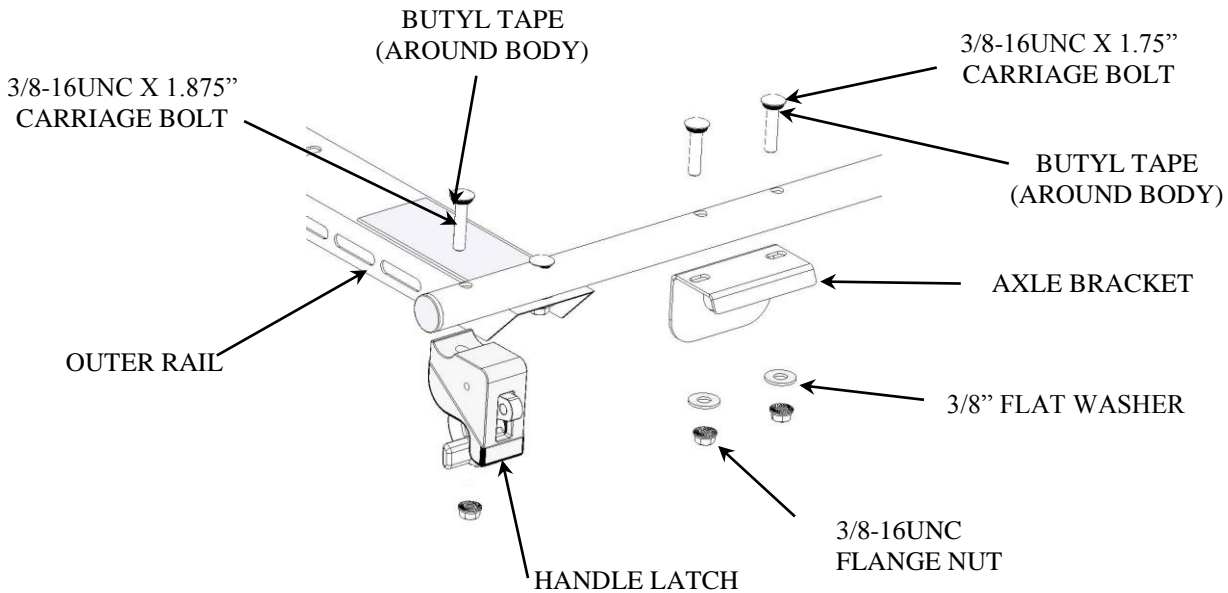







**STEP - 03**

**AXLE - SPRING PIN - BUSHING INSTALLATION**

The following fasteners and components are required to complete this step.

 <p><b>25337-0</b> 1/25" OD X 26.187" AXLE</p>	 <p><b>09677-0</b> 1.25" TUBE BUSHING (2) REQ'D</p>	 <p><b>FAS0212</b> 1/4"OD X 1.375" SPRING PIN (2) REQ'D</p>
---	--	--

Insert the AXLE through the hole in the AXLE BRACKET. **\*\*IMPORTANT** this end of the AXLE should have (3) holes in it: (see illustration below)

Next slide a BUSHING over the end of the AXLE and press the BUSHING flush into the hole in the AXLE BRACKET.

Now press the other BUSHING into the adjacent hole in the INNER RAIL and slide the other end of the AXLE through that BUSHING. (See illustration below)

Firmly tap a ROLL PIN into the smaller hole at the end of the AXLE that is in the AXLE BRACKET until the ROLL PIN stops inside the AXLE. **\*\*TIP:** partially slide the AXLE back out to allow enough clearance to safely swing hammer and prevent damage to parts.



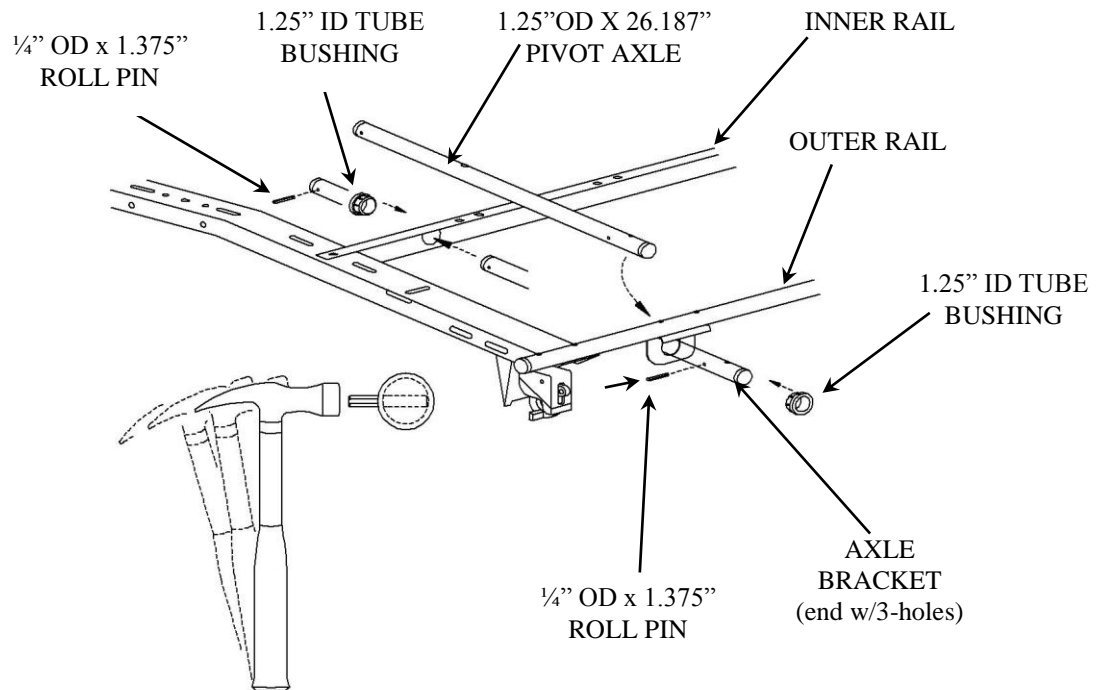



Now slide the AXLE all the way back in and tap the other ROLL PIN into the opposite end of the AXLE that goes through the INNER RAIL until the ROLL PIN stops inside the AXLE. **\*\*TIP:** rotate the axle around to provide better access to the roll pin hole.





## STEP – 04 ADJUSTABLE POST – CLAMP BRACKET INSTALLATION

The following fasteners and components are required to complete this step.

 <b>09704-0</b> 8" ADJUSTMENT POST	 <b>37515-0</b> CLAMP BRACKET	 <b>FAS0102</b> 3/8-16UNC X 1.00" CARRIAGE BOLT (1) REQ'D	 <b>FAS0184</b> 3/8-16UNC X 2.00" CARRIAGE BOLT (1) REQ'D	 <b>FAS0104</b> 3/8" FLAT WASHER (2) REQ'D	 <b>FAS0110</b> 3/8-16UNC NYLON LOCK NUT (2) REQ'D 31 ft-lbs ( +/- 2 ft-lbs )
---	--	--	--	--	---

Rotate the AXLE until the ROLL PIN points towards the HANDLE LATCH. (See illustration below)

Keeping the AXLE rotated this way, attach the ADJUSTMENT POST to the AXLE using a 3/8-16UNCx2.00" CARRIAGE BOLT, 3/8" FLAT WASHER, 3/8-16UNC NYLON LOCK NUT.

**\*\*NOTE:** once the 2" carriage bolt is inserted through the adjustment post and the axle seal the hole in the axle around the bolt with butyl tape before putting the 3/8" flat washer & 3/8-16UNC nylon lock nut on, tighten to recommended torque.

Next attach a CLAMP BRACKET to the ADJUSTMENT POST using a 3/8-16UNCx1.00" CARRIAGE BOLT, 3/8" FLAT WASHER, 3/8-16UNC NYLON LOCK NUT. (Do Not Tighten Yet!)

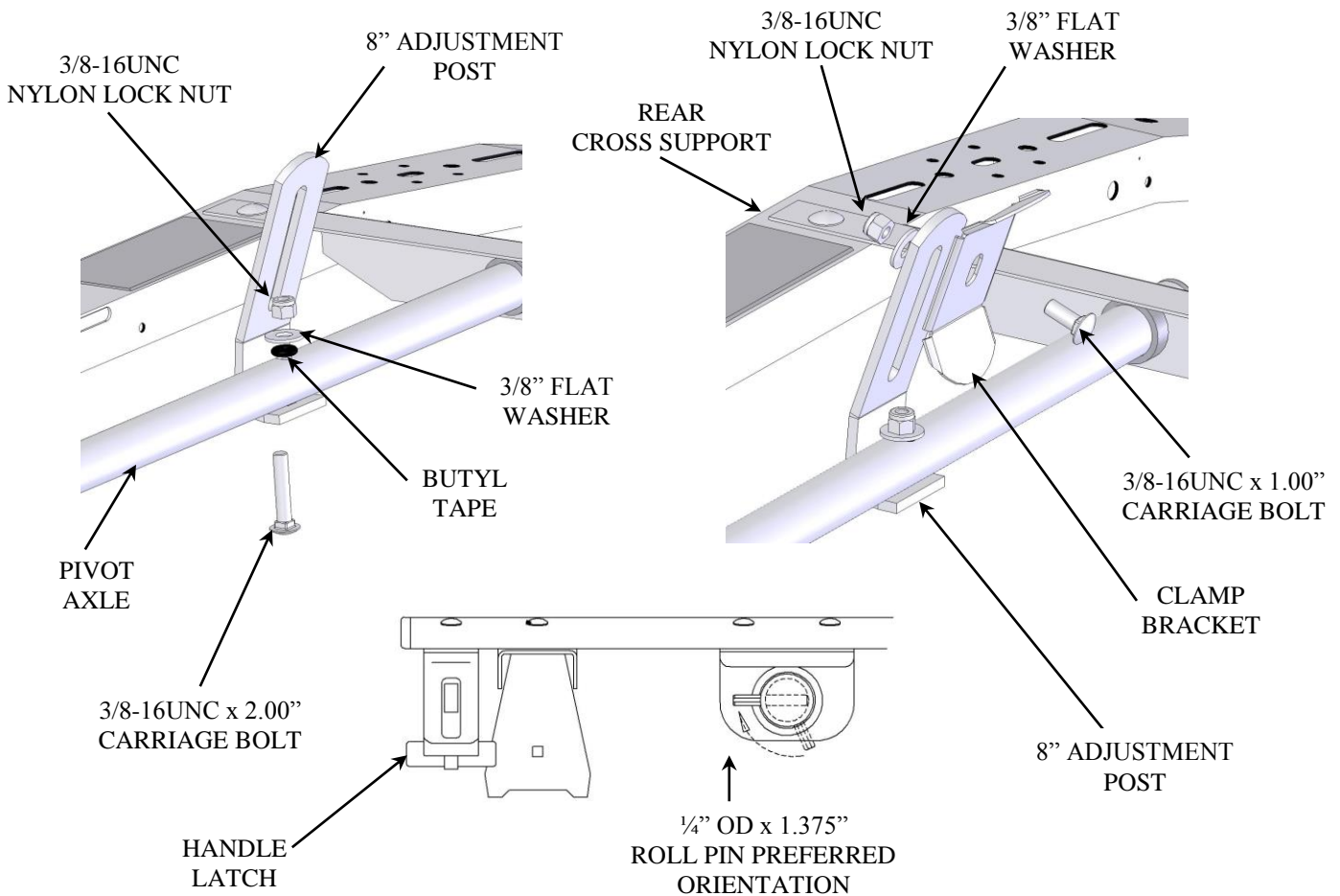



## STEP – 05 FRONT STOP POST – CLAMP BRACKET INSTALLATION

The following fasteners and components are required to complete this step.

 <b>25497-0</b> FRONT STOP POST	 <b>37515-0</b> CLAMP BRACKET	 <b>FAS0102</b> 3/8-16UNC X 1.00" CARRIAGE BOLT (2) REQ'D	 <b>FAS0104</b> 3/8" FLAT WASHER (2) REQ'D	 <b>FAS0110</b> 3/8-16UNC NYLON LOCK NUT (2) REQ'D 31 ft-lbs ( +/- 2 ft-lbs )
--	--	--	--	---

Insert the FRONT STOP POST into the front CROSS SUPPORT and attach with 3/8-16UNCx1.00" CARRIAGE BOLT, 3/8" FLAT WASHER, 3/8-16UNC NYLON LOCK NUT. (Do Not Tighten Yet!).

Attach a CLAMP BRACKET to the FRONT STOP POST using a 3/8-16UNCx1.00" CARRIAGE BOLT, 3/8" FLAT WASHER, 3/8-16UNC NYLON LOCK NUT. (Do Not Tighten Yet!)

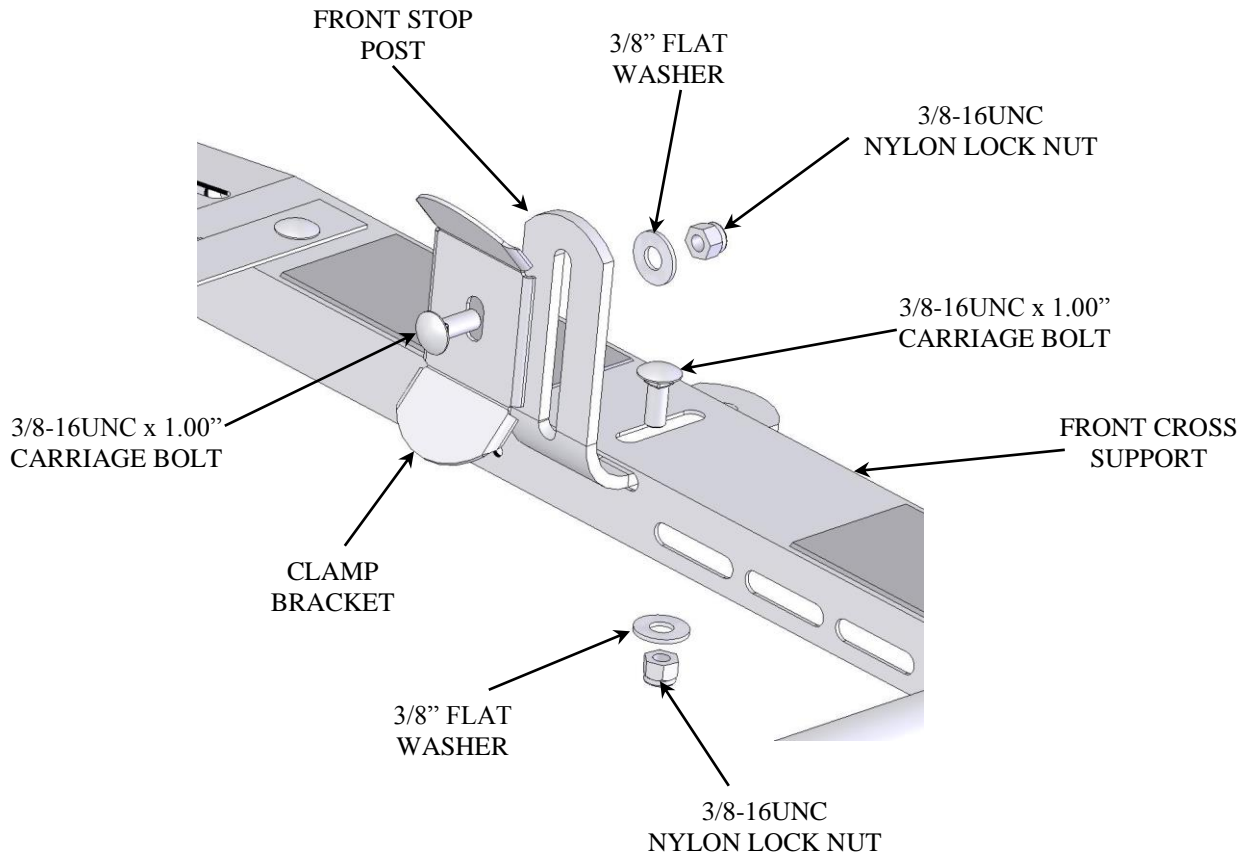



## STEP – 06

## HANDLE BAR INSTALLATION

The following fasteners and components are required to complete this step.

 <p><b>17976-0</b> 5/16-18UNC x 2.25" SHOULDER BOLT (1) REQ'D</p>	 <p><b>25410-0</b> HANDLE BAR (GRIPLOCK LDRK) (1) REQ'D</p>	 <p><b>FAS0124</b> 1/4" FLAT WASHER (2) REQ'D</p>	 <p><b>10103-0</b> .813 B-NYLON FLAT WASHER (1) REQ'D</p>	 <p><b>FAS0058</b> 1/4-20UNC, NYLON LOCK NUT (1) REQ'D 8 ft-lbs (+/- 2 ft-lbs)</p>
--	--	--	---	---

Insert the 2-1/4" SHOULDER BOLT through a 1/4" FLAT WASHER and then through the AXLE. NOTE: the head of the shoulder bolt should face up once the handle bar is attached.

Next insert a NYLON WASHER over the SHOULDER BOLT and then attach the HANDLE BAR to the AXLE followed with another 1/4" FLAT WASHER and a 1/4" NYLON LOCK NUT. (Tighten Snug Only)

NOTE: the nylon washer should be between the axle and the handle bar. Use 1/8" Allen Wrench to hold the shoulder bolt when tightening fasteners.

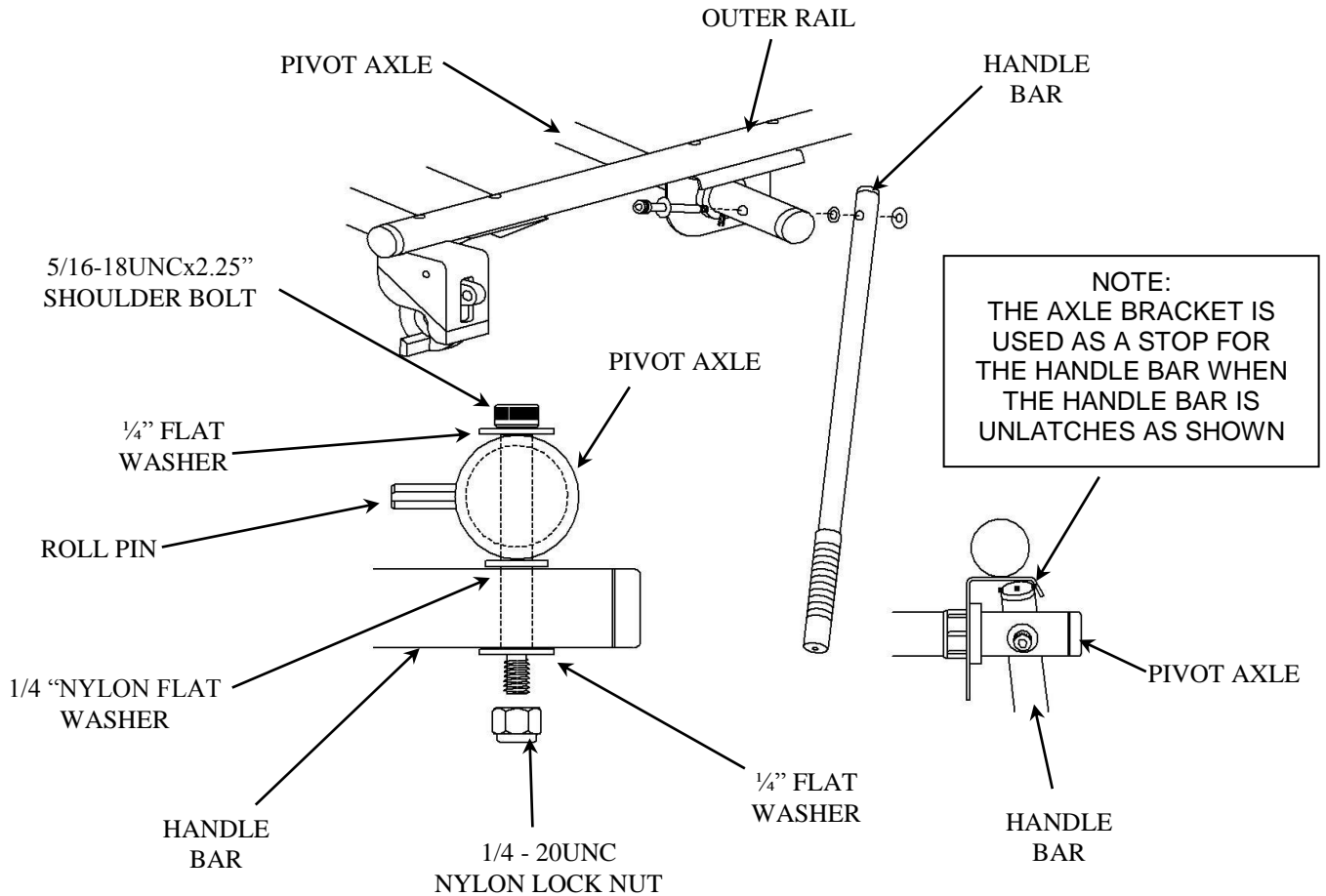





# “GRIP LOCK” Ladder Rack

## STEP – 07 FOOT CHANNEL TO CROSS SUPPORT ASSEMBLY

The following fasteners and components are required to complete this step.

 <p><b>16024-0</b> FOOT CHANNEL 4-3/8" (4) REQ'D</p>	 <p><b>FAS0102</b> 3/8-16UNC X 1.00" CARRIAGE BOLT (8) REQ'D</p>	 <p><b>FAS0104</b> 3/8" FLAT WASHER (8) REQ'D</p>	<p><b>FAS0100</b> 3/8-16UNC HEX FLANGE NUT (8) REQ'D 31 ft-lbs ( +/- 2 ft-lbs )</p>
---	---	---	---

Attach the FOOT CHANNELS using 3/8-16UNCx1.00" CARRIAGE BOLT, 3/8" FLAT WASHER, 3/8-16UNC HEX FLANGE NUT for each slot in the FOOT CHANNELS (Finger Tighten Only). The final adjustment should be made during installation, the foot channels should be even distances from each end of the cross support to center the ladder rack on top of the van.

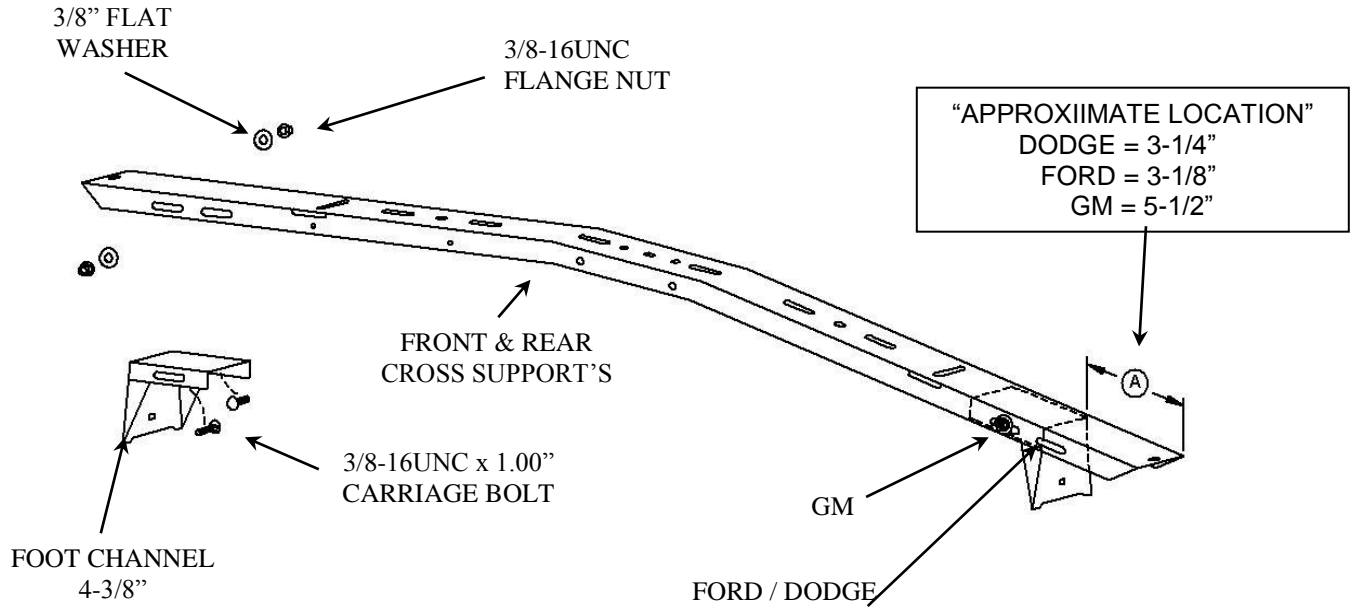



**STEP – 08**

## LADDER RACK INSTALLATION ON VEHICLE



**CAUTION!**  
AT LEAST TWO OR MORE PEOPLE ARE RECOMMENDED TO SET THE LADDER RACK ON TOP OF THE VEHICLE FOR SAFETY AND TO PROTECT VEHICLE ROOF



### PLACEMENT OF LADDER RACK ON FULL SIZE VANS (LONG WHEEL BASE VAN SHOWN)

The illustration below shows suggested ladder rack positions to help center your ladder on the ladder rack based on the size of ladder you intend to carry.

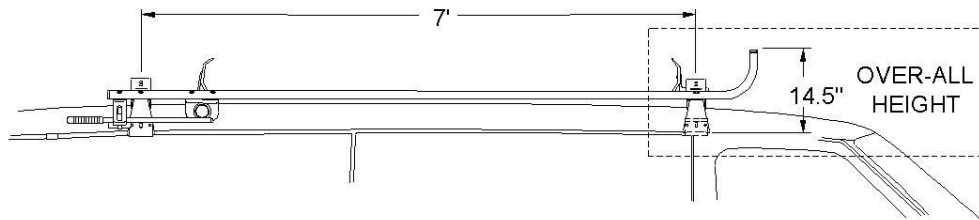
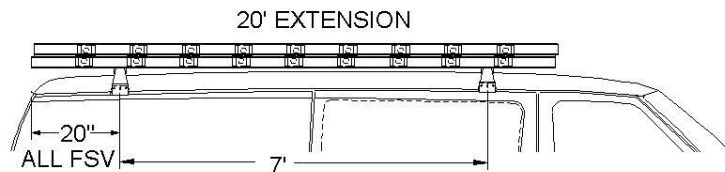
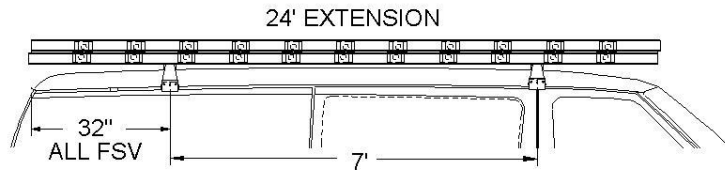
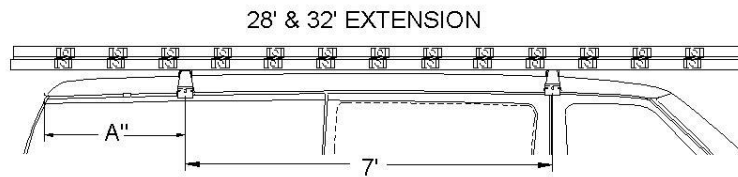

Caution! Never carry your ladder extended past the rear bumper.

- |                      |
|----------------------|
| <b>DIMENSION “A”</b> |
| FORD LWB = 32”       |
| FORD XLWB = 32”      |
| GM LWB = 30”         |
| GM XLWB = 30”        |
| DODGE SWB = 14”      |
| DODGE LWB = 20”      |
| DODGE XLWB = 32”     |



**“GRIP LOCK” Ladder Rack****STEP – 09 SECURING LADDER RACK TO VEHICLE ROOF DRIP EDGE**

The following fasteners and components are required to complete this step.

					
<b>11427-0</b> FOOT CLAMP, DRIP RAIL ( FORD / DODGE FSV )	<b>22856-0</b> FOOT CLAMP, GMT600 ( GM FSV )	<b>FAS0117</b> 3/8-16UNC x 1.50 CARRIAGE BOLT	<b>FAS0139</b> 1/2" FLAT WASHER	<b>07466-0</b> CAM NUT, ADJUSTABLE ( 4 ) REQ'D	<b>FAS0110</b> 3/8-16UNC NYLON LOCK NUT 31 ft-lbs ( +/- 2 ft-lbs )

Once you have the ladder rack positioned on top of the van, adjust all the FOOT CHANNELS to the drip rails while centering the ladder rack (side to side) on top of the van.

Insert a 3/8-16UNC x 1.50" CARRIAGE BOLT through the hole from behind the FOOT CHANNEL. Next slide a 1/2" FLAT WASHER over the 1.50" CARRIAGE BOLT.

Next attach a FOOT CLAMP, use 11427-0 for FORD/DODGE FSV or 22856-0 for GM FSV, be sure the bottom lip of the foot clamp grips under the drip rail.

Now slide a CAM Nut over the 1.50" CARRIAGE BOLT and snug it against the FOOT CLAMP with a 3/8-16UNC Nylon Lock NUT. Be sure the CAM NUT is flat against the FOOT CLAMP.

Loosen the 3/8"-16UNC Nylon Lock Nut 1/4 of a turn and use a 5/8" combination end wrench to rotate the CAM NUT clockwise to tighten the FOOT CLAMP against the drip rail. Now firmly tighten the 3/8"-16UNC Nylon Lock Nut to the recommended torque. Repeat the steps for the remaining FOOT CLAMPS.

Note: For DODGE short wheelbase vans with sliding side doors refer to STEP 10

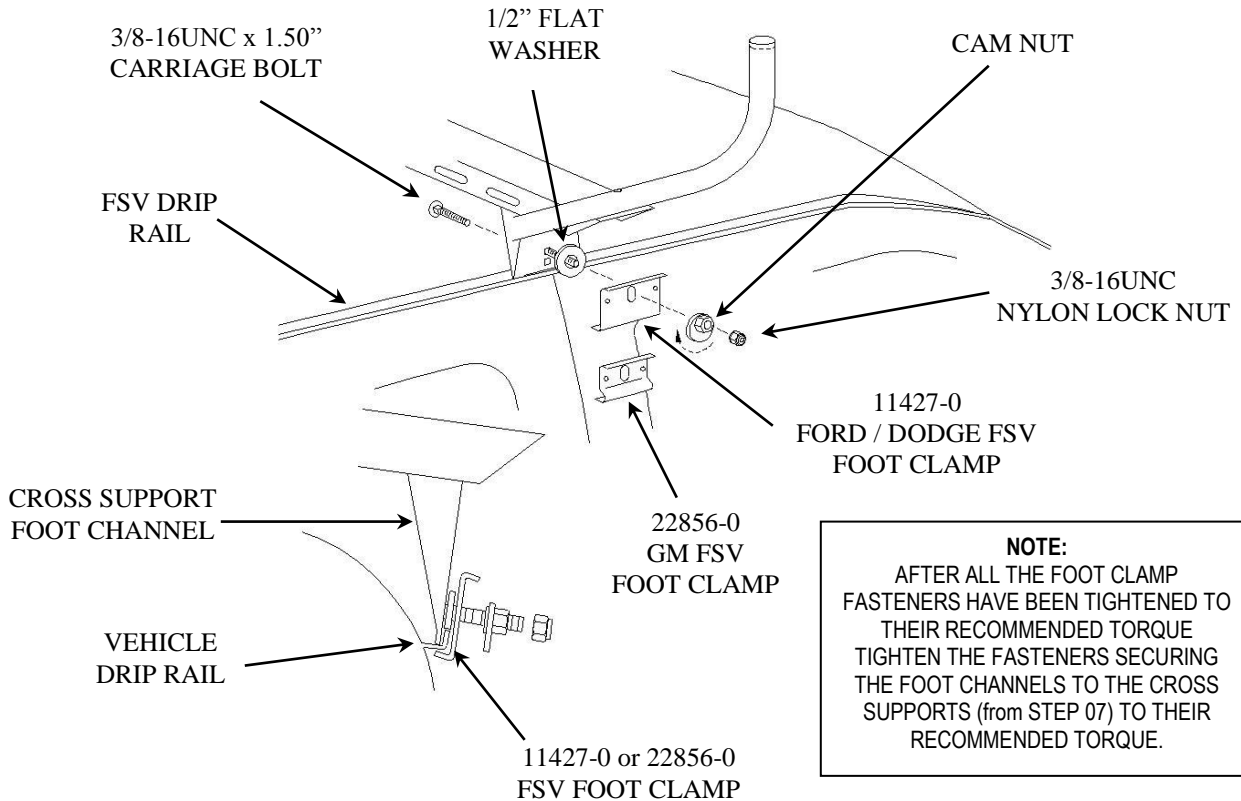

**NOTE:**  
AFTER ALL THE FOOT CLAMP FASTENERS HAVE BEEN TIGHTENED TO THEIR RECOMMENDED TORQUE TIGHTEN THE FASTENERS SECURING THE FOOT CHANNELS TO THE CROSS SUPPORTS (from STEP 07) TO THEIR RECOMMENDED TORQUE.



**STEP – 10 DODGE SHORT WHEELBASE VANS WITH SLIDING SIDE DOOR**

**“REAR FOOT CLAMP – PASSENGER (CURB) SIDE”**

Mark the door track cover where the FOOT CHANNEL contacts it, see illustration below. Drill (2) 3/8" diameter holes 4" apart through the door track cover on the area you just marked. Trim out the metal between the two holes you just drilled. Now you should have clearance to insert the FOOT CHANNEL through the door track cover, and attach it to the FOOT CHANNEL the same way as the other FOOT CLAMPS.

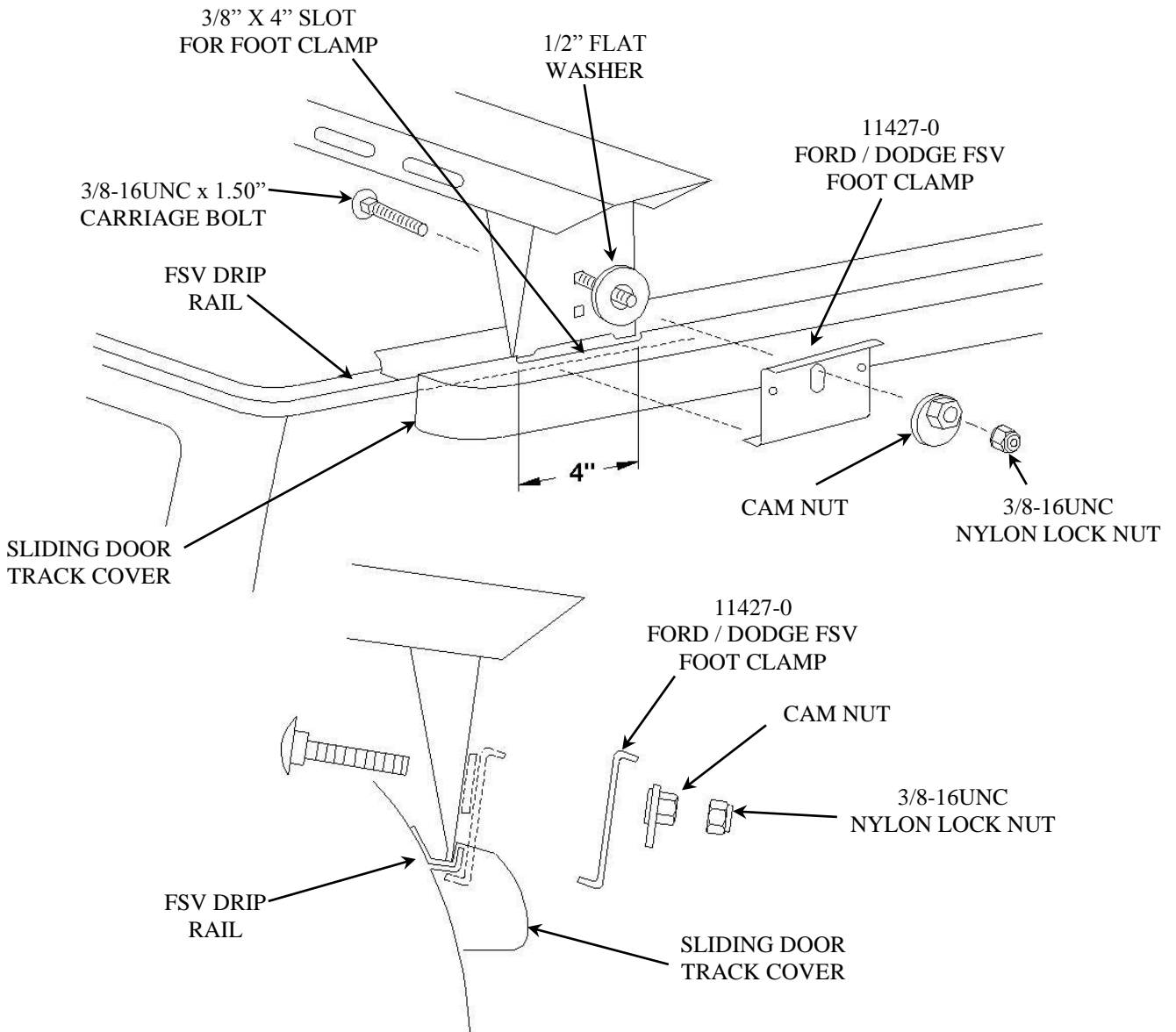





## Ladder Rack Adjustment

Load your ladder onto the ladder rack (see Loading & Unloading Section) and latch the HANDLE BAR into the HANDLE LATCH.

Now slide the ladder back towards the rear of the vehicle and slide the rear CLAMP BRACKET to fit snug over and against the ladder rungs as shown in illustration below.

Next slide the FRONT STOP POST at the front of the ladder rack back towards the rear of the vehicle and fit the front CLAMP BRACKET to the ladder rungs the same as the rear.

Tighten both front and rear CLAMP BRACKETS to their posts to their recommend torque. Snug the FRONT STOP POST to the front CROSS SUPPORT (fasteners hand tight only).

Now unlatch the HANDLE BAR and unload your ladder. Next loosen the FRONT STOP POST and slide it out towards the rear of the vehicle 1/2" and FIRMLY RETIGHTEN to their recommended torque.

### YOUR LADDER RACK SHOULD NOW BE ADJUSTED FOR YOUR LADDER

**\*\* CAUTION: Never carry your ladder feet extended past the rear bumper. \*\***

#### EXTENSION LADDER

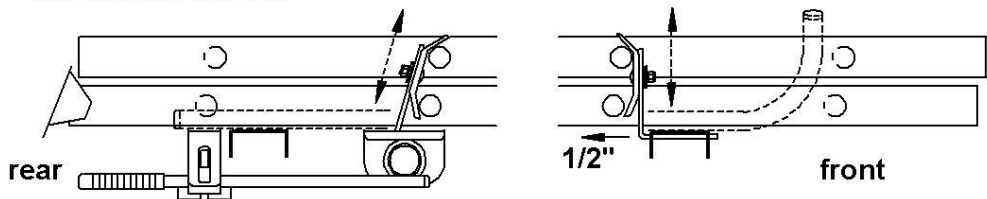

**\*\* CAUTION: Never clamp up the first step and the head of the STEP LADDER\*\***

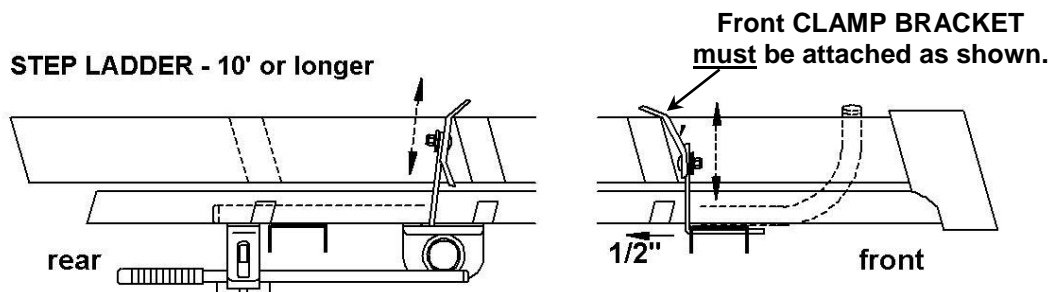

**NOTE: For step ladders under 10" order a "68-3 Step Ladder Kit".**



## LOADING AND UNLOADING

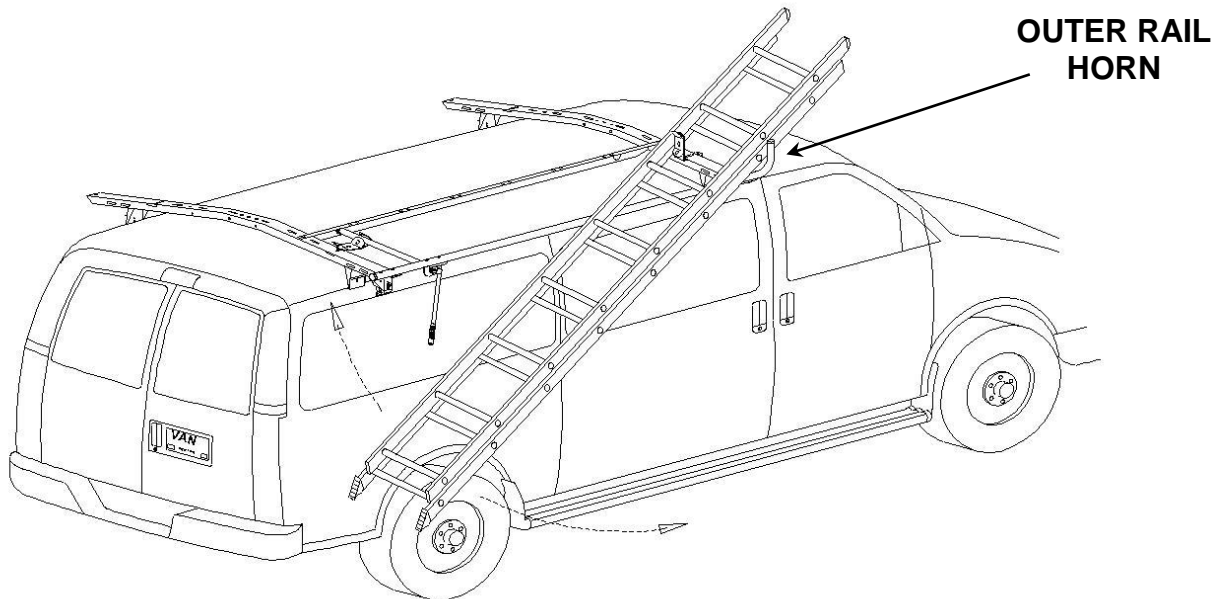

TO SAFELY LOAD & UNLOAD YOUR LADDER USE THE “OUTER RAIL HORN”  
AS A PIVOT POINT TO SUPPORT THE FRONT OF THE LADDER.  
THIS WILL MAKE LOADING AND UNLOADING YOUR LADDER A LOT EASIER AND SAFER!



**DOUBLE-CHECK ALL FASTENER LOCATIONS TO BE  
SURE THAT ALL FASTENERS ARE TIGHTENED TO  
SPECIFICATIONS!**



***YOUR INSTALLATION IS NOW COMPLETE! STOW THIS COPY IN THE VEHICLE  
FOR FUTURE REFERENCE!***

### **ATTENTION!! LADDER RACK PURCHASER**

It is advised that “all fasteners” that assemble and install your Ladder Rack is “checked for tightness” at (2) weeks of operation and then rechecked again at (6) weeks of operation.

Assembly fasteners could loosen due to vibration through your vehicle while on the road or in and out of construction sites.

“Drip Rail Clamps” could loosen due to the Ladder Rack Feet settling into the grouting that the O.E.M. put into the grip rail as a seal.

This is a preventative maintenance step to insure that your Ladder Rack give you a long service life.