

PRODUCT WEIGHT

**34 Lbs**

WIDTH x DEPTH x HEIGHT

**62" x 85" x 8"**

CAPACITY

**24' Extension Ladders  
Or 125 Lbs  
See Below**

COLOR

**Aluminum & Black**

CATALOG NUMBER

**61-NV2**

**PRODUCT FEATURES**

- LIGHTWEIGHT, SINGLE GRIP-LOCK LADDER RACK FOR THE NISSAN NV200 VAN.
- THIS RACK CAN CARRY FROM AN 8' STEP LADDER UP TO A 24' EXTENSION LADDERS. (**FOR 6' STEP LADDER SEE PAGE 2 FOR ADD ON SUPPORT KIT**).
- CAPACITY OF 1 LADDER.
- THIS RACK CAN ACCOMMODATE 28' EXTENSION LADDERS WHEN OVERHUNG OFF THE REAR OF THE VEHICLE TO BALANCE IT ON THE RACK. CHECK YOUR STATE AND LOCAL DOT REGULATIONS.
- ALUMINUM CONSTRUCTION WITH COMPOSITE SURFACES TO PREVENT DAMAGE TO LADDERS AND STAINLESS STEEL FASTENERS. NO DRILL INSTALLATION! ATTACHES TO FACTORY INSTALLED MOUNTING FASTENERS.

**SEE PAGE 2 FOR APPLICATION NOTES AND ACCESSORIES, OTHER PRODUCTS THAT WORK WITH THIS UNIT.**

**PAGE 1 of 2**



**CATALOG NUMBER      61-NV2**

***PRODUCT APPLICATION***

**THIS PRODUCT IS DESIGNED SPECIFICALLY FOR THE NISSAN  
NV200**

***ACCESSORIES THAT WILL WORK WITH THIS PRODUCT***

<b>CATALOG NUMBER</b>	<b>DESCRIPTION</b>
<b>1BNV200GL</b>	<b>CENTER BOW ADD-ON KIT FOR CARRYING 6' STEP LADDER</b>
<b>61TCSSUR</b>	<b>STREET SIDE UTILITY ADD-ON KIT TO CONVERT STREET SIDE TO A UTILITY RACK.</b>

***SPECIAL APPLICATION NOTES***

**Additional accessories may be compatible with this product.  
Please consult with ADRIAN STEEL ENGINEERING to review  
specific applications not listed here.**



### Introduction / Comments:

THIS LADDER RACK IS DESIGNED TO MOUNT TO THE FACTORY ATTACHMENT POINTS. REMOVE PLASTIC PLUGS TO INSTALL NEW RACK.

THIS RACK IS RATED TO CARRY 115 LBS EVENLY DISTRIBUTED ON THE RACK, OR A 24' EXTENTION LADDER. MAY CARRY A 28' EXTENSION LADDER WHEN OVERHUNG OFF THE REAR OF THE VEHICLE TO BALANCE IT ON THE RACK. CHECK YOUR STATE AND LOCAL DOT REGULATIONS. BE SURE ANY LOAD OR LADDER IS PROPERLY SECURED TO THE RACK PRIOR TO MOVING VEHICLE.  
INSTALLATION OF THIS RACK DOES **NOT** ACCOMMODATE USE OF SUNROOF!!!

**NOTE : THIS RACK UTILIZES SPECIFIC STREET AND CURB SIDE ROOF RAILS!!!**

**Note:**

It is advised that all fasteners used in this assembly and installation of this Rack should be checked for tightness at the following intervals: @ 2-weeks and again @ 6-weeks of operation. This preventive maintenance step must be completed to ensure your package gives you

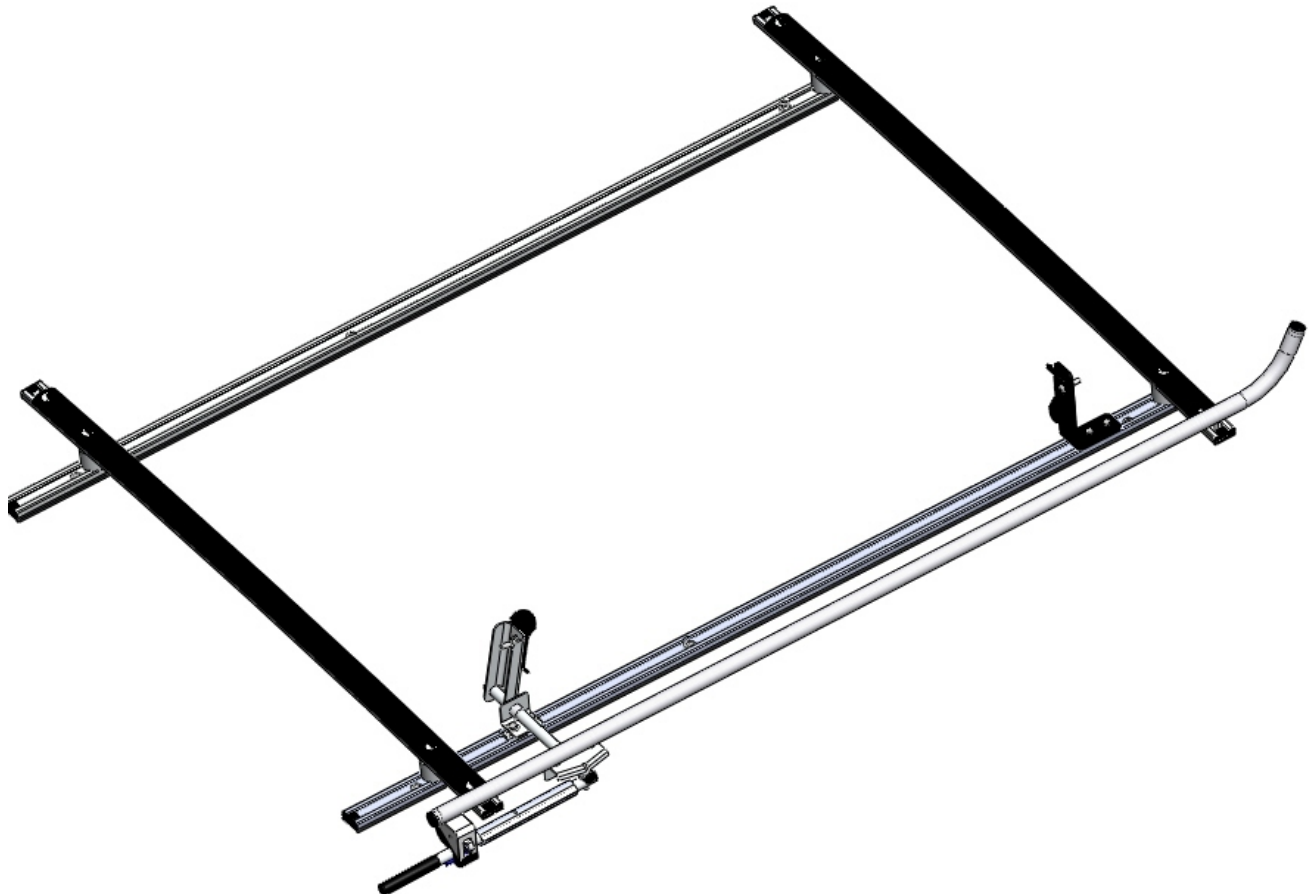

## 61-NV2 SINGLE GRIP-LOCK LADDER RACK ASM FOR NISSAN NV200 VAN



## - PRECAUTIONS -



**CAUTION**  
THE USE OF AIR IMPACT TOOLS CAN  
OVER-TORQUE FASTENERS AND  
CAUSE FASTENER FAILURE!



**CAUTION**  
ALL INSTALLATION HOLES SHOULD BE SEALED  
WITH SILICON OR BUTYL SEALANT TO PREVENT  
EXHAUST FUMES FROM ENTERING THE VEHICLE!



**DANGER**  
INSPECT FOR FUEL TANK, FUEL LINES, BRAKE LINES, HIGH  
VOLTAGE BATTERIES AND ELECTRICAL LINES PRIOR TO  
DRILLING TO AVOID DAMAGING CRITICAL VEHICLE SYSTEMS  
OR INJURY TO INSTALLER DURING INSTALLATION PROCESS!



**CAUTION**  
TO AVOID DAMAGING THE VEHICLE ALWAYS  
USE DRILL STOPS WHEN DRILLING ANY IN-  
STALLATION HOLES!



## - IMPORTANT WARRANTY REQUIREMENTS -

1. SUBSTITUTING ADRIAN STEEL SPECIFIED FASTENERS FOR ASSEMBLY AND/OR INSTALLATION WILL VOID YOUR PRODUCT WARRANTY.
2. ALL HOLES DRILLED INTO VEHICLE SHOULD HAVE THE RAW METAL EDGES SEALED WITH A SELF-ETCHING PRIMER TO RESIST CORROSION AND POTENTIAL FASTENER POINT FAILURE.
3. ALL FASTENERS USED IN THE INSTALLATION OF THIS PRODUCT SHOULD BE TIGHTENED TO THE TORQUE(S) SPECIFIED IN THESE INSTRUCTIONS.
4. THESE INSTRUCTIONS SHOULD BE KEPT WITH THE VEHICLE.

### THE BASIC TOOLS NEEDED FOR MOST INSTALLATIONS



DRILL



DRILL BIT WITH  
STOP



RATCHET, SOCKETS  
AND/OR WRENCHES



SCREWDRIVERS



MEASURING TAPE

ADDITIONAL TOOLS MAY BE NEEDED FOR THIS INSTALLATION AND THEY WILL BE IDENTIFIED IN THE STEPS THAT FOLLOW.



**BAG61-NV2  
FASTENER BAG FOR 61-NV2 LADDER RACK**

ITEM NO.	PART NUMBER	DESCRIPTION	QTY.
1	35335-0	SLIDE	8
2	36496-0	END CAP	8
3	FAS0698	PIN, SPRING .312X1.50 SS	1
4	FAS0577	Screw, Button Hd Hex Soc, 3/8-16x1.50 NI-ZN	2
5	FAS0830	Screw, Hex Hd, 5/16-18 X 1.25 SS	3
6	FAS 0720	Washer, Flat 3/8 SS	2
7	FAS0110	Nut, Hex Nylk 3/8-16 SS W	2
8	FAS0717	Screw, Hex Hd, 5/16-18x.625 SST	4
9	FAS0740	Shoulder Bolt,	1
10	FAS0234	Washer, Flat, 1/4, SST	1
11	FAS0125	Nut, Nylon Insert Lock, 1/4-20 SST	1
12	FAS0588	Washer, Lock, Split, 5/16, SS	19
13	BAG0709-A	7" x 9" 3MIL AUTOBAG	1
14	FAS0727	Screw, Button Hd Hex Soc, M8-1.25 X 30	6
15	FAS0242	Screw, Hex Hd, 5/16-18x1.50 Stainless Steel	2
16	FAS0552	Washer, Flat, 5/16, SST	19
17	FAS0243	Screw, Hex Hd, 5/16-18x2.50 Stainless Steel	4

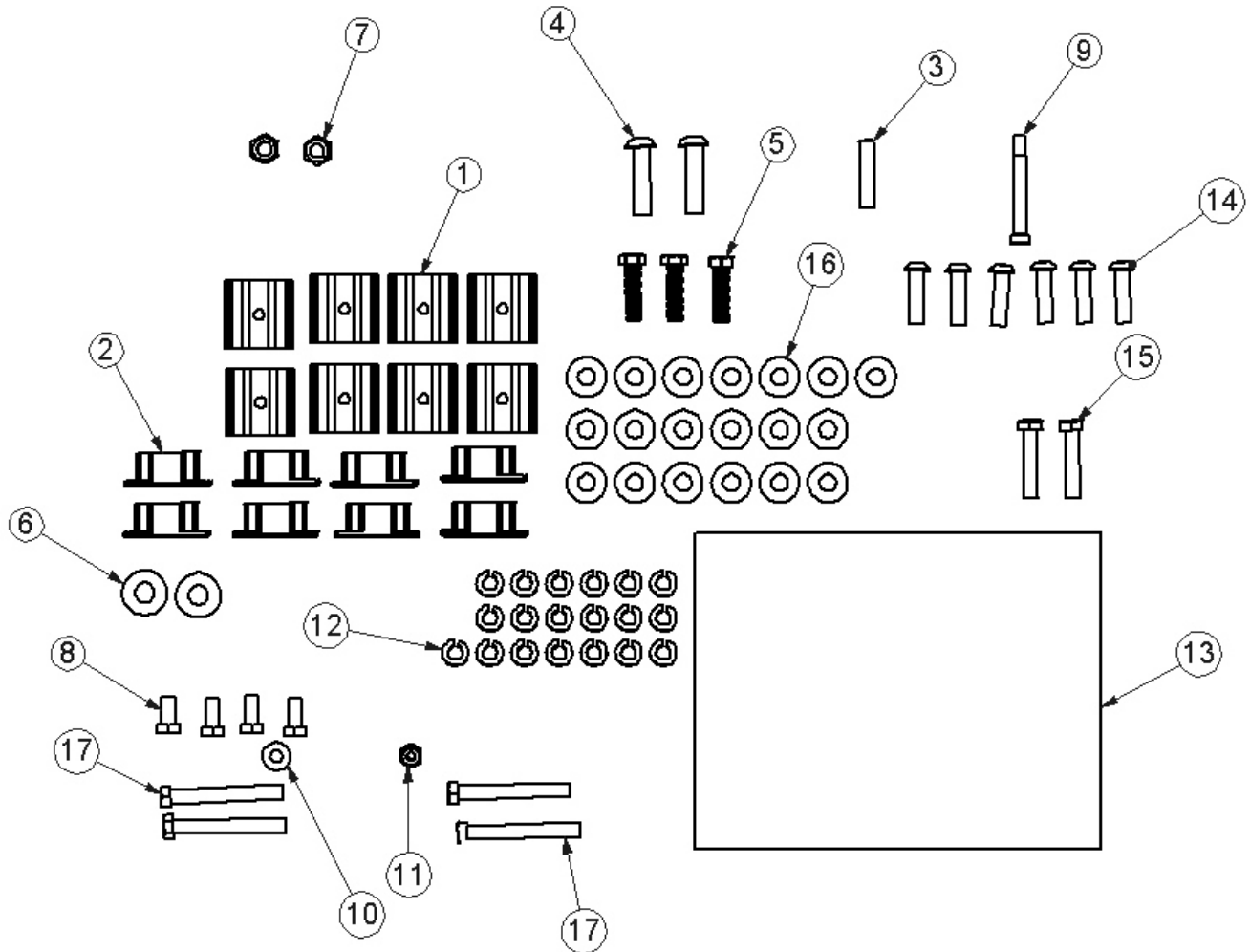



BAG37291 ACCESSORY BAG FOR 61-NV2

ITEM NO.	PART NUMBER	DESCRIPTION	BAG37291/QTY.
1	38846-B	BUSHING, G/L, TC	2
2	37517-0	End Cap, Black	2
3	05586-0	Butyl Tape, T224- 1/2"X 1' Roll	1
4	37272-0	Tape, 2 Side Adhesive	1
5	26618-0	Silicone Sealant	1
6	51363	CAP PLUG, RND, BLK, 1 DIA	2

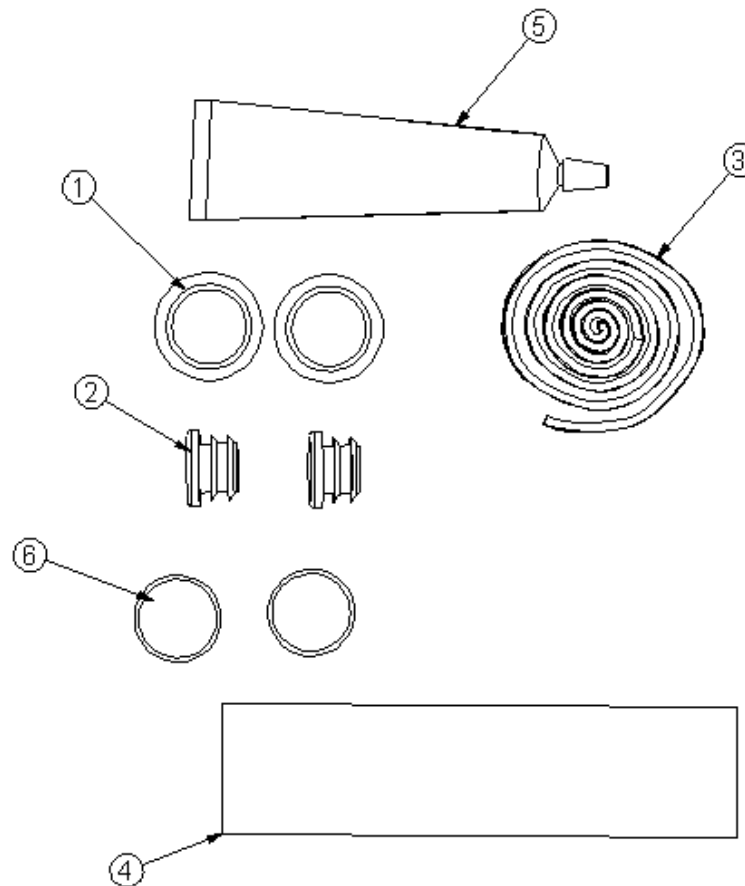



**STEP #01: ASSEMBLE ROOF RAILS. NOTE DIFFERENCES BETWEEN STREET AND CURB SIDE ROOF RAILS!!**

INSERT (6) 35335-0 SLIDES INTO CURB SIDE ROOF RAIL, 2 SLIDES INTO STREET SIDE ROOF RAIL, AND (1) 36496-0 END CAP INTO EACH END (4 TOTAL). PEEL AND STICK FOAM STRIP TO BOTTOM OF EACH RAIL.

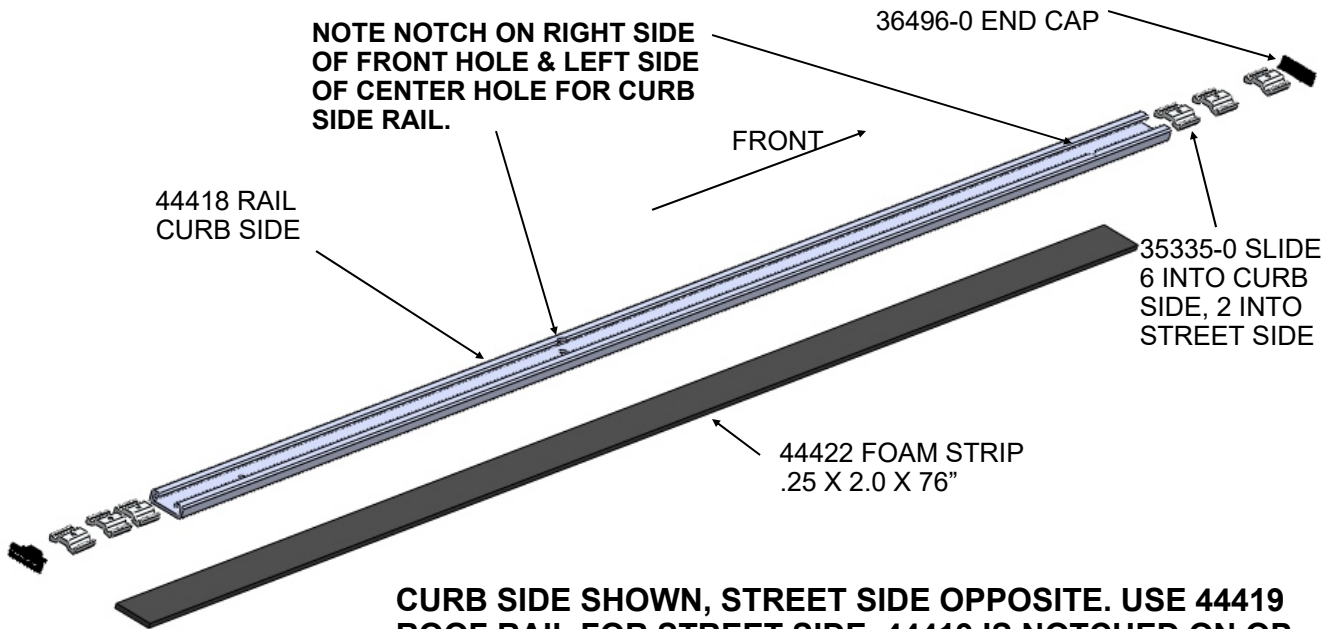

**CURB SIDE SHOWN, STREET SIDE OPPOSITE. USE 44419 ROOF RAIL FOR STREET SIDE. 44419 IS NOTCHED ON OPPOSITE SIDES OF FRONT & CENTER HOLES.**

**STEP #02 : ASSEMBLE 2 CROSS BOW ASMs.**

SLIDE WEAR INSERT INTO CROSS BOW UNTIL INNER HOLES LINE UP ON EACH END. INSERT (1) 36496-0 END CAP INTO EACH END OF EACH BOW ASM.

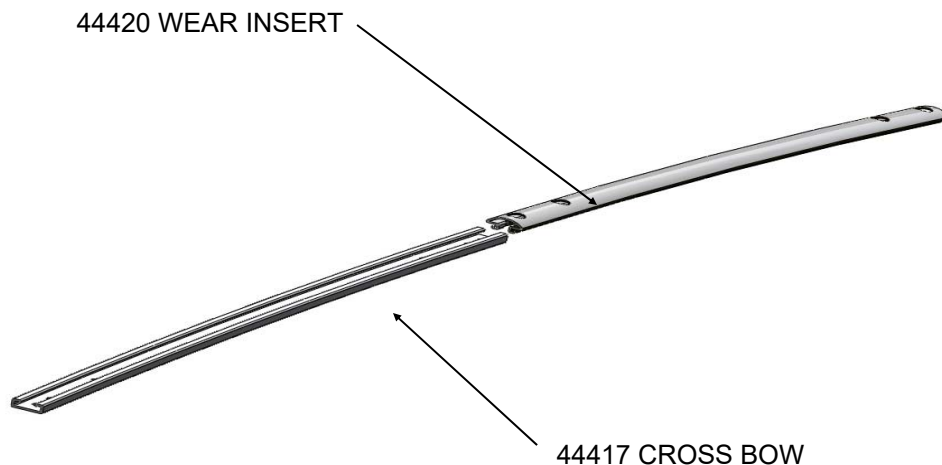



**STEP #03 : ASSEMBLE LADDER STOP TO ROOF RAIL, CURB SIDE ONLY**

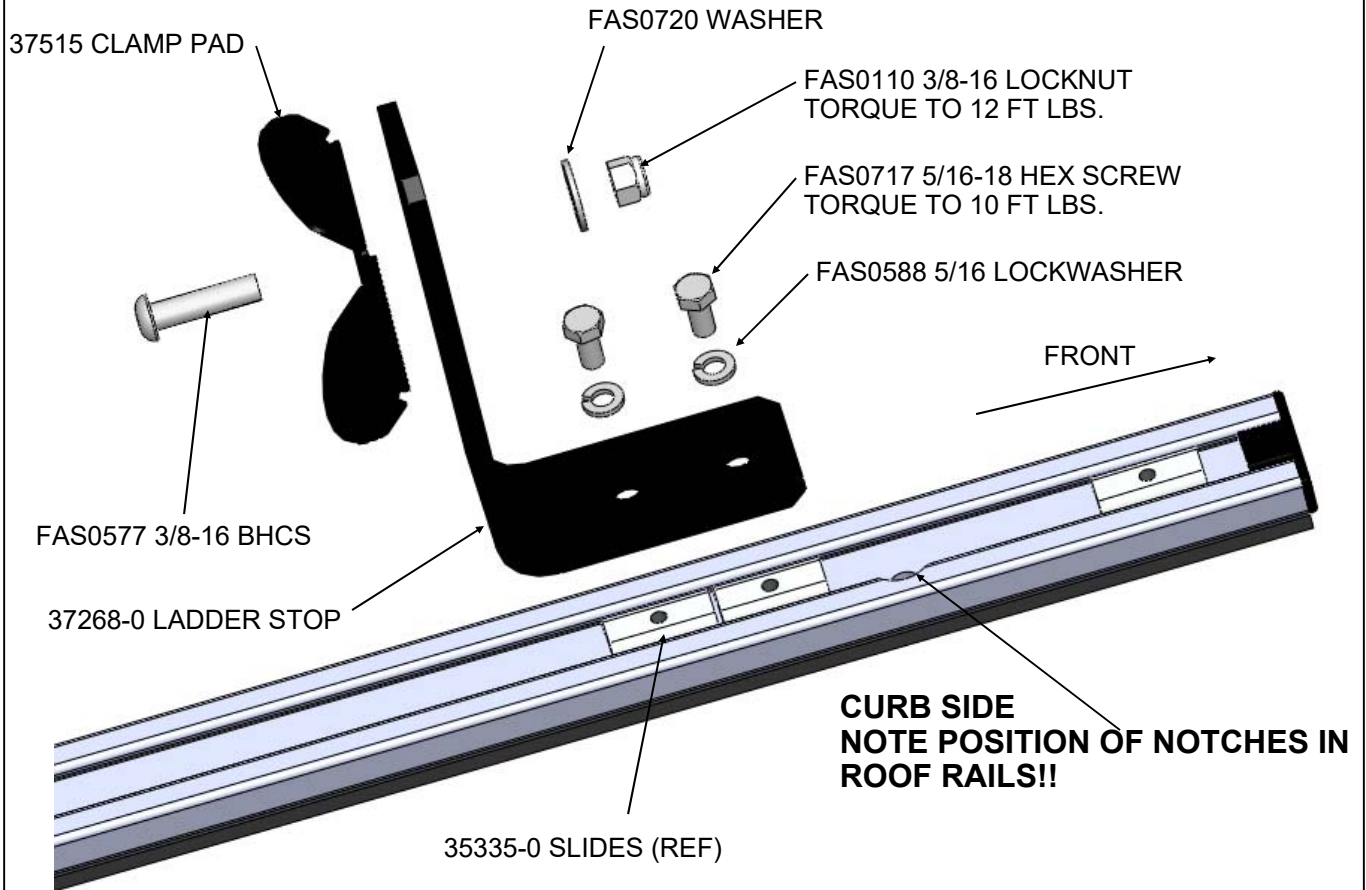

**STEP #04 : ASSEMBLE BOW ASMS TO ROOF RAILS**

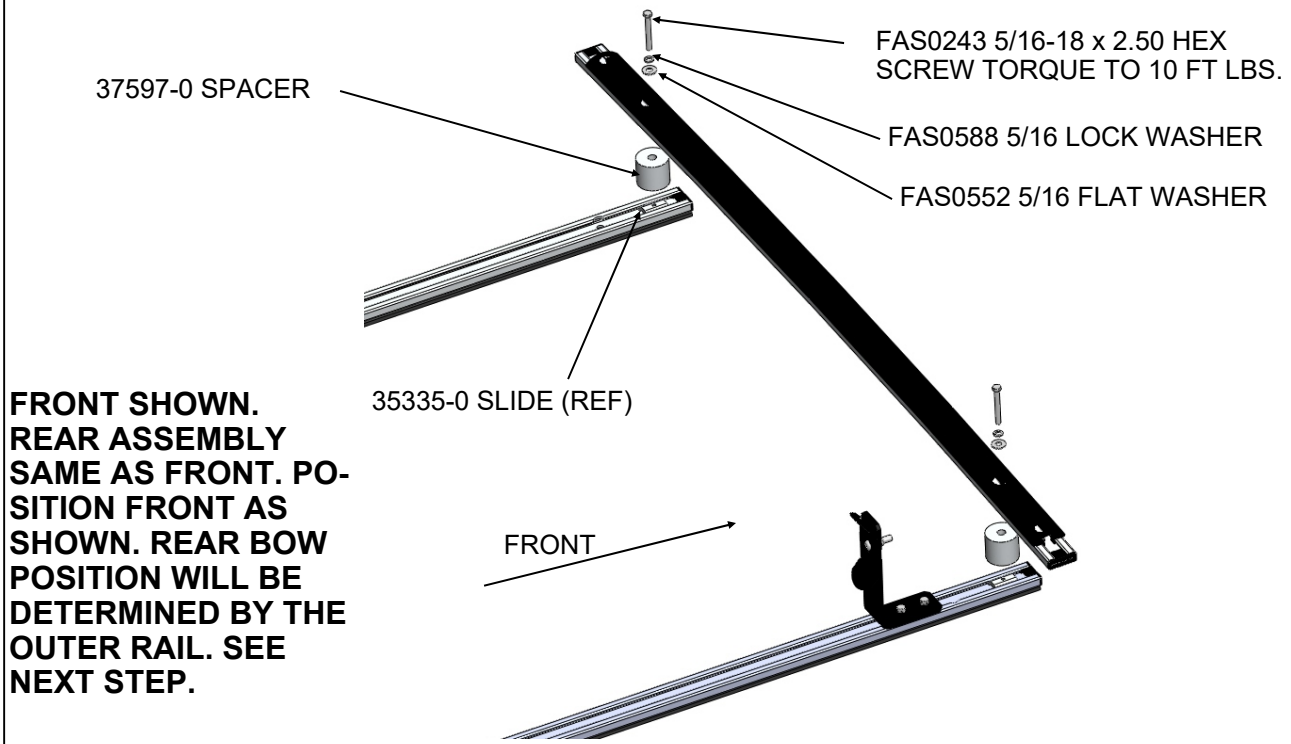





**STEP #05 ASSEMBLE OUTER RAILS TO RACK**

INSTALL (2) 51363 END CAPS INTO TUBE ENDS, INSTALL LATCH ASM AS SHOWN AND INSTALL ASM ON RACK.

**NOTE : OUTER RAIL HAS 5/16 RIVMUTS IN BOTTOM SIDE FOR ATTACHMENT.**

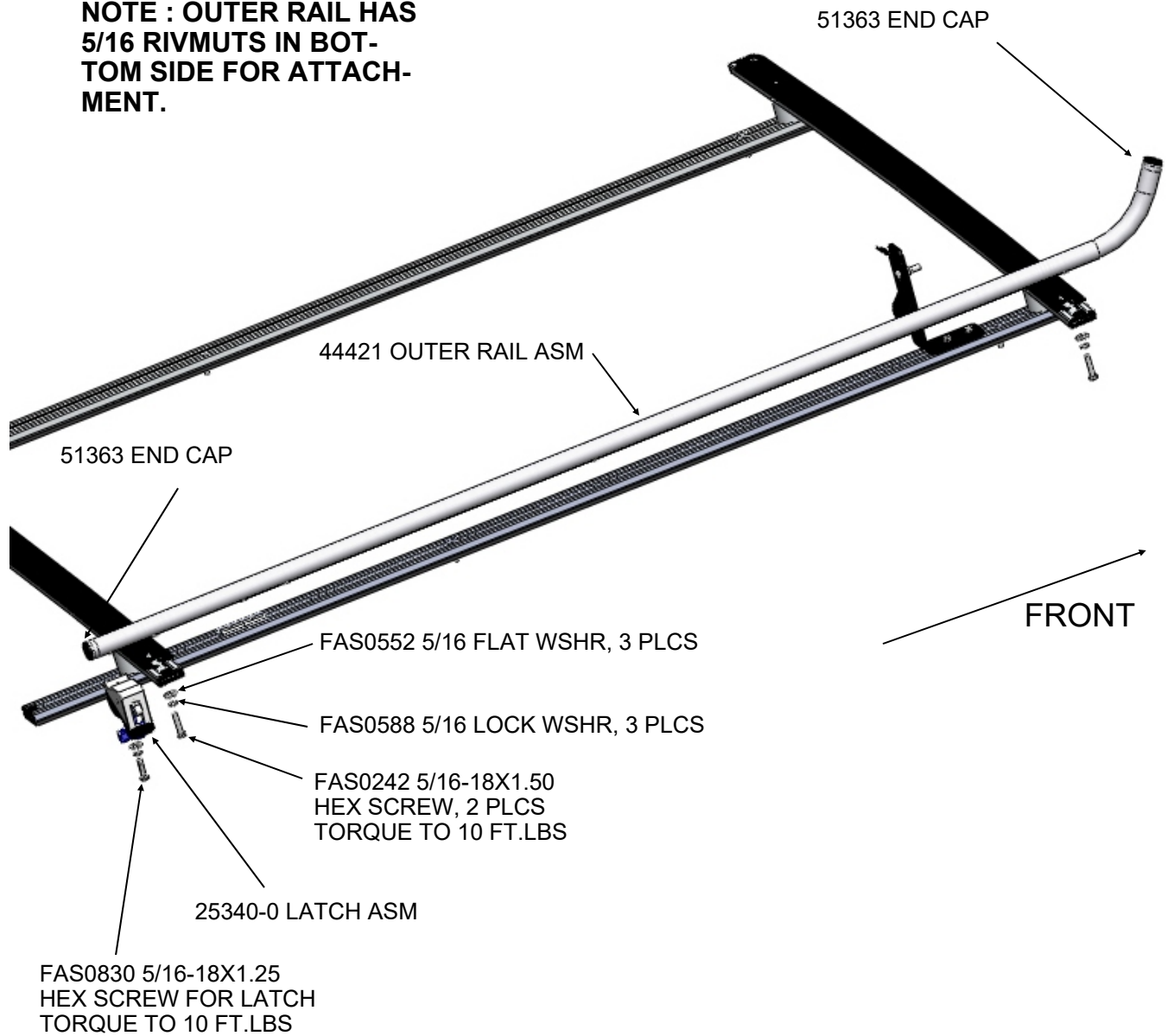



**STEP #06 ASSEMBLE GRIP-LOCK MECHANISM AND INSTALL ON RACK**

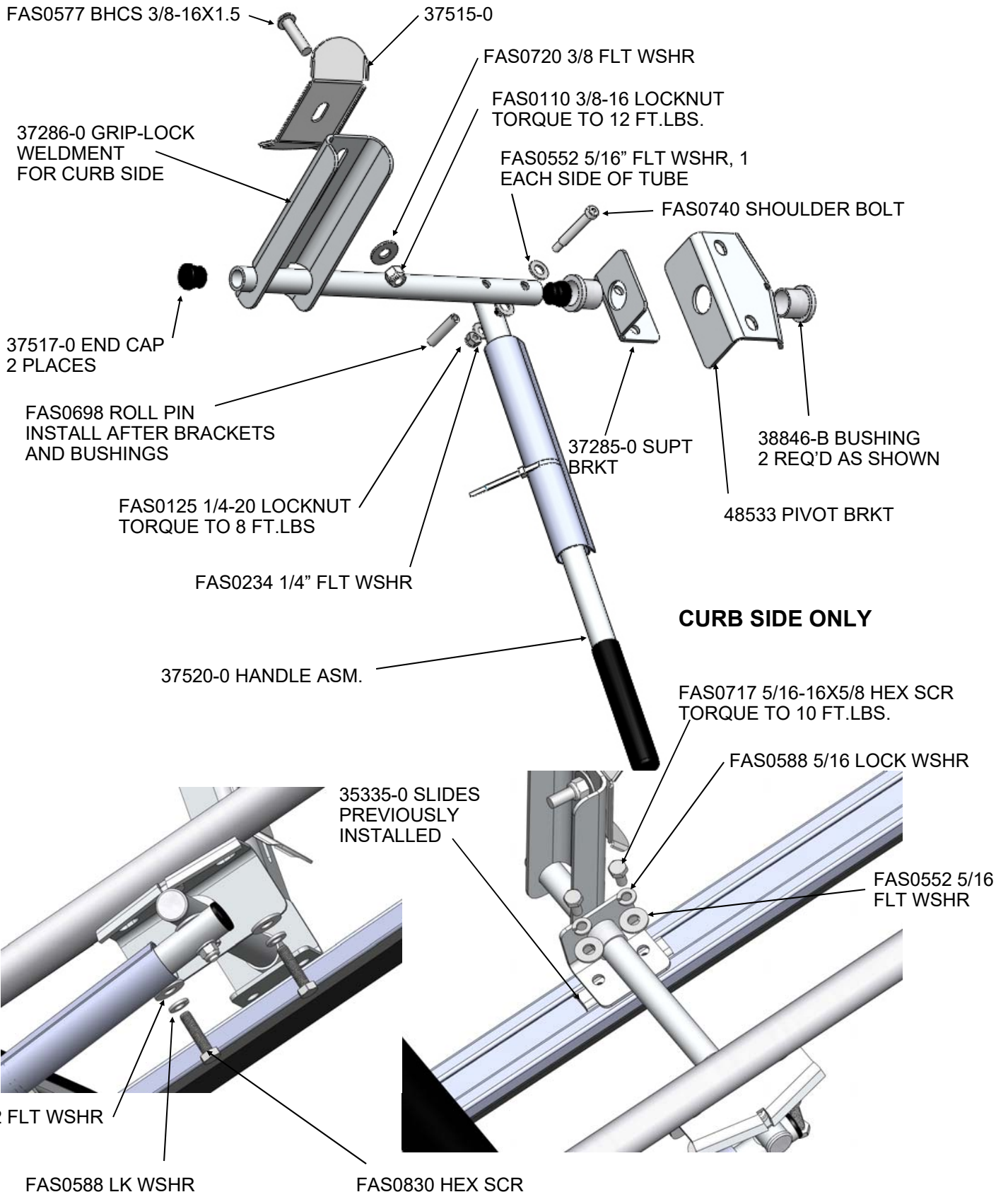



### STEP #07 ASSEMBLE GRIP-LOCK RACK TO VEHICLE

REMOVE OEM PLASTIC PLUGS (6) FROM ROOF. THESE ARE THE ATTACHMENT POINTS FOR THE RACK. POSITION THE RACK ON ROOF AND SCREW THE FAS0727 SCREWS INTO THE OEM WELD-NUTS IN ROOF STRUCTURE AFTER APPLYING SOME SILICONE SEALANT TO THE THREADS. TORQUE AS SHOWN USING 5MM ALLEN WRENCH. FASTENERS SHOWN BELOW ARE TYPICAL AT ALL 6 ATTACHMENT POINTS.

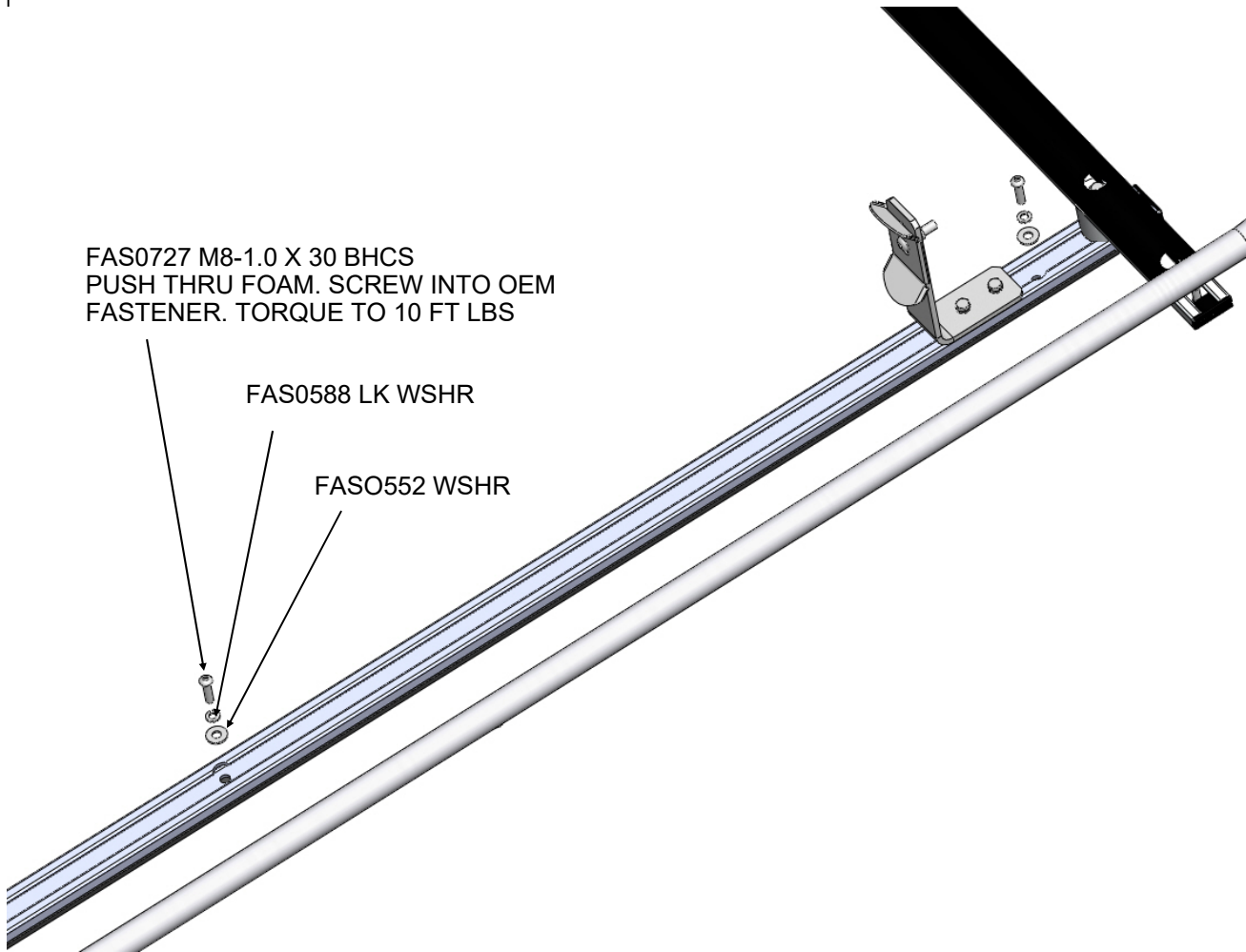

FAS0727 M8-1.0 X 30 BHCS  
PUSH THRU FOAM. SCREW INTO OEM  
FASTENER. TORQUE TO 10 FT LBS

FAS0588 LK WSHR

FASO552 WSHR



***DOUBLE-CHECK ALL FASTENER LOCATIONS TO  
BE SURE THAT ALL FASTENERS ARE TIGHTENED  
TO SPECIFICATIONS!***

