

PRODUCT WEIGHT
42 lbs

WIDTH x DEPTH x HEIGHT

CAPACITY
28 FOOT EXT

COLOR
Aluminum / Black

CATALOG NUMBER
61-GLNVL2

PRODUCT FEATURES

This Grip Lock and Roof Cross-bow Kit is designed to fit the Nissan NV, low roof vehicle. The grip lock will carry 16 to 28 foot extension ladders, and 8 to 12 foot step ladders. For shorter ladders, you will need the grip lock step ladder kit, GLSLKFSV. Use 69-GL for a 32 foot extension ladder.

The Cross-bow kit is secured to the Nissan by OEM supplied fastening point.

SEE PAGE 2 FOR APPLICATION NOTES AND ACCESSORIES, OTHER PRODUCTS THAT WORK WITH THIS UNIT.

CATALOG NUMBER 61-GLNVL2***PRODUCT APPLICATION***

This Single grip lock kit is designed to fit the Nissan NV, low roof vehicles.

ACCESSORIES THAT WILL WORK WITH THIS PRODUCT

CATALOG NUMBER	DESCRIPTION
GLSLKFSV	STEP LADDER KIT , GRIP LOCK
54628	GRIP LOCK,STREET SIDE (CONVERTS TO DBL GRIP LOCK)
69-GL	EXTENSION, GRIP LOCK LADDER RACK—FOR 32 FOOT LADDER
80-1LR 80-2LR	CONDUIT KITS, ALUMINUM
70-1LR 70-2LR	CONDUIT KITS, PVC

SPECIAL APPLICATION NOTES

Introduction / Comments:

THIS ROOF RAIL AND CROSS BOW KIT IS DESIGNED FOR THE NISSAN LOW ROOF VAN. IT IS THE BASE UNIT FOR ALL OF THE LADDER RACK COMBINATIONS FOR THIS VEHICLE.

Note:

It is advised that all fasteners used in this assembly and installation of this Rack should be checked for tightness at the following intervals: @ 2-weeks and again @ 6-weeks of operation. This preventive maintenance step must be completed to ensure your package gives you long service life.



TO VIEW INSTALL VIDEO

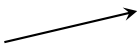

**RRKNV
ROOF RAIL AND CROSS BOW KIT
NISSAN LOW ROOF VAN**

- PRECAUTIONS -



CAUTION
THE USE OF AIR IMPACT TOOLS CAN OVER-TORQUE FASTENERS AND CAUSE FASTENER FAILURE!



CAUTION
ALL INSTALLATION HOLES SHOULD BE SEALED WITH SILICON OR BUTYL SEALANT TO PREVENT EXHAUST FUMES FROM ENTERING THE VEHICLE!



DANGER
INSPECT FOR FUEL TANK, FUEL LINES, BRAKE LINES, HIGH VOLTAGE BATTERIES AND ELECTRICAL LINES PRIOR TO DRILLING TO AVOID DAMAGING CRITICAL VEHICLE SYSTEMS OR INJURY TO INSTALLER DURING INSTALLATION PROCESS!



CAUTION
TO AVOID DAMAGING THE VEHICLE ALWAYS USE DRILL STOPS WHEN DRILLING ANY INSTALLATION HOLES!
ADRIAN AVAILABLE PART #'S 31121-0 (3/8" X 1/2" DEEP), 31121-0 (1/2" x 1/2" DEEP)



- IMPORTANT WARRANTY REQUIREMENTS -

1. SUBSTITUTING ADRIAN STEEL SPECIFIED FASTENERS FOR ASSEMBLY AND/OR INSTALLATION WILL VOID YOUR PRODUCT WARRANTY.
2. ALL HOLES DRILLED INTO VEHICLE SHOULD HAVE THE RAW METAL EDGES SEALED WITH A SELF-ETCHING PRIMER TO RESIST CORROSION AND POTENTIAL FASTENER POINT FAILURE.
3. ALL FASTENERS USED IN THE INSTALLATION OF THIS PRODUCT SHOULD BE TIGHTENED TO THE TORQUE(S) SPECIFIED IN THESE INSTRUCTIONS.
4. THESE INSTRUCTIONS SHOULD BE KEPT WITH THE VEHICLE.

THE BASIC TOOLS NEEDED FOR MOST INSTALLATIONS



DRILL



DRILL BIT WITH STOP



RATCHET, SOCKETS AND/OR WRENCHES



SCREWDRIVERS



MEASURING TAPE

ADDITIONAL TOOLS MAY BE NEEDED FOR THIS INSTALLATION AND THEY WILL BE IDENTIFIED IN THE STEPS THAT FOLLOW.

If your vehicle contains carpet or a rubber floor mat you will need to prepare the mounting location. Position the product to be installed into the vehicle and once you are satisfied with the mounting locations, mark the mounting locations. Using a 1-3/16" diameter carpet cutter (P/N: 31183-0). Select the appropriate floor spacers as shown in the illustration. Set those aside for use later into the installation process. Using the correct drill bit size for the selected plusnut, drill the mounting holes in the vehicle sheet metal to prepare for installing the plusnuts. If you are thru-bolting at any of the locations simply drill a hole that is 1/16" larger than the bolt size(s) for those locations. Once you have drilled the holes into the vehicle, the raw metal edges should be sealed using a self-etching primer to resist corrosion and potential fastener point failure.

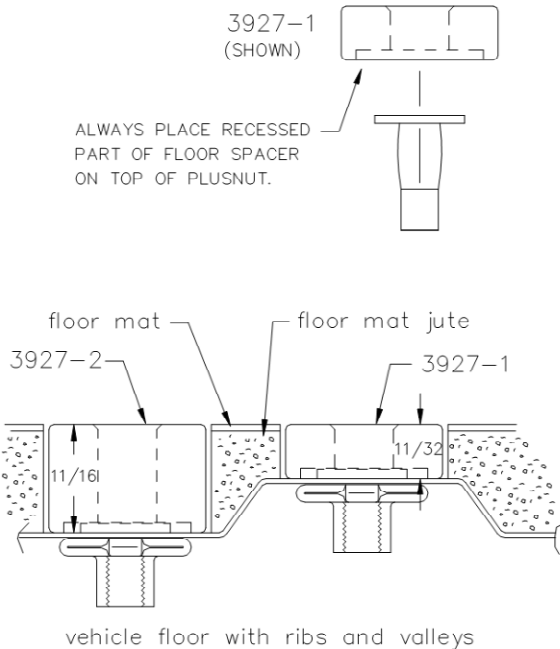

A PLUSNUT (RIVNUT) SETTING TOOL IS REQUIRED FOR PLUSNUT (RIVNUT) INSTALLATION . PLUS NUT SETTING TOOL CAN BE ORDERED THROUGH ADRIAN STEEL, OR USE AN AIR POWERED PLUSNUT SETTING GUN.

1/4-20UNC Plusnut (FAS0052) Use 3/8" dia. drill w/stop
 FAS0080 SCREW, HXHD, 1/4-20UNCx2.00", G8
 FAS0067 WASHER, FLAT, 1/4"ID
 22200-0 PLUSNUT TOOL

5/16-18UNC Plusnut (FAS0091) Use 1/2" dia. drill w/stop
 FAS0095 SCREW, HXHD, 5/16-18UNCx2.00", G8
 FAS0086 WASHER, FLAT, 5/16"ID
 22200-0 PLUSNUT TOOL

Place barrel of the plusnut body in sheet metal thru hole until flange is flush with sheet metal. Using a 9/16" combination wrench of plusnut tool body and a second hand wrench, ratchet, or air tool, rotate the hex bolt head CW to draw plus nut flanges up (set the plusnut).

BAG52539 - FASTENER BAG, ROOF RAIL KIT

ITEM NO.	PART NUMBER	DESCRIPTION	QTY.
1	BAG0406-A	4" x 6" 3MIL AUTOBAG	1
2	FAS0552	Washer, Flat, 5/16, SST	16
3	FAS0759	5/16-18 U-NUT	16
4	FAS0283	Screw, Hex Hd, 5/16-18 x.875 SST	16
5	FAS0588	Washer, Lock, Split, 5/16, SS	16

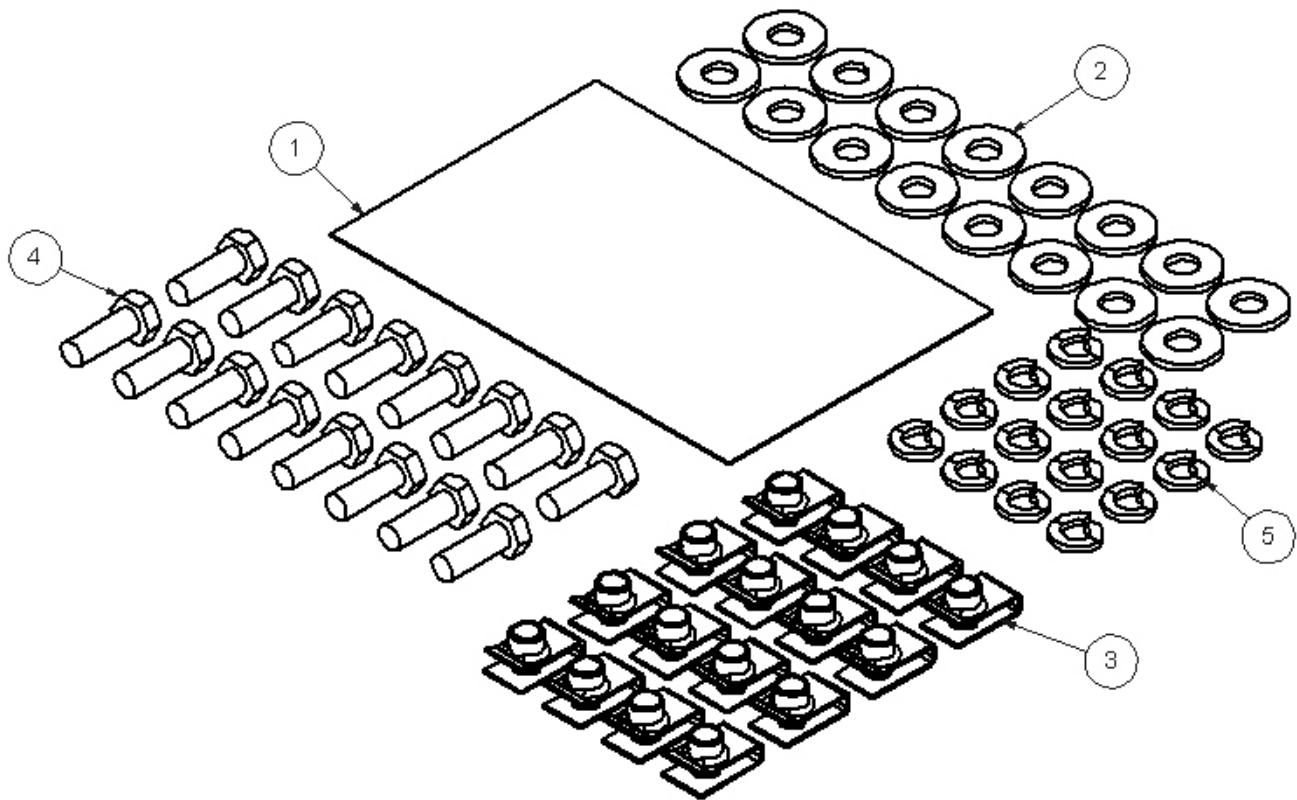

BAG50896 - FASTENER BAG, ROOF RAIL

ITEM NO.	PART NUMBER	DESCRIPTION	BAG50896/QTY.
1	BAG0406-A	4" x 6" 3MIL AUTOBAG	1
2	FAS0552	Washer, Flat, 5/16, SST	16
3	FAS0597	Screw, Hex Hd, 5/16-18x 1.00 SST	8
4	FAS0248	Nut, Nylon Insert Lock, 5/16-18 SST	16
5	FAS0808	Bolt, Carriage, 5/16-18x3 1/2	8

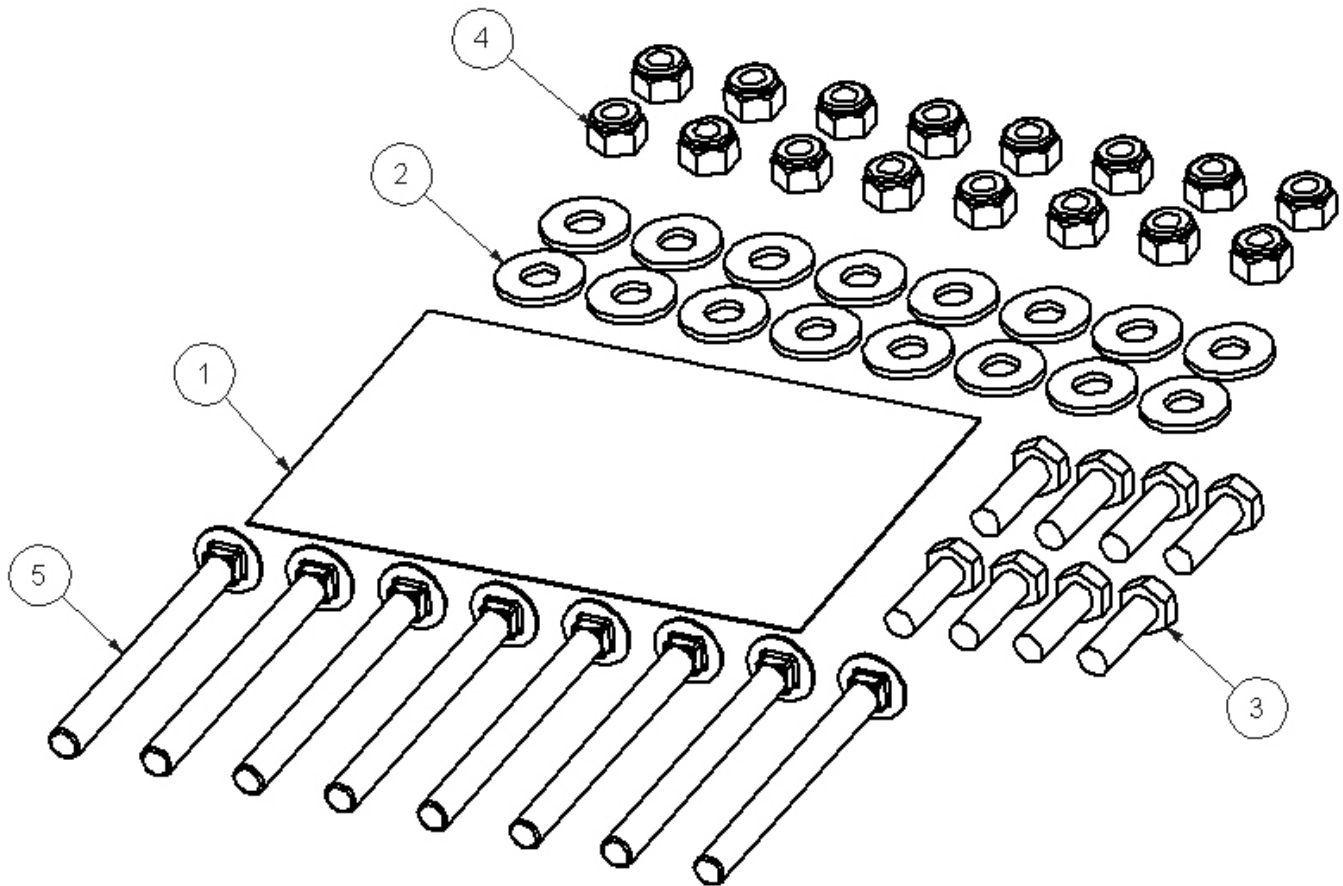



STEP #1 : FOLLOWING THE DROP DOWN OR GRIP LOCK INSTRUCTIONS, ASSEMBLE WHAT YOU CAN PRIOR TO INSTALLING ON THE VEHICLE. BELOW ARE A FEW EXAMPLES.

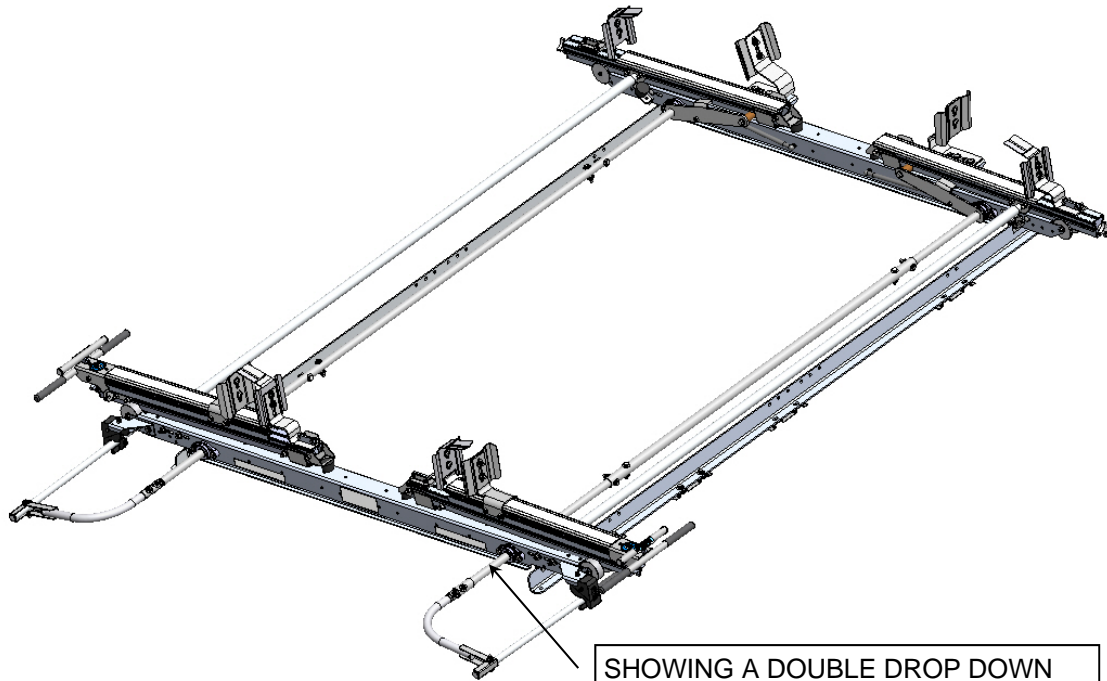

SHOWING A DOUBLE DROP DOWN LADDER RACK—DDL63NVL



SHOWING A DOUBLE GRIP LOCK LADDER RACK 63-GLNVL

STEP #2 : PREP ROOF RAILS—NISSAN LOW ROOF

52538 STREET SIDE ROOF RAIL
TOE UP TO THE INSIDE

REAR OF THE VAN
SHOWING LOW ROOF

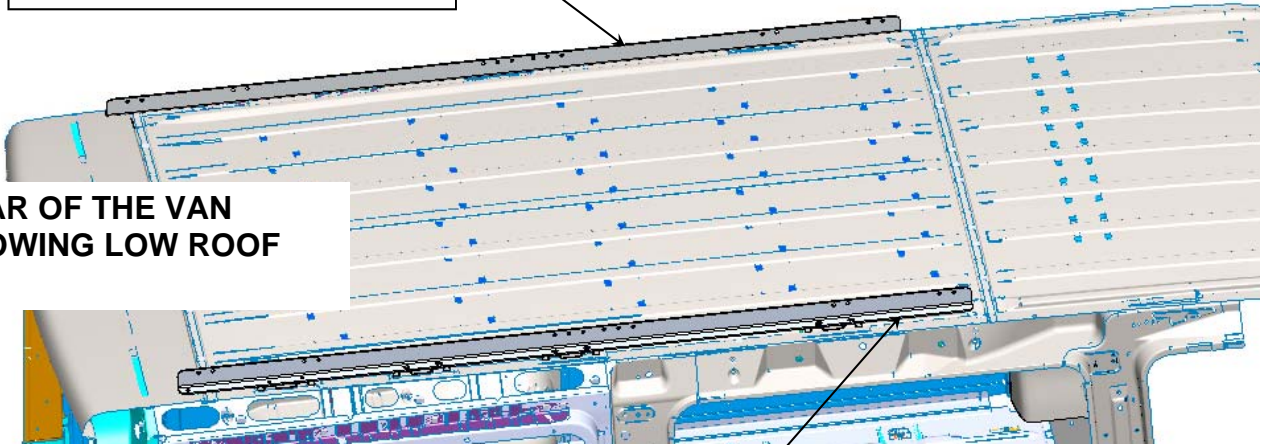

52537 CURB SIDE ROOF RAIL
TOE UP TO THE INSIDE

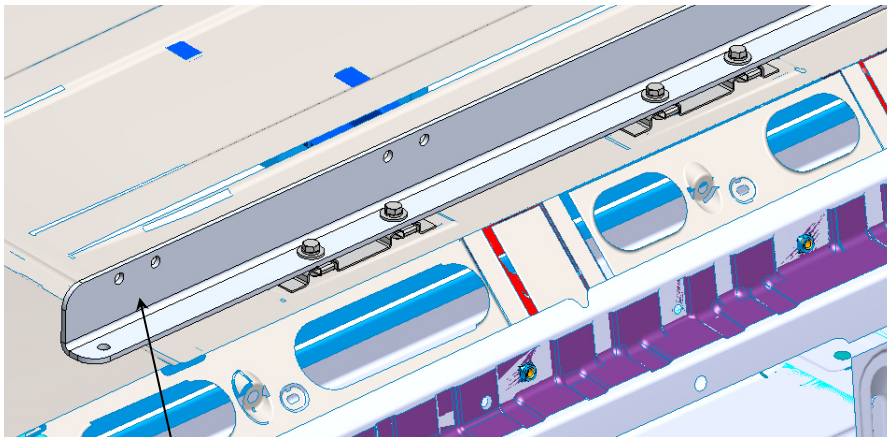

52537 CURB SIDE ROOF RAIL

FAS0283—5/16 X 7/8" LG HHCS (16)
FAS0588—LW (16)
FAS0552—FW (16)

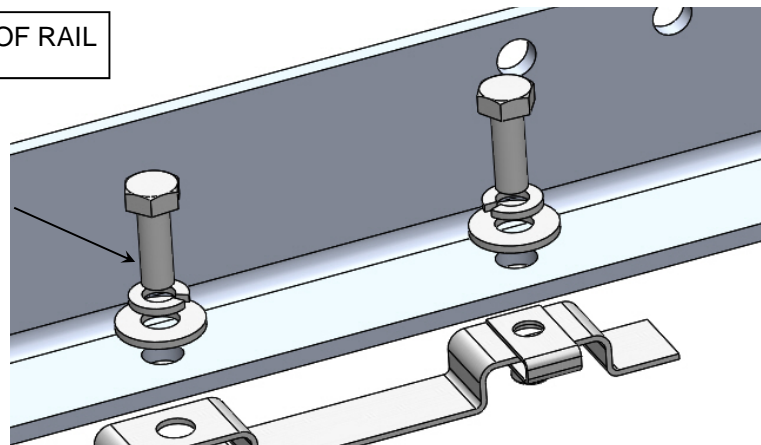

MOUNTING RAIL
ON THE VEHICLE

FAS0759—CLIP (16)

STEP #3 : ASSEMBLE REAR CROSS BOW TO THE ROOF RAILS

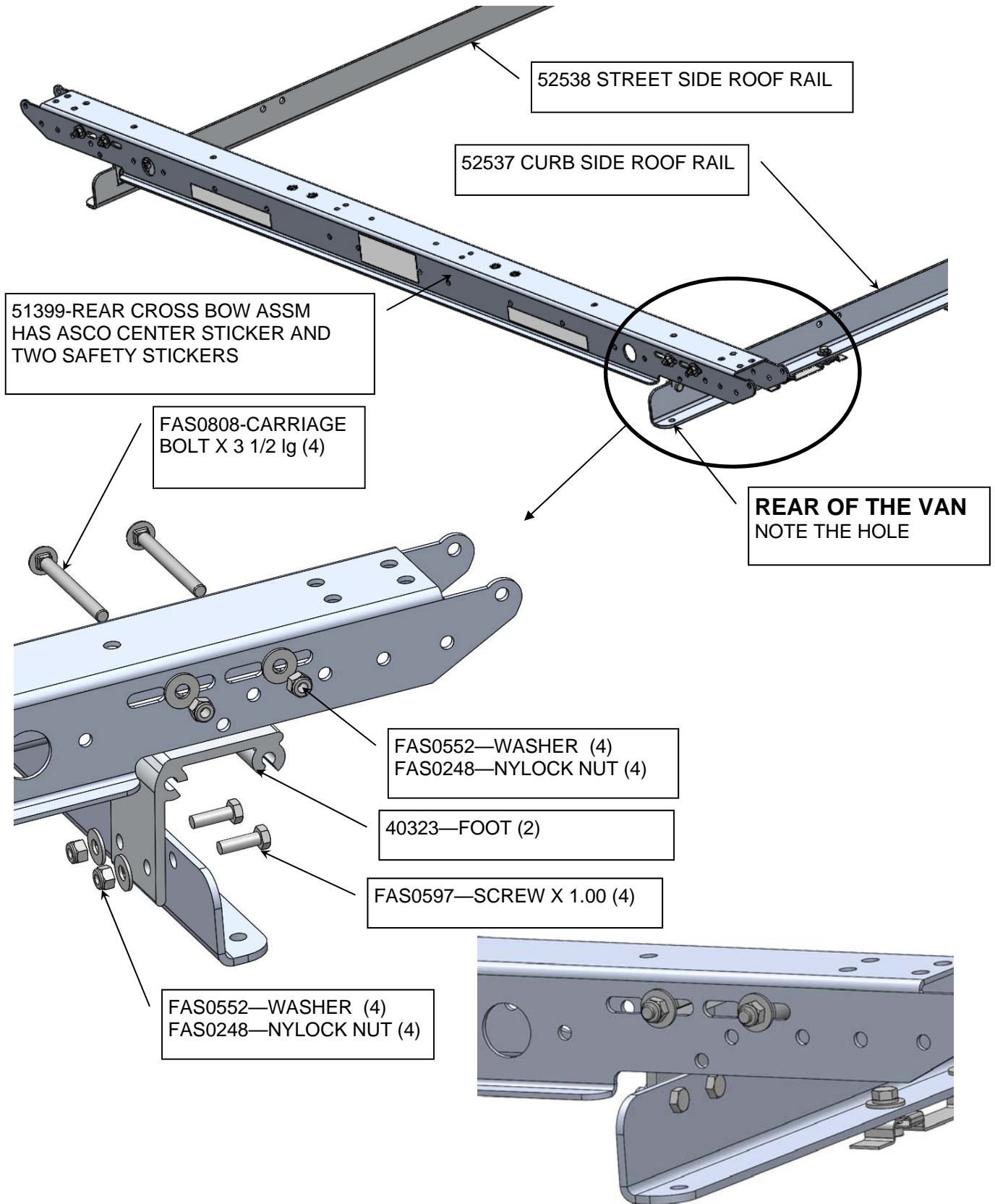

FEET ARE MOUNTED TO THE INSIDE OF THE ROOF RAIL

STEP #5 : ASSEMBLE FRONT CROSS BOW TO THE ROOF RAILS

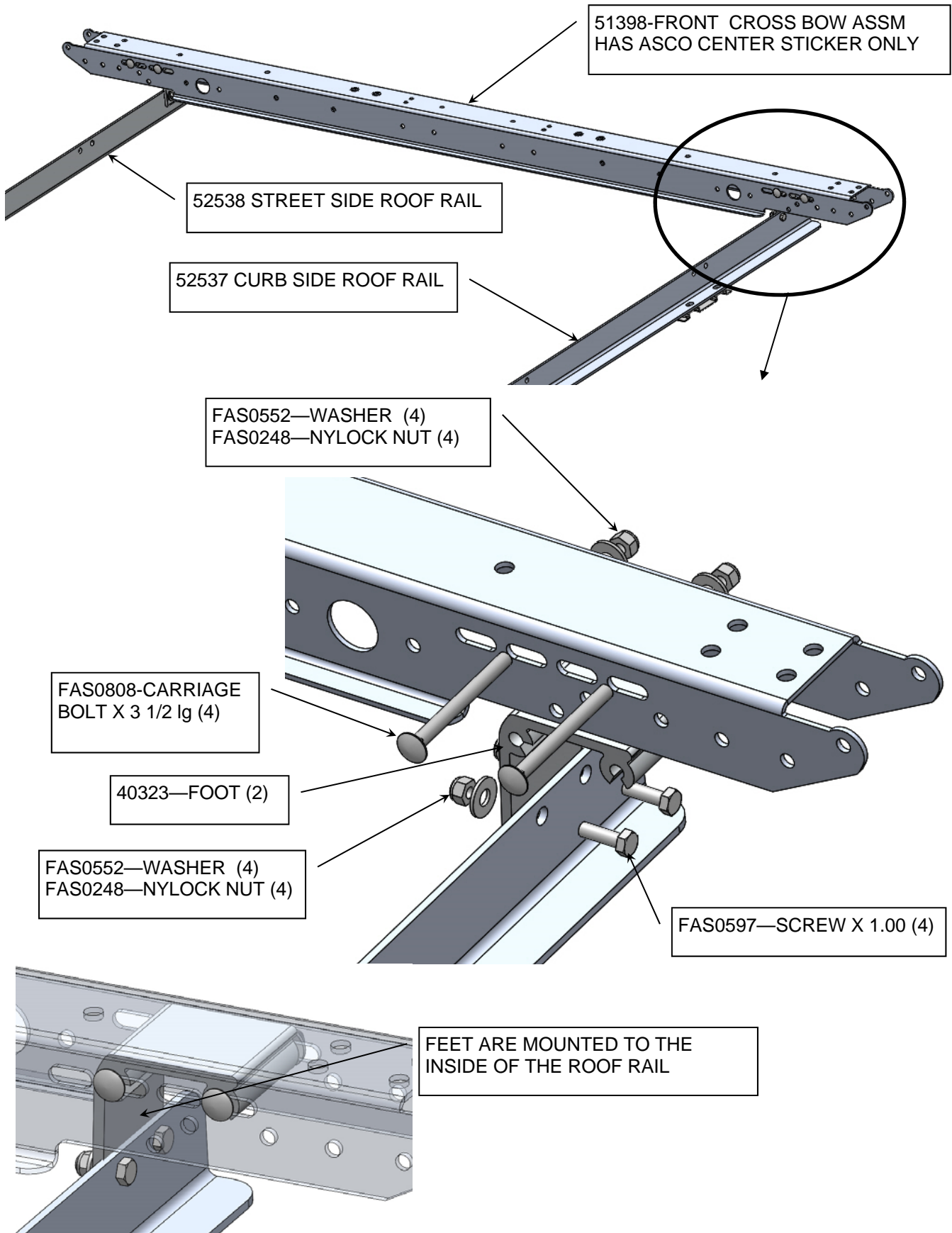

Introduction / Comments:

THIS GRIP LOCK IS DESIGNED TO ADAPT TO YOUR ROOF RAIL AND CROSS BOW KIT. SPECIFICALLY DESIGNED FOR THE LOW ROOF VEHICLES.

FOR A GM SIDE SLIDER DOOR, PLEASE ORDER A 55075 RISER KIT. THIS IS AVAILABLE UPON REQUEST. THESE FEET RAISE THE GRIP LOCK APPROX 2" AND CLEARS THE SIDE SLIDER DOOR. THIS ALSO COMES WITH A WIND DEFLECTOR AS RAISING THIS RACK CHANGED THE HARMONICS.

Note:

It is advised that all fasteners used in this assembly and installation of this Rack should be checked for tightness at the following intervals: @ 2-weeks and again @ 6-weeks of operation. This preventive maintenance step must be completed to ensure your package gives you long service life.

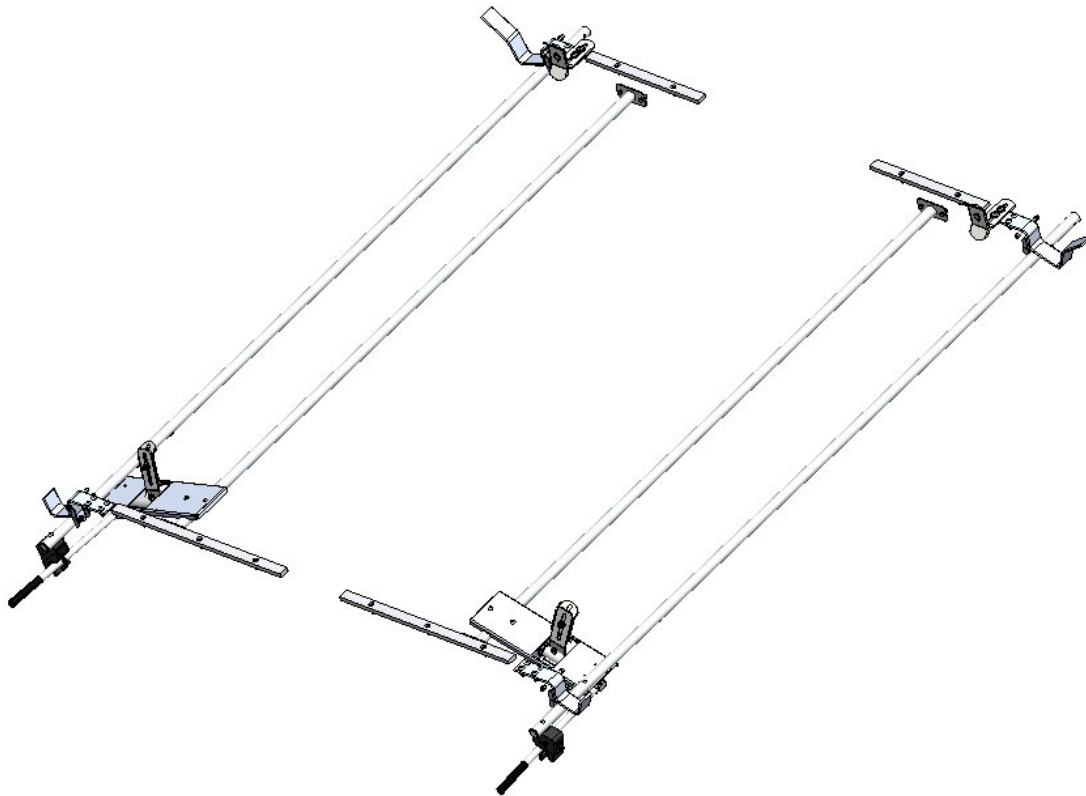

**61-GL2 SERIES / 63-GL2 SERIES
GRIP LOCK, SINGLE & DOUBLE
VARIOUS LOW ROOF VEHICLES**

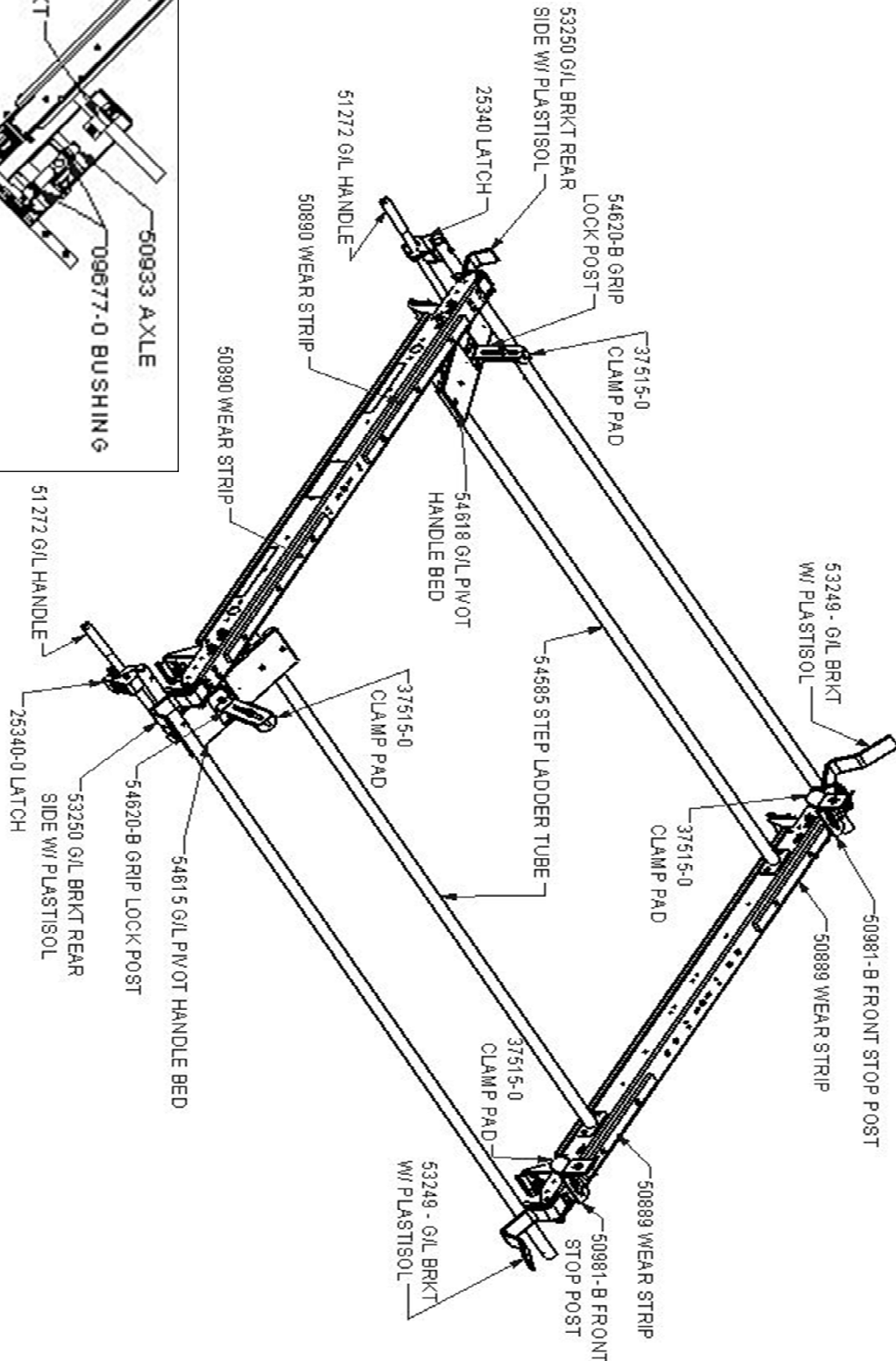
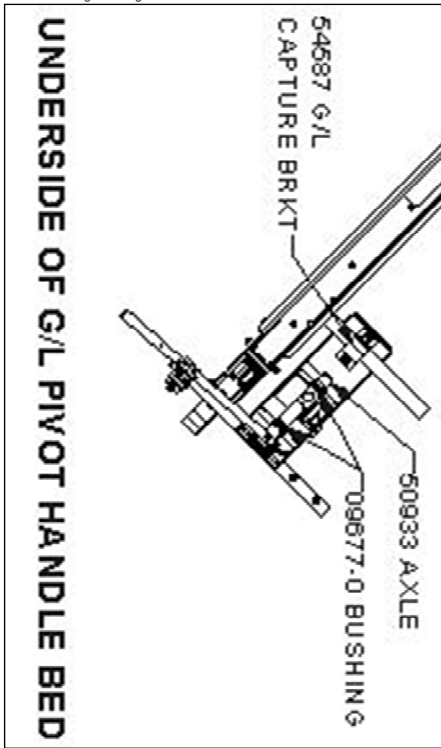

- PRECAUTIONS -



CAUTION
THE USE OF AIR IMPACT TOOLS CAN OVER-TORQUE FASTENERS AND CAUSE FASTENER FAILURE!



CAUTION
ALL INSTALLATION HOLES SHOULD BE SEALED WITH SILICON OR BUTYL SEALANT TO PREVENT EXHAUST FUMES FROM ENTERING THE VEHICLE!



DANGER
INSPECT FOR FUEL TANK, FUEL LINES, BRAKE LINES, HIGH VOLTAGE BATTERIES AND ELECTRICAL LINES PRIOR TO DRILLING TO AVOID DAMAGING CRITICAL VEHICLE SYSTEMS OR INJURY TO INSTALLER DURING INSTALLATION PROCESS!

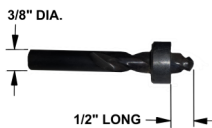

CAUTION
TO AVOID DAMAGING THE VEHICLE ALWAYS USE DRILL STOPS WHEN DRILLING ANY INSTALLATION HOLES!
ADRIAN AVAILABLE PART #'S 31119-0 (3/8" X 1/2" DEEP), 31121-0 (1/2" x 1/2" DEEP)



- IMPORTANT WARRANTY REQUIREMENTS -

1. SUBSTITUTING ADRIAN STEEL SPECIFIED FASTENERS FOR ASSEMBLY AND/OR INSTALLATION WILL VOID YOUR PRODUCT WARRANTY.
2. ALL HOLES DRILLED INTO VEHICLE SHOULD HAVE THE RAW METAL EDGES SEALED WITH A SELF-ETCHING PRIMER TO RESIST CORROSION AND POTENTIAL FASTENER POINT FAILURE.
3. ALL FASTENERS USED IN THE INSTALLATION OF THIS PRODUCT SHOULD BE TIGHTENED TO THE TORQUE(S) SPECIFIED IN THESE INSTRUCTIONS.
4. THESE INSTRUCTIONS SHOULD BE KEPT WITH THE VEHICLE.

THE BASIC TOOLS NEEDED FOR MOST INSTALLATIONS



DRILL

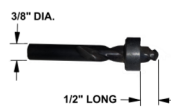

DRILL BIT WITH STOP

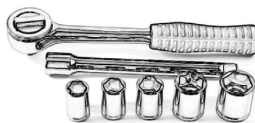

RATCHET, SOCKETS AND/OR WRENCHES



SCREWDRIVERS



MEASURING TAPE

ADDITIONAL TOOLS MAY BE NEEDED FOR THIS INSTALLATION AND THEY WILL BE IDENTIFIED IN THE STEPS THAT FOLLOW.

BAG54629 - FASTENER BAG

ITEM NO.	PART NUMBER	DESCRIPTION	QTY.
1	BAG0507-A	5" x 7" 3MIL AUTOBAG	1
2	FAS0248	Nut, Nylon Insert Lock, 5/16-18 SST	13
3	FAS0811	SCREW,CAP, 5/16-18X3.50 SS	2
4	FAS0813	Screw, BHCS, 5/16-18X1.00, SS	9
5	FAS0799	Screw, Hex Hd, 5/16-18x0.75 SS	4
6	FAS0552	Washer, Flat, 5/16, SST	4
7	FAS0820	SCREW,BHCS 3/8-16X1.0 SS	6
8	FAS0110	Nut,Hex Nylk 3/8-16 SS W	8
9	FAS0701	Screw,BHCS 3/8-16x1.25 SS	2
10	FAS 0720	Washer,Flat 3/8 SS	2
11	FAS0588	Washer, Lock, Split, 5/16, SS	2

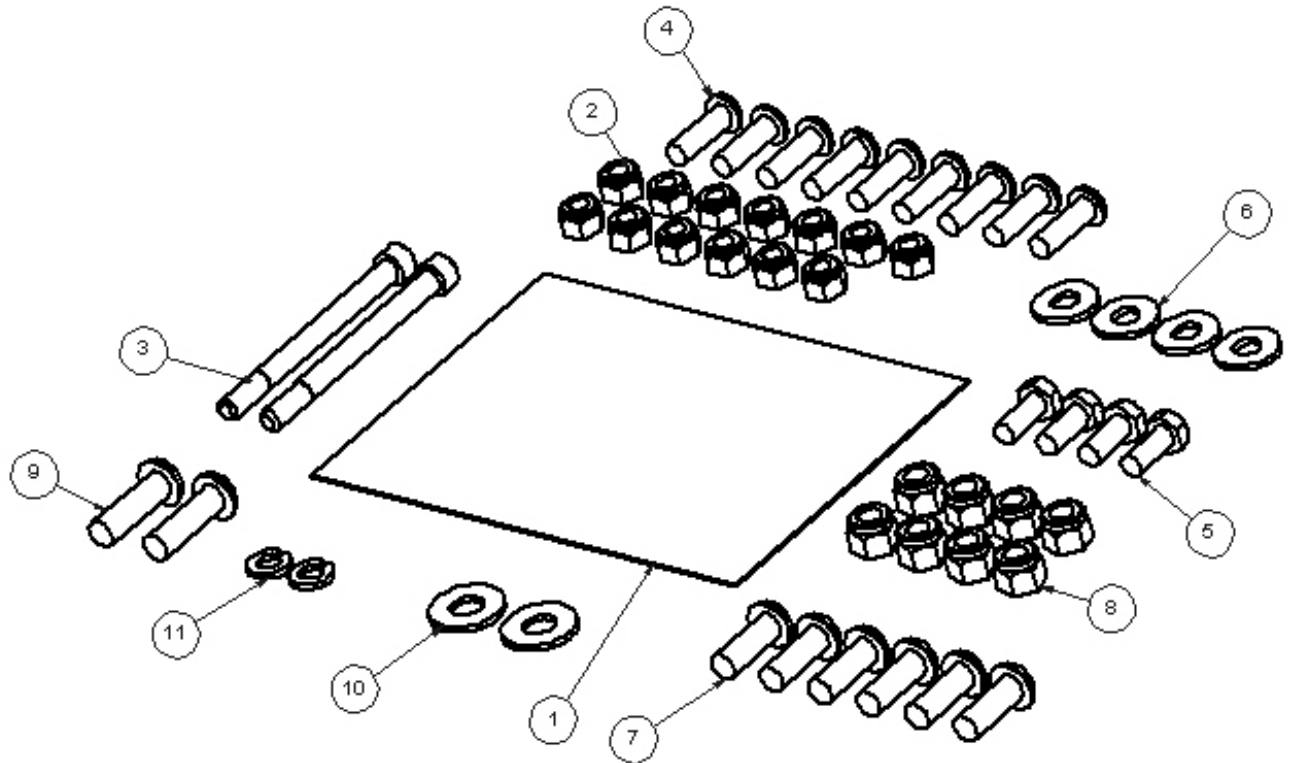



**STEP #1A : ASSEMBLE CURB SIDE WEAR STRIPS TO THE ROOF BOWS
ALL RACKS**

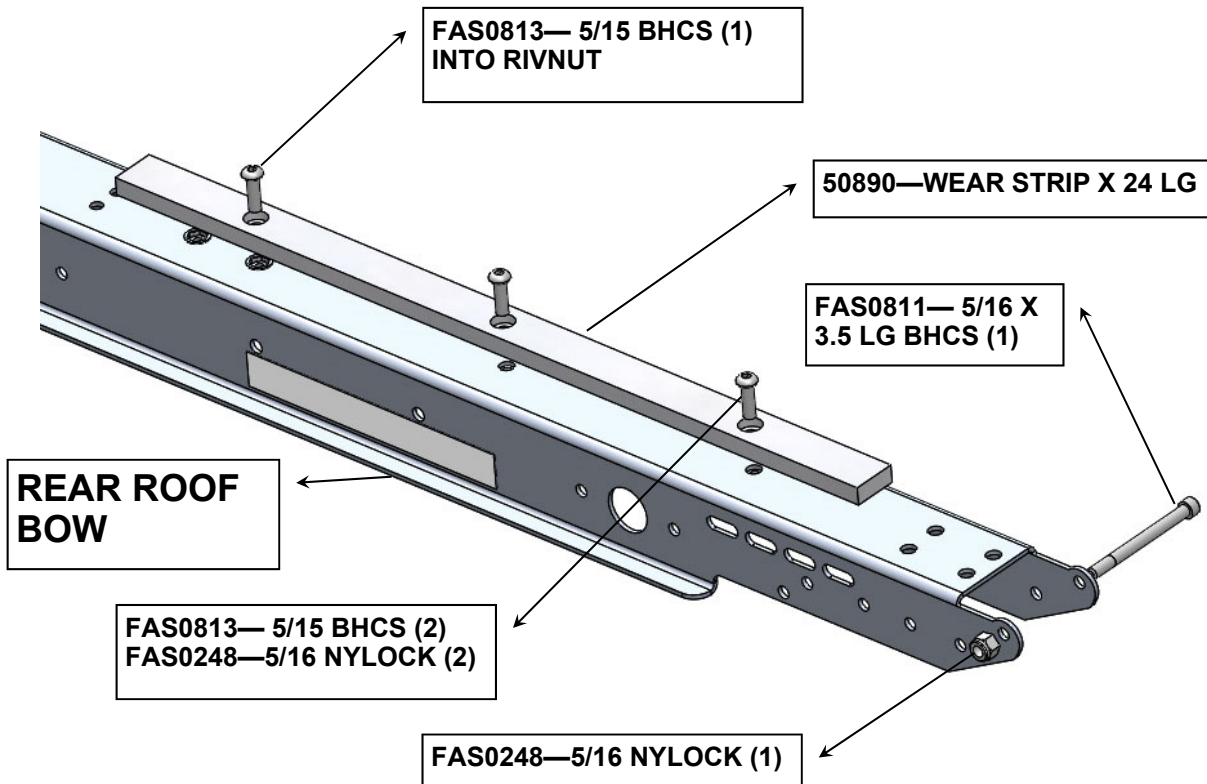
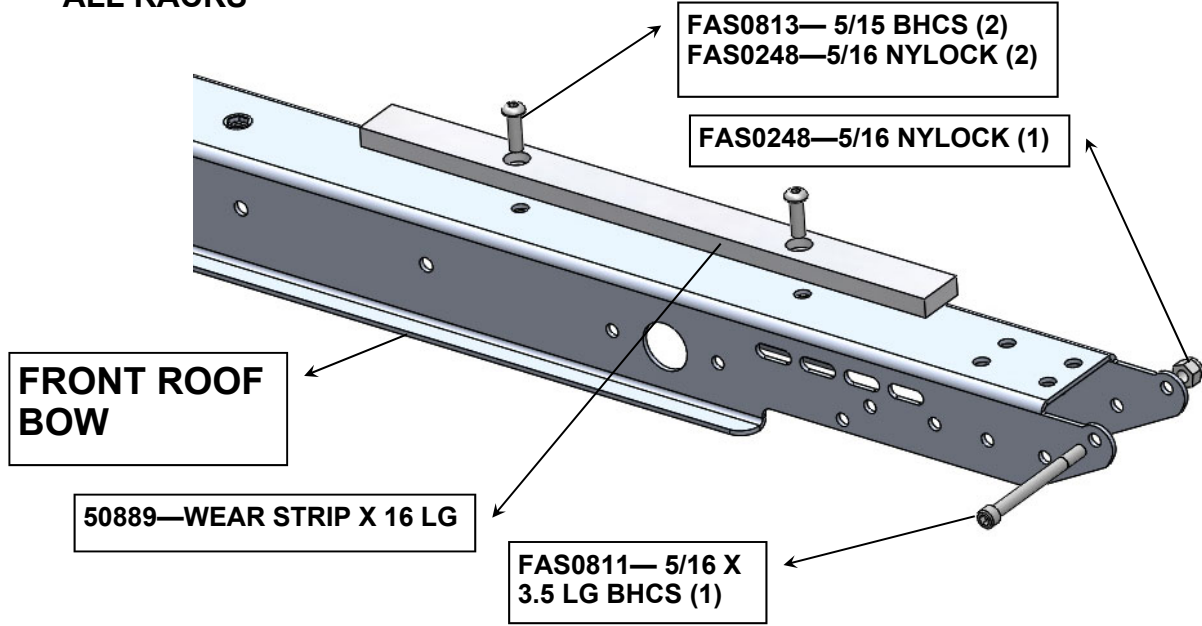



**STEP #1B : THIS IS THE FINISHED CURB SIDE ASSEMBLY FOR A FORD TRANSIT SHIP THRU RACK.
CONTINUE TO STEP #3 FOR A DOUBLE GRIP LOCK (ANOTHER KIT)
PLACE ASSEMBLED CROSS BOWS FROM STEP #1 BACK IN HDW BOX**

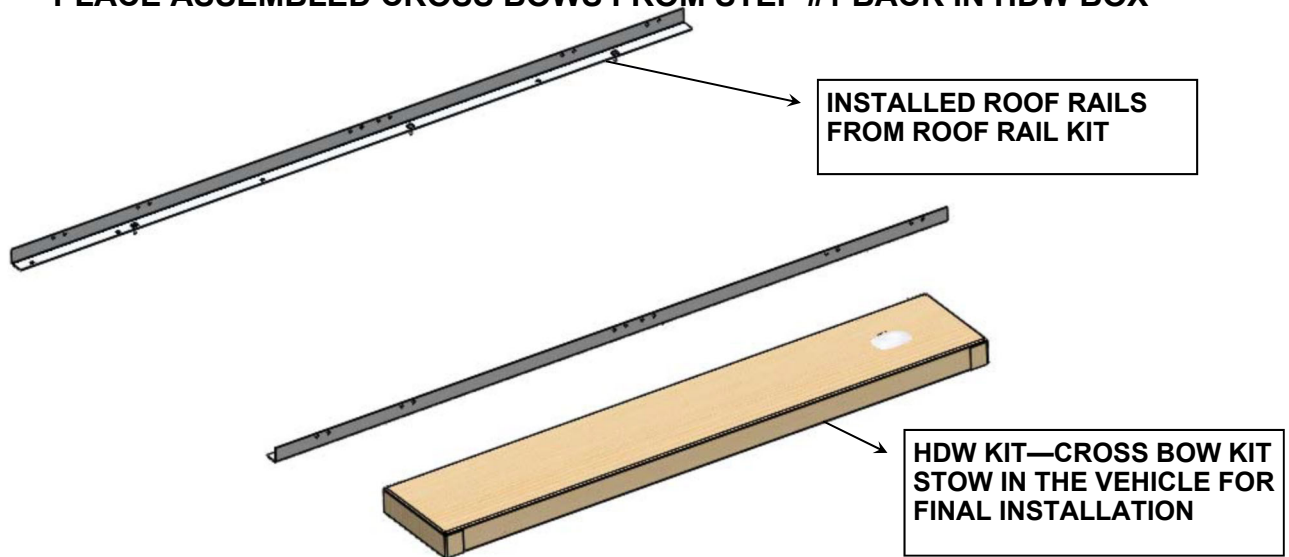

**STEP #2A : ALL RACKS, ASSEMBLE STREET SIDE WEAR STRIPS TO THE ROOF BOWS.
THIS IS ALL THAT CAN BE INSTALLED FOR THE TRANSIT SHIP THRU—
STOW THE REMAINDER OF THE PARTS FOR FINAL INSTALL.**

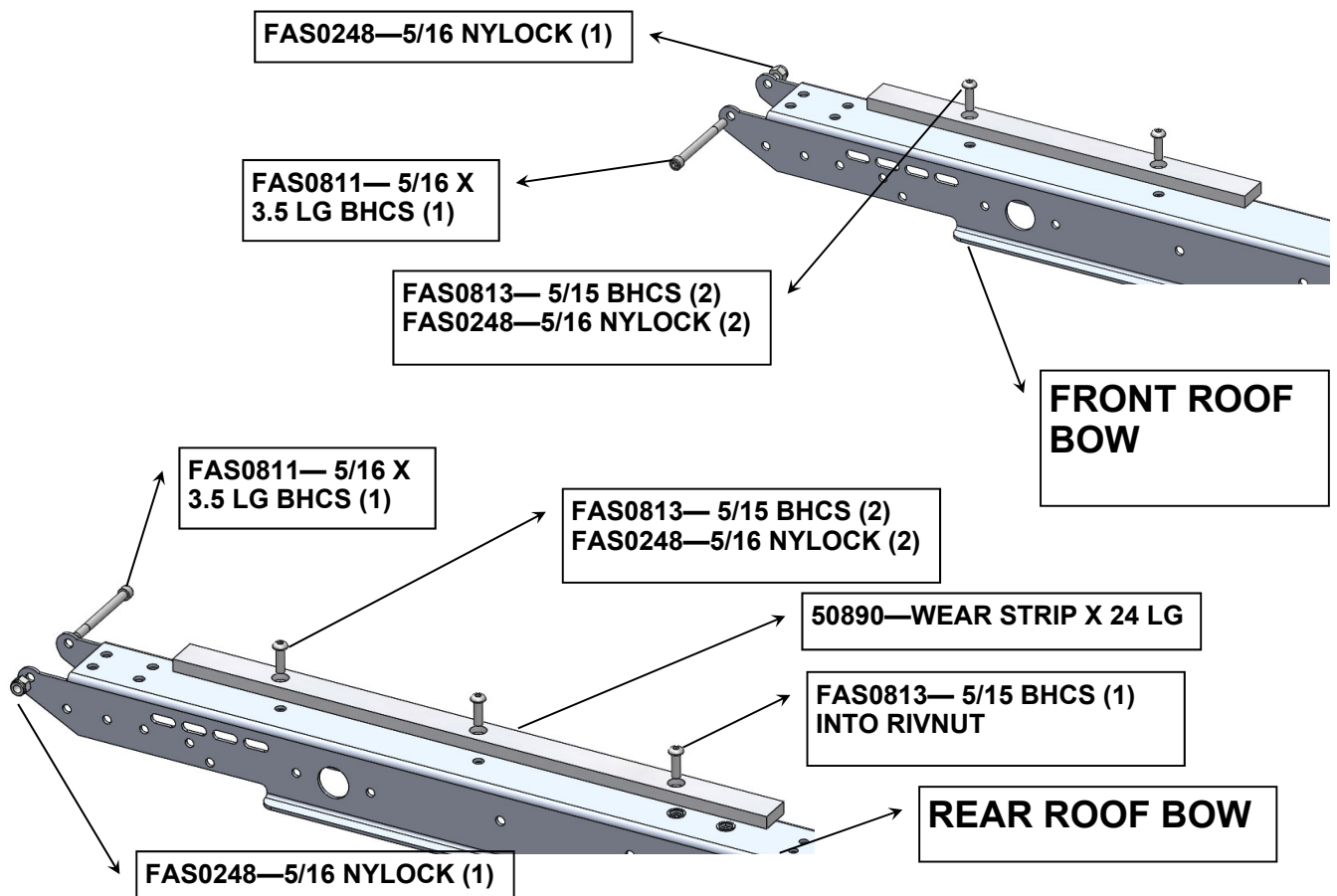



**STEP #2B : FOR A FORD TRANSIT SHIP THRU ONLY—THIS IS THE COMPLETED ASSEMBLY OF A DOUBLE GRIP LOCK.
PLACE ASSEMBLED CROSS BOWS FROM STEP #1 & 3 BACK IN HDW BOX
CONTINUE TO STEP 5 FOR A COMPLETE ASSEMBLY / INSTALL**

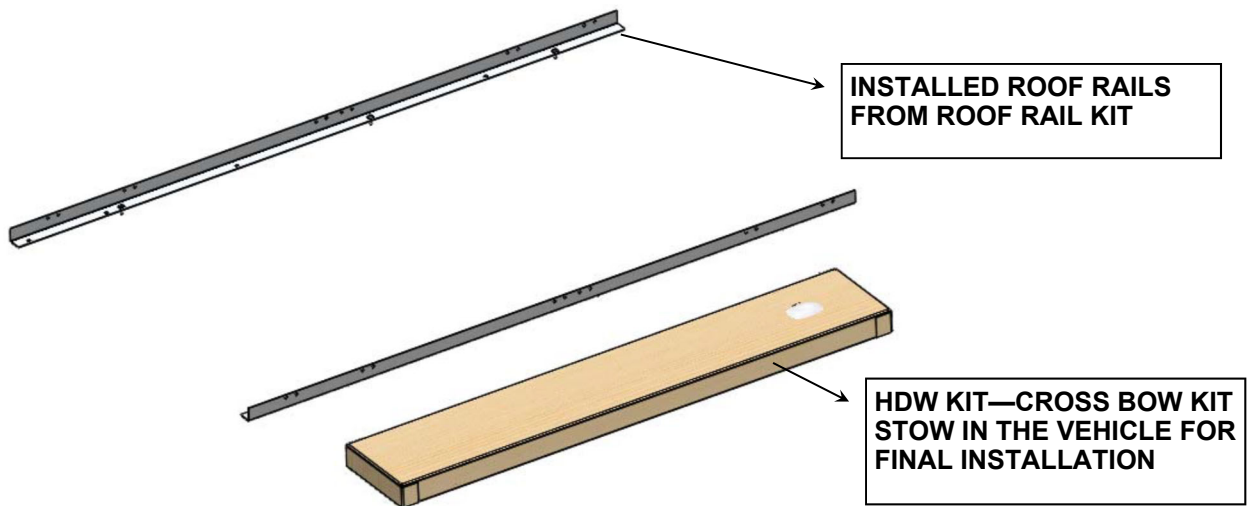

**STEP #3A : GM SHIP THRU ONLY—SINGLE GRIP LOCK
THIS IS THE COMPLETED ASSEMBLY**

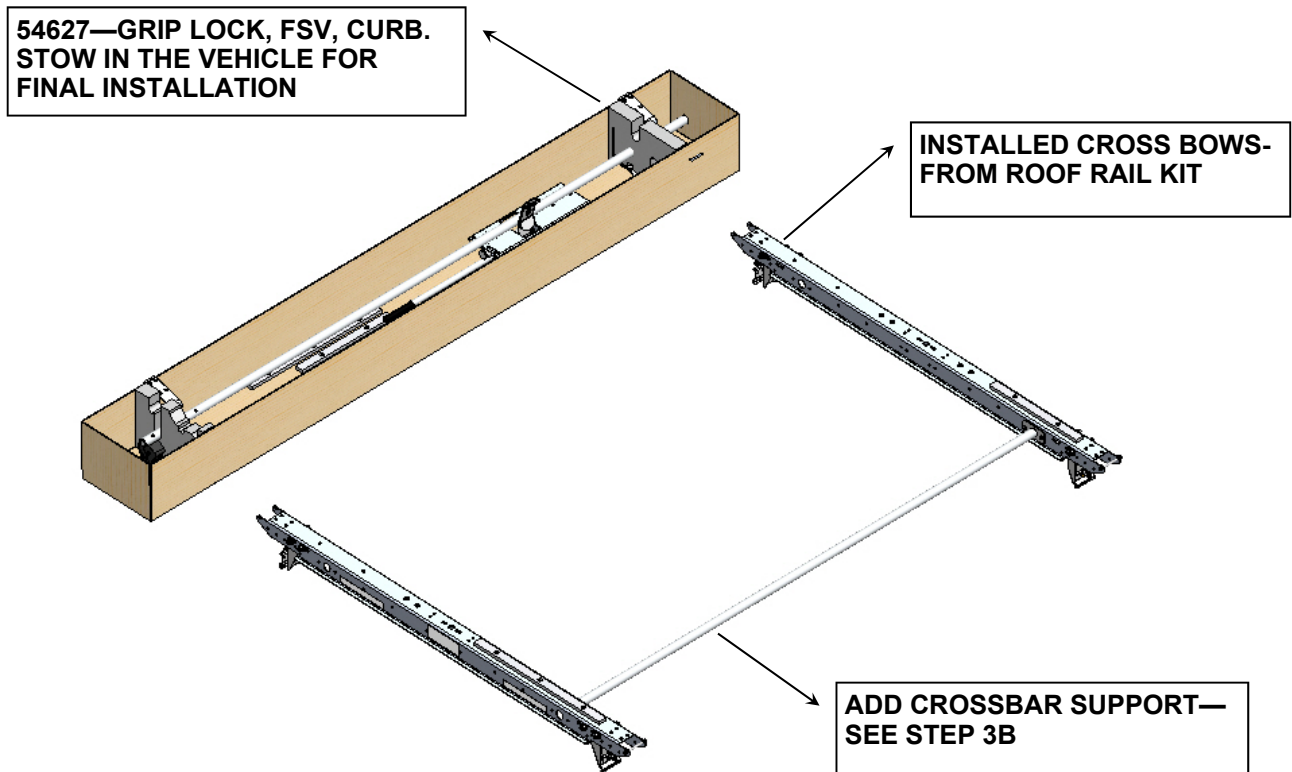



STEP #3B: ADD CROSS SUPPORT FOR SLIDE BED

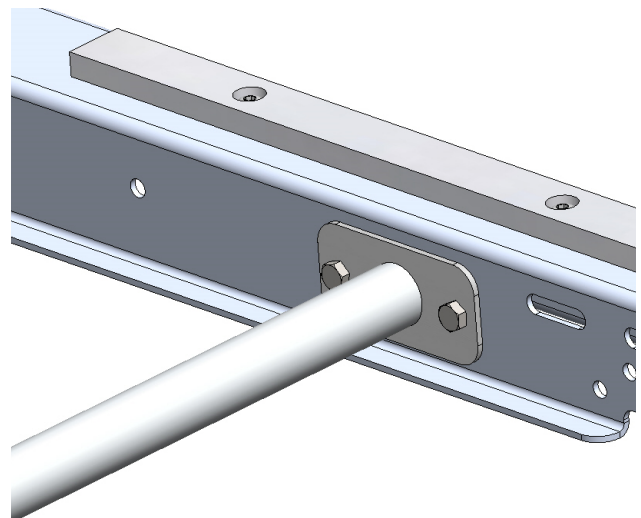
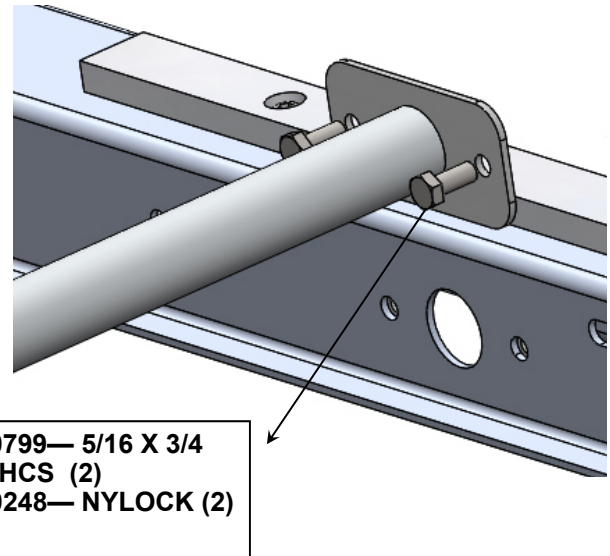
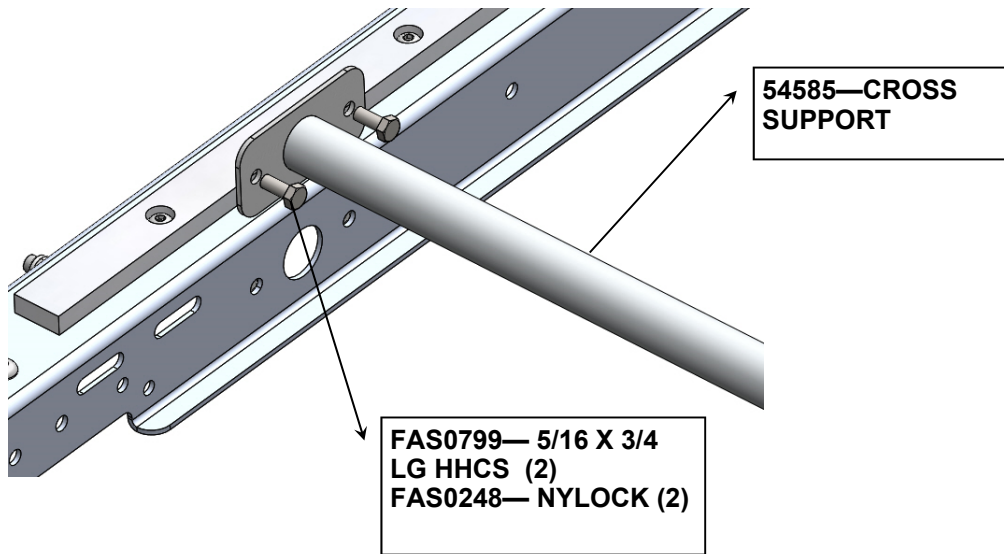



**STEP #4A : GM SHIP THRU ONLY—DOUBLE GRIP LOCK
THIS IS THE COMPLETED ASSEMBLY**

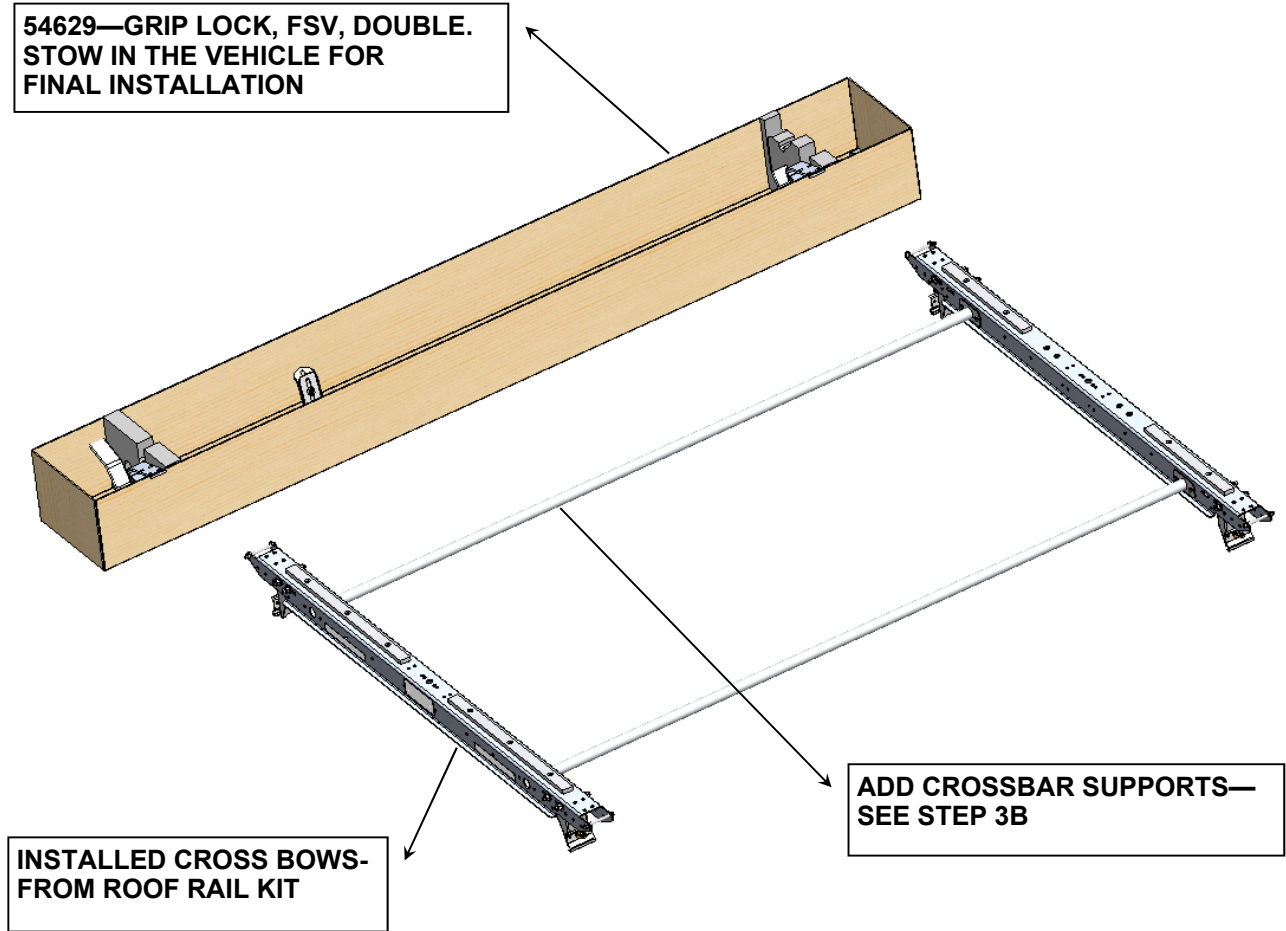

STEP #5 : INSTALL CURB SIDE SUB ASSEMBLY ON THE ROOF BOWS

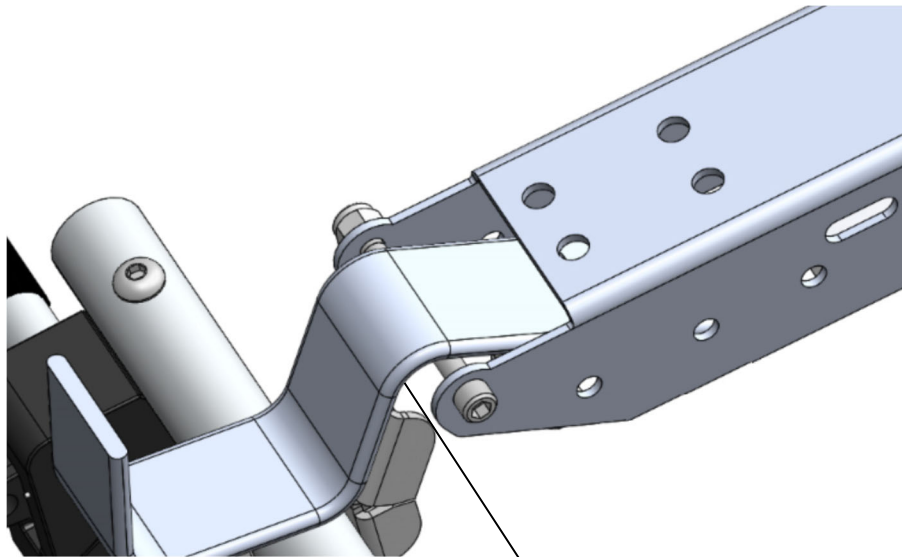

**PIVOT AND PUT
GRIP LOCK HOOKS
INTO ROOF BOWS**

REAR ROOF BOW

**FAS0820— 3/8 X 1
LG BHCS (4)
FAS0110— NYLOCK (4)**

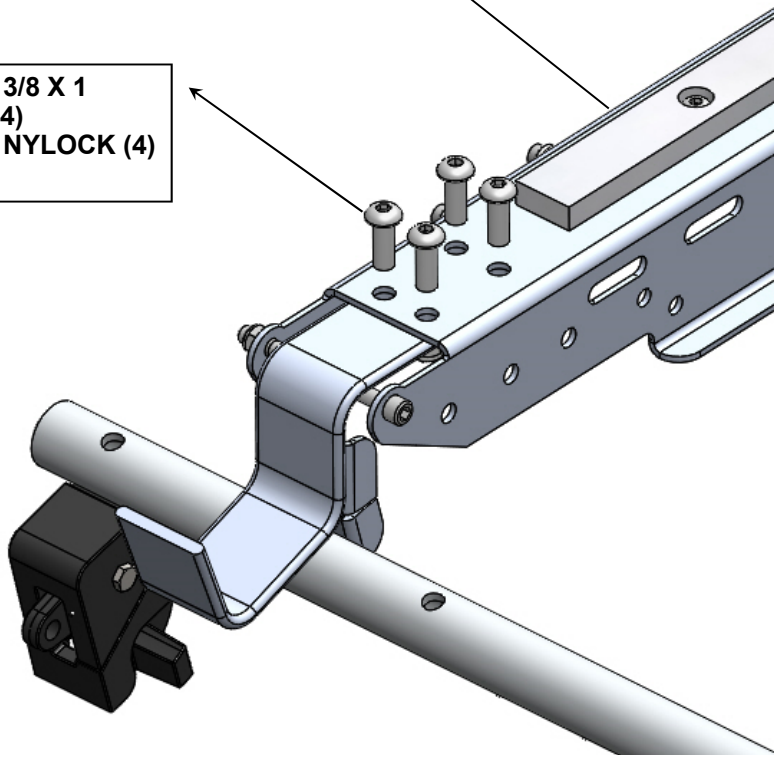

STEP #6: FRONT ROOF BOW ASSEMBLY –CURB SIDE

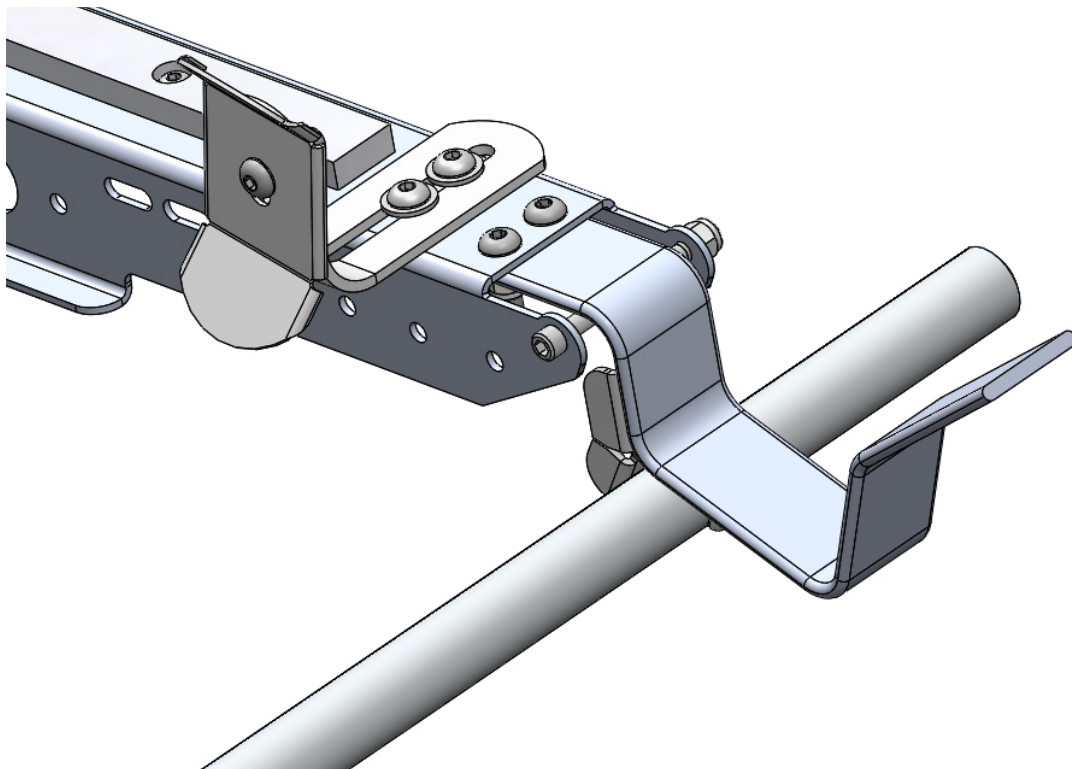
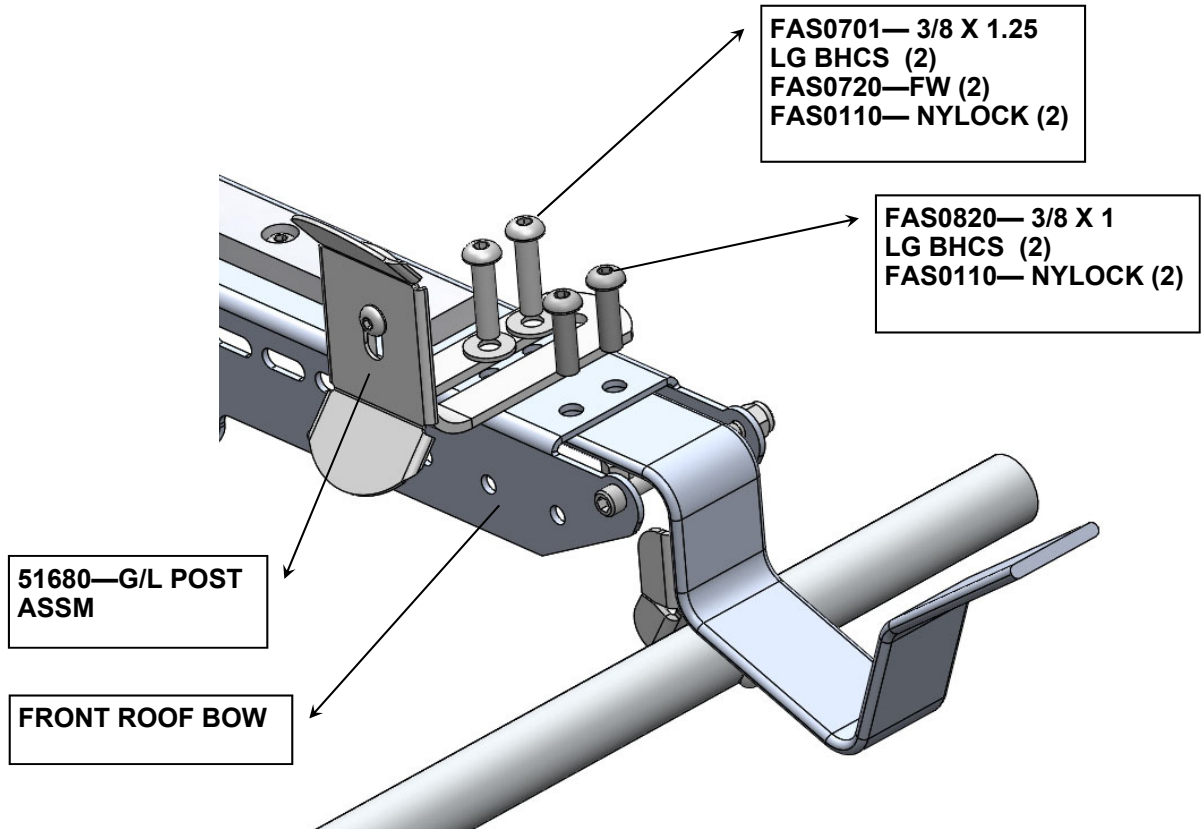



STEP #6: ADD CROSS SUPPORT FOR SLIDE BED –CURB SIDE

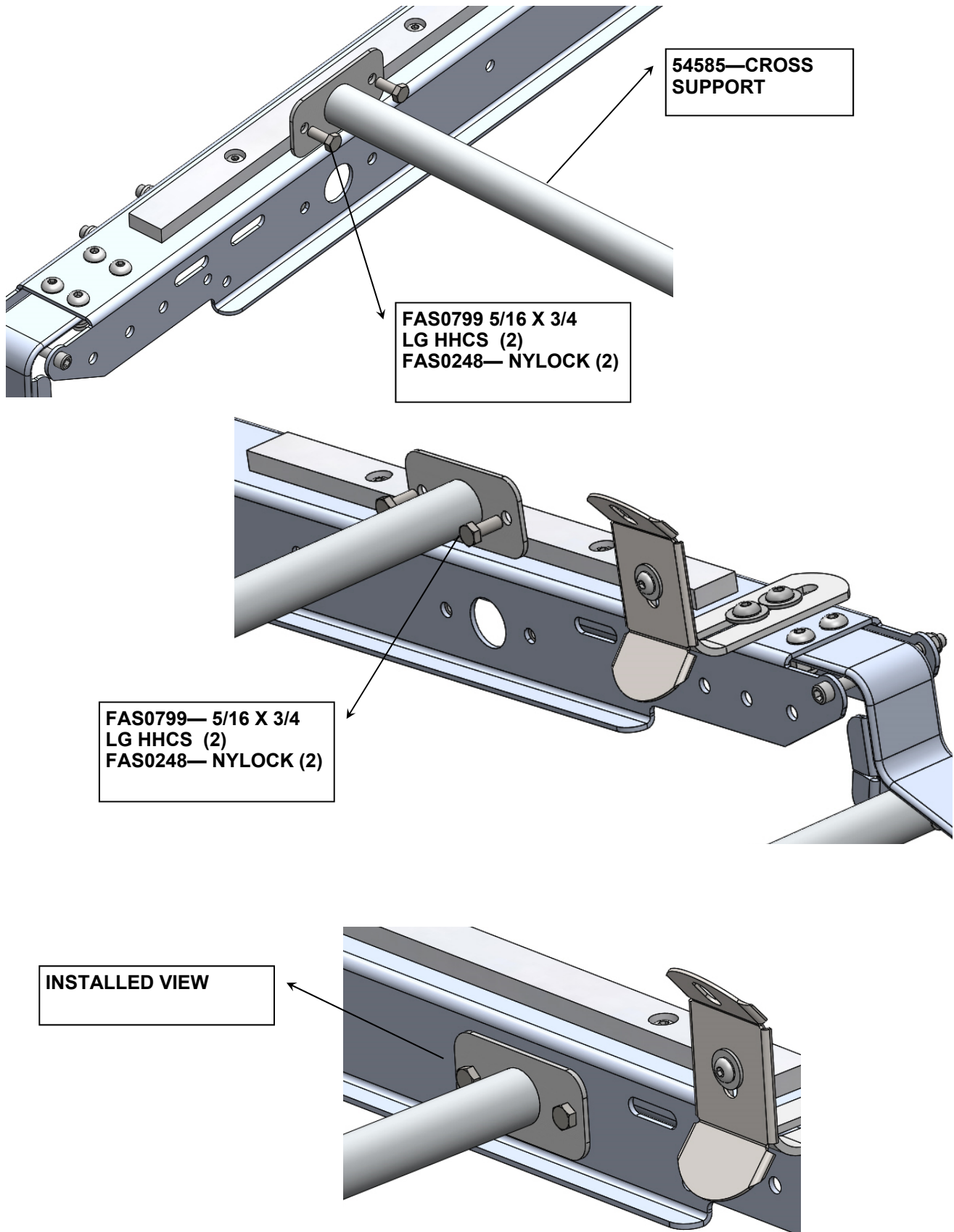



STEP #7A: EXTENSION LADDER—ADD BED SLIDE TO THE CROSS SUPPORT – CURB SIDE.

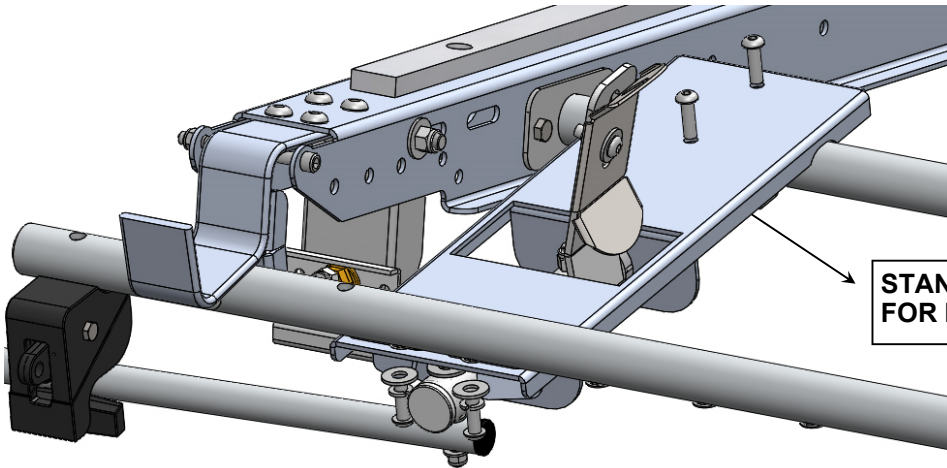

STANDARD LOCATION FOR EXTENSION LADDERS

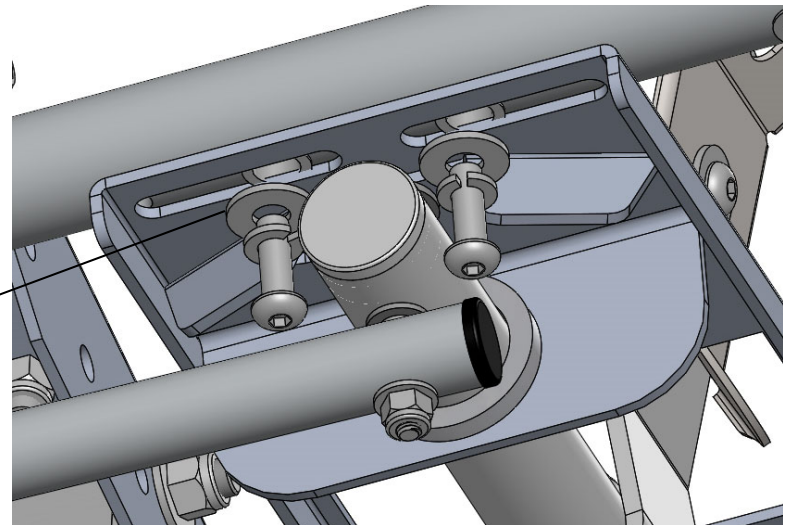

**FAS0813— 5/16 X1 LG BHCS (2)
FAS0588-LW (2)
FAS0552— FW (2)**

**FAS0813— 5/16 X1 LG BHCS (2)
FAS0552— FW (2)
FAS0248-NYLOCK (2)**

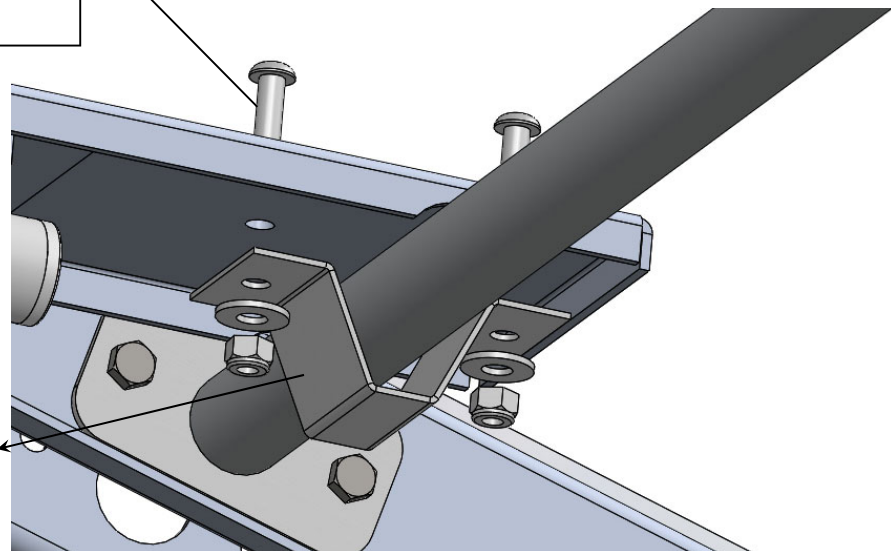

54587—CAPTURE BRACKET



**STEP #7B: A-FRAME LADDER— ADD BED SLIDE TO THE CROSS SUPPORT
—CURB SIDE.**

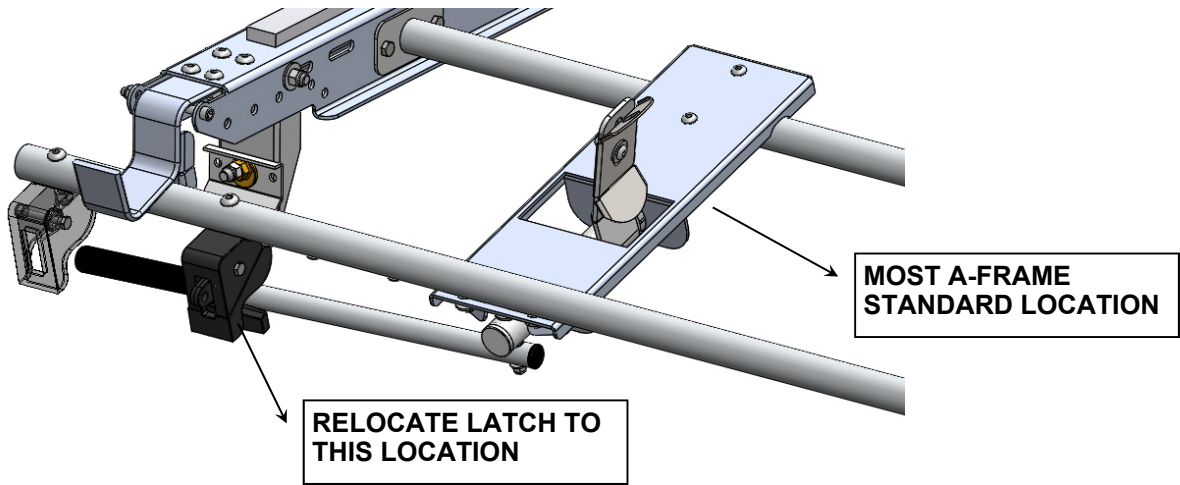

ANOTHER OPTIONAL MTG LOCATION

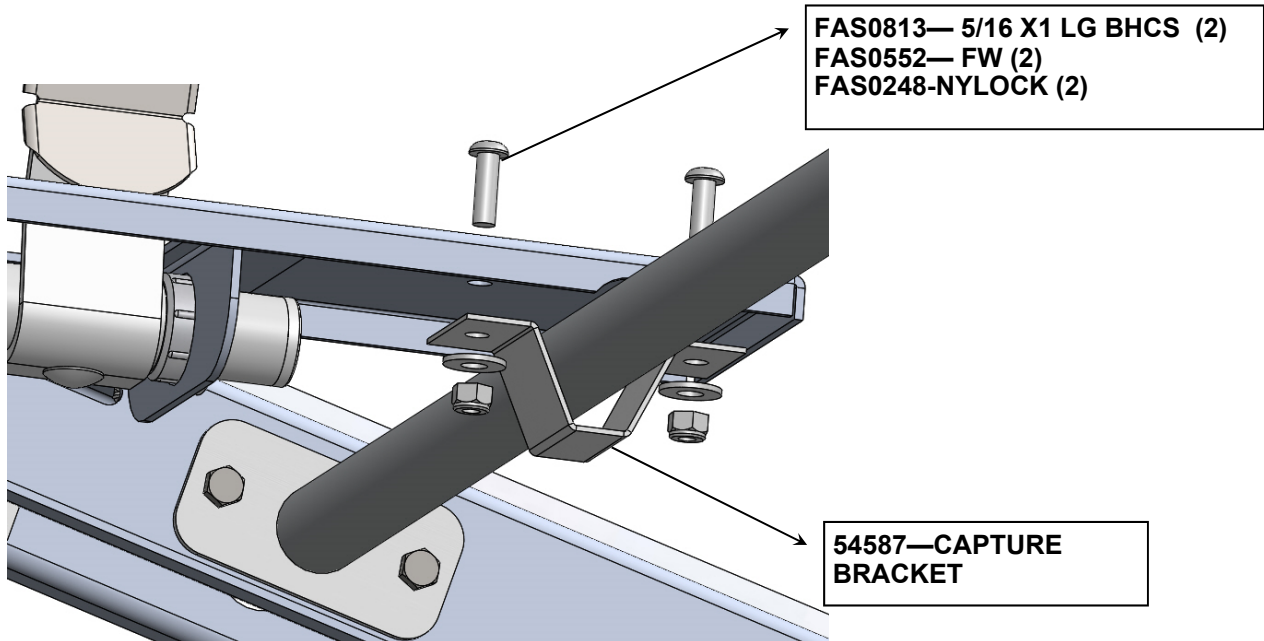
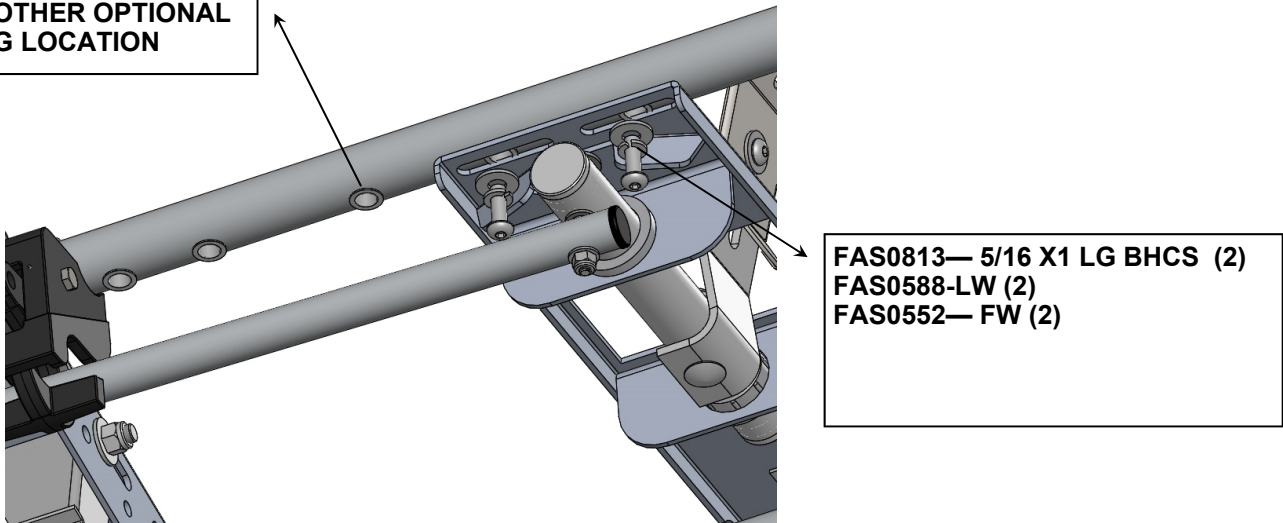



STEP #8: FOLLOW STEPS 1 THRU 7 FOR YOU STREET SIDE ASSEMBLY

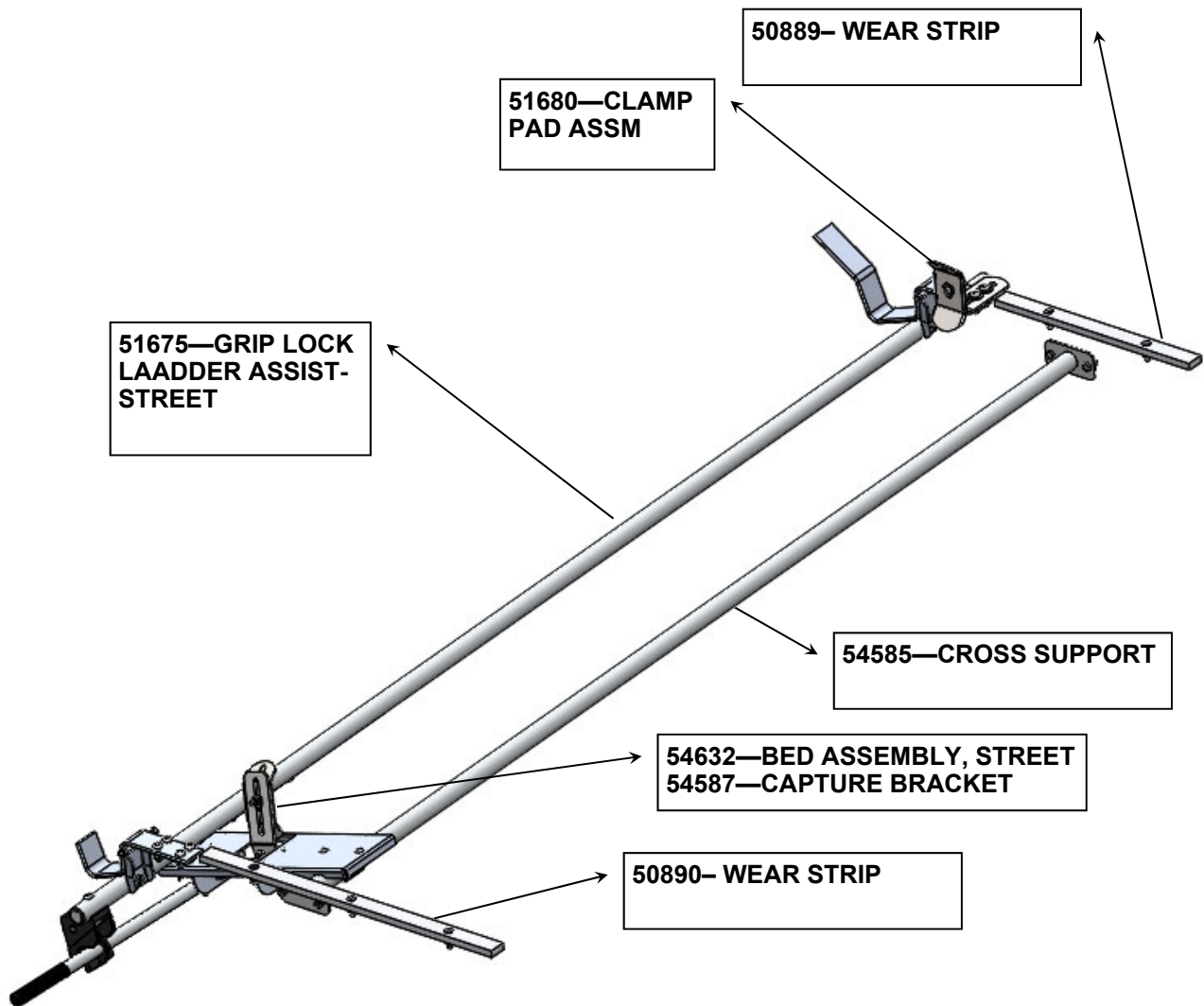

**DOUBLE CHECK ALL FASTENERS LOCATIONS TO BE SURE THAT ALL
FASTENERS ARE TIGHTENED TO SPECIFICATIONS.
YOUR INSTALLATION IS NOW COMPLETE!
STOW THIS COPY IN THE VEHICLE FOR FUTURE REFERENCES!**



STEP #9: YOUR ASSEMBLY IS NOW COMPLETE

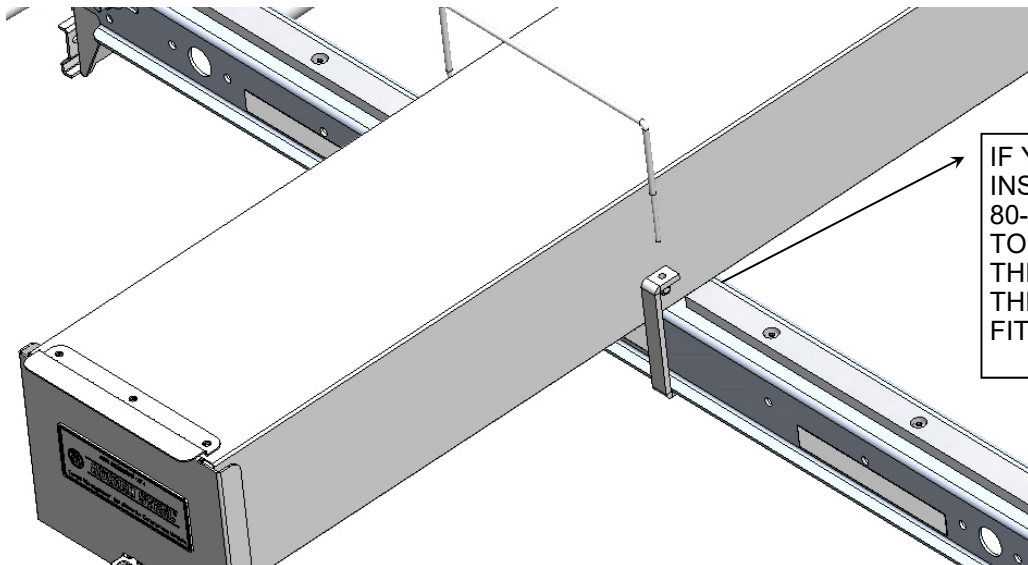
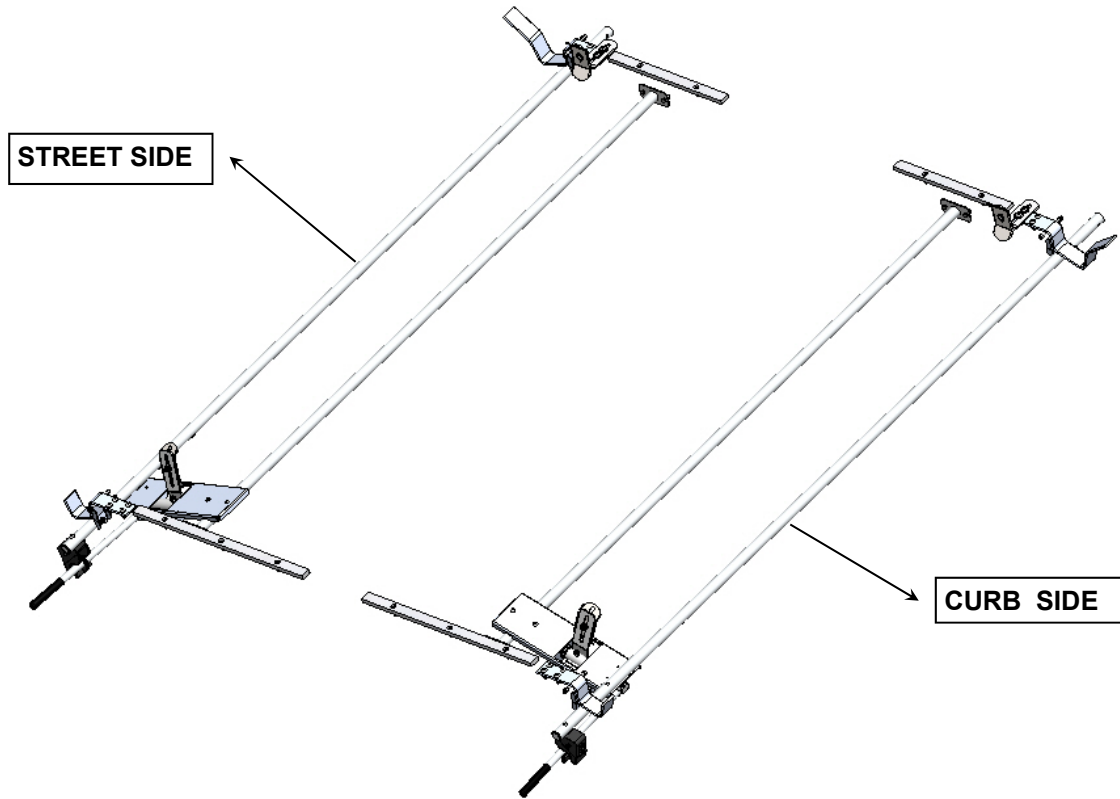

**DOUBLE CHECK ALL FASTENERS LOCATIONS TO BE SURE THAT ALL FASTENERS ARE TIGHTENED TO SPECIFICATIONS.
YOUR INSTALLATION IS NOW COMPLETE!
STOW THIS COPY IN THE VEHICLE FOR FUTURE REFERENCES!**



STEP #10A: HOW TO ADJUST THE CLAMP PADS



FRONT BRACKET

ADJUST VERTICALLY TO YOUR LADDER

ALL OF THE HORIZONTAL ADJUSTMENT IS IN THIS BRACKET.

ADJUST VERTICALLY TO YOUR LADDER. SHOWING A STEP LADDER

SLOTS FOR ADJUSTMENT

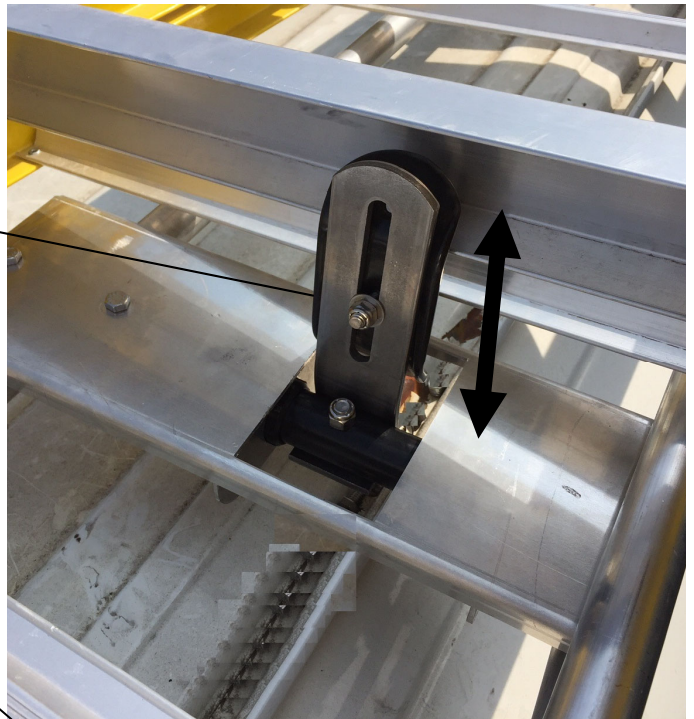

LOOSEN FASTENERS TO ADJUST CLAMP

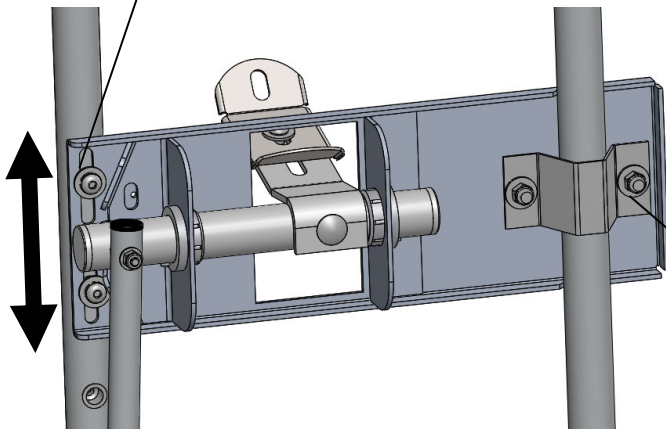

**DOUBLE CHECK ALL FASTENERS LOCATIONS TO BE SURE THAT ALL FASTENERS ARE TIGHTENED TO SPECIFICATIONS.
YOUR INSTALLATION IS NOW COMPLETE!
STOW THIS COPY IN THE VEHICLE FOR FUTURE REFERENCES!**



STEP #10B : HOW TO ADJUST THE CLAMP PADS

- A) Load your ladder onto the ladder rack (see page 14) and latch the HANDLE BAR into the HANDLE LATCH.
- B) Now slide the ladder back towards the rear of the vehicle and slide the rear CLAMP BRACKET to fit snug over and against the top ladder rung. ** See bottom illustration for STEP LADDERS ! **
SEE ILLUSTRATION BELOW.
- C) Next slide the FRONT STOP POST at the front of the ladder rack back towards the rear of the vehicle and fit the front CLAMP BRACKET to the top ladder rung the same as the rear.
- D) Firmly tighten both front and rear CLAMP BRACKETS to their posts and tighten snug the FRONT STOP POST to the front CROSS SUPPORT.
- E) Now unlatch the HANDLE BAR and unload your ladder. Next loosen the FRONT STOP POST and slide it out towards the rear of the vehicle 1/2" and FIRMLY RETIGHTEN !
YOUR LADDER RACK SHOULD NOW BE ADJUSTED FOR YOUR LADDER.

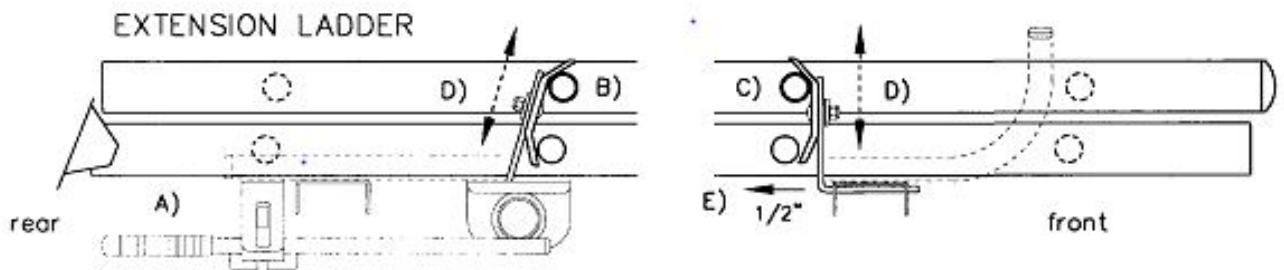

CAUTION: Never clamp up the first step and the head of the STEP LADDER !

Front CLAMP BRACKET must be attached like this !

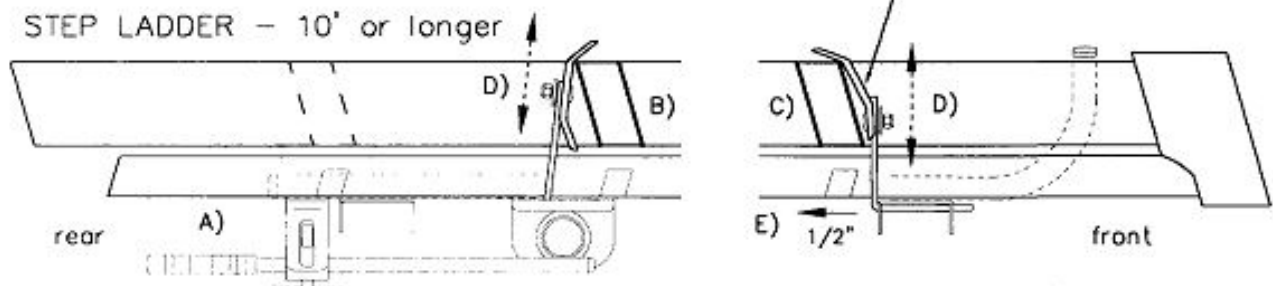

**DOUBLE CHECK ALL FASTENERS LOCATIONS TO BE SURE THAT ALL FASTENERS ARE TIGHTENED TO SPECIFICATIONS.
YOUR INSTALLATION IS NOW COMPLETE!
STOW THIS COPY IN THE VEHICLE FOR FUTURE REFERENCES!**