

Introduction / Comments:

This instruction shows proper installation into a F-150 aluminum truck body. **This instruction supersedes other installation methods when mounting to an aluminum F-150 truck body.**

Note:

It is advised that all fasteners used in this assembly and installation should be checked for tightness at the following intervals: @ 2-weeks and again @ 6-weeks of operation. This preventive maintenance step must be completed to ensure your product gives you long service

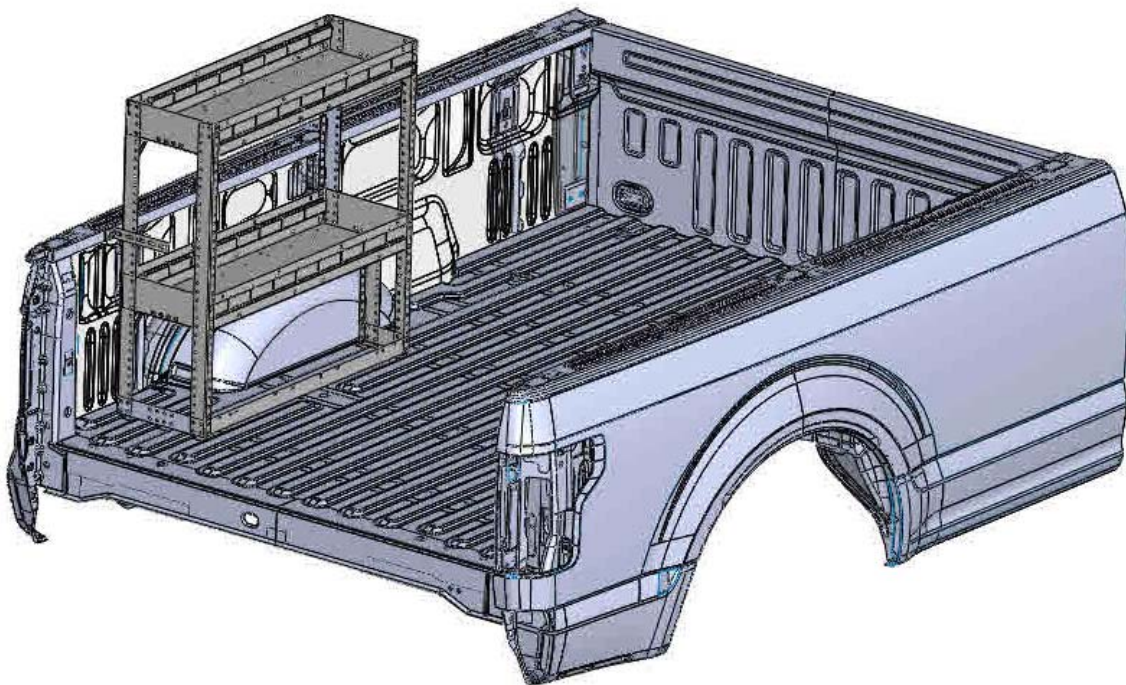

ATTACHEMENT FOR ALUMINUM F150 TRUCK BODIES.

- PRECAUTIONS -





 **CAUTION** 
**THE USE OF AIR IMPACT TOOLS CAN
OVER-TORQUE FASTENERS AND
CAUSE FASTENER FAILURE!**



 **CAUTION** 
**ALL INSTALLATION HOLES SHOULD BE SEALED
WITH SILICON OR BUTYL SEALANT TO PREVENT
EXHAUST FUMES FROM ENTERING THE VEHICLE!**



 **DANGER** 
**INSPECT FOR FUEL TANK, FUEL LINES, BRAKE LINES, HIGH
VOLTAGE BATTERIES AND ELECTRICAL LINES PRIOR TO
DRILLING TO AVOID DAMAGING CRITICAL VEHICLE SYSTEMS
OR INJURY TO INSTALLER DURING INSTALLATION PROCESS!**



 **CAUTION** 
**TO AVOID DAMAGING THE VEHICLE ALWAYS
USE DRILL STOPS WHEN DRILLING ANY IN-
STALLATION HOLES!**



- IMPORTANT WARRANTY REQUIREMENTS -

1. SUBSTITUTING ADRIAN STEEL SPECIFIED FASTENERS FOR ASSEMBLY AND/OR INSTALLATION WILL VOID YOUR PRODUCT WARRANTY.
2. ALL HOLES DRILLED INTO VEHICLE SHOULD HAVE THE RAW METAL EDGES SEALED WITH A SELF-ETCHING PRIMER TO RESIST CORROSION AND POTENTIAL FASTENER POINT FAILURE.
3. ALL FASTENERS USED IN THE INSTALLATION OF THIS PRODUCT SHOULD BE TIGHTENED TO THE TORQUE(S) SPECIFIED IN THESE INSTRUCTIONS.
4. THESE INSTRUCTIONS SHOULD BE KEPT WITH THE VEHICLE.

THE BASIC TOOLS NEEDED FOR MOST INSTALLATIONS



DRILL



DRILL BIT WITH
STOP



RATCHET, SOCKETS
AND/OR WRENCHES



SCREWDRIVERS



MEASURING TAPE

ADDITIONAL TOOLS MAY BE NEEDED FOR THIS INSTALLATION AND THEY WILL BE IDENTIFIED IN THE STEPS THAT FOLLOW.

If your vehicle contains carpet or a rubber floor mat you will need to prepare the mounting location. Position the product to be installed into the vehicle and once you are satisfied with the mounting locations, mark the mounting locations. Using a 1-3/16" diameter carpet cutter (P/N: 31183-0). Select the appropriate floor spacers as shown in the illustration. Set those aside for use later into the installation process. Using the correct drill bit size for the selected plusnut, drill the mounting holes in the vehicle sheet metal to prepare for installing the plusnuts. If you are thru-bolting at any of the locations simply drill a hole that is 1/16" larger than the bolt size(s) for those locations. Once you have drilled the holes into the vehicle, the raw metal edges should be sealed using a self-etching primer to resist corrosion and potential fastener point failure.

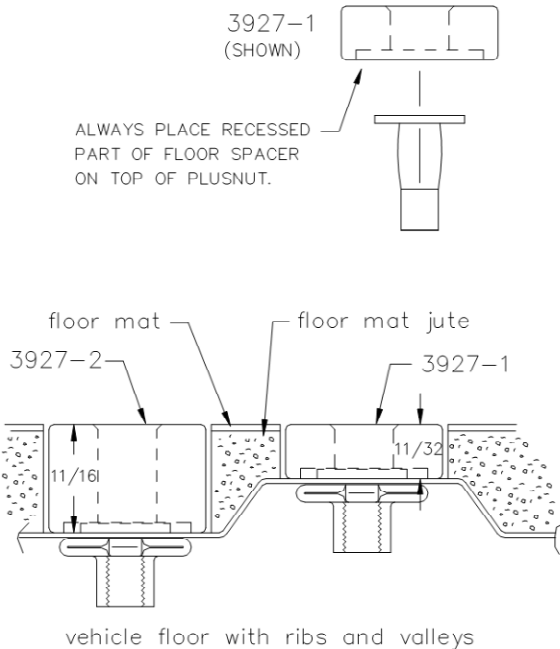

A PLUSNUT (RIVNUT) SETTING TOOL IS REQUIRED FOR PLUSNUT (RIVNUT) INSTALLATION AND IS SUPPLIED WITH THIS KIT. OR USE AN AIR POWERED PLUSNUT SETTING GUN.

1/4-20UNC Plusnut (FAS0052) Use 3/8" dia. drill w/stop
 FAS0080 SCREW, HXHD, 1/4-20UNCx2.00", G8
 FAS0067 WASHER, FLAT, 1/4"ID
 22200-0 PLUSNUT TOOL

5/16-18UNC Plusnut (FAS0091) Use 1/2" dia. drill w/stop
 FAS0095 SCREW, HXHD, 5/16-18UNCx2.00", G8
 FAS0086 WASHER, FLAT, 5/16"ID
 22200-0 PLUSNUT TOOL

Place barrel of the plusnut body in sheet metal thru hole until flange is flush with sheet metal. Using a 9/16" combination wrench of plusnut tool body and a second hand wrench, ratchet, or air tool, rotate the hex bolt head CW to draw plus nut flanges up (set the plusnut).

**Step 1: Apply touch-up to drilled holes.
Recommended anti corrosion coatings. All holes must have corrosion sealer applied.**



MOTORCRAFT PM13-A



NOX-RUST 7703-W



ANY ZINC RICH PRIMER

Generic installation process.
As recommended by Ford Co.
See next page with Adrian Steel Part numbers.

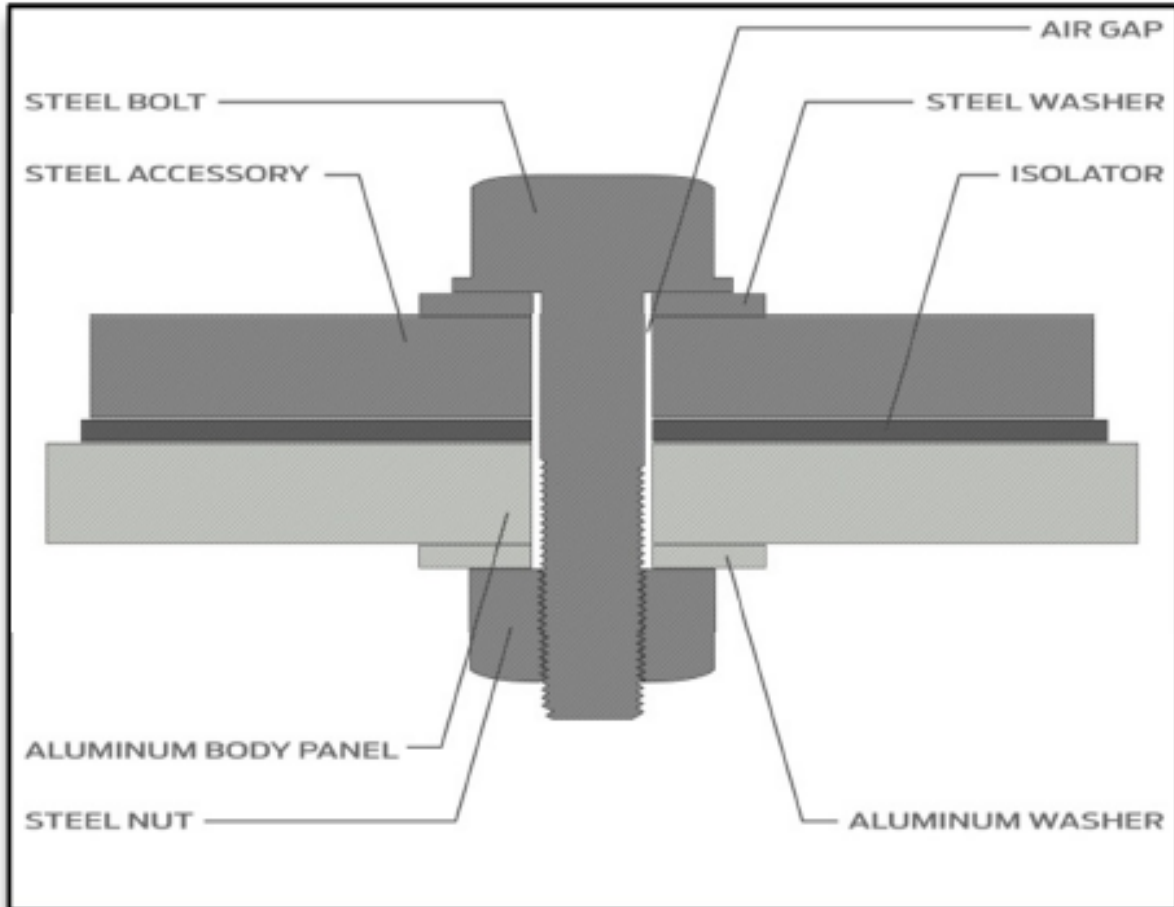

Mounting Brackets

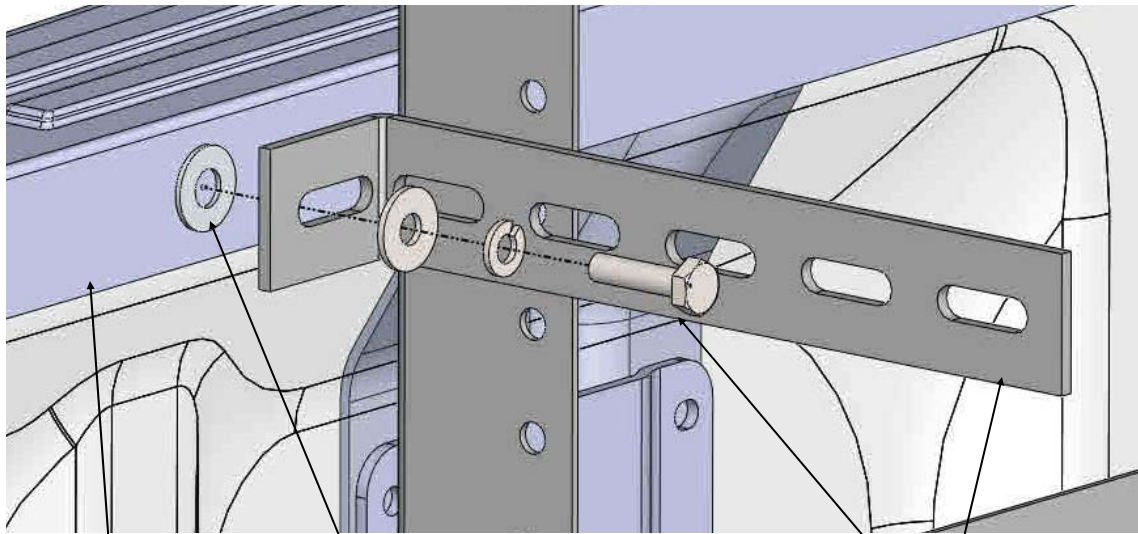

BED RAILS

FAS0164
(5/16—ALUM WASHER)

FASTENERS AND MOUNTING BRACKETS IN KD UNIT

INSIDE BED RAIL

FAS0164
(5/16—ALUM WASHER)

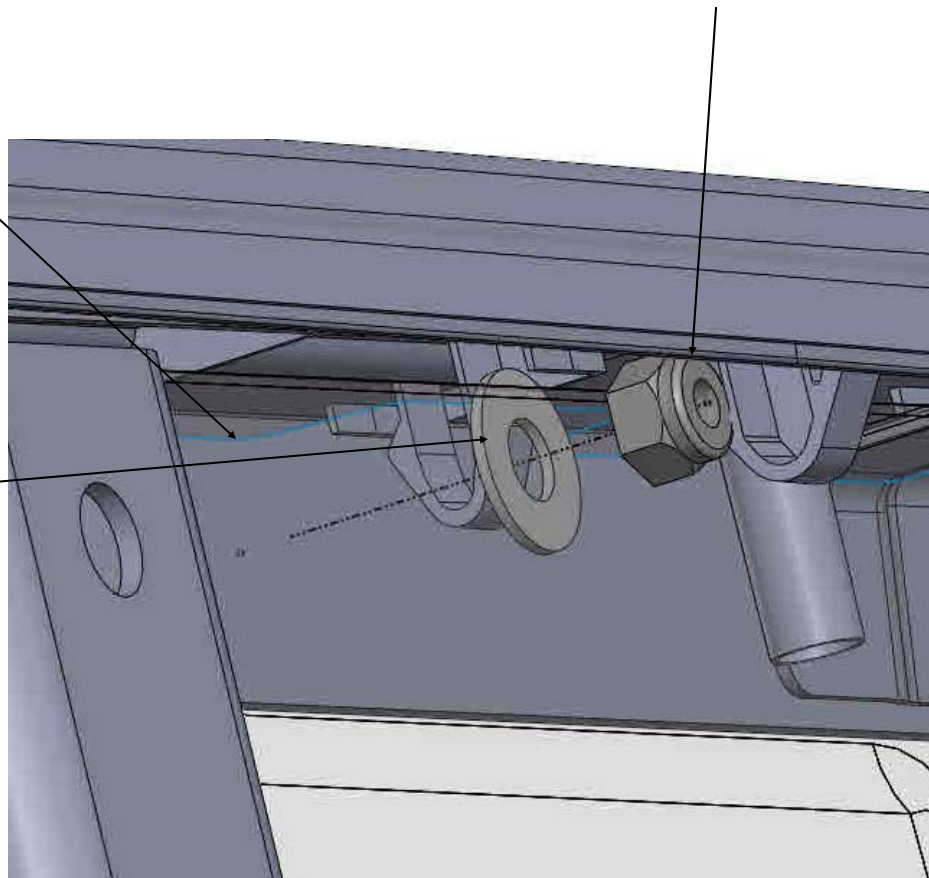

KD UNITS

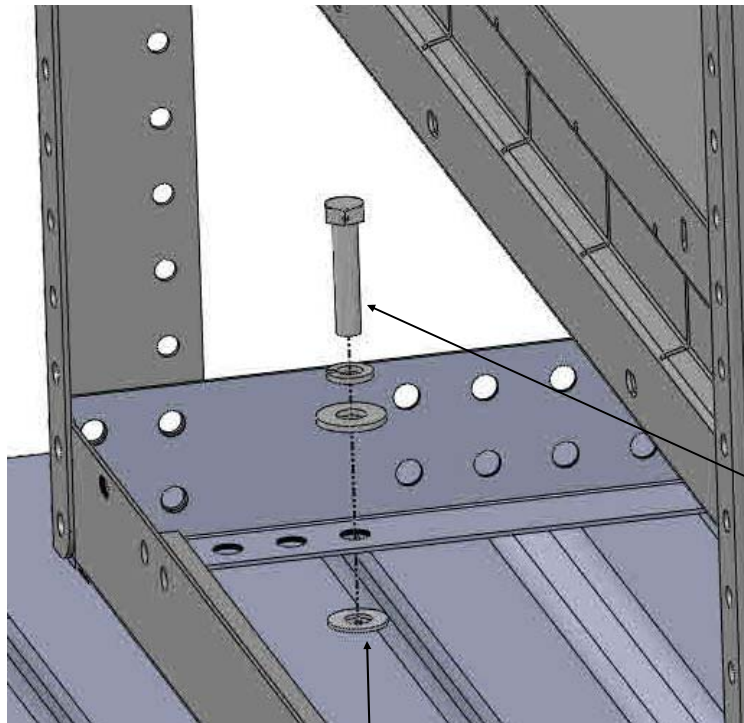

FASTENERS INCLUDED
IN KD UNIT. IF SPACER
IS REQUIRED, PLACE
WASHER UNDER SPAC-
ER

FAS0164 (5/16—
ALUM WASHER)

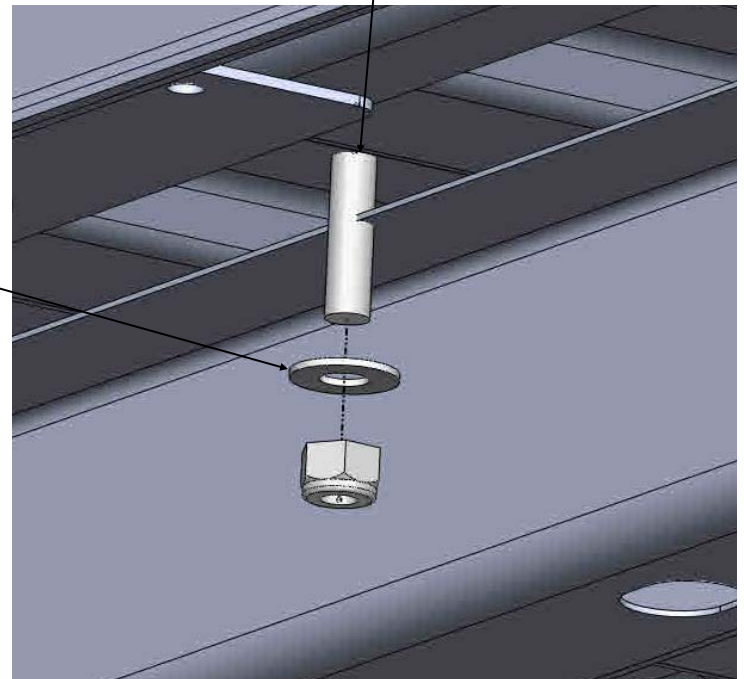

**DOUBLE CHECK ALL FASTENERS LOCATIONS TO BE SURE THAT ALL
FASTENERS ARE TIGHTENED TO SPECIFICATIONS.
YOUR INSTALLATION IS NOW COMPLETE!
STOW THIS COPY IN THE VEHICLE FOR FUTURE REFERENCES!**