

## Single Ladder Stop Kit

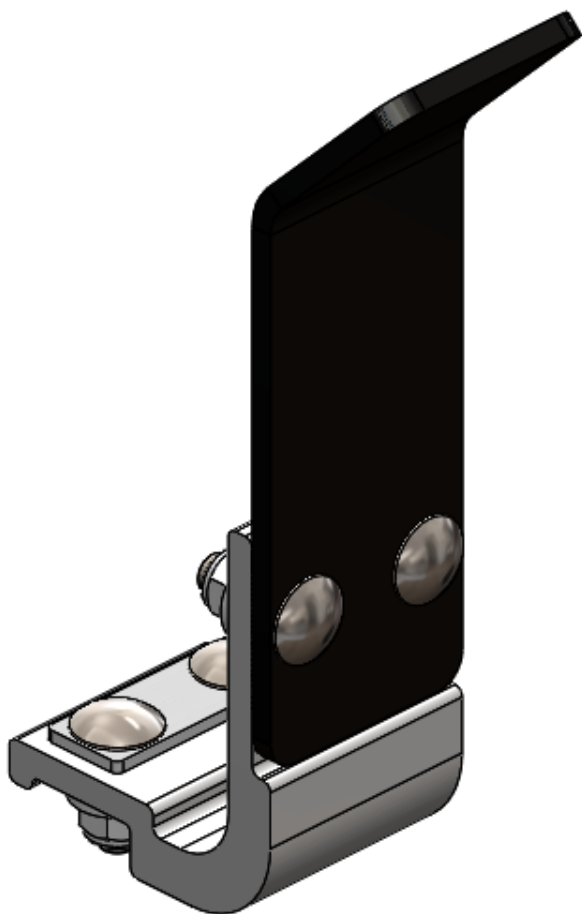

PRODUCT WEIGHT  
**1.3 LBS**

WIDTH x DEPTH x HEIGHT  
**2" x 1.8" x 6.3"**

CAPACITY  
**N/A**

COLOR  
**BLACK**

CATALOG NUMBER  
**ULSKB**

### PRODUCT FEATURES

Aluminum ladder stop kit with plastisol coating for PROFILE™ HD Utility and combo ladder racks. Works on all vehicle platforms. Works with all upright kits, conduit kits, and rear rollers.

Utility style ladder racks are not recommended for medium and high roof vehicles!

Please refer to OEM specific mounting kit and rail kit for additional information on compatible accessories.

**SEE PAGE 2 FOR APPLICATION NOTES AND ACCESSORIES, OTHER PRODUCTS THAT WORK WITH THIS UNIT.**



**CATALOG NUMBER ULSKB**

**PRODUCT APPLICATION**

**This product is for PROFILE™ HD Utility and combo ladder racks. Works on all vehicle platforms. Utility style ladder racks are not recommended for medium or high roof vehicles!**

**ACCESSORIES THAT WILL WORK WITH THIS PRODUCT**

<b>CATALOG NUMBER</b>	<b>DESCRIPTION</b>
<b>2BARW</b>	<b>2-Crossbar Kit, 68”, White, Full Size Van</b>
<b>2BARCW</b>	<b>2-Crossbar Kit, 58”, White, Minivan</b>
<b>1BARW</b>	<b>Single Crossbar Kit, 68”, White, Full Size Van</b>
<b>1BARCW</b>	<b>Single Crossbar Kit, 58”, White, Minivan</b>

<i>INSTR. NUMBER</i> : <b>64337</b>	<i>PG:</i> <b>1</b>	<i>REV:</i> <b>C</b>	<i>ITEM NO.</i>	<i>PART NUMBER</i>	<i>DESCRIPTION</i>	<i>QTY.</i>
			1	63854-W	UTILITY,CONNECTING BRKT,W	1
<i>PART NUMBER</i> : <b>ULSKB</b>			2	63850-B	UTILITY, LADDER STOP, B	1
<i>PART DESC.</i> : UTILITY, LADDER STOP KIT						

**NOTE: THIS INSTRUCTION IS INTENDED TO BE USED WITH THE #BARW OR #BARCW UTILITY RACKS.**

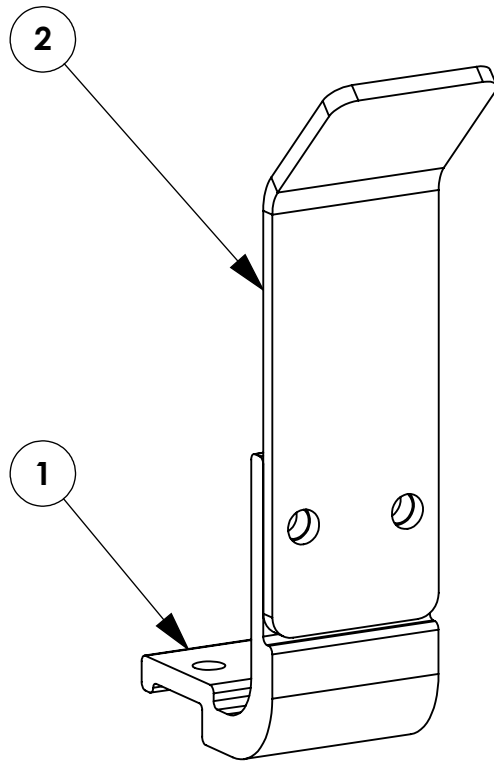

**GET TO KNOW THE VEHICLE** - AT THE BEGINNING OF ANY INSTALLATION, CHECK THE LOCATION OF THE FUEL TANK, FUEL LINES, BRAKE LINES, HIGH VOLTAGE BATTERIES AND WIRING HARNESES TO AVOID INJURY OR PROPERTY DAMAGE FROM TOOL CONTACT.

**SEAL ALL EXTERIOR HOLES** - ALL INSTALLATION HOLES SHOULD BE SEALED WITH BUTYL TAPE OR SILICON TO PREVENT WATER AND EXHAUST GASES FROM ENTERING THE VEHICLE.

**CONTROL DRILL DEPTH** - TO AVOID DAMAGE TO THE VEHICLE, USE A DRILL STOP OR CLEARED STEP BIT WHEN DRILLING INSTALLATION HOLES.

**ALWAYS ADD PRIMER** - WHEN ADDING INSTALLATION HOLES BE SURE TO USE A SELF-ETCHING PRIMER TO PREVENT CORROSION, FASTENER FAILURE AND INJURY.

**MOUNTING POINTS MUST HAVE METAL-TO-METAL CONTACT** - USE PROVIDED MOUNTING SPACERS TO ACCOMMODATE FOR VEHICLE FEATURES, CARPET OR SUBFLOORS.

**PROVIDE CLEARANCE FOR SPACERS** - IF THE INSTALLATION VEHICLE CONTAINS A CARPET OR SUBFLOOR, USE A 1-3/16" DIAMETER CARPET CUTTER (P/N: 31183-0) AT ALL MOUNTING LOCATIONS TO OPEN UP ROOM FOR SPACERS.

**CHECK SPACER ORIENTATION** - BE SURE THAT THE INDENT IN THE SPACER COVERS THE PLUSNUT HEAD; THIS ENSURES THE MOST METAL-TO-METAL CONTACT AND REDUCES VIBRATION.

**PLUSNUT INSTALLATION** - A PLUSNUT GUN IS RECOMMENDED FOR PLUSNUT INSTALLATION FOR ITS PRODUCTION SPEED. HOWEVER, A PLUSNUT SETTING TOOL CAN ALSO BE USED (P/N: 22200-0).

**THRU-BOLT CLEARANCE** - WHEN USING A THRU-BOLT AT ANY MOUNTING LOCATION, BE SURE THAT YOUR HOLE HAS 1/16" CLEARANCE.

***FASTENERS USED***

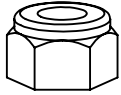

**FAS0248  
5/16-18 SS  
NLK HEX NUT  
QTY: 4**

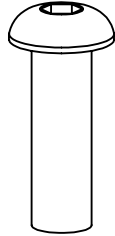

**FAS0813  
5/16-18X1.0 SS  
BHCS SCREW  
QTY: 4**



**FAS0552  
5/16 SS  
FLAT WASHER  
QTY: 4**

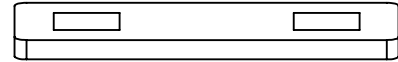

**63934  
UTILITY,  
BOLT PLATE  
QTY: 1**

**BEGIN ASSEMBLY**  
**STEP 1 - ASSEMBLE BRACKET**

(2)FAS0813, (4)FAS0552,  
(2)FAS0248  
1/2 SOCKET  
3/16 HEX DRIVE

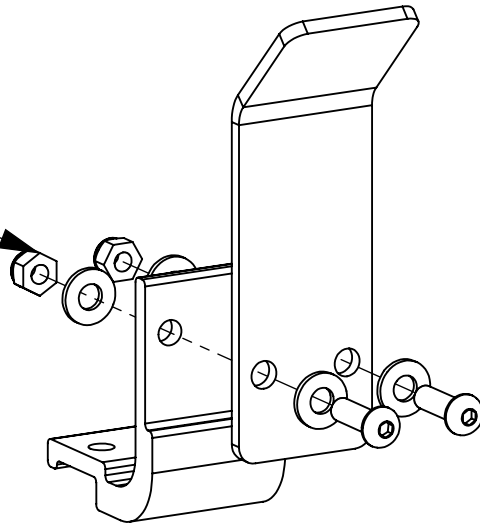

**BEGIN INSTALLATION**  
**STEP 2 - INSTALL BRACKET**

(2)FAS0398, 63934  
(2)FAS0552, (2)FAS0248  
1/2 SOCKET

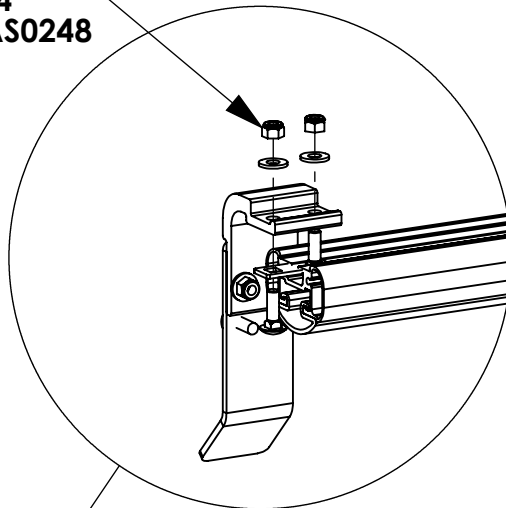

**MAKE SURE THE LADDER STOP IS BETWEEN THE CARRIAGE BOLT AND PLATE ASSEMBLY FOR EACH MOUNTING BRACKET.**

**ADJUST LADDER STOP TO BE IN THE CENTER OF CARGO**

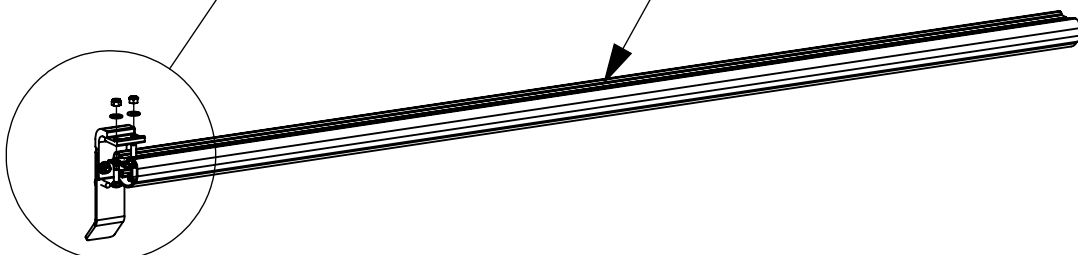



## 2-Crossbar Kit, 58", White, Minivan



PRODUCT WEIGHT  
**16.1 LBS**

CROSSBOW LENGTH X  
HEIGHT

**59" x 2"**

CAPACITY

**REFER TO OEM'S  
RECOMMENDED LOAD  
RATING**

COLOR

**WHITE**

CATALOG NUMBER

**2BARCW**

### PRODUCT FEATURES

Aluminum base 2-crossbow kit for PROFILE™ HD Utility, grip lock, drop down, or combo ladder racks. Works with all compact van platforms for each respective wheelbase and Ford Transit Ship Thru. Works with and without OEM specific rail kit and generic mounting bracket kits.

Optional uprights and conduit kits available.

Please refer to OEM specific mounting kit or rail kit for additional information on compatible accessories.

# INSTALLATION GUIDE FOR PROFILE™ SERIES LADDER RACKS

INSTRUCTION #:  
**68895**

REV:  
**B**

THIS INSTRUCTION PROVIDES A GENERAL GUIDE OF INSTALLATION SEQUENCE FOR ALL PROFILE™ SERIES LADDER RACKS. PLEASE ENSURE ALL ACCESSORIES ARE INSTALLED PER TYPE OF RACK BEFORE PROCEEDING TO NEXT PAGE.

REFERENCE THIS INSTRUCTION THROUGHOUT THE ENTIRETY OF YOUR INSTALL TO PREVENT ACCESSORIES BEING INSTALLED INCORRECTLY/OUT OF SEQUENCE!

STEPS 21 - 81 ON PAGE 3 IS THE RECOMMENDED ASSEMBLY SEQUENCE FOR A FULL TABLE ASSEMBLY BEFORE INSTALLING ON THE ROOF OF THE VEHICLE.

STEPS 2R - 8R ON PAGE 4 IS AN ALTERNATE ASSEMBLY SEQUENCE TO INSTALL THE RACK ON THE VEHICLE ROOF AS IT IS BUILT.

PLEASE SELECT THE ASSEMBLY SEQUENCE THAT BEST WORKS FOR YOU!

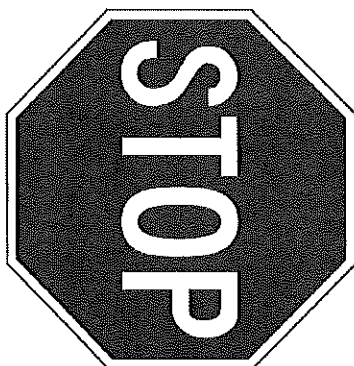

## ASSEMBLY STEPS:

**STEP 1A. SUB-ASSEMBLE EACH CROSSBOW WITH DESIRED ACCESSORIES FOR SECTIONS A.1 & A.2.**

*INSTRUCTIONS FOR EACH KIT CAN BE FOUND IN THEIR RESPECTIVE CARTON!*

TOP OF CROSSBOW \*IMAGE NOT TO SCALE!

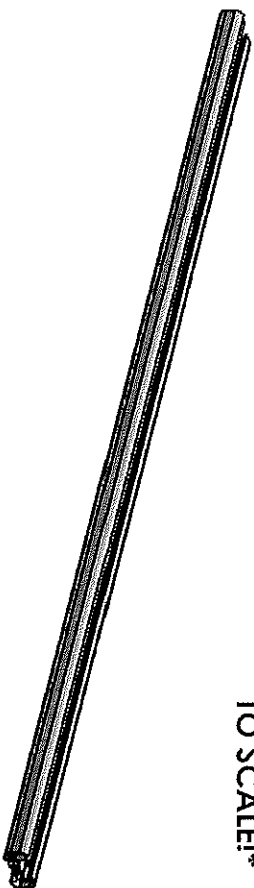

BOTTOM OF CROSSBOW

**TABLE 1**

### TOP OF CROSSBOW

COMPONENTS TO INSTALL

HD UTILITY

- CONDUIT KIT OR BEACON

Grip-Lock

- CONDUIT KIT OR BEACON

ProLift

- CONDUIT KIT OR BEACON

### BOTTOM OF CROSSBOW

COMPONENTS TO INSTALL

HD UTILITY

- LADDER STOP, STROBE BRACKET, AND/OR REAR ROLLER

Grip-Lock

- Grip-Lock SUB-ASSEMBLY

ProLift

- DAMPER BRACKET

A.2

A.1



**STEP 1B. SUB-ASSEMBLE EACH CROSSBOW WITH DESIRED ACCESSORIES FOR SECTIONS B.1 & B.2. INSTRUCTIONS FOR EACH KIT CAN BE FOUND IN THEIR RESPECTIVE CARTON!**

**TOP OF CROSSBOW**

**\*IMAGE NOT TO SCALE!\***

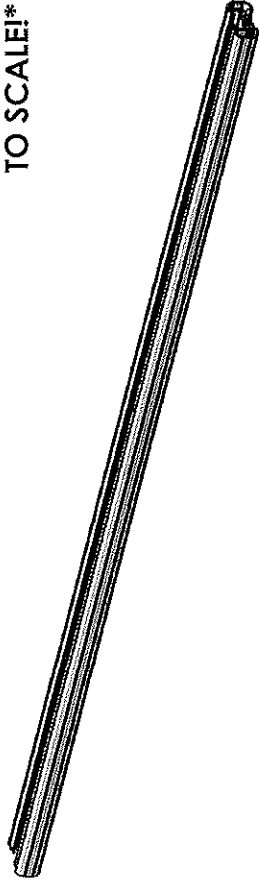

**BOTTOM OF CROSSBOW**

**TABLE 2**

TOP OF CROSSBOW	
COMPONENTS TO INSTALL	
HD UTILITY	- WEAR STRIP (MODIFY IF NECESSARY, TABLE 3)
Grip-Lock	- WEAR STRIP (MODIFY IF NECESSARY, TABLE 3)
ProLift	- INNER STOP POST
BOTTOM OF CROSSBOW	
COMPONENTS TO INSTALL	
HD UTILITY	- MOUNTING BRACKETS
Grip-Lock	- MOUNTING BRACKETS
ProLift	- MOUNTING BRACKETS

**ALTER WEAR STRIP AND INSTALL ON CROSSBOW (IF APPLICABLE)! REFERENCE TABLE 3 BELOW FOR WEAR STRIP ALTERATION INSTRUCTIONS!**

**TABLE 3**

ADDED ACCESSORIES	ALTERATION FOR WEAR STRIP
4" UPRIGHT***	REMOVE 2" FROM END OF WEAR STRIP
4" PVC CONDUIT KIT	REMOVE 7.25" FROM CENTER OF WEAR STRIP
6" PVC CONDUIT KIT	REMOVE 9.50" FROM CENTER OF WEAR STRIP
ALUMINUM BOX CONDUIT KIT	REMOVE 13.25" FROM CENTER OF WEAR STRIP
BEACON	REMOVE 4" FROM CENTER OF WEAR STRIP
ProLift (SINGLE SIDE)	CUT WEAR STRIP IN HALF, DO NOT INSTALL ON ProLift SIDE
ProLift (DUAL SIDE)	DO NOT INSTALL WEAR STRIP

**SLIDE WEAR STRIP INTO RAIL AND CENTER (1 PER CROSSBOW)**

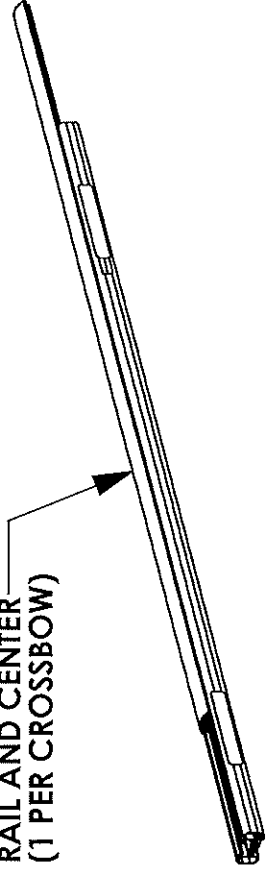

**STEP 1C SUB-ASSEMBLE EACH CROSSBOW WITH DESIRED ACCESSORIES FOR SECTIONS C.1 & C.2**

TOP OF CROSSBOW  
\*IMAGE NOT TO SCALE!\*

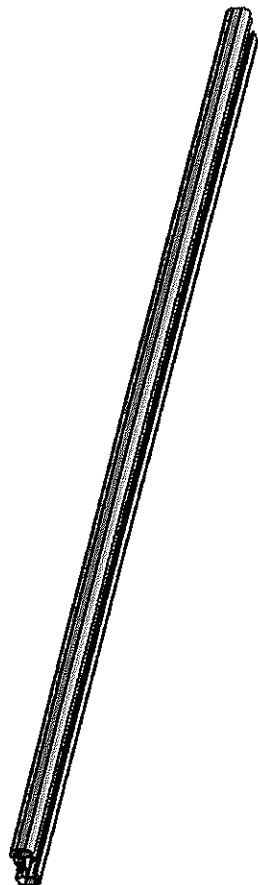

BOTTOM OF CROSSBOW

**TABLE 4**

TOP OF CROSSBOW		BOTTOM OF CROSSBOW	
COMPONENTS TO INSTALL		COMPONENTS TO INSTALL	
	HD UTILITY		- 4" UPRIGHT
C.1	Grip-Lock		- N/A
	Prolift		- SLIDES FOR BASE EXTRUSION
BOTTOM OF CROSSBOW			
COMPONENTS TO INSTALL			
	HD UTILITY		- UPRIGHTS (6", 9", RATCHET)
C.2	Grip-Lock		- STROBES
	Prolift		- STROBES

**ASSEMBLY STEPS (FULL BENCH ASSEMBLY):**

- 2T. ADD DRIVELINES (IF INSTALLING Prolift)
- 3T. ADD HANDLES (IF INSTALLING Grip-Lock OR Prolift) AND DAMPERS (IF INSTALLING Prolift)
- 4T. ADD OUTER SUPPORT BARS (IF INSTALLING Grip-Lock OR Prolift)
- 5T. ADD STEP LADDER KIT (Grip-Lock OR Prolift ONLY)

6T. ASSEMBLE ENDS CAPS TO CROSSBOW

USED FOR HD UTILITY & Grip-Lock RACKS

LOCATED IN CROSSBOW KIT

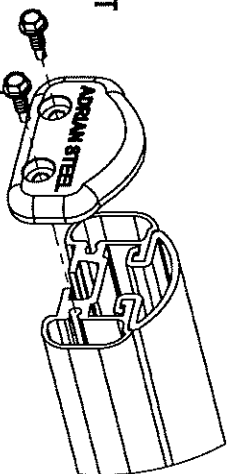

FULLY TIGHTEN  
(2) FAS0473, 63851  
(2 PLACES PER END CAP)  
5/16" SOCKET

USED FOR Prolift RACKS  
LOCATED IN Prolift Kit

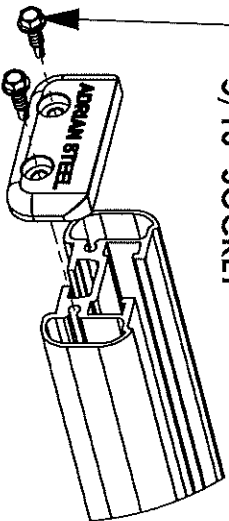

7T. INSTALL ROOF RAIL KIT ON VEHICLE ROOF OR BOTTOM MOUNTING BRACKETS

(ROOF RAIL KIT REQUIRED FOR Grip-Lock & Prolift OPTIONAL FOR HD UTILITY, NOT NEEDED FOR GM LADDER RACKS)

8T. MOUNT CROSSBOW SUB-ASSEMBLIES FROM STEP 1 TO VEHICLE/MOUNTING BRACKET, OR ROOF RAIL (LOOSE INSTALL)

**ALTERNATE ASSEMBLY METHOD!**  
**(ASSEMBLE ON VEHICLE ROOF):**

- 2R. INSTALL ROOF RAIL KIT ON VEHICLE ROOF OR BOTTOM MOUNTING BRACKETS  
(ROOF RAIL KIT REQUIRED FOR Grip-Lock & ProLift, OPTIONAL FOR HD UTILITY, NOT NEEDED FOR GM LADDER RACKS)
- 3R. MOUNT CROSSBOW SUB-ASSEMBLIES FROM STEP 1 TO VEHICLE/MOUNTING BRACKET, OR ROOF RAIL (LOOSE INSTALL)
- 4R. ADD DRIVELINES (IF INSTALLING ProLift)
- 5R. ADD HANDLES (IF INSTALLING Grip-Lock OR ProLift) AND DAMPERS (IF INSTALLING ProLift)
- 6R. ADD OUTER SUPPORT BARS (IF INSTALLING Grip-Lock OR ProLift)
- 7R. ADD STEP LADDER KIT (Grip-Lock OR ProLift ONLY!)

8R. ASSEMBLE END CAPS TO CROSSBOW

USED FOR HD UTILITY & Grip-Lock RACKS

LOCATED IN CROSSBOW KIT

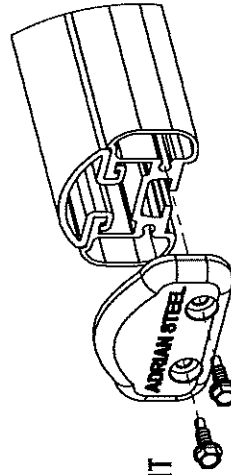

FULLY TIGHTEN  
(2) FAS0473, 63851  
(2 PLACES PER END CAP)  
5/16" SOCKET

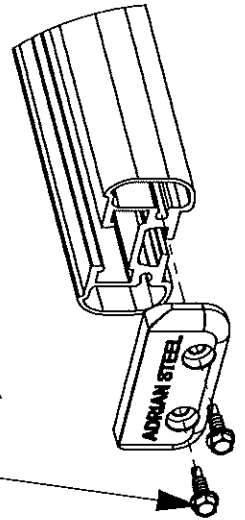

USED FOR ProLift RACKS  
LOCATED IN ProLift Kit



## 6" Upright Kit, 4-Pack, Black

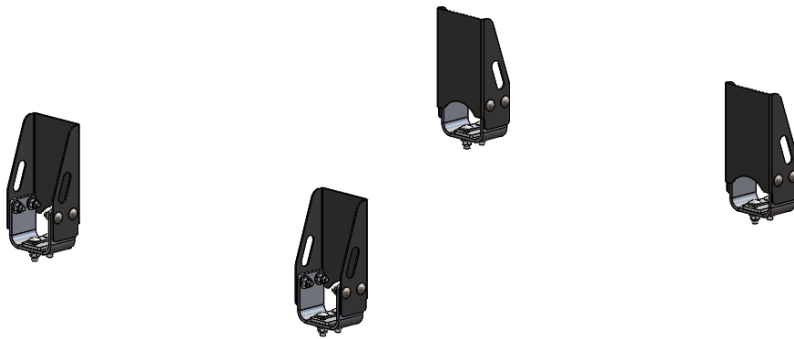

PRODUCT WEIGHT  
**9.3 LBS**

WIDTH x DEPTH x HEIGHT

**3.8" x 2.3" x 6"**

CAPACITY

**N/A**

COLOR

**BLACK**

CATALOG NUMBER

**6UPK4B**

### PRODUCT FEATURES

Galvanized steel 6" uprights fully plastisol coated for PROFILE™ HD Utility and combo ladder racks. Works on all vehicle platforms. Works with all conduit kits and rear rollers.

Utility style ladder racks are not recommended for medium and high roof vehicles!

Please refer to OEM specific mounting kit and rail kit for additional information on compatible accessories.

**SEE PAGE 2 FOR APPLICATION NOTES AND ACCESSORIES, OTHER PRODUCTS THAT WORK WITH THIS UNIT.**

**PAGE 1 of 2**

The information contained in this document is the sole property of ADRIAN STEEL COMPANY. ADRIAN STEEL COMPANY retains the right to modify and/or change the product of its design at any time without prior notification.



**CATALOG NUMBER 6UPK4B**

**PRODUCT APPLICATION**

**This product is for PROFILE™ HD Utility and combo ladder racks. Works on all vehicle platforms. Utility style ladder racks are not recommended for medium or high roof vehicles!**

**ACCESSORIES THAT WILL WORK WITH THIS PRODUCT**

<b>CATALOG NUMBER</b>	<b>DESCRIPTION</b>
<b>2BARW</b>	<b>2-Crossbar Kit, 68”, White, Full Size Van</b>
<b>2BARCW</b>	<b>2-Crossbar Kit, 58”, White, Minivan</b>
<b>1BARW</b>	<b>Single Crossbar Kit, 68”, White, Full Size Van</b>
<b>1BARCW</b>	<b>Single Crossbar Kit, 58”, White, Minivan</b>

INSTR. NUMBER : <b>65319</b>		PG: <b>1</b>	REV: <b>C</b>	ITEM NO.	PART NUMBER	DESCRIPTION	QTY.
PART NUMBER • <b>6UPK2B</b> PART NUMBER • <b>9UPK2B</b>				1	65120-W	UTILITY,UPR MOUNT BRKT,W	2
				2	63848-B	UTILITY, UPRIGHT, 6", B	2
PART • UTILITY,6" UPRIGHT KIT,2B DESC. • UTILITY,9" UPRIGHT KIT,2B				3*	65120-W	UTILITY,UPR MOUNT BRKT,W	2
				4*	64060-B	UTILITY, UPRIGHT, 9", B	2

**NOTE: THIS INSTRUCTION IS VALID FOR THE FOLLOWING UPRIGHT KITS:**

**6UPK2B (SHOWN)**

**6UPK4B**

**9UPK2B**

**9UPK4B**

**ITEMS NOTED (#\*) ARE PART OF 9UPK2B**

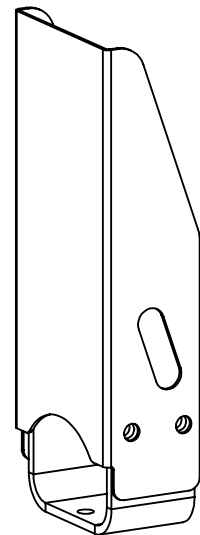
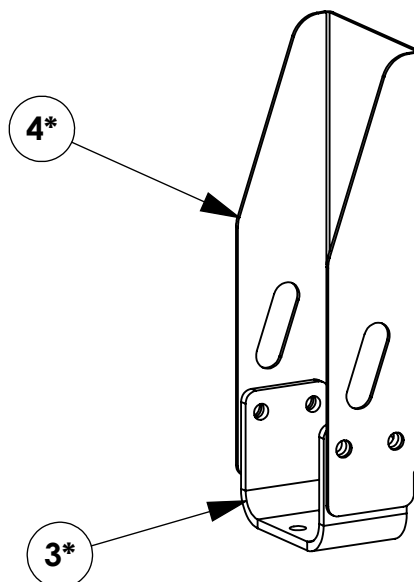
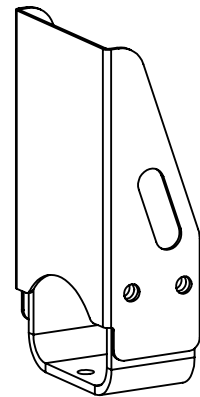
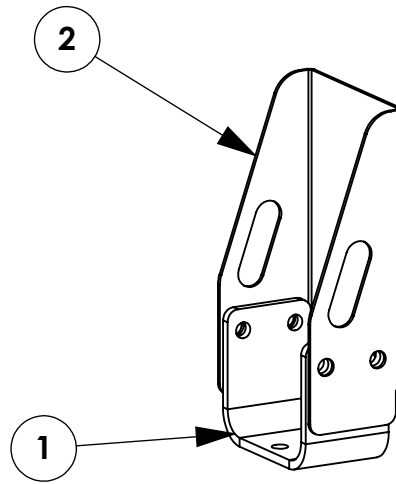

**GET TO KNOW THE VEHICLE** - AT THE BEGINNING OF ANY INSTALLATION, CHECK THE LOCATION OF THE FUEL TANK, FUEL LINES, BRAKE LINES, HIGH VOLTAGE BATTERIES AND WIRING HARNESSSES TO AVOID INJURY OR PROPERTY DAMAGE FROM TOOL CONTACT.

**SEAL ALL EXTERIOR HOLES** - ALL INSTALLATION HOLES SHOULD BE SEALED WITH BUTYL TAPE OR SILICON TO PREVENT WATER AND EXHAUST GASES FROM ENTERING THE VEHICLE.

**CONTROL DRILL DEPTH** - TO AVOID DAMAGE TO THE VEHICLE, USE A DRILL STOP OR CLEARED STEP BIT WHEN DRILLING INSTALLATION HOLES.

**ALWAYS ADD PRIMER** - WHEN ADDING INSTALLATION HOLES BE SURE TO USE A SELF-ETCHING PRIMER TO PREVENT CORROSION, FASTENER FAILURE AND INJURY.

**MOUNTING POINTS MUST HAVE METAL-TO-METAL CONTACT** - USE PROVIDED MOUNTING SPACERS TO ACCOMMODATE FOR VEHICLE FEATURES, CARPET OR SUBFLOORS.

**PROVIDE CLEARANCE FOR SPACERS** - IF THE INSTALLATION VEHICLE CONTAINS A CARPET OR SUBFLOOR, USE A 1-3/16" DIAMETER CARPET CUTTER (P/N: 31183-0) AT ALL MOUNTING LOCATIONS TO OPEN UP ROOM FOR SPACERS.

**CHECK SPACER ORIENTATION** - BE SURE THAT THE INDENT IN THE SPACER COVERS THE PLUSNUT HEAD; THIS ENSURES THE MOST METAL-TO-METAL CONTACT AND REDUCES VIBRATION.

**PLUSNUT INSTALLATION** - A PLUSNUT GUN IS RECOMMENDED FOR PLUSNUT INSTALLATION FOR ITS PRODUCTION SPEED. HOWEVER, A PLUSNUT SETTING TOOL CAN ALSO BE USED (P/N: 22200-0).

**THRU-BOLT CLEARANCE** - WHEN USING A THRU-BOLT AT ANY MOUNTING LOCATION, BE SURE THAT YOUR HOLE HAS 1/16" CLEARANCE.

**FASTENERS USED**

**QUANTITIES ARE LISTED FOR 6UPK2B / 9UPK2B.  
QUANTITIES WILL VARY BASED ON NUMBER OF UPRIGHTS**

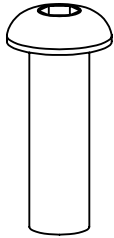

FAS0813  
5/16-18x1.0 SS  
BHCS SCREW  
QTY: 8

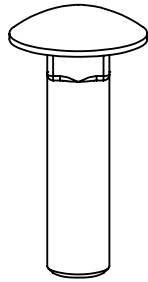

FAS0812  
5/16-18x1.25 SS  
CRG BOLT  
QTY: 4

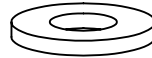

FAS0552  
5/16 SS  
FLAT WASHER  
QTY: 12

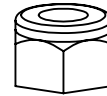

FAS0248  
5/16-18 SS  
NLK HEX NUT  
QTY: 12

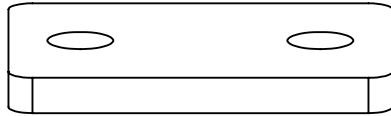

63933  
UTILITY,  
SPACER  
QTY: 2

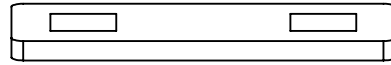

63934  
UTILITY,  
BOLT PLATE  
QTY: 2



**BEGIN ASSEMBLY**  
**STEP 1 - ASSEMBLE UPRIGHTS**

FAS0813, (2) FAS0552,  
AND FAS0248  
(4 PLACES PER UPRIGHT)  
3/16 HEX DRIVE  
1/2 SOCKET

DRILL HOLES IN UPRIGHT  
WITH 11/32" DRILL BIT  
BEFORE ASSEMBLING!  
(4 PLACES PER UPRIGHT)

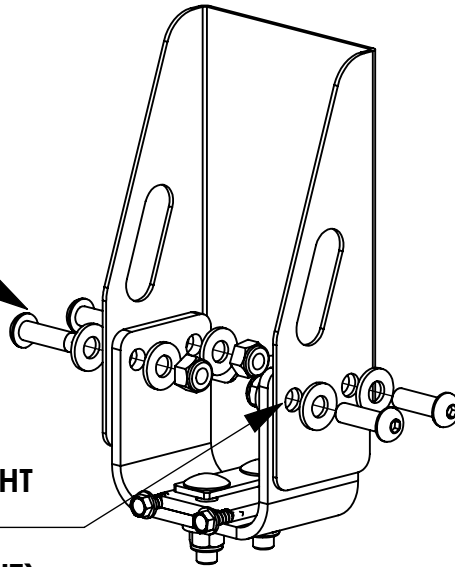

**BEGIN INSTALLATION**  
**STEP 2 - INSTALL UPRIGHTS**

(2) FAS0812, (2) FAS0552,  
63933, 63934, & (2) FAS0248  
(PER UPRIGHT)  
1/2 SOCKET

ALIGN UPRIGHT WITH  
EDGE OF CROSSBOW

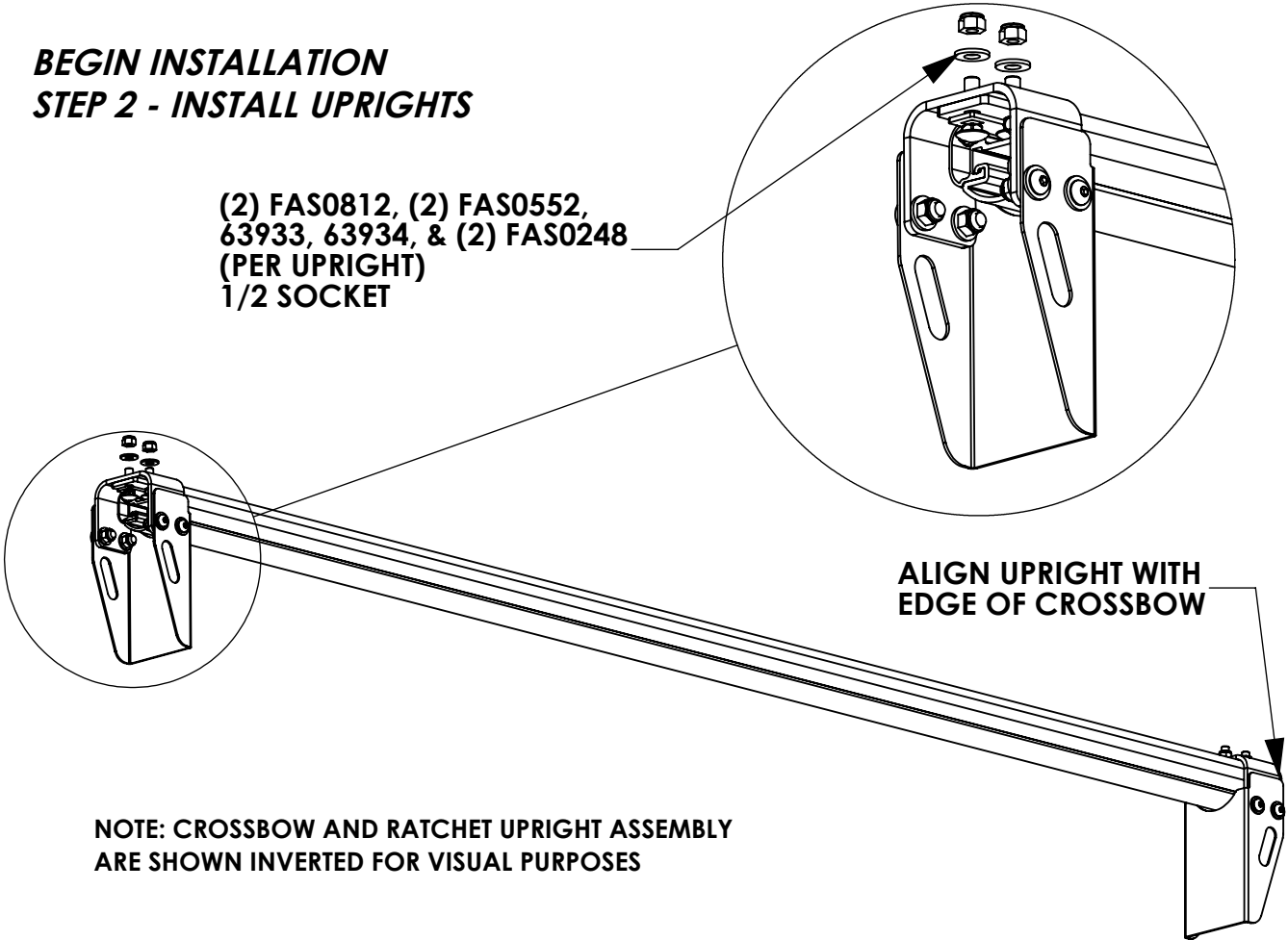

NOTE: CROSSBOW AND RATCHET UPRIGHT ASSEMBLY  
ARE SHOWN INVERTED FOR VISUAL PURPOSES

CONTINUE WITH INSTALLATION WITH THE MOUNTING KIT INSTRUCTIONS