



ADRIAN STEEL

Carpa Management Solutions for Commercial Vehicles

CENTER BOW ADD-ON KIT, 1BTCGL

PRODUCT WEIGHT

5 Lbs

WIDTH x DEPTH x HEIGHT

55" x 2" x 4"

CAPACITY

N/A

COLOR

**ALUMINUM AND
BLACK**

CATALOG NUMBER

1BTCGL

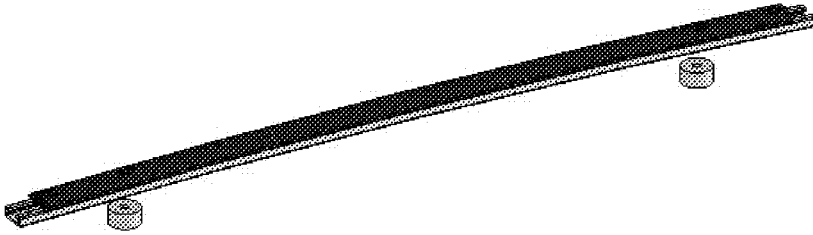

PRODUCT FEATURES

**CENTER BOW ADD-ON KIT FOR ADDED SUPPORT OF LOAD AND/OR
CARRYING SHORT STEP LADDERS.**

PRODUCT APPLICATION

**THIS PRODUCT IS DESIGNED FOR USE WITH THE FORD TRANSIT
CONNECT GRIP-LOCK LADDER RACKS, 61-TC AND 63-TC.**

P.N.: 37571-0
ISSUE: D
CHK.BY:
REV.BY: RHS
DWG.BY: RHS
DATE: 06/13/12
ECN- 14843

3rd Bow Kit for Grip-Lock Rack Ford Transit Connect

1BTCGL

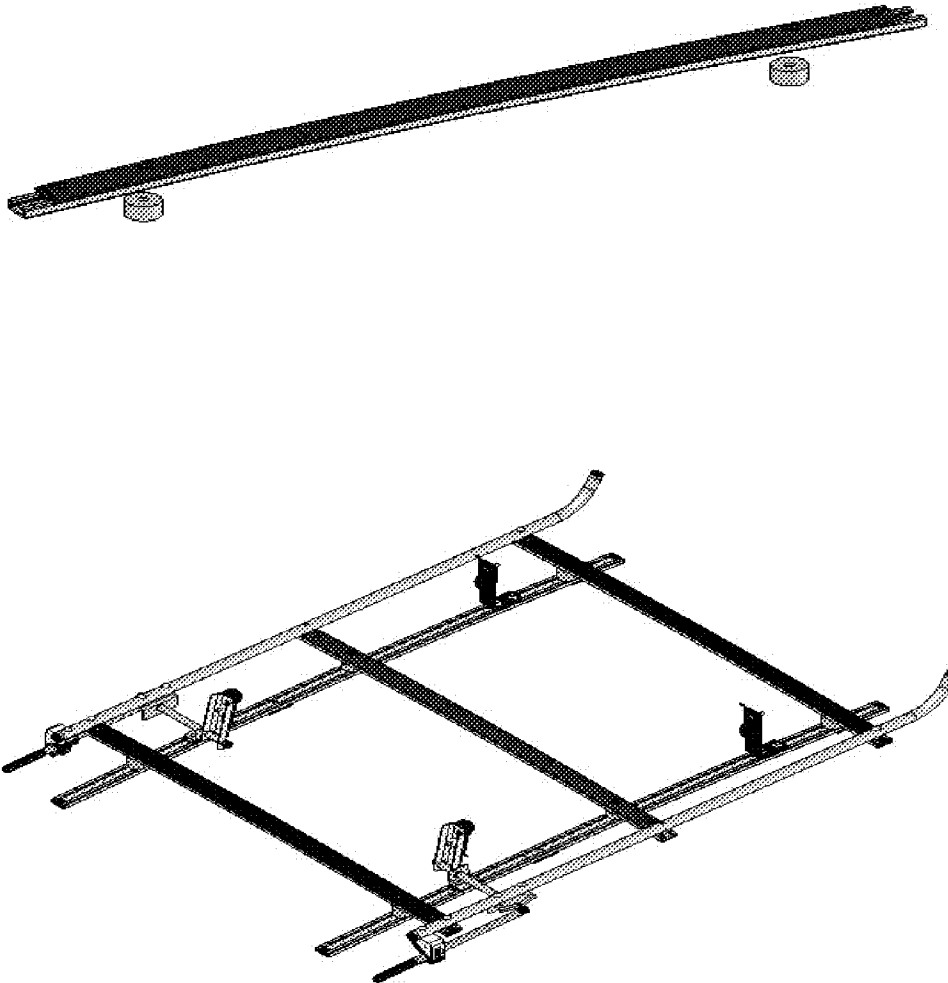

1BTCGL Installed on a 63-TC Grip-Lock Rack



BEFORE YOU START!

IMPORTANT INSTALLATION STEPS ARE DENOTED USING A STOP SIGN. THESE STEPS MUST BE PERFORMED AS SPECIFIED IN ORDER TO ENSURE A PROPER INSTALLATION AND MUST BE FOLLOWED IN ORDER TO MAINTAIN YOUR PRODUCT WARRANTY!



CRITICAL INFORMATION PERTAINING TO USER AND/OR VEHICLE SAFETY IS DENOTED USING A CAUTION SIGN. SAFETY ITEMS MUST BE STRICTLY ADHERED TO IN ORDER TO ENSURE A SAFE WORKING ENVIROMENT!



YOU WILL NEED THE FOLLOWING TOOLS IN ORDER TO COMPLETE THIS JOB.

| | |
|--|----------------------------------|
| | 5.0mm ALLEN WRENCH |
| | RATCHET WRENCH, WITH 1/2" SOCKET |

ALL FASTENERS USED IN THE ASSEMBLY AND INSTALLATION OF THIS PRODUCT SHOULD BE TIGHTENED TO THE SPECIFIED TORQUE AS LISTED WITH EACH FASTENER CALLOUT BOX.

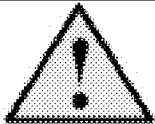

THE USE OF AIR OR ELECTRIC IMPACT TOOLS FOR THE ASSEMBLY OF FASTENERS IS NOT RECOMMENDED AND COULD CAUSE FASTENER FAILURE!



WARNING



THE USE OF DRILLS WITH INTEGRAL DRILL STOPS ALONG WITH PROPER INSPECTION FOR GAS TANK, GAS LINES, BRAKE LINES AND ELECTRICAL LINES PRIOR TO DRILLING ANY MOUNTING HOLES IS STRONGLY RECOMMENDED TO ENSURE THAT VEHICLE DAMAGE IS AVOIDED!



THE USE OF NON-STANDARD FASTENERS AND/OR DEVIATING FROM THE FASTENERS SPECIFIED IN THE INSTRUCTION (S) MAY VOID YOUR PRODUCT WARRANTY!



TO PREVENT EXHAUST FUMES FROM ENTERING THE VEHICLE, ALL HOLES SHOULD BE SEALED AT INSTALLATION WITH BUTYL OR SILICON SEALANT MATERIAL.





ALL DRILLED HOLES IN THE VEHICLE SHOULD HAVE THE RAW METAL EDGES SEALED WITH A SELF-ETCHING PRIMER TO RESIST CORROSION AND POTENTIAL FASTENER POINT FAILURE!

ADRIAN STEEL COMPANY • 906 JAMES ST. • ADRIAN, MI. 49221 • (517) 265-6194



1BTCGL Assembly and Installation Instructions

Whenever a plusnut is specified it is important that the proper size installation hole is provided.

| PLUSNUT SIZE | | DRILL SIZE <i>(with stop)</i> |
|--------------------------|---|-------------------------------|
| 1/4-20 PLUSNUT, FAS0052 |  | 3/8" DIAMETER |
| 5/16-18 PLUSNUT, FAS0091 |  | 1/2" DIAMETER |

FOR MOUNTING THROUGH A FLOOR MAT AND/OR CARPET

Position each item in desired location inside the vehicle and mark the floor mounting locations.

It is recommended that a drilling template be used to ensure an accurate placement of components is achieved for this installation.

Using the cutting tool, drill a pilot hole thru the mat/carpet and metal floor pan.

Spacer Use and Installation

3927-1
(SHOWN)

ALWAYS PLACE RECESSED PART OF FLOOR SPACER ON TOP OF PLUSNUT.

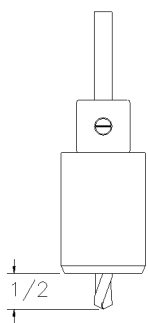

Placing the properly sized spacer on top of the vehicle floor pan will make your Adrian interior level, square, and sound. The view below shows the proper sized spacer for the different heights of the vehicle floor. Make sure to place the spacers with the plusnut relief surface down as shown.

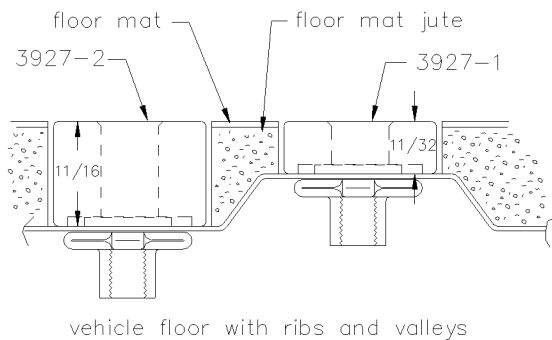
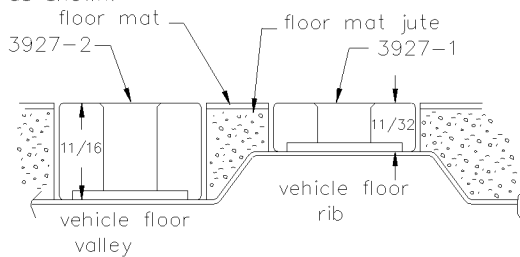

The location of various floor mounts will determine what spacer combination will be used. For example, an 11/32" spacer is used atop floor ribs, and an 11/16" high spacer is used atop floor valleys.





THE PROPER USE OF SPACERS IS REQUIRED WHEN MOUNTING OVER MAT/CARPET TO ENSURE THE METAL-TO-METAL CLAMP-UP, WHICH WILL PREVENT UNWANTED COMPONENT SHIFTING AND POTENTIAL FAILURE DURING USE.



STEP – 01 Assemble Wear Insert to Bow



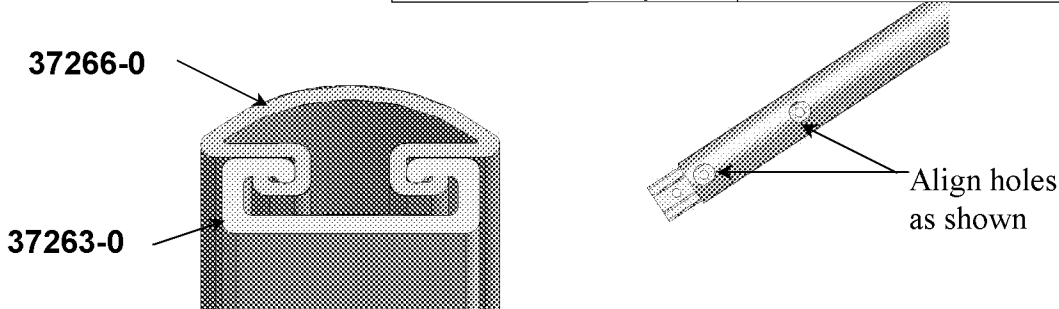

Use the following components for this step:

| | |
|---|---|
|  37263-0 Bow1 Req'd |  37266-0 Wear Insert 1 Req'd |
|---|---|



STEP – 02 Installation of 1BTCGL onto GRIP-LOCK Rack

Use the following components for this step:

| | | | |
|---|--|---|---|
|  35335-0 Slide 2 Req'd. |  FAS0242 5/16-18X 1.50 Hex Screw 2 Req'd |  FAS0588 5/16 Lock Washer 2 Req' |  37598-0 Spacer 2 Req'd |
|---|--|---|---|

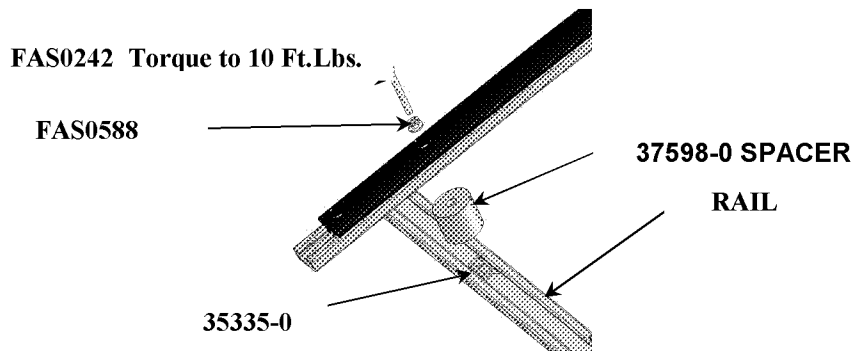

LOCATE THIS BOW BETWEEN FRONT AND REAR BOWS OF LADDER RACK, ALIGN END HOLE IN BOW WITH CENTER HOLE IN OUTER RAIL (TUBE).

1BTCGL shown on 63-TC

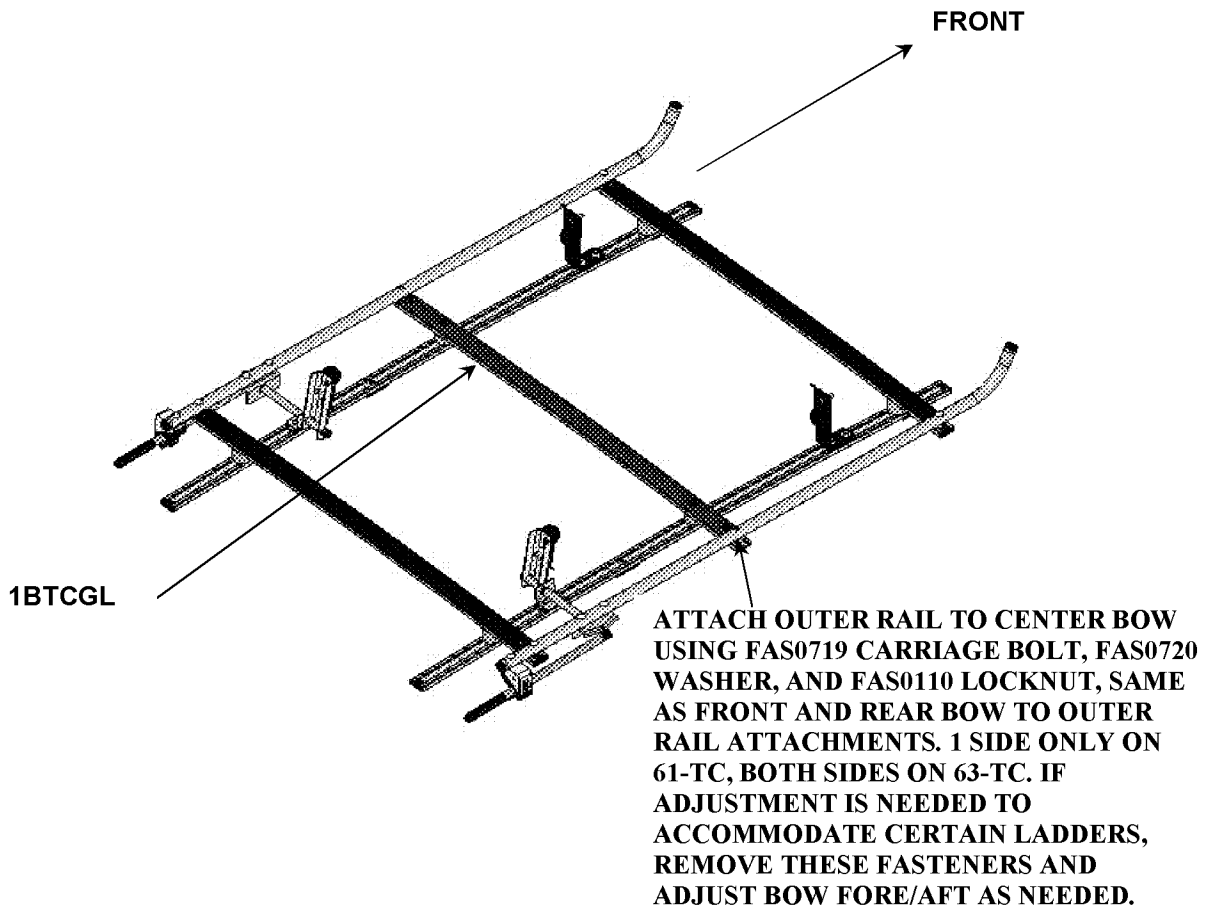

| | | |
|---|---|--|
| FAS0719 3/8-16 X 2.5 CRG BOLT  | FAS0720 3/8" FLAT WASHER  | FAS0110 3/8-16 LOCKNUT  |
|---|---|--|

STEP – 03

If this kit is being installed on a Rack that is already mounted on a vehicle, the following steps need to be taken :

- a) Remove 36496-0 End Caps from front of Rails
- b) Remove Screws and Washers that hold Front Bow and Ladder Stops to Rail Slides. Also remove Front Mounting Screw that attaches Rack to Roof using a 5mm hex Allen wrench.

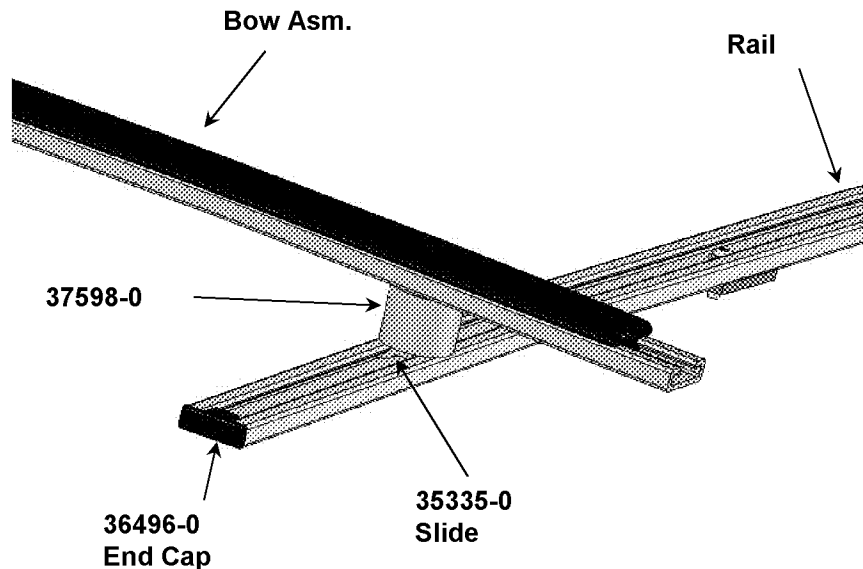

- c) Move these Slides rearward to desired location for Center Bow, 1BTCGL.
- d) Slip 1 new Slide, 35335-0, into each Rail, replace mounting screw using fresh Silicone and re-attach Front Bow Asm. and Ladder Stop.
- e) Replace End Caps.

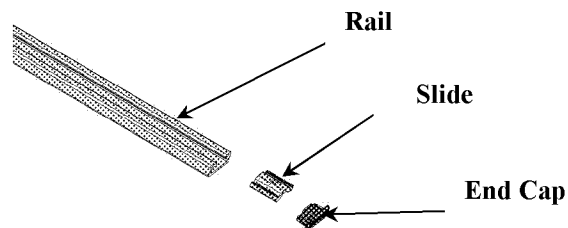

- f) If desired location of Center Bow is rearward of rear mounting screw attaching Rail to roof, these screws must be removed to allow Slides to pass and then replaced. This will require the use of a 5 mm Allen Wrench. Fresh Silicone should be applied to screw and washers prior to replacing.
- g) Attach 3rd Bow, adjust to desired location and tighten hex screws to 10 Ft.Lbs.



1BTCGL
Assembly and Installation Instructions



**DOUBLE-CHECK ALL FASTENER LOCATIONS TO BE
SURE THAT ALL FASTENERS ARE TIGHTENED TO
SPECIFICATIONS!**



**YOUR INSTALLATION IS NOW COMPLETE! STOW THIS COPY IN THE VEHICLE FOR FUTURE REFERENCE!
RECHECK ALL FASTENERS FOR TIGHTNESS AFTER 2 WEEKS, AND 6 WEEKS OF OPERATION!**