



PRODUCT WEIGHT

5.5 Lbs

WIDTH x DEPTH x HEIGHT

62" x 2" x 2"

CAPACITY

COLOR

Aluminum & Black

CATALOG NUMBER

1BPMCGL

PRODUCT FEATURES

CENTER BOW ADD-ON KIT FOR THE 63-PMC AND 2BPMC RACKS TO ALLOW THE TRANSPORT OF SHORT LADDERS ON ONE SIDE OF THE RACK WHILE MAINTAINING CENTER DISTANCE OF FRONT AND REAR BOWS FOR LONGER LADDERS AND CARGO. ALSO AVAILABLE IS AN UPRIGHT KIT FOR USE WITH THIS KIT ON 2BPMC UTILITY RACK. ALUMINUM CONSTRUCTION WITH COMPOSITE SURFACE FOR LOAD PROTECTION AND STAINLESS STEEL FASTENERS.

SEE PAGE 2 FOR APPLICATION NOTES AND ACCESSORIES, OTHER PRODUCTS THAT WORK WITH THIS UNIT.



CATALOG NUMBER 1BPMCGL

PRODUCT APPLICATION

THIS PRODUCT IS FOR USE WITH THE 63-PMC AND 2BPMC RACKS FOR THE DODGE PROMASTER CITY

ACCESSORIES THAT WILL WORK WITH THIS PRODUCT

CATALOG NUMBER

61TCSSUR

DESCRIPTION

**UTILITY ADD-ON KIT
(WHEN USED ON 2BPMC)**

SPECIAL APPLICATION NOTES

Additional accessories may be compatible with this product. Please consult with ADRIAN STEEL ENGINEERING to review specific applications not listed here.

Introduction / Comments:

THIS KIT IS DESIGNED TO PROVIDE A MEANS TO CARRY SHORT STEP LADDERS ON THE 63-PMC OR 2BPMC RACKS. BE SURE ANY LOAD OR LADDER IS PROPERLY SECURED TO THE RACK PRIOR TO MOVING VEHICLE.

Note:

It is advised that all fasteners used in this assembly and installation of this Rack should be checked for tightness at the following intervals: @ 2-weeks and again @ 6-weeks of operation. This preventive maintenance step must be completed to ensure your package gives you long service life.

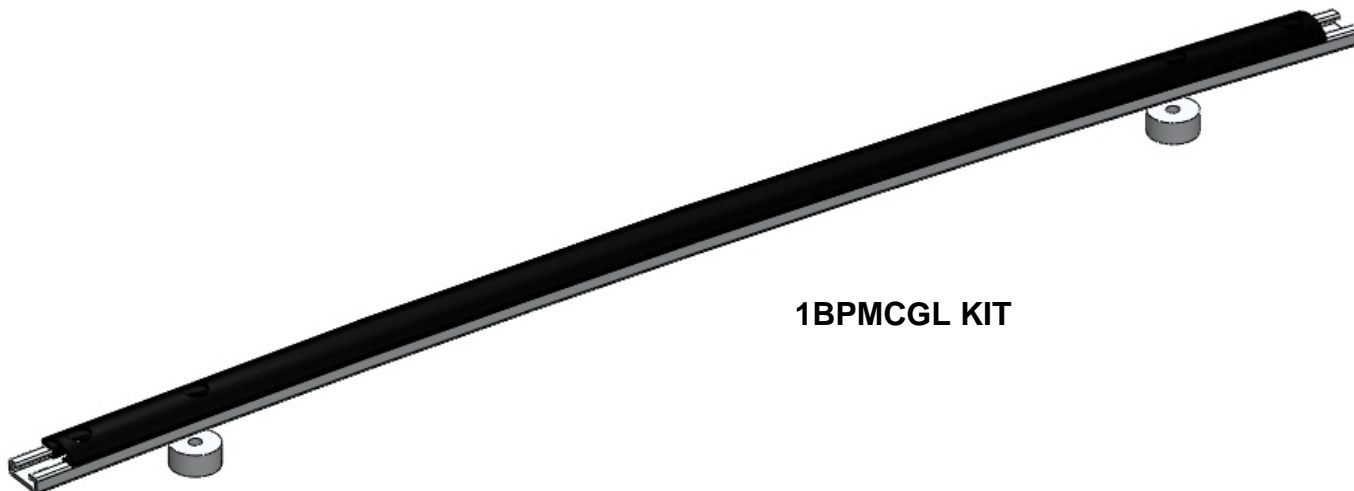

1BPMCGL KIT



**1BPMCGL INSTALLED
ON 63-PMC GRIP-LOCK
LADDER RACK**

**1BPMCGL
CENTER BOW KIT FOR PROMASTER CITY VAN**

- PRECAUTIONS -





 **CAUTION** 
**THE USE OF AIR IMPACT TOOLS CAN
OVER-TORQUE FASTENERS AND
CAUSE FASTENER FAILURE!**



 **CAUTION** 
**ALL INSTALLATION HOLES SHOULD BE SEALED
WITH SILICON OR BUTYL SEALANT TO PREVENT
EXHAUST FUMES FROM ENTERING THE VEHICLE!**



 **DANGER** 
**INSPECT FOR FUEL TANK, FUEL LINES, BRAKE LINES, HIGH
VOLTAGE BATTERIES AND ELECTRICAL LINES PRIOR TO
DRILLING TO AVOID DAMAGING CRITICAL VEHICLE SYSTEMS
OR INJURY TO INSTALLER DURING INSTALLATION PROCESS!**



 **CAUTION** 
**TO AVOID DAMAGING THE VEHICLE ALWAYS
USE DRILL STOPS WHEN DRILLING ANY IN-
STALLATION HOLES!**



- IMPORTANT WARRANTY REQUIREMENTS -

1. SUBSTITUTING ADRIAN STEEL SPECIFIED FASTENERS FOR ASSEMBLY AND/OR INSTALLATION WILL VOID YOUR PRODUCT WARRANTY.
2. ALL HOLES DRILLED INTO VEHICLE SHOULD HAVE THE RAW METAL EDGES SEALED WITH A SELF-ETCHING PRIMER TO RESIST CORROSION AND POTENTIAL FASTENER POINT FAILURE.
3. ALL FASTENERS USED IN THE INSTALLATION OF THIS PRODUCT SHOULD BE TIGHTENED TO THE TORQUE(S) SPECIFIED IN THESE INSTRUCTIONS.
4. THESE INSTRUCTIONS SHOULD BE KEPT WITH THE VEHICLE.

THE BASIC TOOLS NEEDED FOR MOST INSTALLATIONS



DRILL



DRILL BIT WITH
STOP



RATCHET, SOCKETS
AND/OR WRENCHES



SCREWDRIVERS



MEASURING TAPE

ADDITIONAL TOOLS MAY BE NEEDED FOR THIS INSTALLATION AND THEY WILL BE IDENTIFIED IN THE STEPS THAT FOLLOW.

BAG1BNV2GL
FASTENER BAG FOR CENTER BOW KIT

ITEM NO.	PART NUMBER	DESCRIPTION	BAG1BNV200GL/QTY.
1	35335-0	SLIDE	2
2	FAS0588	Washer, Lock, Split, 5/16, SS	4
3	BAG0406-A	4" X 6" 3MIL AUTOBAG	1
4	FAS0242	Screw, Hex Hd, 5/16-18x1.50 Stainless Steel	4
5	36496-0	END CAP	2
6	FAS0552	Washer, Flat, 5/16, SST	2

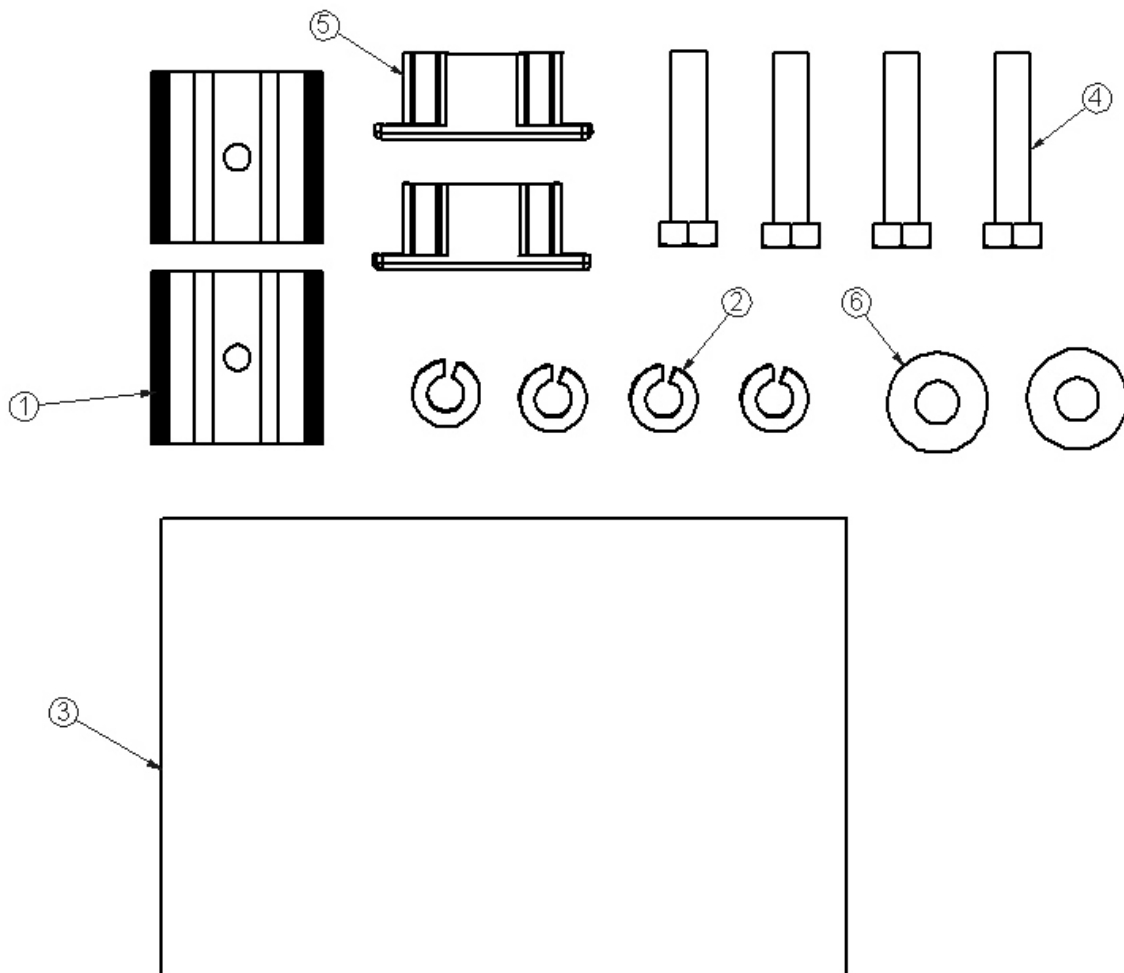



ASSEMBLE CENTER BOW KIT

SLIDE WEAR INSERT INTO BOW UNTIL INNER HOLES ALIGN. ASSEMBLE ADDITIONAL SLIDE INTO EACH ROOF RAIL ASM NEAR CENTER OF RAIL. INSTALL SPACER BETWEEN BOW AND ROOF RAIL, FASTEN WITH FAS0242 SCREW WITH FAS0588 LOCK WASHER INTO SLIDE. ASSEMBLE CENTER BOW TO OUTER RAIL OF GRIP-LOCK RACK WITH FAS0242, FAS0552 AND FAS0588 WASHERS AS SHOWN, INTO RIVNUT IN OUTER RAIL. TORQUE TO SPEC.

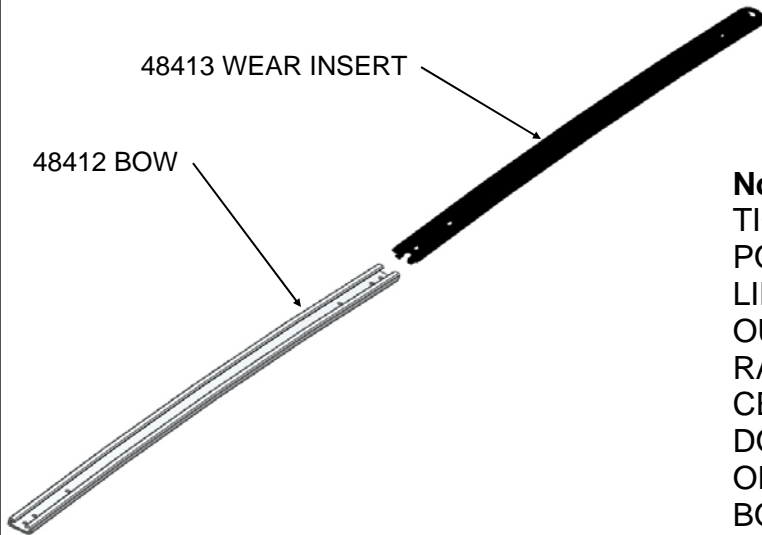

Note: IF FRONT CROSSBOW IS POSITIONED BETWEEN THE 2 FRONT MTG POINTS, THE CENTER BOW WILL **NOT** LINE UP WITH THE RIVNUT IN THE OUTER RAIL OF THE GRIP-LOCK RACK DUE TO THE LOCATION OF THE CENTER ROOF MTG SCREW. EITHER DO NOT BOLT BOW TO OUTER RAIL, OR REPOSITION FRONT AND REAR BOWS REARWARD 3 TO 4"

