

# GM EXPRESS/SAVANA & CITY EXPRESS CARGO VAN EQUIPMENT



# ADRIAN STEEL®

Cargo Management Solutions for Commercial Vehicles



### TIME IS MONEY! GET ON THE ROAD WITH EVERYTHING YOU NEED!

Adrian Steel has the storage products you need, with a nationwide distributor network for professional installation. This catalog will help you set up your work van with the equipment you need to get the job done. Start with a partition to keep your cargo in the cargo area. Choose the shelving and modules for the curb and street side that fit your business needs. Or, choose a pre-designed trade package to start from. Add the accessories you need to make your van more organized. Carry ladders or cargo on your roof? Check out the variety of ladder and utility racks available. The options are many, so if you don't know where to start contact your local Adrian Steel distributor for the expert advice you are looking for.



**\$1200 UPFIT CASH\***  
ON EXPRESS & SAVANA

**\$350 UPFIT CASH\***  
ON CITY EXPRESS

### MAKE YOUR CARGO VAN WORK READY WITH THE GM BUSINESS CHOICE PROGRAM.

Get The Ultimate In Flexibility When You Take Upfit Cash And Apply It Towards Any Adrian Steel Upfit, Including Commerical Curb Appeal!

#### WHAT IS GM BUSINESS CHOICE?

GM Business Choice is an incentive program designed specifically for business owners who use vehicles in the day-to-day operation of their business and not solely for transportation purposes. This incentive is available when you purchase or lease an eligible Chevrolet or GMC cargo van.

#### SAVE TIME!

Don't go searching around town for product you need for your GM Cargo Van. Adrian Steel has a comprehensive line of cargo management solutions to get your van upfitted for your trade! You can leave the dealership with a cargo van that is ready to go to work!

#### COMMERCIAL EXPERTS!

Your GM Dealership and Adrian Steel Distributor can guide you through the upfit process. Utilize their product expertise to get a complete, turn-key work vehicle.

#### PRODUCT FLEXIBILITY!

Create a work ready van, designed by you, for your specific cargo carrying needs! Organize the interior of your van to suit your trade with Adrian Steel's modular product line. Start with the essentials: a partition, shelving and a roof rack. Then get trade specific by adding drawer units, door kits, hook bars, floor drawers and more!

#### PROGRAM TIMEFRAME & DETAILS\*

The 2016 GM Business Choice Program runs through September 30, 2016. You must purchase or lease your vehicle and take delivery during the program time frame and provide proof of your business. Program is not available in all areas and may not be compatible with other offers or incentive programs. Consult your dealer for complete program details. For more information, please contact your local Adrian Steel Distributor.

\*US program only. See website for GM Canada program details. Program subject to change without notice.

GM is a registered trademark of the General Motors Corporation.

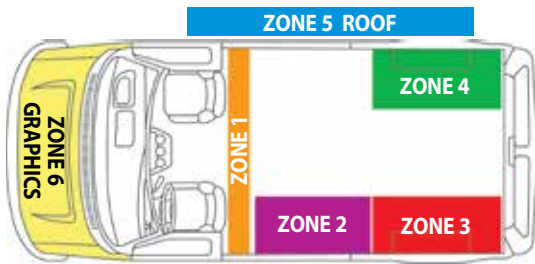

### ZONE 1 PARTITION

- Choose partition style: solid or perforated. Do you want a hinged door? See pgs 6-7.
- Choose the standard or 3" setback wing kit and add accessories.

### ZONES 2, 3, 4 CURBSIDE & STREETSIDE

- Use layout diagrams to determine the amount of space available.
- Choose from a variety of shelving units and modules that will best organize the tools and equipment you need to carry.
- Or, choose a Work Ready Upfit, complete with a trade specific, pre-designed interior and custom graphics package.

### ZONE 5 ROOF

- What do you need to carry?
- Choose from LoadsRite, Grip-Lock, and Utility racks.
- Add rack accessories including step ladder kits, ratchet straps, conduit carriers and more.

### ZONE 6 VEHICLE GRAPHICS

- Stand out in the crowd!
- Vehicle graphics are the most cost effective form of advertising!

### ADDITIONAL STORAGE

- Determine the space needed for specialty equipment.
- Add accessories to shelving and partition
- Hooks, drawers, files, screens, and more.

**Need some help?**  
**Contact your local distributor!**  
 They can provide a wealth of information about utilizing the cargo space in your work van.  
 Find your local distributor online at [adriansteel.com](http://adriansteel.com).

### GM LONG WHEELBASE VAN 1996-ON

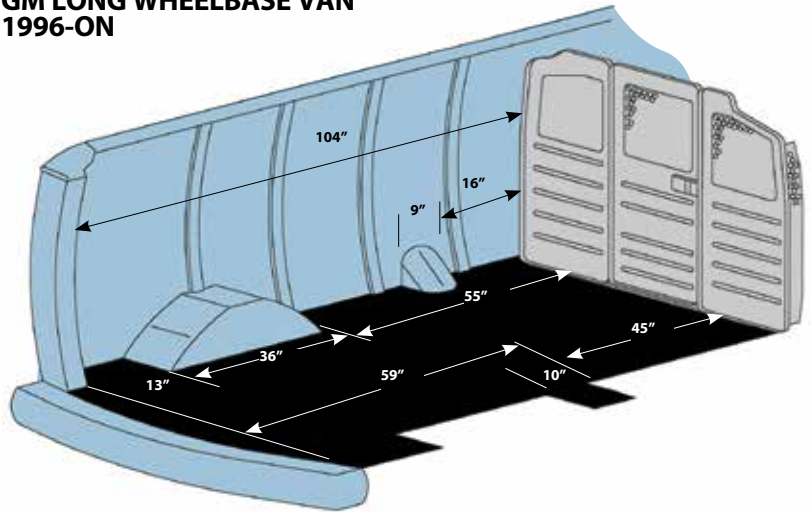

### GM EXTENDED LONG WHEELBASE VAN 1996-ON

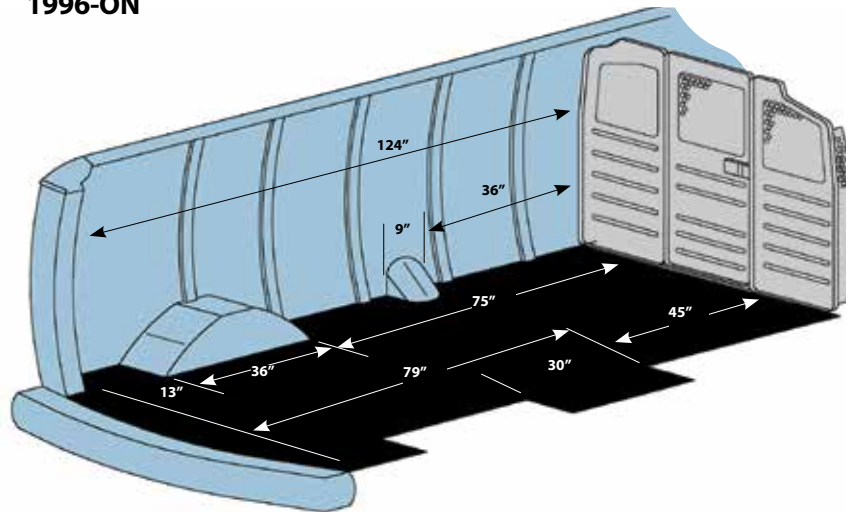

### CITY EXPRESS WITH STEEL PARTITION 2015-ON

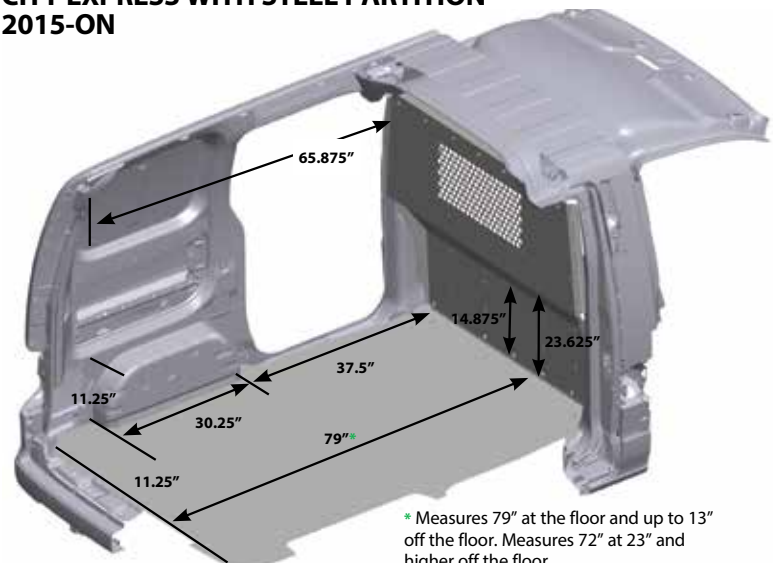

\* Measures 79" at the roof and up to 13" off the floor. Measures 72" at 23" and higher off the floor.

All illustrations, photos and specifications in this publication are based on the latest product information available at the time of content approval.

The right is reserved to make changes at any time, without notice, in materials, specifications and models, and also to discontinue models.

Note: Dimensions for reference only. Measure your van or contact your distributor for your exact needs.



## MOBILIZE YOUR BRAND WITH ADRIAN STEEL'S VEHICLE GRAPHICS PROGRAM.

Adrian Steel and Signature Graphics have partnered to be able to provide you with a complete, work ready van. Go on-line to create the look you want, then have your graphics and interior package installed all at the same time at your local Adrian Steel distributor. This saves time and gets your new van in service and working for you quicker.

## NEW VAN, NEW LOOK

The key to commercial graphics is setting yourself apart from the competition. Effective use of color, direct messaging and simple brand identification turn your vehicle into a viable advertising tool.

### WHEN CONSIDERING YOUR DESIGN, START WITH THE BASICS:

- Name and logo
- Phone number and website
- Services you offer
- Your essential message
- Pictures of your product



## BRANDING

More than just your logo, your brand is the total package presented at every point of public contact.

Brands can provide customers with instant and powerful recognition of your business and the services or products that you offer. When you take your brand to the streets, you make an impression on every person you pass.

Completely redesign or just upgrade your image as part of your brand strategy to help grow your business. When it comes to graphics, sometimes less can mean more. While full wraps are an attractive option that we offer, a budget conscious small business owner can have a significant impact on their image without covering the entire vehicle.

## IT'S EASY!

### Step 1

User logs in and selects vehicle year, make, model, and options. The site is preloaded with most commercial vans and pickups.

### Step 2

A blank vehicle will appear on the screen and you are ready to begin designing. The design tool allows users to personalize a professionally designed template, or create a new design from scratch.

### Step 3

Once you have finished your new vehicle design you can instantly price the production and installation by clicking the estimate button. Print your quote to share with your local dealer at the time of your vehicle purchase and include the cost in your financing. Within 7-10 days, your vehicle will be ready to roll!



**Start Now at [www.commercialcurbappeal.com](http://www.commercialcurbappeal.com)!**

# TO WRAP OR NOT TO WRAP?

Take a look at these examples designed and priced on [CommercialCurbAppeal.com](http://CommercialCurbAppeal.com)

**\$1800** Simple design on the side.  
Logo on hood or rear door.



**\$2200** More complex design on the side.  
Logo on hood and/or rear door.

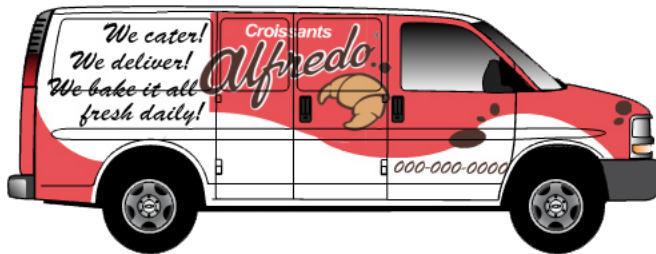

**\$4000** A full wrap with a complex design covering all possible areas.

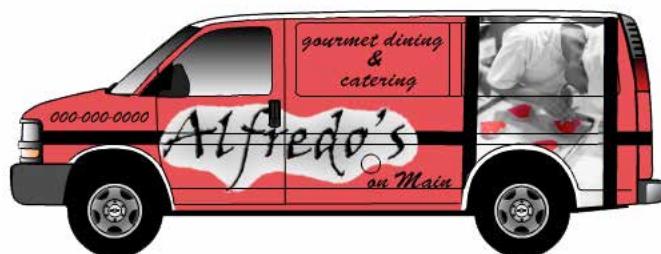

## VINYL 101

CommercialCurbAppeal.com produces your graphics on commercial grade vinyls that are the benchmark of the fleet industry. Fit, finish, durability and removability are all critical when considering your investment so they look as good on day 1 as day 1000.

DIRECTV, Best Buy, TRANE, Geek Squad and Penske are all produced with the exact same films. Rest assured that the 3/36 warranty through your Adrian Steel Distributor includes the graphics.

Installation is made simple through your dealer or Adrian Steel distributor.

## NEED MORE REASONS WHY?

CommercialCurbAppeal.com allows you to personalize your vehicle and be sure it positively represents your business.

By adding graphics to the upfitting process your vehicle will be in service faster, saving you time and money.

Graphics through CCA can often be added to your financing package, amortizing your new look over the life of your vehicle.

Graphics will help increase your vehicle visibility and build brand awareness in the community.

Comparatively, vehicle graphics are more affordable than most other advertising options.

BEING NOTICED IS  
**EVERYTHING!**

[www.commercialcurbappeal.com](http://www.commercialcurbappeal.com)

\*Commercial Curb Appeal not available in Canada.

**ADRIAN STEEL PARTITIONS KEEP CARGO WHERE IT BELONGS, IN THE CARGO AREA!**

Partitions are sold as panel kits and wing kits. Please see application chart below to confirm the appropriate panel kit and wing kit for your vehicle. Partition panel kits and wing kits include assembly and installation fasteners for base van trim level. Higher trim levels may require modifying trim or partition. Wing kits are available in a standard position or an extended position for more leg room.

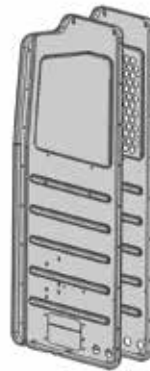

**S1 Solid**  
**S2 Perforated Top**  
Panels mount behind driver seat.



**M1 Solid**  
**M2 Perforated Top**  
Fixed center panels can be hinged as key-locking doors

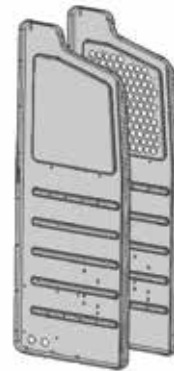

**C1 Solid**  
**C2 Perforated top**  
Panels mount behind passenger seat.



**Wing Kits**  
Available as standard setback or with extra 3" setback.

**S-M-C SERIES PARTITIONS FOR EXPRESS & SAVANA VANS**

- Choose from solid or perforated panels.
- Partition mounts behind the B-pillar allowing for maximum cab comfort.
- Center M panels can be fixed or hinged with a key-locking door. All hinged door partitions come standard with two 6" hinges, bulb seal and a slam latch. These features reduce vibration noise.
- Partitions feature pre-drilled holes for adding accessories easily, and larger pass-through holes for routing wiring.
- Stamped steel panels reduce product weight without sacrificing strength.

Note: Extended wing kits reduce the amount of cargo space. Please confirm the interior layout of the van package to confirm that the extended wing kit has adequate room needed for installation. 3" extended wings not compatible with GM Pro/Access vans.

| MODEL                             | DESCRIPTION                       | WING KIT                |
|-----------------------------------|-----------------------------------|-------------------------|
| <b>FIXED CENTER PANEL</b>         |                                   |                         |
| S1M1C1FSV                         | Solid panels                      | WKC1FSVGM<br>WKC1FSVGM3 |
| S1M2C1FSV                         | Center panel perforated           | WKC1FSVGM<br>WKC1FSVGM3 |
| S1M2C2FSV                         | Center and Curb panels perforated | WKC1FSVGM<br>WKC1FSVGM3 |
| S2M2C2FSV                         | All panels perforated             | WKC2FSVGM<br>WKC2FSVGM3 |
| <b>HINGED CENTER PANEL "DOOR"</b> |                                   |                         |
| S1M1HC1FSV                        | Solid panels                      | WKC1FSVGM<br>WKC1FSVGM3 |
| S1M2HC1FSV                        | Center panel perforated           | WKC1FSVGM<br>WKC1FSVGM3 |
| S1M2HC2FSV                        | Center and Curb panels perforated | WKC1FSVGM<br>WKC1FSVGM3 |
| S2M2HC2FSV                        | All panels perforated             | WKC1FSVGM<br>WKC1FSVGM3 |

See more partition images and accessories on-line at [adriansteel.com](http://adriansteel.com).



**X SERIES PARTITION**

Get maximum side and rear view mirror visibility with X Series partitions. X Series partitions are designed with a large perforated upper panel, eliminating obstructions to driver side and rear views. Made from 16-gauge steel and finished with our Steel-Cote powder coat paint.

| MODEL                     | DESCRIPTION             | WING KIT                |
|---------------------------|-------------------------|-------------------------|
| <b>X-SERIES PARTITION</b> |                         |                         |
| X1FSV                     | fits Express/Savana FSV | WKX1FSVGM<br>WKX1FSVGM3 |

**STEEL AND WIRE PARTITION OPTIONS FOR THE CITY EXPRESS**



**P2NV2S  
STEEL PARTITION  
FOR CITY EXPRESS**

- Features all steel panels to safeguard the cab area against moving or shifting cargo.
- Recessed design allows for maximum adjustability of front seats.
- Perforated window provides full visibility of your cargo area and rear windows.
- Steel header and full perimeter wings provide optimal security.
- Recessed bottom panel provides room for a 6 foot step ladder or other accessories.

Note: Wing kits are not needed.



**P2NV2FW  
WIRE MESH PARTITION  
FOR CITY EXPRESS**

- Provides maximum visibility while safeguarding your van cab area against moving, shifting cargo.
- Recessed design allows for maximum adjustability of your driver and passenger seats.
- Lightweight and economical, without sacrificing safety and security.

**Partition Accessories**

**Express/Savana**



**TA1 Hook Bar** 2" x 12" bar mounts to partition or shelving. Four welded hooks with 2" hanger opening.

**PDK1 Hinged Door Kit** converts M-Series fixed center panel into hinged door with keyed slam latch. Includes two 6" hinges, bulb seal and a slam latch that reduce vibration noise.



**PA9 First Aid Box Tray** secures first aid box to partition or other vertical surface. Measures: 11" W, 4-1/2" H, 3-1/8" D

**PA7 Triangle Reflector Kit** Includes reflector kit with metal pocket holder, I.C.C. approved.



**PA8 1-A: 10-BC Fire Extinguisher** is a rechargeable, 2-1/2 lb. dry chemical extinguisher. Stops Class A, B and C fires. Complete with charge gauge and mounting bracket.

**PA10 Practice Holder** Organizes paperwork. Measures: 12" W, 7" H, 5" D.

**TH30 or TH50 Refrigerant Tank Holder** holds 30lb. or 50lb. tank to partition or other vertical surface.

**Partition Plexiglass Cover Panels** (not shown) install over the perforations of the partition to help with climate control in the cab.

**PA5-1:** S panel, **PA5-2:** M panel, **PA5-6GMS:** C panel.

**PA5-3GMS:** fits X-Series partition



**THE NEXT GENERATION OF CARGO MANAGEMENT SOLUTIONS**

Tools, equipment and cargo come in all shapes and sizes and until now, there hasn't been a shelving unit that is **truly adjustable**. The ADseries is the first of it's kind where, with only a screwdriver, you can simply remove the front shelf bolts and move the shelf where you need it. Shelves can be adjusted in one inch increments and provide the most flexible shelving solution available.

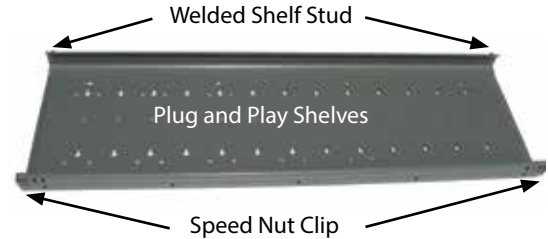

**TRULY ADJUSTABLE SHELVES**

All you need is a phillips head screwdriver! The unique shelf design features rear shelf studs that lock the shelves in place and speed nut clips that allow you to attach bolt on easily! Simply remove two bolts from the speed nut clips at the front lip of the shelf, tilt the shelf upwards to disengage the rear studs, move the shelf to your desired location, insert the rear shelf studs, reattach the bolts and you're done!



**ADAPTABLE INTERIOR**

Everyone likes to set their work van up their own way. The ADseries allows you position the shelving where you need it. Exclusive to the ADseries, the unique rail system enables you to reposition the shelving along the rail, increasing the available space for trade specific equipment. All of this is done without removing bolts, plugging holes and redrilling the van! The 6" knock out of the stamped steel end panels provides a 48" floor space to accommodate 4'x 8' sheet goods (up to 22 sheets of 1/4" drywall or a combination of thicknesses).



**ADD ACCESSORIES**

Businesses change over time and your van interior should be able to change with your needs. Plug and Play shelves have prepunched holes that allow adding storage solutions easily! ADseries dividers simply snap in place, drawer units and door kits simply bolt into place. Many Adrian Steel accessories can be added to the ADseries shelving with the rail adapter kits and end panel brackets.

| MODEL      | SIZE                     | DESCRIPTION                      |
|------------|--------------------------|----------------------------------|
| AD28NV2    | 28"W x 46"H x 14"D       | fits City Express                |
| AD32FP     | 32"W x 46"H x 14"D       | fits Express/Savana/City Express |
| AD44FP     | 44"W x 46"H x 14"D       | fits Express/Savana              |
| AD50FP     | 50"W x 46"H x 14"D       | fits Express/Savana              |
| RKFSVLWB   | Rail Kit, LWB            | fits Express/Savana              |
| RKFSVXLWB  | Rail Kit, XLWB           | fits Express/Savana              |
| RK67NV2-CS | Rail Kit-full curbside   | fits City Express                |
| RK67NV2-SS | Rail Kit-full streetside | fits City Express                |
| RKNV2-CS   | Rail Kit-curbside        | fits City Express                |
| RKNV2-SS   | Rail Kit-streetside      | fits City Express                |

| MODEL    | SIZE/DESCRIPTION                            |
|----------|---|
| DV14C1   | Divider for ADseries shelf/Single           |
| DV14C8   | Divider for ADseries shelf/8 Pack           |
| DK3008   | 8" High Door Kit/AD32FP                     |
| DK3010   | 10" High Door Kit/AD44FP                    |
| DK4208   | 8" High Door Kit/AD44FP                     |
| DK4210   | 10" High Door Kit/AD44FP                    |
| DK4808   | 8" High Door Kit/AD50FP                     |
| DK4810   | 10" High Door Kit/AD50FP                    |
| DK532    | Door Kit/AD32FP                             |
| BRK14EPS | End Panel Bracket To Add on Accessories     |
| RKA1     | Rail Kit Adapter/See list at right          |
| RKA3     | Rail Kit Adapter3/See list at right         |
| RKA4     | Rail Kit Adapter4/See list at right         |
| RKABRK1  | Rail Kit Adapter/End Panel Bracket/See list |
| RKABRK2  | Rail Kit Adapter/17A                        |
| RKAWTR   | Rail Kit Adapter/Welded Tank Racks          |
| RKA919   | Rail Kit Adapter/#9, #19, #919 Drawer Units |
| 35325-G  | 32" Long Shelf                              |
| 35327-G  | 44" Long Shelf                              |
| 35328-G  | 50" Long Shelf                              |

- RKA1** – Rail Adapter Kit1  
Use with: CB2, CB3, CB4 (uses 2)
- RKA3** – Rail Adapter Kit3  
Use with: #1, #12, #2, #8, DC Units, 17A, CRH2, TA19, TA5
- RKA4** – Rail Adapter Kit4  
Use with: CL1446D/R, #40, KDRH2, KD Shelving Units, #33, #3, #33W, JD Shelving
- BRK14EPS** – ADseries end panel accessory attachment bracket.  
Use with: 17A, CB5, 43, TA19, TA20, WRH5, UH10/25/50, PA9, PA8, ACT3/4, PA11, AGSCH2, PA7, TH30, TH50, TA5
- RKABRK1** – Used with TA19, TA20, TA5

Note: Rails are not included with the shelf units.  
Rail kits must be ordered separately.  
Note: Shelves have the following weight ratings:  
Shelves positioned with the shelf lip facing up have a rating of 100 lbs. per shelf evenly distributed.  
Shelves positioned with the shelf lip facing down have a rating of 200 lbs. per shelf evenly distributed.



### CONFIGURE SHELF SPACING TO YOUR SPECIFIC CARGO MANAGEMENT NEEDS.

Adrian Steel Adjustable Shelving is available in narrow, 10" units up through extra long, 60" units and are designed to best utilize the space within your van. Set shelf space to fit your particular needs. Shelf lips keep items from rolling off shelf while in transit. Locking Door Kits convert a shelf into an enclosed, locking cabinet.

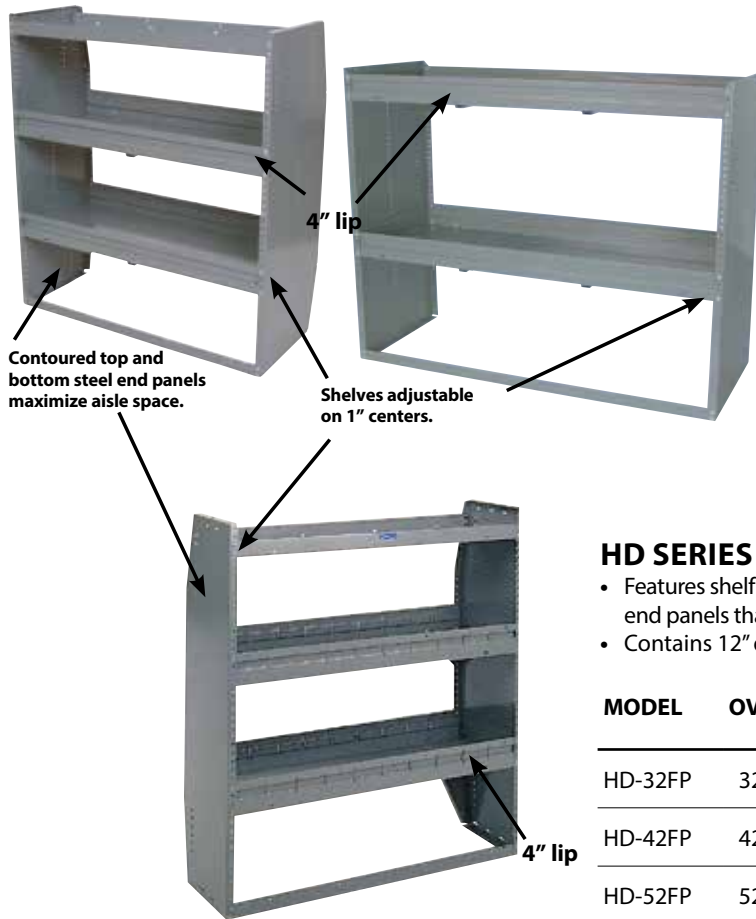

### JD SERIES JUMBO DEEP SHELVING

- Available in 18" and 24" depths.
  - Shelf gussets and floor rail provide extra strength.
  - 18" deep units contain one 14" and two 18" deep shelves.
  - 24" deep units have squared end panels and two shelves.
- See chart.

| MODEL  | OVERALL SIZE       | OPEN SHELF SPACE |
|--------|--------------------|------------------|
| JD42FP | 42"W x 46"H x 18"D | 14.58 sq ft      |
| JD52FP | 52"W x 46"H x 18"D | 18.56 sq ft      |
| JD48FP | 48"W x 48"H x 24"D | 20.21 sq ft      |
| JD60FP | 60"W x 48"H x 24"D | 20 sq ft         |

### HD SERIES HEAVY DUTY SHELVING

- Features shelf gussets and full floor-rail that provide extra strength, and contoured end panels that maximize aisle space.
- Contains 12" deep top tray with 2" lip and two 14" deep shelves with 4" lip.

| MODEL   | OVERALL SIZE       | DOOR POSITION | DOOR KIT MODEL | OPEN SHELF SPACE |
|---------|--------------------|---------------|----------------|------------------|
| HD-32FP | 32"W x 46"H x 14"D | Shelf         | DK532*         | 8.89 sq ft       |
|         |                    | Floor         | DK532A         |                  |
| HD-42FP | 42"W x 46"H x 14"D | Shelf         | DK542*         | 11.67 sq ft      |
|         |                    | Floor         | DK544          |                  |
| HD-52FP | 52"W x 46"H x 14"D | Shelf         | DK552*         | 14.44 sq ft      |
|         |                    | Floor         | DK552A         |                  |

\* Back panel included with door kit



### KD SHELVING

- KD shelf racks feature shelves that are fully adjustable on 1" centers.
- #3 and #33 feature solid end and back panels and four adjustable shelves.
- The #33W and 33WB have welded, contoured end panels and contain two welded shelves and three adjustable shelves.
- The 33WB includes four removable plastic bins with dividers.

| MODEL | OVERALL SIZE       | SHELF LIP | OPEN SHELF SPACE |
|-------|--------------------|-----------|------------------|
| 3     | 18"W x 46"H x 12"D | 2"        | 6 sq ft          |
| 33    | 12"W x 46"H x 12"D | 1"        | 4 sq ft          |
| 33W   | 10"W x 46"H x 14"D | 1"        | 4.71 sq ft       |
| 33WB  | 10"W x 46"H x 14"D | 1"        | N/A              |

### ADRIAN'S 44 SERIES OF WELDED SHELVING IS SOLID, STRONG AND FUNCTIONAL.

The 44 Series features a top shelf that has been lowered to be more functional allowing you to divide the shelves or add our popular blue bins. The mid and lower shelves are more functional with the ability to add door kits, DC drawer units, Lock and Latch drawer units, dividers and blue bins. The best selling shelf unit just got better.

#### Features and Benefits

- All shelves welded to end panels – greater weight capacity and reduces cargo noise.
- Contoured end panels provide a flush fit to van wall and maximizes aisle space.
- Welded back panel for containment and reinforcement.
- Shelving can be installed in any position within the van.
- All shelving is finished with Steel Cote™ – a powder coat, diamond-hard finish that resists scratching and chipping better than standard paint finishes.
- Three sizes available – 32", 42" and 50" wide models.

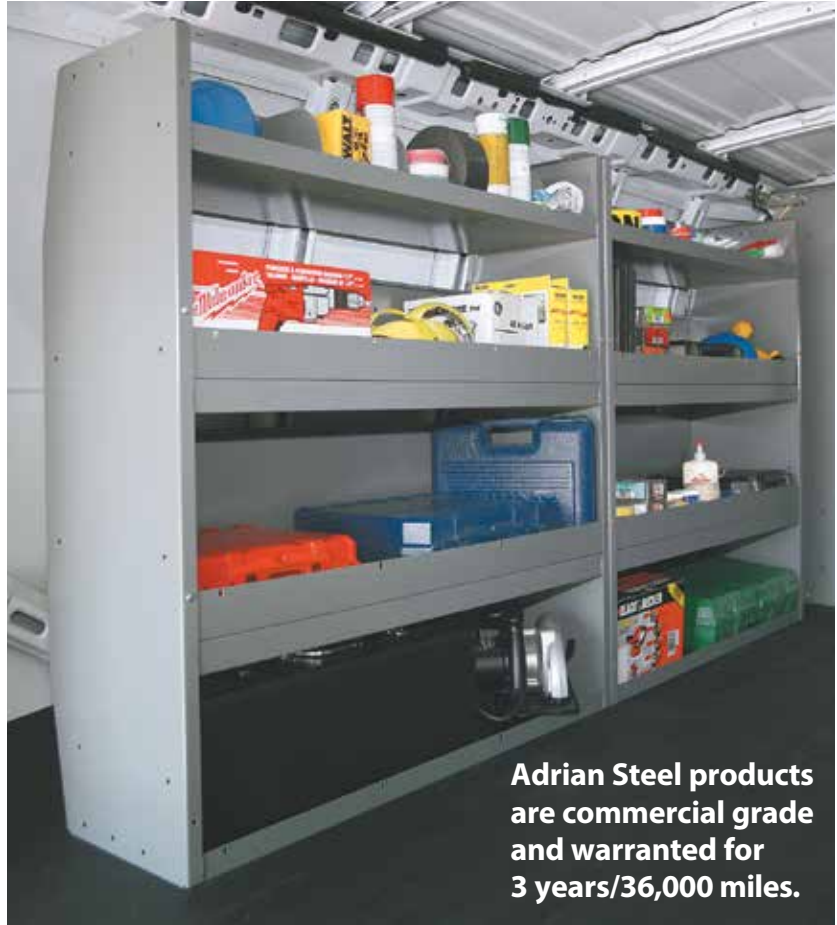

**Adrian Steel products are commercial grade and warranted for 3 years/36,000 miles.**

### HEAVY DUTY UTILITY SHELVES

- Constructed from heavier gauge steel.
- Welded dividers maximize carrying capacity.
- Divided top tray is 3" deep for increased rigidity.



**No. 18 Heavy Duty Utility Shelf**  
Measures 36"W x 22"H x 12"D



**NOW AVAILABLE IN 32", 42" & 50" LENGTHS**

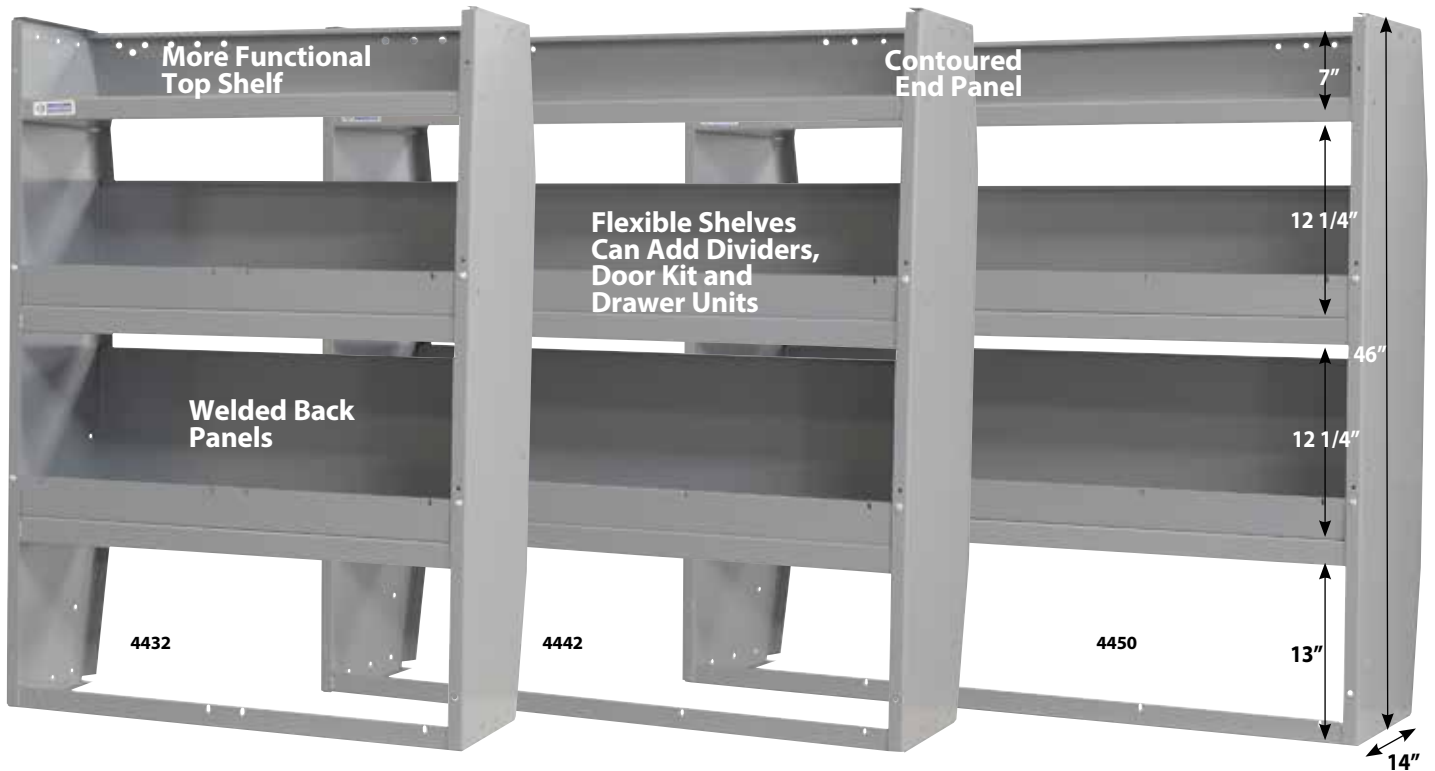

| MODEL | DESCRIPTION                         |
|-------|-------------------------------------|
| 4432  | Welded Cabinet - 32"W x 46"H x 14"D |
| 4442  | Welded Cabinet - 42"W x 46"H x 14"D |
| 4450  | Welded Cabinet - 50"W x 46"H x 14"D |



Contoured top and bottom steel end panels maximize aisle space.

**ACCESSORIES FOR WELDED SHELVING**

Upgrade the 44 Series with Dividers, DC Drawer Units, Lock & Latch drawer units, Door Kits and our popular #28 Blue Bins!

Plug & Play units – add accessories in minutes!



**DRAWER COMPONENT SHELVES**

- Create customized shelving modules with drawer component shelves.
- Built to bolt onto the DC6 and DC12, these shelves can provide additional storage space.
- The shelves are available in 18", 24" and 36" wide configurations.
- Feature a 1" shelf lip.

| MODEL     | DESCRIPTION       | SHELF SIZE  |
|-----------|-------------------|-------------|
| SF11218DC | 18" wide DC Shelf | 12"D x 18"W |
| SF11224DC | 24" wide DC Shelf | 12"D x 24"W |
| SF11236DC | 36" wide DC Shelf | 12"D x 36"W |

**ACCESSORIES**

| MODEL  | DESCRIPTION                           |
|--------|---------------------------------------|
| DV44U1 | Top shelf divider (single)            |
| DV44U4 | Top shelf divider kit (4 pack)        |
| DV44U  | Top shelf divider kit (8 pack)        |
| DV44L1 | Lower shelf divider (single)          |
| DV44L4 | Lower shelf divider (4 pack)          |
| DK532  | Door kit for 44 series shelving, 4432 |
| DK544  | Door kit for 44 series shelving, 4442 |
| DK550  | Door kit for 44 series shelving, 4450 |
| 28     | Plastic Blue Bin                      |

**STORAGE MODULES ARE USEFUL COMBINATIONS OF SHELVING AND STORAGE.**

When you need a variety of parts and tools to do the job, it is essential that you have them organized and easily accessible. Offering a variety of storage and workbench combinations, Adrian Steel Modules are the key to efficiency when working out of your van.

**MD507  
DRAWER RACK  
MODULE**

**MD507 INCLUDES:**

|    |                          |
|----|--------------------------|
| 9  | Four Drawer Shallow      |
| 18 | Utility Shelf            |
| 19 | Two Drawer Medium        |
| 40 | Wheelwell Cover Cabinet  |
| 43 | Three Shelf Catalog File |

**42"W x 46.5"H x 14"D**



**MD506  
DRAWER CABINET  
MODULE**

**MD506 INCLUDES:**

|    |                          |
|----|--------------------------|
| 9  | Four Drawer Shallow      |
| 12 | Shelf Cabinet (2)        |
| 19 | Two Drawer Medium        |
| 40 | Wheelwell Cover Cabinet  |
| 43 | Three Shelf Catalog File |

**42"W x 46.5"H x 14"D**



**MD534  
DRAWER RACK  
BIN MODULE**

**MD534 INCLUDES:**

|      |                          |
|------|--------------------------|
| 9    | Four Drawer Shallow      |
| 12   | Shelf Cabinet (2)        |
| 19   | Two Drawer Medium        |
| 33WB | Shelf Rack w/Bins        |
| 40   | Wheelwell Cover Cabinet  |
| 43   | Three Shelf Catalog File |

**52"W x 46.5"H x 14"D**



**MD508  
WORKBENCH MODULE**

**MD508 INCLUDES:**

|    |                         |
|----|-------------------------|
| 9  | Four Drawer Shallow     |
| 19 | Two Drawer Medium       |
| 40 | Wheelwell Cover Cabinet |
| 54 | Workbench               |

**42"W x 26"H x 14/18"D**



**MD509  
WORKBENCH MODULE**

**MD509 INCLUDES:**

|     |                         |
|-----|-------------------------|
| 8   | Three Drawer Medium (2) |
| 40  | Wheelwell Cover Cabinet |
| 54  | Workbench               |
| CB2 | Two Book File           |

**42"W x 31"H x 14/18"D**



**WORKBENCH MODULE  
FOR LOW, MEDIUM & HIGH ROOF**

The MD608 Workbench Module features 84" of work top surface perfect for any mobile workshop. Shown with optional 17A Catalog File and floor Rail Kit. See package 5274TL.

**MD608 INCLUDES:**

|       |                         |
|-------|-------------------------|
| KMB36 | 36" Key Machine Base    |
| 54    | Workbench (2)           |
| 9     | Four Drawer Shallow (2) |
| 19    | Two Drawer Medium (2)   |
| 40    | Wheelwell Cover Cabinet |
| 14    | Step Stool              |

Storage Modules are designed to fit over wheelwells of GM full size vans.

Visit [AdrianSteel.com](http://AdrianSteel.com) to see more Storage Modules.

**SPECIFIC JOBS DEMAND SPECIFIC STORAGE SOLUTIONS.**

Cabinet and Drawer Modules provide secure storage for large and small tools and parts. The modular design allows you to get what you need now and the ability to add more when you need it. Whatever the job demands, Adrian has the storage solutions to transport your gear safely and securely.



**TA20**  
**Vented gas storage solutions**

**TANK CABINETS**

- Provide vented storage for Propane, Mapp gas or CO2 tanks.
- Cabinets feature a full door gasket with two snap latches for positive door closure.
- Interior cabinet cradle and retaining straps (foam yokes for TA19) secure tanks and prevent movement.
- Floor vent and tubing are included for exhausting fumes.
- Propane cabinets store 20, 30 or 40 lb. tanks.
- Mapp Gas Cabinets store 6 1/2" diameter tanks.
- CO2 Tank Cabinets store 20 lb. cylinders.

| MODEL | DESCRIPTION      | CABINET SIZE           |
|-------|------------------|------------------------|
| TA18  | Propane Cabinet  | 14-3/4"W x 36"H x 13"D |
| TA19  | CO2 Tank Cabinet | 13"W x 32"H x 12-1/2"D |
| TA20  | Mapp Gas Cabinet | 14"W x 26"H x 8"D      |



**Folding T handles don't stick out into aisles.**

**SHELF CABINETS**

- Available in 12" and 18" front to rear lengths
- Can be used free standing or stacked with our lockable drawer units.
- Feature locking recessed tee-handles for secure storage and receive a durable gray powder coat finish.
- Cabinets feature an open side and can be combined for side-by-side use holding items up to 35" long.
- Optional end panel can be added to close off side when required.
- Include an adjustable shelf that can be removed
- Cabinets provide a solid surface to stack modular drawers, cabinets and bins.

| MODEL | DESCRIPTION             | CABINET SIZE       |
|-------|-------------------------|--------------------|
| 1     | Shelf Cabinet           | 18"W x 22"H x 18"L |
| 12    | Shelf Cabinet Open Side | 18"W x 22"H x 12"L |
| 1A    | Optional Shelf          | No. 1              |
| 12A   | Optional End Panel      | No.12              |



**40**

**40 WHEEL WELL COVER CABINET**

- Wheel well cover cabinets are designed with an open back and bottom.
- Serves as an enclosure for rear wheel wells.
- Provides a solid surface to stack modular drawers, cabinets and bins.
- Cabinets come with locking recessed tee-handles for secure storage.
- Finished with a durable gray powder coat finish.
- Cabinet size 42"W x 12.5"H x 14"L



**CL1446D**

**CL1446R**

**CABINET LOCKERS**

- Full-door Lockers feature a 46" high storage space with 3 removable shelves.
- Short-door Lockers feature a 33" high storage area and with 2 removable shelves.
- Locker doors are reversible for flexibility and feature locked recessed T-handles for security.
- Cabinet Lockers taper from 14" to 12" from front to back in depth at top and bottom to maximize aisle space.

| MODEL   | DESCRIPTION               | CABINET SIZE       |
|---------|---------------------------|--------------------|
| CL1446R | Cabinet Locker Full Door  | 18"W x 46"H x 14"D |
| CL1446D | Cabinet Locker Short Door | 18"W x 46"H x 14"D |



2.5" deep drawers come with ABS divided and removable trays perfect for small parts.

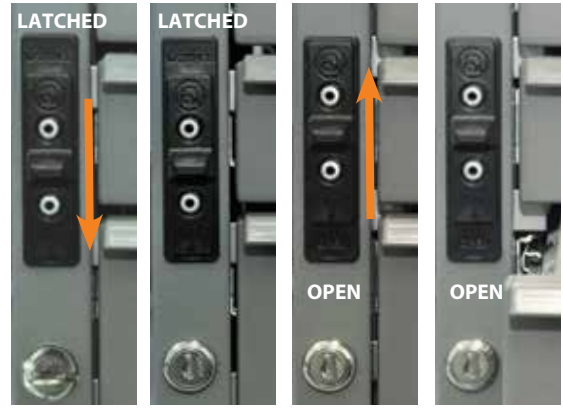

Latched & Locked    Latched & Unlocked    Drawers Unlatched    Drawers Open

### DRAWER UNITS – LOCK 'N LATCH SYSTEM

- Our exclusive Lock 'n Latch system provides a choice of drawers open, drawers retained or drawers locked position.
- Drawers are made of an engineered composite material for durability with heavy-duty drawer glides for support and smoother drawer operation.
- The new drawer glides significantly increase the ease of use when opening and closing the drawer units. They all but eliminate the rattle noise of the drawers when the driving the vehicle.
- Drawers and glides can be repositioned within cabinet for increased flexibility.
- Divide 5" deep drawers into compartments using optional metal "egg crate" dividers.

| MODEL | DESCRIPTION      | DRAWER SIZE (QTY.)   |
|-------|------------------|--|
| 19    | 2 Drawer Medium  | 16"W x 5"D x 11-1/2"L (2)                                  |
| 919   | 3 Drawer Combo   | 16"W x 2-1/2"D x 11-1/2"L (2)<br>16"W x 5"D x 11-1/2"L (1) |
| 9     | 4 Drawer Shallow | 16"W x 2-1/2"D x 11-1/2"L (4)                              |
| 27    | Divider Kit      | 19 or 919 Drawer (1)                                       |

Steel outer cabinet measures 18"W x 12"H x 12"L.

### DRAWER COMPONENTS

- Organize small parts with our flexible and rugged composite Drawer Components.
- Drawer retention stops prevent drawers from opening while the vehicle is in transit.
- Made of a hi-impact polymer for a quiet operation.
- Each drawer comes with 2 dividers and 7 divider slots.
- Interlocking feature allows up to 2 units stacked vertically or multiple units horizontally.
- Choose from Adrian Steel's pre-configured drawer systems or create your own drawer system from the base models.

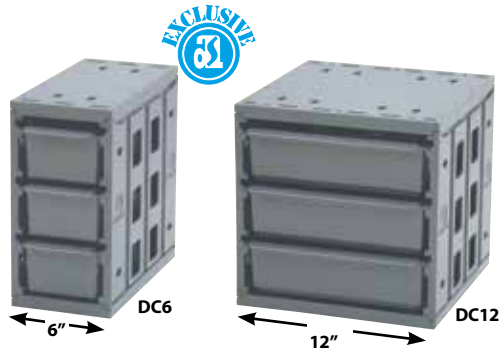

| MODEL    | DESCRIPTION                | OVERALL SIZE       |
|----------|----------------------------|--------------------|
| DC6      | Base 3 drawer narrow model | 6"W x 12"H x 12"D  |
| DC12     | Base 3 drawer wide model   | 12"W x 12"H x 12"D |
| DS06212V | Drawer System (2) DC12's   | 12"W x 24"H x 12"D |
| DS36012H | Drawer System (3) DC6's    | 18"W x 12"H x 12"D |
| DS46012  | Drawer System (4) DC6's    | 12"W x 24"H x 12"D |

5lb. weight capacity per drawer.

#2 Cabinet Size  
18"W x 24"H x 18"L

#8 Cabinet Size  
18"W x 18"H x 12"L



### DRAWER UNITS – LOCKING HINGE AND HASP

- Drawers are welded and have reinforced drawer slides for strength.
- Can be locked with a padlock (not included) for security.
- Divide drawers with optional metal "egg crate" dividers.

| MODEL | DESCRIPTION     | DRAWER SIZE (QTY.)        |
|-------|-----------------|---------------------------|
| 8     | 3 Drawer Medium | 16"W x 5"D x 11-1/2"L (3) |
| 2     | 4 Drawer Medium | 16"W x 5"D x 17-1/2"L (4) |
| 25    | Divider Kit     | No. 2 Drawer (1)          |
| 26    | Divider Kit     | No. 8 Drawer (1)          |

### TOTE TRAYS AND CASES

- Take small parts and tools right to the job site with removable tote trays and cases.
- Totes are available in both steel tray and poly case designs.
- Steel tote trays feature fold-down carry handles and four large storage compartments with adjustable dividers.
- Poly tote cases offer a see-through lid with latches to prevent spilling, four large compartments and twelve adjustable dividers.
- Trays and cases store in a 19.75"W x 20-1/8"H x 13-3/8"L modular rack that can be stacked or floor mounted.



| MODEL  | DESCRIPTION           | TOTE STYLE (QTY.)              |
|--------|-----------------------|--------------------------------|
| SPT-4  | Combo Totes and Rack  | Steel Trays (2) Poly Cases (2) |
| SPT-4P | Poly Totes and Rack   | Poly Cases (4)                 |
| SPT-4S | Steel Totes and Rack  | Steel Trays (4)                |
| SPT-S  | Additional Steel Tray | 18.5"W x 3"D x 12.5"L          |
| SPT-P  | Additional Poly Tote  | 18.5"W x 3"D x 12.5"L          |

Portable trays

**BE MORE EFFICIENT WITH INVENTORY THAT IS READY TO GO WHEN AND WHERE YOU ARE.**

Versatile, lightweight, durable, convenient and mobile - these **Portable Parts Cases** are perfect for the tech who needs to carry small parts and inventory to the jobsite.

The impact resistant body can be organized with the included adjustable dividers. The see-through lids with snap latches make identifying contents easy.

**PPCS** 14" x 14" x 3.75"  
**PPCL** 14" x 14" x 6.25"

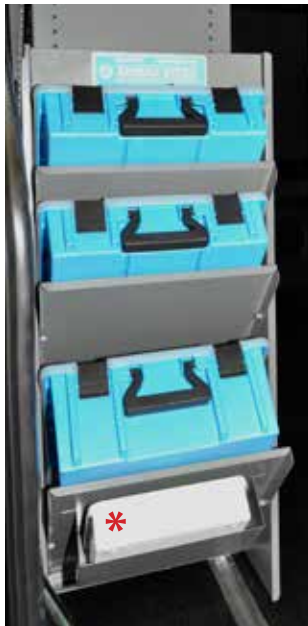
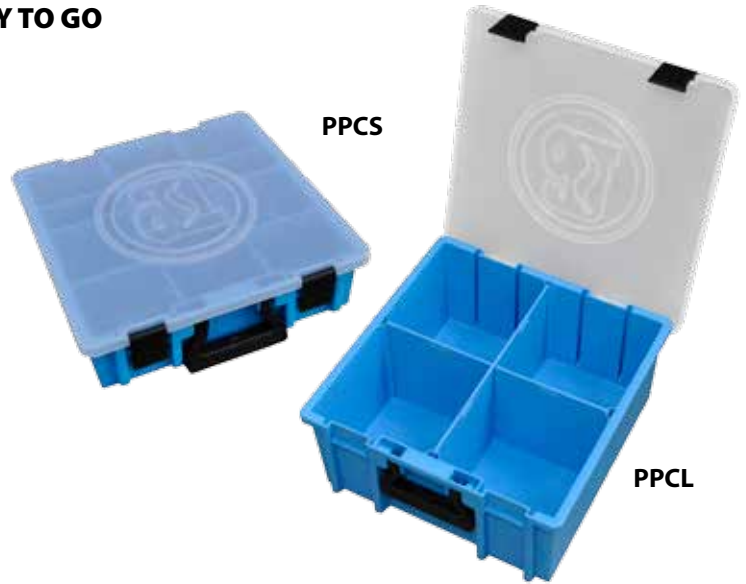

**CH-EP**

\* FIRST AID KIT NOT INCLUDED



**CHPPC5SM**



Add a single **CH1514SGL** or double **CH-1514DBL Case Holder** to an existing shelf to house included cases that stay put while in transport.

**INCORPORATE THE PORTABLE PARTS CASES INTO YOUR VAN WITH THE STORAGE OPTION THAT FITS YOUR NEED.**

Three different **Case Holder** options give you the ability to house multiple Portable Parts Cases near the vehicle door for easy access to grab-and-go. The **CH-EP** and **CHPPC5SM** include a tray that holds an optional first aid kit and feature slanted shelves.

The **CHPPC4S** includes four PPCS cases and each shelf has a retaining lip to keep cases in place.



**CHPPC4S**

**KEEP WORK ORDERS AND INVOICES ORGANIZED AND SECURE WITH ADRIAN'S STORAGE FILES.**



**Center Console Desk**

- Designed to mount between the front seats.
- Rugged steel construction with a hinged worktop and key locking paddle handle.
- Convenient lid mounted clip holds papers in place on the writing surface.
- Center Console Desks mount securely to the vehicle floor, and can be removed for service.
- Convenient access to add a power strip. Great for storing electronics out of sight.
- Measures 12.2" x 22.4" x 18.4".



**CCD12 Center Console Desk for Express/Savana**

**CCDLTH Optional Laptop Holder**

**CCDHF12 Optional 12" Hanging File Holder**

**Aluminum Lock Box**

- Stores valuable tools and paperwork.
- Gas shock safely opens and closes the large lid.
- The large lock will accommodate a padlock or hockey puck style lock (not included.)
- Designed to mount on the van floor facing out the side or rear doors.
- Aluminum construction with powder coat black paint.



**LKB1 Aluminum Lock Box**  
20" W, 14.5" H, 25" D



**Literature Files**

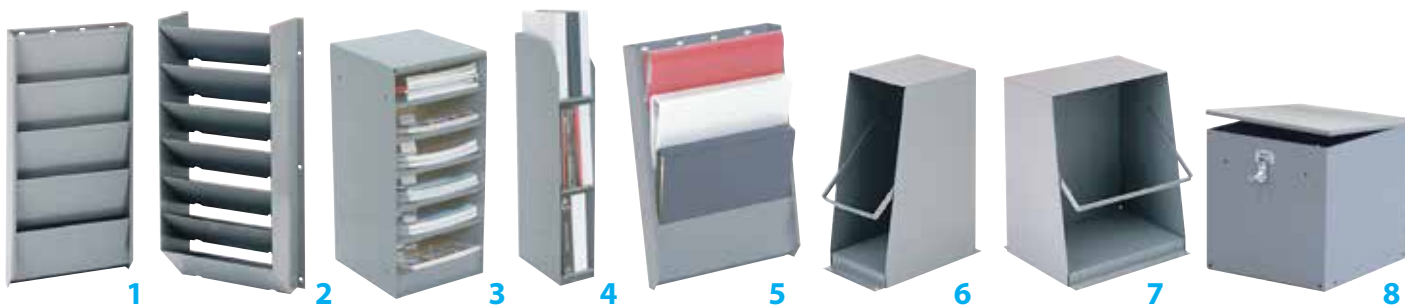

**1: CB5 Five Slot Literature Holder** Mount on partition or other vertical surface. 2-1/2" deep pockets. Overall size: 12"W, 24"H, 2-1/2"D.

**2: CB7 Seven Slot Literature Holder** Mount on partition or other vertical surface. 6-3/4" deep pockets. Overall size: 14-3/4"W, 28-7/8"H, 7"D.

**3: 17A Six Shelf Catalog File** Designed for catalogs but also serves to store a variety of materials between the 3" shelf spacings. Overall size: 11"W, 24"H, 12"D.

**4: 43 Three Shelf Catalog File** Fits in narrow spaces. It has three tilted shelves. Perfect for binders and catalogs. Overall size: 6" W, 34" H, 12" D.

**5: BH4 Four Slot Binder Holder** Designed to mount on partition or almost any vertical surface. Excellent for binders. Each pocket is 2 1/2" deep. Overall size: 12-3/4" W, 19-1/2" H, 2-1/2" D.

**6: CB2 Two Book File** Mounts on the floor between front seats and partition. Holds folders 12"H x 10-1/2"D. Overall size: 6"W, 14"H, 12"D.

**7: CB3 Three Book File** Mounts on cabinet tops or on the floor. Multiple units can be flush-mounted. Holds folders 12"H x 10-1/2"D. Overall size: 10-3/4"W, 14"H, 12"D.

**8: CB4 Utility Storage Box** Stores a variety of printed material. Also suitable for keeping tools, safety glasses, gloves and other items. Hinged lid. Overall size: 12"W, 12"H, 14"D.



**ADRIAN'S STOW-ALL IS THE FINEST FLOOR STORAGE UNIT YOU CAN BUY.**

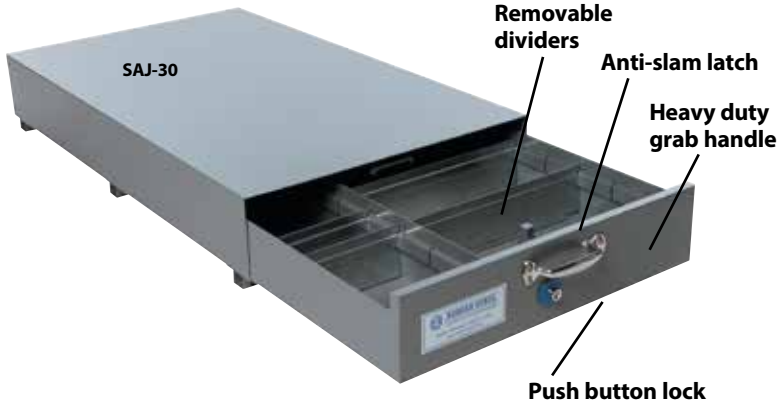

- 14 Gauge steel outer cabinets are constructed with top channel cross support members for strength and rigidity.
- Drawers are constructed with double sidewalls to prevent bowing and to accommodate items up to 48" in length.
- The anti-slam latch stops drawers from completely closing without positive latch activation.
- Heavy-duty grab handle and push button lock allows for comfortable, one-handed drawer operation.
- Durable powder coat finish will provide years of rugged service.
- Easy glide drawers with full width recessed conveyor roller at front and hardened steel roller bearings at rear.
- Install at rear or side doors, and units can be stacked.



SA-10



SA-20



SA-40

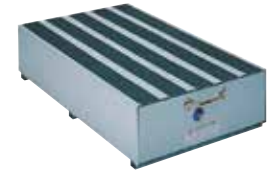

**STOW-ALL DEEP SERIES**

| MODEL | DESCRIPTION      | CABINET SIZE           | DRAWER SIZE   | TRACTION KIT | DIVIDER (QTY.)     |
|-------|------------------|------------------------|---|--------------|--------------------|
| SA-10 | Single Wide Deep | 10"W x 12"H x 51-1/2"D | 9-5/8"W x 8-1/2"H x 48-1/2"D                                      | TK10         | DV9(5)             |
| SA-20 | Double Wide Deep | 20"W x 12"H x 51-1/2"D | 19-5/8"W x 8-1/2"H x 48-1/2"D                                     | TK20         | DV19(5)            |
| SA-40 | Full Wide Deep   | 40"W x 12"H x 51-1/2"D | 9-5/8"W x 8-1/2"H x 48-1/2"D (2)<br>19-5/8"W x 8-1/2"H x 48-1/2"D | TK40         | DV9(10)<br>DV19(5) |

**Traction Kits** are available to provide a positive friction surface for better footing. Traction Kits are 4" wide, self-adhesive strips.



SAJ-10



SAJ-20



SAJ-30



SAJ-40

**Additional Dividers** are available and are sold individually.

**STOW-ALL SHALLOW SERIES** Stow-All quality in a lower profile

| MODEL  | DESCRIPTION         | CABINET SIZE              | DRAWER SIZE   | TRACTION KIT | DIVIDER (QTY.) |
|--------|---------------------|---------------------------|---|--------------|----------------|
| SAJ-10 | Single Wide Shallow | 10"W x 8-1/2"H x 51-1/2"D | 9-5/8"W x 5-1/4"H x 48-1/2"D                                  | TK10         | DVJ9(5)        |
| SAJ-20 | Double Wide Shallow | 20"W x 8-1/2"H x 51-1/2"D | 19-5/8"W x 5-1/4"H x 48-1/2"D                                 | TK20         | DVJ19(5)       |
| SAJ-30 | Triple Wide Shallow | 30"W x 8-1/2"H x 51-1/2"D | 9-5/8"W x 5-1/4"H x 48-1/2"D<br>19-5/8"W x 5-1/4"H x 48-1/2"D | TK30         | DVJ9(5)        |
| SAJ-40 | Full Wide Shallow   | 40"W x 8-1/2"H x 51-1/2"D | 9-5/8"W x 5-1/4"H x 48-1/2"D (2)                              | TK40         | DVJ9(10)       |

**ALUMINUM FLOOR DRAWERS**

- Adrian Steel exclusive Anti-Slam latch keeps drawer from closing without positive latch activation. The only aluminum drawer in the industry with this feature!
- An automotive grade lock keeps expensive cargo secure and the adjustable divider helps keep contents segmented.
- The integral latch keeps the drawer open when you are on an incline and closed when you're done!
- Heavy duty grab handles and ball bearing slides allow the drawer to open and close with ease.
- Can be stacked to utilize large cubic storage areas.
- 24" deep units have a weight capacity of 350 lbs. and the 36" deep have a 325 lb. weight capacity.

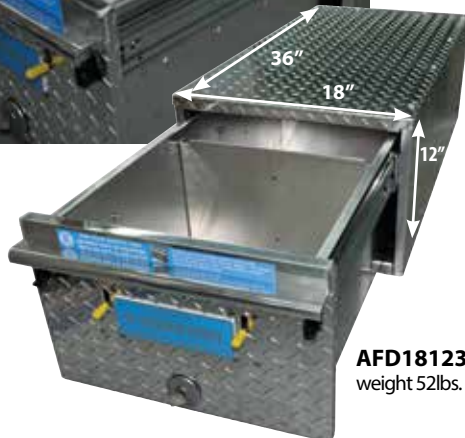
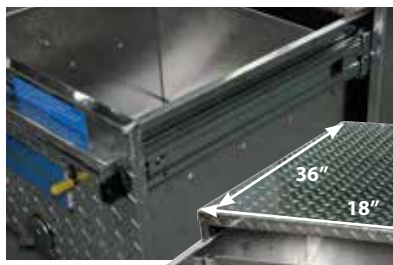

**AFD181236**  
weight 52lbs.

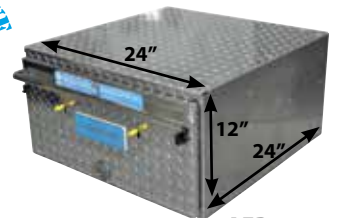

**AFD241224**  
weight 46lbs.

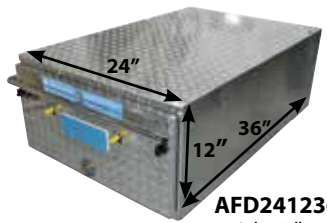

**AFD241236**  
weight 60lbs.

**ADRIAN'S BLUE BIN SYSTEM IS PERFECT FOR VISUAL INVENTORY MANAGEMENT.**

- 6" and 12" bins maximize the ADseries shelf space.
- The innovative rail system locks the bins in place on the shelf.
- The bins can nest on top of each other when at the job site or in the warehouse getting filled to go.
- Add a label to the front so you can find parts quickly
- Each bin can accommodate one optional divider.

**Order our predefined bin systems or create your own configuration of bins. Please note that the bins and the rail are a system. To obtain all the features listed above, both must be ordered.**



**SBIN120614**



**SBIN060614**



**BR36212 Bin System on an AD44FP ADseries shelf unit.**



**Bins lock into place along the rail for secure transport.**

| MODEL      | DESCRIPTION                          |
|------------|--------------------------------------|
| SBIN060614 | 6" Blue Bin                          |
| SBIN120614 | 12" Blue Bin                         |
| SBINDIV    | Divider                              |
| BR36212    | Bin System: 3-6" & 2-12" bins w/rail |
| BR76012    | Bin System: 7-6" bins with rail      |
| SRAILAD26  | 26" Retention rail                   |
| SRAILAD32  | 23" Retention rail                   |
| SRAILAD44  | 44" Retention rail                   |
| SRAILAD50  | 50" Retention rail                   |

**PROTECT YOUR VAN AND CARGO WITH ADRIAN STEEL FLOOR MATS.**

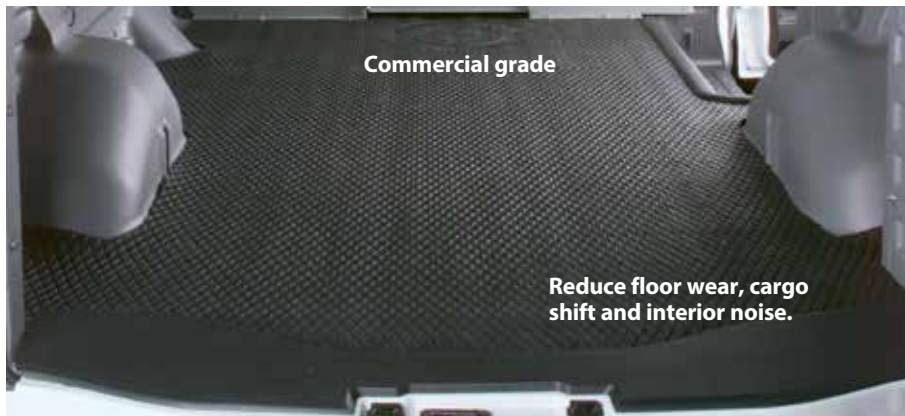

**Commercial grade**

**Reduce floor wear, cargo shift and interior noise.**

**Floor Mats** are die-cut for wheelwells and meet flammability test MVSS 302. Made of 3/16" rubber, diamond corrugated pattern. Side stepwell and seat pedestals require some trimming.

- 88-2** GM Full Size LWB Vans
- 88-9** GM Full Size XLWB Vans

**SAFELY TRANSPORT REFRIGERANT TANKS IN AN ADRIAN STEEL TANK RACK.**



Vertically carry 30-lb. and 50-lb. refrigerant tanks securely in your van. Tank Racks can be installed for easy access from the side or rear van doors. Racks feature 14-gauge tubular steel frames welded for strength with sloped cradles and nylon straps. The optional **WTRTRAY** provides a storage area mounted on top of the welded tank racks.\* The tray can be mounted to any size tubular tank rack.

| MODEL     | DESCRIPTION                 |
|-----------|-----------------------------|
| WTR130250 | (1) 30 lb & (2) 50 lb tanks |
| WTR230150 | (2) 30 lb & (1) 50 lb tanks |
| WTR330    | (3) 30 lb tanks             |
| WTR350    | (3) 50 lb tanks             |
| WTR430    | (4) 30 lb tanks             |
| WTRTRAY   | Top Tray                    |



\*Please confirm the location of the tank rack and tray, some interior locations will not accommodate the tray due to the contour of the vehicle.



1



2



3



4

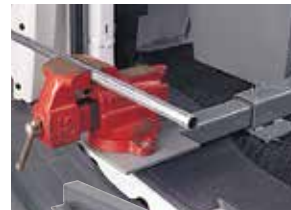

5

**1: DST21 Door Storage Tray** offers convenient access to parts and tools.  
Overall size: 20" W, 4" D, 8" H

**2: Aerosol Can Tray** secure cans for easy access.

**ACT3** - 3 Can Tray Overall size: 11-3/4" W, 4" D, 6-3/4" H

**ACT4** - 4 Can Tray Overall size: 15-7/16" W, 4" D, 6-3/4" H

**3: 14 Step Stool** has a wide base and is 12" high. Stool can be used with a workbench or as an auxiliary step. Top measures 10" x 20" One size.

**4: TA2 Hard Hat Holder** secures hat to partition or shelving.

**5: VMA36 Vise Mount Assembly** is floor mounted and telescopes out beyond side or rear cargo doors when fully opened. Measures 36" closed and 60" open.

**6: Touch-Up Paint** in spray cans match Steel-Cote™ finish. Three colors:

**STP12G** - Gray **STP12W** - White **STP12B** - Black

**7: Door Tray** comes with two dividers and has optional lid for containment.

**DT21** - Door Tray Overall size: 18" W, 4" D, 4" H

**DTL21** - Door Tray Lid for DT21 only

**DTWL21** - Door Tray with Lid Overall size: 20" W, 4" D, 4" H

**8: Hooks** organize a variety of cargo in easy-to-access locations.

**UH10** - 1" hook

**UH25** - 2.5" hook

**UH50** - 5" hook

**TA1** - Four hook bar

**9: Parts Tray** features a 2" deep shelf lip. Can be mounted to cabinet and drawer modules for added top storage.

**4A** - Parts Tray Overall size: 36" W, 12" D, 2" H

**4B** - Parts Tray Overall size: 18" W, 12" D, 2" H



6



Storage for small parts 7



8

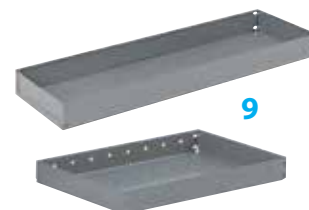

9

**REEL HOLDERS**



1



2



3



4

**1: CRH2 Cable Reel Holder** features a durable frame, two steel shafts that holds up to a 15-1/2" diameter reel by 14" wide. Overall size: 19-1/8" W, 16" D, 44-7/8" H

**2: KDRH2 Cable Reel Holder** holds large spools up to 16" wide and 18" in diameter. Spools nest on conveyor rollers. Includes tie-down chains with neoprene covers. Overall size: 18" W, 46" H, 18" D

**3: WRH5 Wire Reel Holder** Five removable bars hold wire spools up to 6" in diameter. Reel Holder mounts to shelf ends or any vertical surface. Overall size: 12" W, 25" H, 4" D

**4: End Panel Reel Holder** Bar mounts between ADseries shelf end panels for easy access to spools of cable and wire.

**KDRH1426** - fits 26" shelf **KDRH1432** - fits 32" shelf  
**KDRH1444** - fits 44" shelf **KDRH1450** - fits 50" shelf

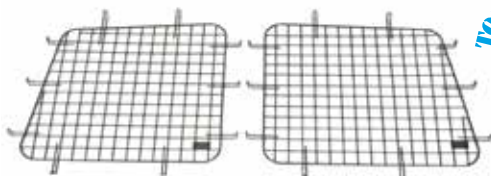



**Wire Window Screens** add security to cargo area windows.

**60-25 & 60-26** GM Full Size Van Curb Sliding Door  
**60-21 & 60-22** GM Full Size Van Curb Hinged Door  
**60-23 & 60-24** GM Full Size Van Rear Hinged Door  
**60-NV2** City Express Rear Door Kit  
**60-120** City Express Streetside Rear Door  
**60-121** City Express Curbside Rear Door

### LOADING LADDERS JUST GOT DOWN RIGHT EASY.

Adrian's LOADSRITE Ladder Racks easily raise and lower to eliminate the need to climb, stretch or reach for your ladder on top or your van. The unique design of the LOADSRITE presents the ladder in a diagonal position bringing it to a comfortable working height in the right way. LOADSRITE, the right way to load and unload ladders.



1. Easy Reach Handle



2. Glide-Out Bed Platform



3. Hydraulic Load Assist



4. Ladder Pivot Pad

**Easier to Use!  
Lower Handle!  
Less Adjusting!**

### FEATURES & BENEFITS

- Aluminum bed frame, cast aluminum grab handle, stainless steel latch and all stainless steel fasteners.
- Allows side and rear door access while in the up or down position.
- Ladders can be padlocked for security.
- Hydraulic speed damper gently lowers ladder bed.
- Steel-Cote™ diamond-hard powder coat finish-for quality.
- Easy operation from the side of the vehicle.
- There are no straps to deal with, clamping of ladder is automatic.
- Rear bed lowers to present ladder at a convenient position.
- The Loads Rite cross supports measure 84" front to back and 70" side to side.

Note: Loadsrите is not compatible with GM Pro/Access Van.

Note: Carries 7 to 36 foot extension ladders and 7 to 8 foot step ladders.  
Carry 6'-12' step ladders with optional step ladder kit LRSLK612.

| MODEL             | DESCRIPTION                                     |
|-------------------|---|
| EXPRESS/SAVANA    |   |
| LR6100WCF or WSF* | Single Loadsrите Ladder Rack                    |
| LR6200WCF or WSF* | Single Loadsrите Add-on Kit for Grip-Lock Racks |
| LR6300WF          | Double Loadsrите Ladder Rack                    |
| LR6400WCF or WSF* | Combo Loadsrите Ladder Rack                     |
| LRSLK612          | 6'-12' Step Ladder Kit                          |

\*Note: Loadsrите is ordered preconfigured for the street-side or curbside.

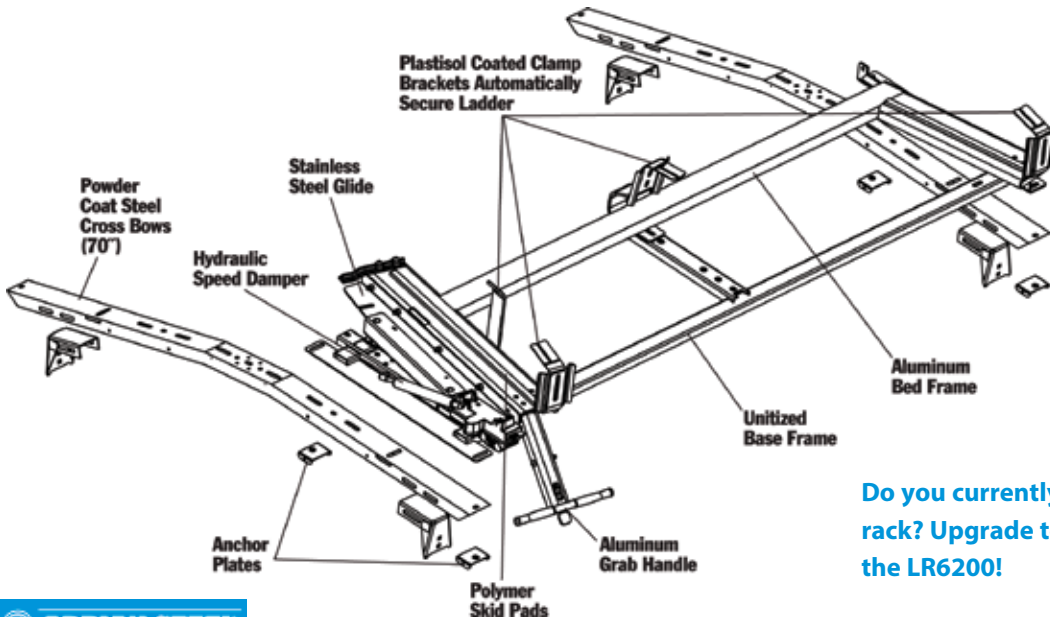

**LOADSRITE  
KEEPS  
LOADING AND  
UNLOADING  
FROM BEING  
A PAIN IN THE  
BACK.**

Do you currently have a Grip Lock ladder rack? Upgrade to the LOADSRITE easily with the LR6200!



Add padlock for security

Adjustable ladder stops securely grip ladder rungs.

**SHOWN:**  
61-1 Grip Lock ladder rack with LR6200WSF LoadsRite ladder rack add-on kit.

### SECURELY TRANSPORT YOUR LADDERS WITH A GRIP-LOCK RACK.

Adrian's Grip-Lock racks protect the sides and roof of your van during loading and unloading ladders. All Grip-Lock racks feature a lockable, gripping mechanism which firmly secures one or two ladders to the top of the van. Racks easily adjust for ladders of different sizes.

### FEATURES & BENEFITS

- Heavy-Duty actuating arm firmly grips ladder rungs to prevent shifting of ladder on rack.
- Gripping mechanism is lockable with an optional padlock.
- Rung grips easily adjust to accommodate different types of ladders.
- The full size van racks are finished in a diamond-hard powder coat paint. Key structural members receive durable undercoat of galvanneal plating for weather protection and corrosion resistance. Polymer adhesive pads protect the ladder from contact damage.
- The City Express rack features an all aluminum design with a natural finish. Composite extrusions on the crossbars and uprights protect ladders.
- Mounts to drip-rails on full-size vans for easy installation.
- Mounts to pre-existing mounting points in roof of City Express. No drilling required.

**SERIES 61** Single Grip-Lock rack provides lock-down mechanism for one ladder.

**SERIES 63** Double Grip-Lock rack provides lock-down mechanism for two ladders. All Grip-Lock ladder racks feature heavy-duty handle latch for security.

**SERIES 64** Combo Ladder rack combines the features of a 24" ladder rack extension for longer ladders with the stepladder support kit on the Double Grip-Lock ladder rack.

### GRIP-LOCK LADDER RACK FOR CITY EXPRESS



**SHOWN:**  
63-NV2 Double Grip-Lock on a City Express.

The **City Express Grip-Lock Rack** features an all aluminum design with a natural finish for the best in quality and longevity. The Grip-Lock mounts directly to pre-existing mounting points in the City Express roof, no drilling is required for installation. Available in single and double configurations.

**Tip:** Adjusting the clamp brackets for your ladder is important to keep the ladder safe and secure.



SHOWN: 61-1 Grip Lock ladder rack with LR6200WSF LoadsRite ladder rack add-on kit.

| STYLE                 | MODEL  | DESCRIPTION   |
|-----------------------|--------|---|
| <b>EXPRESS/SAVANA</b> |        |   |
| SERIES 61             | 61-1   | Single Lock-Down  |
| SERIES 63             | 63-1   | Double Lock-Down  |
| SERIES 64             | 64-1   | COMBO Double Lock-Down<br>includes 69-4 extension kit and 68-3 ladder support kit |
| <b>CITY EXPRESS</b>   |        |   |
| SERIES 61             | 61-NV2 | Single Grip-Lock Rack   |
| SERIES 63             | 63-NV2 | Double Grip-Lock Rack   |
| <b>ACCESSORIES</b>    |        |   |
| Step Ladder Kit       | 68-3   | Auxiliary Ladder Support  |
| Extension Kit         | 69-4   | 24" Ladder Rack Extension   |
| Rail Cover Kit        | 76     | Protective cover for all ladder rack rail and horn                                |
| Conduit Carrier       | 80-1   | 10' 6" Aluminum Conduit Carrier   |
| Conduit Carrier       | 80-2   | 12' 6" Aluminum Conduit Carrier   |
| Conduit Carrier       | 70-1   | 4" Diameter PVC Conduit Carrier Kit (use with 4.5" OD PVC)                        |
| Conduit Carrier       | 70-2   | 6" Diameter PVC Conduit Carrier Kit (use with 6-5/8" OD PVC)                      |

## Grip-Lock Rack Accessories

### Express / Savana / City Express

**CUSTOMIZE YOUR GRIP LOCK LADDER RACK FOR YOUR LADDER CARRYING NEEDS.**



69-4



76

**69-4 Extension Kits** Ladder rack extension kits add 24" to overall length for longer ladders. Kit includes plastisol side rails and cross support with two polymer ladder pads.

**68-3 Step Ladder Support Kits** Carry step ladders shorter than the distance between the front and rear cross supports. Kit includes one polymer adhesive-back ladder pad.

**76 Rail Cover Kit** Protect your fiberglass ladders from wear. Kit includes covers for ladder rack horn and rail to protect ladder from contact damage.

**80-1, 80-2 Aluminum Conduit Carriers** feature a lift-up door for easy access and lockable swivel closure for security.

**70-1, 70-2 PVC Conduit Carrier Kit** (not shown) includes cast aluminum hinged lid and end cap, two stainless steel U-bolts, sealant and fasteners. Use with PVC pipe schedule 40 (not supplied.)



68-3

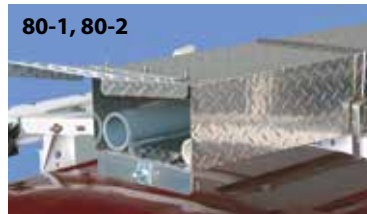

80-1, 80-2



Aluminum Conduit Carrier

**2B STEEL UTILITY RACK FOR EXPRESS/SAVANA**

- The new design has eliminated much of the welding. This feature **reduces corrosion up to 80% more compared to similar goal-post style racks!**
- The uprights are fully plastisol to protect against wear and reduce ladder fatigue.
- Uprights feature a number of attachment points for securing cargo straps.
- Designed to fit GM Express and Savana full size vans.
- Weather resistant cross bar is not cut to fit or perforated in any way improving longevity of the rack.
- Available in our durable black or white powder coat paint.
- Optional center bar supports shorter lengths and provides center support.

| MODEL  | DESCRIPTION                                 |
|--------|---|
| 1BRS-B | Steel One Bar Mid Cross Beam Assembly/Black |
| 1BRS-W | Steel One Bar Mid Cross Beam Assembly/Black |
| 2BRS-B | Steel Two Bar Black                         |
| 2BRS-W | Steel Two Bar White                         |
| SSK-BS | Side Stop Kit Black                         |
| SSK-WS | Side Stop Kit White                         |



**2B ALUMINUM UTILITY RACK FOR EXPRESS/SAVANA**

- Extra wide mount foot and welded tie hooks
- No drilling or cutting required to install prevents exposing metal to the weather.
- Available in our durable black or white powder coat paint.
- Upright caps protect ladders when loading and unloading.
- Optional center bar supports shorter lengths and provides center support.
- Designed to fit GM Express and Savana full size vans.

| MODEL  | DESCRIPTION                                    |
|--------|--|
| 1BAR-B | Aluminum One Bar Mid Cross Beam Assembly/Black |
| 1BAR-W | Aluminum One Bar Mid Cross Beam Assembly/Black |
| 2BAR-B | Aluminum Two Bar Black                         |
| 2BAR-W | Aluminum Two Bar White                         |
| SSK-BA | Side Stop Kit Black                            |
| SSK-WA | Side Stop Kit White                            |

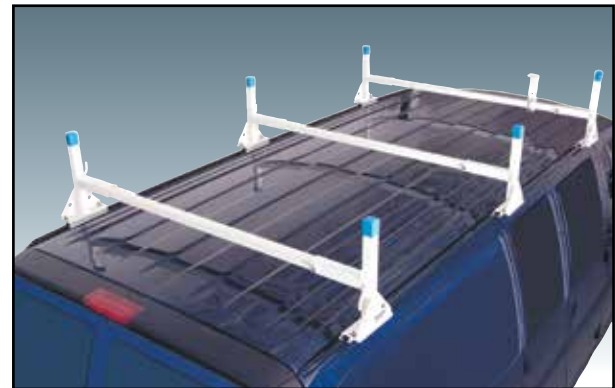

**ALUMINUM UTILITY RACK FOR CITY EXPRESS**

The most flexible rack in the market, the 2BNV2 features an all aluminum design that allows you to maximize the roof of the City Express. No drill installation and an innovative rail system allows the user to easily reposition the crossbows where they are needed. **2BNV2 - Aluminum Utility Rack for City Express**



### PERIMETER RACK FOR EXPRESS/SAVANA



| MODEL | DESCRIPTION                              |
|-------|--|
| VP1   | Perimeter Cargo Rack-fits Express/Savana |
| VPE1  | Rack Extension-fits VP1                  |
| CC17  | Center Cross Bar-fits VP1                |
| RR5   | Cargo Rack Roller-fits VP1               |

#### VAN ACCESSORIES

|       |                                |
|-------|--------------------------------|
| AS12  | Auxiliary Bumper Step          |
| BS6VP | Beacon/Stroke Light Stand      |
| LS3VP | Ladder Stop                    |
| RS4   | Ratchet Strap                  |
| SH12  | Step Handle                    |
| 80-1  | 10'6" Aluminum Conduit Carrier |
| 80-2  | 12'6" Aluminum Conduit Carrier |

#### PERIMETER RACKS

The VP1 Cargo Rack is designed to fit Express and Savana full size vans. Gutter mounted design requires no drilling. Crossmembers spaced from front bar are 52", 113" and 130" to slantdown rear bar.

- VPE1 Optional Rack Extension (for VP1 only)
- Extend front of rack 30" with additional crossmember for extended long wheel-base full-size vans only.

#### FEATURES & BENEFITS

- Maximize carrying capacity of van.
- Frame constructed from 2" x 1" 13 GA square tube.
- All racks include rope hooks for easy tie-down.
- Slantdown rear section eases loading.
- Powder coat paint finish for lasting protection.



**RR5 Cargo Rack Roller** makes all your cargo easy-on and easy-off. Fits VP1 only. Includes two U-bolts for mounting.



**RS4 Ratchet Strap** safely ties down cargo. Locking ratchet action handle with 7 x 1.5" strap. Fits VP1 only.

**BS6VP Beacon/Stroke Light Stand** raises light above rack for improved visibility.

**LS3VP Ladder Stop** provides rung stop and tie off point for ladders.

### STORING LADDERS INSIDE YOUR WORK VAN IS EASY AS 1, 2, 3, WITH OUR LADDER KEEPER.

Designed to be loaded from outside the vehicle, the Ladder Keeper features a spring-loaded clamp that holds the ladder securely in place. Just set the top of the ladder in the front clamp bracket and push it forward until the bottom of the ladder sits in the rear clamp bracket. Can be mounted to the ceiling or wall of the vehicle to keep ladders inside and out of the elements.



**1** Simply press ladder inward to release rear ladder rung from the rear clamp bracket.



**2** Walk the ladder back as the front clamp bracket glides on the track.



**3** Remove front rung from the front clamp bracket and you're ready to go to the job site!

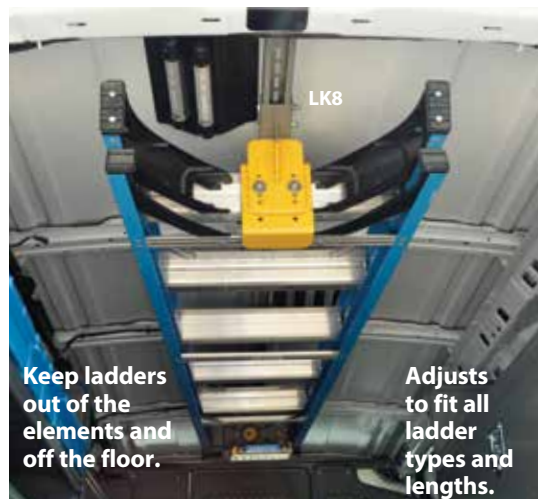

Keep ladders out of the elements and off the floor.

Adjusts to fit all ladder types and lengths.

**Ladder Keeper** includes all parts needed to carry up to a 6' ladder in a regular wheelbase van and an 8' ladder in a long wheelbase van. To accommodate larger vehicles or ladders, you will require the LKX extension that provides 4' of additional track.

**LK8** - Ladder Keeper for GM Express/Savana LWB  
**LKX** - Four foot Extension for GM Express/Savana XLWB



**STORAGE SOLUTIONS THAT STAND UP TO THE JOB.**

General Contractor packages feature flexibility with adjustable shelving and drop in dividers that can be configured for what you need today and adjusted for what you need down the road. Complete the package with a ladder or cargo rack, a driver data file to organize your paperwork, and a graphic to turn your vehicle into a billboard for your business.

**GENERAL SERVICE PACKAGE**  
**4317G GM FSV long wheelbase**  
**4317GX GM FSV x-long wheelbase**

| ITEM | MODEL     | DESCRIPTION             | QTY |
|------|-----------|-------------------------|-----|
| 1    | AD44FP    | ADseries 44" shelf unit | 3   |
| 2    | RKFSVLWB  | Rail Kit for AD series  | 1   |
| 3    | DV14C8    | Divider 8 pack          | 1   |
| 4    | 919       | Three Drawer Combo      | 1   |
| 5    | S1M2C2FSV | Partition               | 1   |
| 6    | UH50      | Utility Hook            | 2   |
| 7    | DK4208    | 8" Door Kit             | 2   |
| 8    | TA1       | Hook Bar                | 1   |
| 9    | 19        | Two Drawer Medium       | 1   |
| 10   | DC6       | Drawer Component - 6"   | 1   |
| 11   | BRK14EPS  | End Panel Bracket       | 2   |
| 12   | WKC2FSVGM | Partition Wing Kit      | 1   |



All Trade Packages include a steel cargo partition.

**2256G GENERAL CONTRACTOR PACKAGE**

**GM Full-Size Long Wheelbase Vans**

| ITEM | MODEL     | DESCRIPTION   | QTY |
|------|-----------|---|-----|
| 1    | DV14      | 14" Divider   | 14  |
| 2    | MD507     | Drawer Cabinet Rack Module  | 1   |
| 3    | TA1       | Hook Bar  | 1   |
| 4    | DK552     | Door Kit  | 1   |
| 5    | UH50      | Hook 5"   | 2   |
| 6    | HD-42FP   | HD Adjustable Closed End Shelving Overall Size: 46" H, 42" W, 14" D | 1   |
| 7    | HD-52FP   | HD Adjustable Closed End Shelving Overall Size: 46" H, 52" W, 14" D | 1   |
| 8    | S1M2C2FSV | Partition   | 1   |
| 9    | WKC2FSVGM | Partition Wing Kit  | 1   |

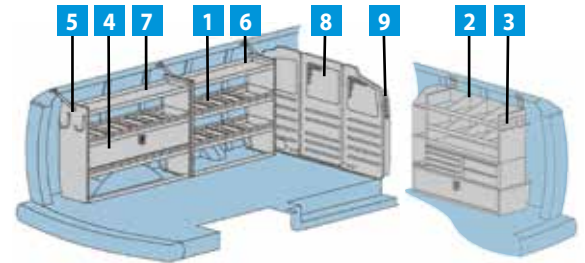

**2257G GENERAL CONTRACTOR PACKAGE**

**GM Full-Size Long Wheelbase Vans**

| ITEM | MODEL     | DESCRIPTION   | QTY |
|------|-----------|---|-----|
| 1    | 12        | Open Side Shelf Cabinet   | 1   |
| 2    | DV14      | 14" Divider   | 16  |
| 3    | 9         | Four Drawer Shallow   | 1   |
| 4    | 19        | Two Drawer Medium   | 1   |
| 5    | UH50      | Hook 5"   | 4   |
| 6    | HD-32FP   | HD Adjustable Closed End Shelving Overall size: 46" H, 32" W, 14" D | 1   |
| 7    | HD-42FP   | HD Adjustable Closed End Shelving Overall size: 46" H, 42" W, 14" D | 2   |
| 8    | S1M2C2FSV | Partition   | 1   |
| 9    | WKC2FSVGM | Partition Wing Kit  | 1   |

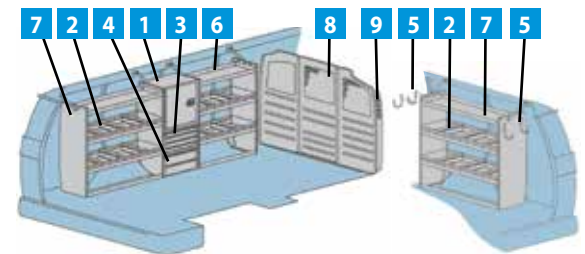

Graphic designed with:



More info on pages 4-5.

Feel like you already work 24/7? You may not be able to but your van can with a graphics package advertising you!

Make your van WORK READY with a drop-down ladder rack or versatile cargo rack.



**MAXIMIZE YOUR CARGO VAN STORAGE VOLUME WITH 44 SERIES WELDED SHELVING.**

**4135G GENERAL CONTRACTOR PACKAGE  
GM Full-Size Long Wheelbase Vans**

| ITEM | MODEL      | DESCRIPTION                          | QTY |
|------|------------|--------------------------------------|-----|
| 1    | 4442       | 42" Welded Utility Rack              | 1   |
| 2    | 4450       | 50" Welded Utility Rack              | 1   |
| 3    | 4432       | 32" Welded Utility Rack              | 1   |
| 4    | DK550      | Door Kit                             | 1   |
| 5    | DV44U4     | Dividers                             | 1   |
| 6    | TA1        | Hook Bar                             | 2   |
| 7    | CL1446R    | Cabinet Locker Tall-Door             | 1   |
| 8    | 9          | 4 Drawer Shallow                     | 1   |
| 9    | 19         | 2 Drawer Medium                      | 1   |
| 10   | DC12       | Drawer Component - 12"               | 1   |
| 11   | DC6        | Drawer Component - 6"                | 3   |
| 12   | DK544      | Door Kit                             | 1   |
| 13   | 28         | Plastic Bins                         | 3   |
| 14   | S1M2HC2FSV | Partition (not pictured)             | 1   |
| 15   | WKC2FSVGM  | GM Partition Wing Kit (not pictured) | 1   |



**4136G INDUSTRIAL SERVICES PACKAGE  
GM Full-Size Long Wheelbase Vans**

| ITEM | MODEL      | DESCRIPTION             | QTY |
|------|------------|-------------------------|-----|
| 1    | 4442       | 42" Welded Utility Rack | 2   |
| 2    | 4450       | 50" Welded Utility Rack | 1   |
| 3    | DC6        | Drawer Component - 6"   | 4   |
| 4    | DC12       | Drawer Component - 12"  | 1   |
| 5    | DV44U4     | Dividers                | 1   |
| 6    | DV44L1     | Dividers                | 3   |
| 7    | DK544      | Door Kit                | 1   |
| 8    | 9          | 4 Drawer Shallow        | 1   |
| 9    | 19         | 2 Drawer Medium         | 1   |
| 10   | 28         | Plastic Bins            | 3   |
| 11   | TA1        | Hook Bar                | 1   |
| 12   | S1M2HC2FSV | Partition               | 1   |
| 13   | WKC2FSVGM  | GM Partition Wing Kit   | 1   |

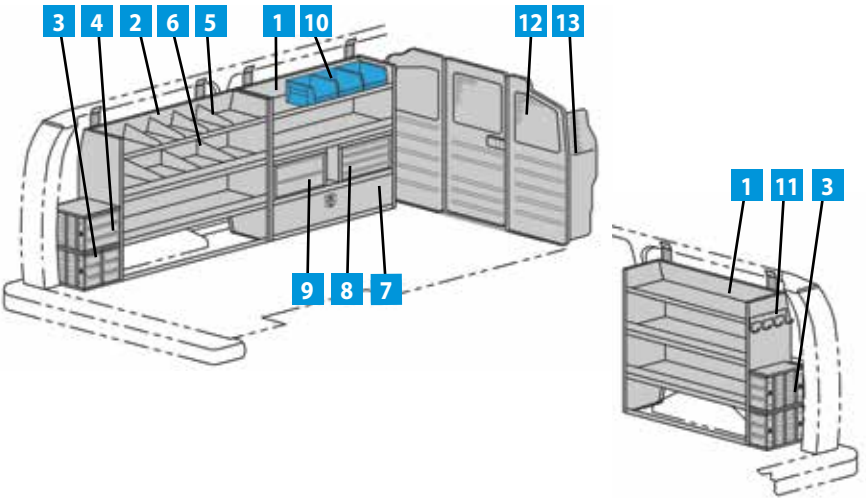

**4138G GENERAL STORAGE PACKAGE  
GM Full-Size Long Wheelbase Vans**

| ITEM | MODEL      | DESCRIPTION             | QTY |
|------|------------|-------------------------|-----|
| 1    | 4450       | 50" Welded Utility Rack | 2   |
| 2    | 4442       | 42" Welded Utility Rack | 1   |
| 3    | DC12       | Drawer Component - 12"  | 3   |
| 4    | DC6        | Drawer Component - 6"   | 8   |
| 5    | DK550      | Door Kit                | 1   |
| 6    | SF11218DC  | 18" wide DC shelf       | 2   |
| 7    | DV44U4     | Dividers                | 1   |
| 8    | 9          | 4 Drawer Shallow        | 1   |
| 9    | 19         | 2 Drawer Medium         | 1   |
| 10   | 28         | Plastic Bins            | 4   |
| 11   | TA1        | Hook Bar                | 1   |
| 12   | S1M2HC2FSV | Partition               | 1   |
| 13   | WKC2FSVGM  | GM Partition Wing Kit   | 1   |

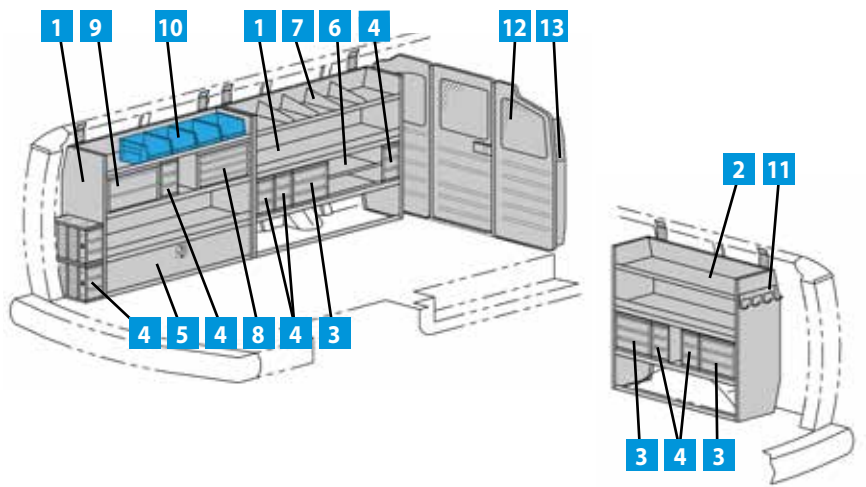

**STORAGE SYSTEMS THAT ARE AS FLEXIBLE AS YOU ARE.**

Is there anything that you don't have in the back of your van? For all the fittings, pipe and tools that you need to transport, you need an Adrian Steel Work Ready van with the trade specific equipment you'll use to do the job and a graphics package advertising what you do.

**PLUMBING, HEATING & A/C REPAIR PACKAGE**

**4318G** GM FSV long wheelbase  
**4318GX** GM FSV x-long wheelbase

| ITEM | MODEL      | DESCRIPTION             | QTY |
|------|------------|-------------------------|-----|
| 1    | AD44FP     | ADseries 44" shelf unit | 3   |
| 2    | RKFSVLWB   | Rail Kit for AD series  | 1   |
| 3    | DV14C8     | Divider 8 pack          | 1   |
| 4    | 919        | Three Drawer Combo      | 1   |
| 5    | S1M2HC2FSV | Partition               | 1   |
| 6    | WTR230150  | Welded Tank Rack        | 1   |
| 7    | 19         | Two Drawer Medium       | 2   |
| 8    | DC6        | Drawer Component - 6"   | 3   |
| 9    | DC12       | Drawer Component - 12"  | 1   |
| 10   | DK4208     | 8" Door Kit             | 2   |
| 11   | TA1        | Hook Bar                | 1   |
| 12   | VMA36      | Vice Mount Assembly     | 1   |
| 13   | BRK14EPS   | End Panel Bracket       | 1   |
| 14   | RKAWTR     | Tank Holder Adapter     | 1   |
| 15   | WKC2FSVGM  | Partition Wing Kit      | 1   |



**All Trade Packages include a steel cargo partition.**

**2251G PHVAC PACKAGE**

**GM Full-Size Long Wheelbase Vans**

| ITEM | MODEL     | DESCRIPTION   | QTY |
|------|-----------|---|-----|
| 1    | DS36012H  | Drawer System   | 1   |
| 2    | 4442      | Welded Shelf Rack   | 2   |
| 3    | MD507     | Drawer Cabinet Rack Module (includes: #18, #43, #40, #9, #19) | 1   |
| 4    | DK544     | Door Kit  | 1   |
| 5    | VMA36     | Vise Mount Assembly   | 1   |
| 6    | TA1       | Hook Bar  | 1   |
| 7    | TH50      | 50-lb. Tank Holder  | 1   |
| 8    | 19        | Two Drawer Medium   | 1   |
| 9    | WTR230150 | Three Tank Rack   | 1   |
| 10   | S1M2C2FSV | Partition   | 1   |
| 11   | DV44U4    | Dividers  | 1   |
| 12   | WKC2FSVGM | Partition Wing Kit  | 1   |

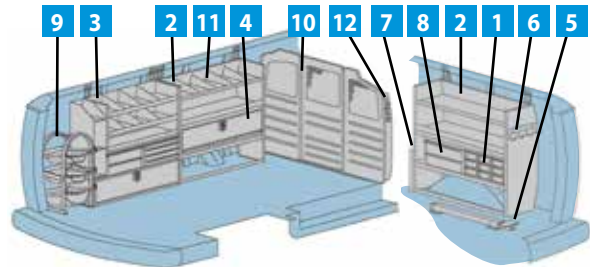

**2261G PHVAC PACKAGE**

**GM Full-Size Long Wheelbase Vans**

| ITEM | MODEL     | DESCRIPTION   | QTY |
|------|-----------|---|-----|
| 1    | 4442      | Welded Shelf Rack                                     | 1   |
| 2    | DV14      | 14" Divider   | 6   |
| 3    | MD507     | Drawer Cabinet Rack Module                            | 1   |
| 4    | DK544     | Door Kit  | 1   |
| 5    | TA1       | Hook Bar  | 1   |
| 6    | DTWL21    | Door Tray with Lid (not shown)                        | 2   |
| 7    | UH50      | Hook 5"   | 2   |
| 8    | HD-42FP   | HD Adjustable Closed End Shelving 46" H, 42" W, 14" D | 1   |
| 9    | S1M2C2FSV | Partition   | 1   |
| 10   | DV44U4    | Dividers  | 1   |
| 11   | WKC2FSVGM | Partition Wing Kit                                    | 1   |

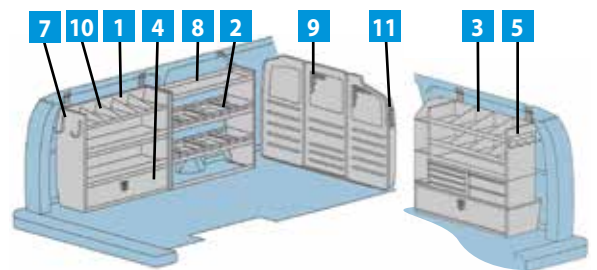

Graphic designed with:



More info on pages 4-5.

**Promote your COOL BRAND!**  
 Your business name **WILL BE** seen with a graphics package for your van!

**MAKE YOUR VAN WORK READY:**  
 Have the small fittings, fasteners and parts taken over your van? Stay in control with a Bin Storage System!



page 18

**IF IT IS YOUR JOB TO KEEP UP WITH THE LATEST TECHNOLOGY, IT'S OUR JOB TO KEEP THAT TECHNOLOGY ORGANIZED AND EASILY ACCESSIBLE!**

Cable TV interiors are designed specifically for service technicians who need to make fast and efficient service and installation calls. Divided shelving and composite drawers are perfect for keeping connectors, adapters, wall plates, cables, splitters and every other small component organized and in its place.

**2258G  
CABLE TV  
PACKAGE**

**GM Full-Size  
Long Wheelbase Vans**

| ITEM | MODEL     | DESCRIPTION              | QTY |
|------|-----------|--------------------------|-----|
| 1    | 1         | Adjustable Shelf Cabinet | 2   |
| 2    | DS36012H  | Nine Drawer System       | 1   |
| 3    | PA9       | First Aid Tray           | 1   |
| 4    | 4442      | Welded Shelf Rack        | 1   |
| 5    | PA8       | Fire Extinguisher        | 1   |
| 6    | PA7       | Reflector Flare Kit      | 1   |
| 7    | TA2       | Hard Hat Holder          | 1   |
| 8    | 50-42     | KD Shelf Rack            | 1   |
| 9    | TA1       | Hook Bar                 | 2   |
| 10   | 9         | Four Drawer Shallow      | 1   |
| 11   | 19        | Two Drawer Medium        | 2   |
| 12   | DDF12     | Data File (not shown)    | 1   |
| 13   | KDRH2     | Cable Reel Holder        | 1   |
| 14   | S1M2C2FSV | Partition                | 1   |
| 15   | DV44U4    | Dividers                 | 1   |
| 15   | WKC2FSVGM | Partition Wing Kit       | 1   |

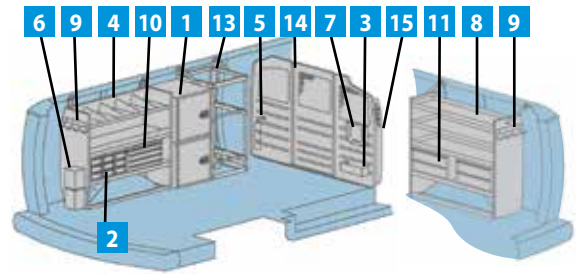

**3230G  
CABLE TV  
PACKAGE**

**GM Full-Size  
Long Wheelbase Vans**

| ITEM | MODEL      | DESCRIPTION              | QTY |
|------|------------|--------------------------|-----|
| 1    | CL1446R    | Cabinet Locker Tall-Door | 1   |
| 2    | MD507      | Drawer Rack Module       | 1   |
| 3    | TA1        | Hook Bar                 | 1   |
| 4    | WRH5       | 5-Bar Wire Reel Holder   | 1   |
| 5    | 4442       | Welded Shelf Rack        | 1   |
| 6    | 50-32      | KD Shelf Rack            | 1   |
| 7    | S1M2HC2FSV | Partition                | 1   |
| 8    | 36         | 18-Drawer Unit           | 1   |
| 9    | 39         | Riser                    | 1   |
| 10   | DV44U4     | Dividers                 | 1   |
| 11   | WKC2FSVGM  | Partition Wing Kit       | 1   |

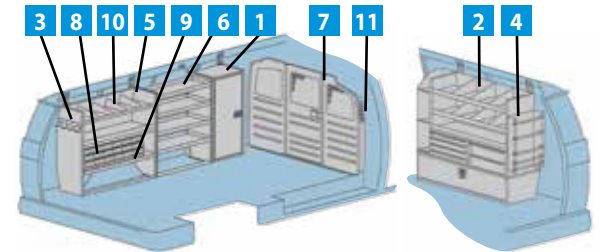

**All Trade Packages include a steel cargo partition.**

**Organize connectors, splitters, adapters and many other small parts in an SPT Tote and tray system. Removable trays have small, divided compartments for easily identifying and choosing what you need to take to the jobsite.**

page 14

**COMMUNICATE YOUR BRAND!**

If you make a living in a highly competitive market you must stand out from all the others. If your work speaks for itself, shouldn't your van speak for you too? Get the attention you deserve with a vehicle graphics package from Commercial Curb Appeal!



**MAKE YOUR VAN  
WORK READY!**

Graphic designed with:



More info on pages 4-5.

**KEEP EVERYTHING IN IT'S PLACE AND EASILY ACCESSIBLE.**

Time is money, and no one wants to pay you to dig through your van to find the connectors, junction boxes or tools you need to do the job. You don't want to wait either, so get your interior, ladder rack and graphics wrap all done at one place.

**ELECTRICAL & GAS APPLIANCE REPAIR PACKAGE**

**4319G** GM FSV long wheelbase  
**4319GX** GM FSV x-long wheelbase

| ITEM | MODEL      | DESCRIPTION             | QTY |
|------|------------|-------------------------|-----|
| 1    | AD44FP     | ADseries 44" shelf unit | 3   |
| 2    | RKFSVLWB   | Rail Kit for AD series  | 1   |
| 3    | DV14C8     | Divider 8 pack          | 1   |
| 4    | 919        | Three Drawer Combo      | 1   |
| 5    | S1M2HC2FSV | Partition               | 1   |
| 6    | WRH5       | Wire Reel Holder        | 1   |
| 7    | 19         | Two Drawer Medium       | 1   |
| 8    | DK4208     | 8" Door Kit             | 2   |
| 9    | DC6        | Drawer Component - 6"   | 3   |
| 10   | DC12       | Drawer Component - 12"  | 1   |
| 11   | 9          | Four Drawer Shallow     | 1   |
| 12   | TA1        | Hook Bar                | 1   |
| 13   | BRK14EPS   | End Panel Bracket       | 3   |
| 14   | WKC2FSVGM  | Partition Wing Kit      | 1   |

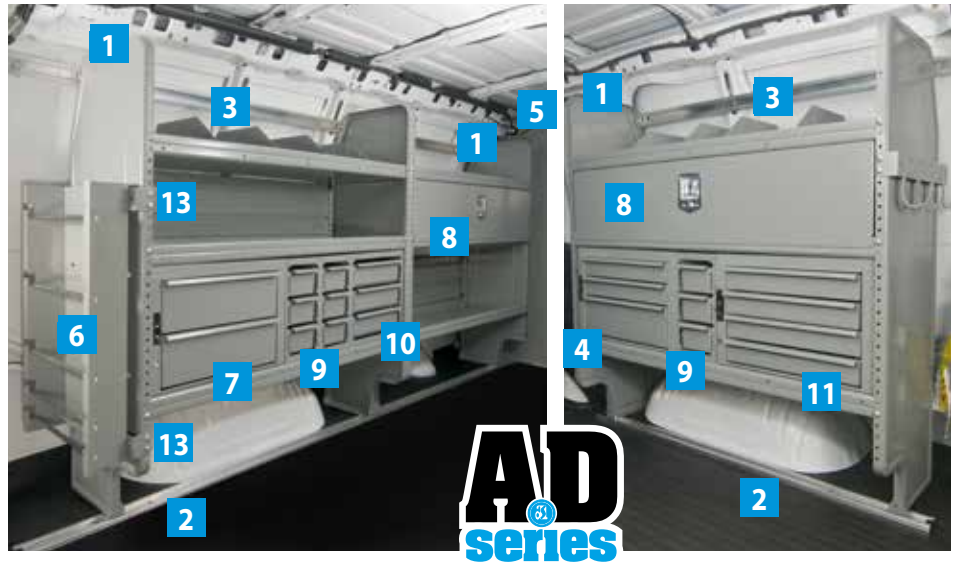

**2252G ELECTRICAL CONTRACTOR PACKAGE**

**GM Full-Size Long Wheelbase Vans**

| ITEM | MODEL     | DESCRIPTION   | QTY |
|------|-----------|---|-----|
| 1    | DS36012H  | Nine Drawer System  | 1   |
| 2    | 4442      | Welded Shelf Rack   | 1   |
| 3    | DV44U4    | Dividers  | 1   |
| 4    | DV14      | 14" Divider   | 8   |
| 5    | MD507     | Drawer Cabinet Rack Module  | 1   |
| 6    | DK542     | Door Kit  | 1   |
| 7    | TA1       | Hook Bar  | 2   |
| 8    | 19        | Two Drawer Medium   | 1   |
| 9    | HD-42FP   | Heavy-Duty Adjustable KD Shelving Overall Size: 46" H, 42" W, 14" D | 1   |
| 10   | WRH5      | 5-Bar Wire Reel Holder  | 1   |
| 11   | S1M2C2FSV | Partition   | 1   |
| 12   | WKC2FSVGM | Partition Wing Kit  | 1   |

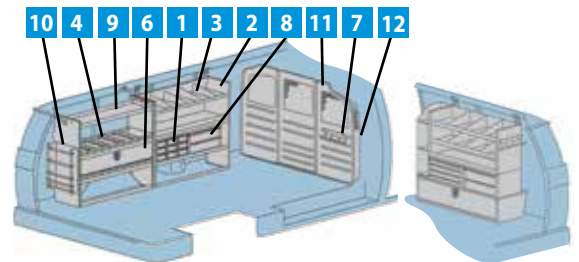

**2262G ELECTRICAL CONTRACTOR PACKAGE**

**GM Full-Size Long Wheelbase Vans**

| ITEM | MODEL     | DESCRIPTION   | QTY |
|------|-----------|---|-----|
| 1    | 4442      | Welded Shelf Rack   | 1   |
| 2    | DV14      | 14" Dividers  | 6   |
| 3    | MD506     | Drawer Cabinet Module   | 1   |
| 4    | DK544     | Door Kit  | 1   |
| 5    | TA1       | Hook Bar  | 1   |
| 6    | DTWL21    | Door Tray with Lid (not shown)                                      | 2   |
| 7    | UH50      | Hook 5"   | 2   |
| 8    | HD-42FP   | Heavy-Duty Adjustable KD Shelving Overall Size: 46" H, 42" W, 14" D | 1   |
| 9    | S1M2C2FSV | Partition   | 1   |
| 10   | DV44U4    | Dividers  | 1   |
| 11   | WKC2FSVGM | Partition Wing Kit  | 1   |

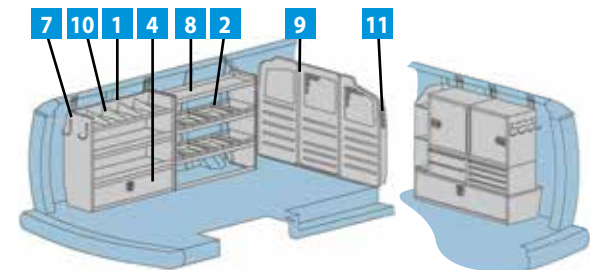

Graphic designed with:

commercial CurbAppeal

More info on pages 4-5.

**Electrify your brand with a rolling billboard at every service call.**

**MAKE YOUR VAN WORK READY:**  
 Carry ladders safely and securely on the top of your van with a LoadsRite or Grip-Lock ladder rack.

**THE KEY TO BEING A MOBILE LOCKSMITH IS HAVING EVERYTHING YOU NEED WHEREVER YOU ARE.**

Whether you are helping stranded motorists get back into their vehicle or installing a home security system, having everything needed for the job will keep your work day or night operating efficiently.

**2253G  
ALARM  
PACKAGE**

**GM Full-Size  
Long Wheelbase Vans**

| ITEM | MODEL     | DESCRIPTION                       | QTY |
|------|-----------|-----------------------------------|-----|
| 1    | 33        | KD Shelf Rack                     | 1   |
| 2    | 1         | Adjustable Shelf Cabinet          | 1   |
| 3    | 12        | Open Side Shelf Cabinet           | 1   |
| 4    | DC6       | Drawer Component 6"               | 3   |
| 5    | 43        | Catalog File                      | 1   |
| 6    | 4442      | Welded Shelf Rack                 | 1   |
| 7    | DV14      | 14" Dividers                      | 8   |
| 8    | DK544     | Door Kit                          | 2   |
| 9    | TA1       | Hook Bar                          | 2   |
| 10   | 2         | Four Drawer Medium                | 1   |
| 11   | 9         | Four Drawer Shallow               | 1   |
| 12   | 19        | Two Drawer Medium                 | 1   |
| 13   | HD-42FP   | Closed End Adjustable KD Shelving | 1   |
| 14   | S1M2C2FSV | Partition                         | 1   |
| 15   | DV44U4    | Dividers                          | 1   |
| 16   | WKC2FSVGM | Partition Wing Kit                | 1   |

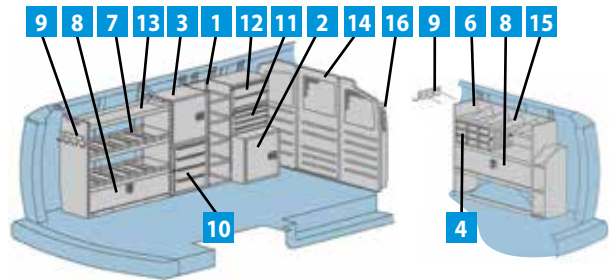

**2255G  
LOCKSMITH  
PACKAGE**

**GM Full-Size  
Long Wheelbase Vans**

| ITEM | MODEL      | DESCRIPTION           | QTY |
|------|------------|-----------------------|-----|
| 1    | 17A        | Catalog File          | 1   |
| 2    | MD506      | Drawer Cabinet Module | 1   |
| 3    | MD608      | Workbench Module      | 1   |
| 4    | TA1        | Hook Bar              | 1   |
| 5    | S1M2HC2FSV | Partition             | 1   |
| 6    | WKC2FSVGM  | Partition Wing Kit    | 1   |

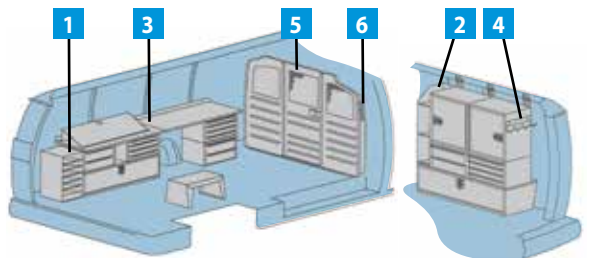

**Key Machine Base** holds key cutting machines at a 25-degree slope towards the operator for easy cutting. Mounts to No. 54 Workbench. Two sizes available to hold one or two machines.  
**KMB36** - 36" Key Machine Base  
**KMB18** - 18" Key Machine Base



**25° slope for easy cutting**



**MAKE IT A WORK READY VAN!**

Day and night, you can lock in those leads with a vehicle graphic wrap from Commercial Curb Appeal.

Design your own look and have it installed at the same time as your interior!



Graphic designed with:



More info on pages 4-5.

**THE ONLY VAN INTERIOR DESIGNED AROUND THE AUTOMOTIVE GLASS REPAIR PROFESSIONAL. FEATURING BURCO GLASS RACKS.**

Burco S-Series glass racks fit any van and are ideal for loading and unloading from the top or side. They are very adaptable with a variety of widths and mast extensions to best fit your application.



The 45047 Burco Glass Rack accommodates up to 11 windshields. Designed for modern windshields with six 14.5" and six 23.5" divider posts. The glass rack can transport both taller windshields and smaller glass panels safely. Each post is surrounded with a protective foam cover and a twist and lock top to keep your glass safe and secure.

Package shown with S-M-C partition option.



AGSS24 shown with AGSCH2 Suction Cup Holder

**Storage Station**  
Store all your window prep supplies (glass primers, razor blades, cleaning supplies, power and hand tools) on the Storage Station. The removable blue bins allow you to take parts with you. The AGSS24 measures 36" high by 12" deep by 42" long.



AGTW4

**Trim Weld Storage**  
Safely store windshield gaskets with the AGTW4. Easily pull out the length you need and forget about damaged material that costs time and money! Accommodates 24" by 24" boxed gaskets and most sizes of round gasket containers.

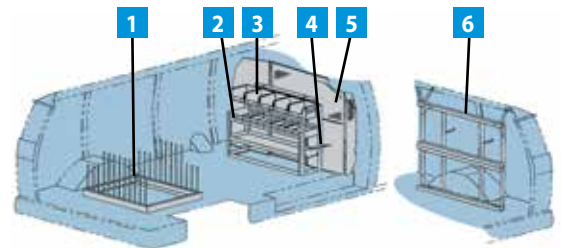

**4145G  
AUTO GLASS INTERIOR PACKAGE  
GM Express / Savana LWB**

| ITEM | MODEL     | DESCRIPTION                     | QTY |
|------|-----------|---------------------------------|-----|
| 1    | 45047     | S-111524B Burco Auto Glass Rack | 1   |
| 2    | AGSS24    | Auto Glass Storage Station      | 1   |
| 3    | 28        | Plastic Bins                    | 5   |
| 4    | AGSCH2    | Suction Cup Holder              | 1   |
| 5    | X1FSV     | X1 Partition                    | 1   |
| 6    | AGTW4     | Auto Glass Trim Weld Storage    | 1   |
| 7    | WKX1FSVGM | Partition Wing Kit              | 1   |

**EXPRESS ACCESS & SAVANA PRO UPFITS PROVIDE EASY ACCESS AND FLEXIBLE STORAGE.**

Side panels allow access to bins, drawers and shelving for easy access from the outside of the van.

**2940G  
GENERAL SERVICE  
PACKAGE**

| ITEM | MODEL      | DESCRIPTION                 | QTY |
|------|------------|-----------------------------|-----|
| 1    | 24         | Plastic Bin 15" X 8" X 7"   | 10  |
| 2    | DK552A     | Door Kit                    | 1   |
| 3    | AP6        | KD Shelf Unit               | 1   |
| 4    | 919        | Three Drawer Combo          | 1   |
| 5    | MB121      | Strside Frnt Sill Plate 44" | 1   |
| 6    | MB122      | Strside Rear Sill Plate 52" | 1   |
| 7    | MB123      | Crbside Sill Plate 42"      | 1   |
| 8    | AP1        | KD Shelf Unit               | 1   |
| 9    | AP2        | KD Shelf Unit               | 1   |
| 10   | S1M2HC2FSV | Partition                   | 1   |
| 11   | WKC2FSVGM  | Partition Wing Kit          | 1   |

**2942G  
HVAC INTERIOR  
PACKAGE**

| ITEM | MODEL      | DESCRIPTION                 | QTY |
|------|------------|-----------------------------|-----|
| 1    | VM42       | Floor Rail 42"              | 1   |
| 2    | DV14       | 14" Divider                 | 4   |
| 3    | 24         | Plastic Bin 15" X 8" X 7"   | 12  |
| 4    | DK544      | Door Kit                    | 1   |
| 5    | VMA 36     | Vise Mount Assembly         | 1   |
| 6    | TA1        | Hook Bar                    | 2   |
| 7    | TH50       | 50-lb. Tank Holder          | 1   |
| 8    | SA-10      | Single Wide Deep Stow-All   | 1   |
| 9    | WTR230150  | Three Tank Rack             | 1   |
| 10   | 919        | Three Drawer Combo          | 1   |
| 11   | MB121      | Strside Frnt Sill Plate 44" | 1   |
| 12   | MB122      | Strside Rear Sill Plate 52" | 1   |
| 13   | MB123      | Crbside Sill Plate 42"      | 1   |
| 14   | AP1        | KD Shelf Unit               | 1   |
| 15   | AP3        | KD Shelf Unit               | 1   |
| 16   | AP 5       | KD Shelf Unit               | 1   |
| 17   | S1M2HC2FSV | Partition                   | 1   |
| 18   | WKC2FSVGM  | Partition Wing Kit          | 1   |

**2941G  
ELECTRIC & GAS  
REPAIR  
PACKAGE**

| ITEM | MODEL      | DESCRIPTION                 | QTY. |
|------|------------|-----------------------------|------|
| 1    | VM42       | Floor Rail 42"              | 1    |
| 2    | DV14       | 14" Divider                 | 5    |
| 3    | 24         | Plastic Bin 15" X 8" X 7"   | 12   |
| 4    | TA1        | Hook Bar                    | 2    |
| 5    | SA-10      | Single Wide Deep Stow-All   | 1    |
| 6    | WRH5       | 5-Bar Wire Reel Holder      | 1    |
| 7    | 919        | Three Drawer Combo          | 1    |
| 8    | MB121      | Strside Frnt Sill Plate 44" | 1    |
| 9    | MB122      | Strside Rear Sill Plate 52" | 1    |
| 10   | MB123      | Crbside Sill Plate 42"      | 1    |
| 11   | AP1        | KD Shelf Unit               | 1    |
| 12   | AP3        | KD Shelf Unit               | 1    |
| 13   | AP4        | KD Shelf Unit               | 1    |
| 14   | S1M2HC2FSV | Partition                   | 1    |
| 15   | WKC2FSVGM  | Partition Wing Kit          | 1    |

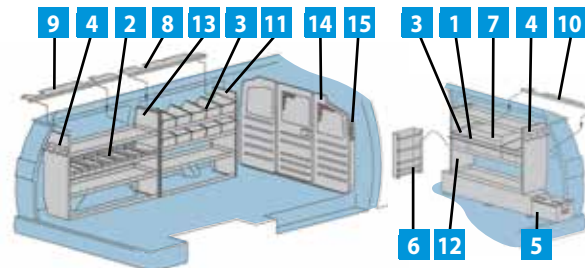
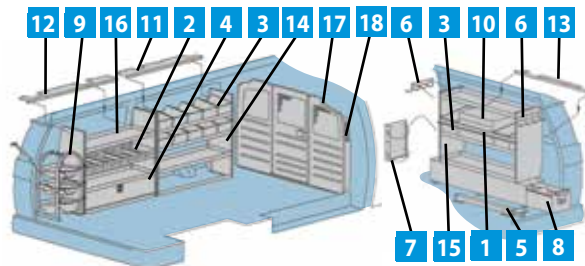
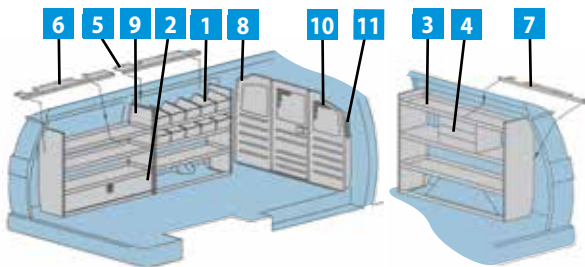





**GM POLY PROTECTO-VAN LINER**

- Protect your GM van from the inside with a Protec-to-Van Liner Kit.
- Designed to minimize the damage to the walls of your van.
- Liner panels are molded to conform to the shape of the van walls and run from floor to ceiling.
- The kit includes full length E-track and a hinged-door partition.
- Available for long and extended long wheelbase GM full size vans.

**3056G** fits 2014-older Express/Savana LWB

**3057G** fits 2014-older Express/Savana XLWB

**5384G** fits 2015-on Express/Savana LWB

**5384GX** fits 2015-on Express/Savana XLWB



Choose from the Grip-Lock or LoadsRite ladder racks to get your ladders out of the van and on the roof for secure transportation.



page 24

Keep the cargo floor open for transporting large items. A Ladder Keeper will keep a step ladder secure on the ceiling and out of the way!

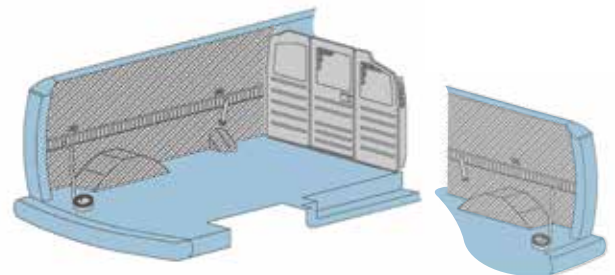

**Vehicle fit:** Poly Protecto-Van Liner fit full-size GM vans with long and extended long wheelbases. For use with 60/40 and sliding side doors.

Optional Floor Mat ordering information is on page 18.

**4959**  
**CARGO MANAGEMENT PACKAGE #1**  
 One ADseries Shelf and Steel Partition  
**City Express**

| ITEM | MODEL    | DESCRIPTION          | QTY |
|------|----------|----------------------|-----|
| 1    | AD32FP   | ADseries Shelf 32"   | 1   |
| 2    | RKNV2-SS | Rail Kit- streetside | 1   |
| 3    | P2NV2S   | Steel Partition      | 1   |



**4960**  
**CARGO MANAGEMENT PACKAGE #2**  
 One ADseries Shelf and Wire Partition  
**City Express**

| ITEM | MODEL    | DESCRIPTION          | QTY |
|------|----------|----------------------|-----|
| 1    | AD32FP   | ADseries Shelf 32"   | 1   |
| 2    | RKNV2-SS | Rail Kit- streetside | 1   |
| 3    | P2NV2FW  | Wire Partition       | 1   |



**4961**  
**CARGO MANAGEMENT PACKAGE #3**  
 One HD Series Shelf and Steel Partition  
**City Express**

| ITEM | MODEL    | DESCRIPTION          | QTY |
|------|----------|----------------------|-----|
| 1    | HD-32NV2 | HD Shelf 12"x32"     | 1   |
| 2    | RKNV2-SS | Rail Kit- streetside | 1   |
| 3    | P2NV2S   | Steel Partition      | 1   |



**4962**  
**CARGO MANAGEMENT PACKAGE #4**  
 One HD Series Shelf and Wire Partition  
**City Express**

| ITEM | MODEL    | DESCRIPTION         | QTY |
|------|----------|---------------------|-----|
| 1    | HD-32NV2 | HD Shelf 12"x32"    | 1   |
| 2    | RKNV2-SS | Rail Kit-streetside | 1   |
| 3    | P2NV2FW  | Wire Partition      | 1   |



**4964**  
**CARGO MANAGEMENT PACKAGE #1**  
 Includes two 32" ADseries Shelves  
**City Express**

| ITEM | MODEL    | DESCRIPTION          | QTY |
|------|----------|----------------------|-----|
| 1    | AD32FP   | ADseries Shelf 32"   | 2   |
| 2    | RKNV2-SS | Rail Kit- streetside | 1   |
| 3    | RKNV2-CS | Rail Kit- curbside   | 1   |
| 4    | P2NV2S   | Steel Partition      | 1   |
| 5    | TA1WAD   | Hook Bar             | 1   |

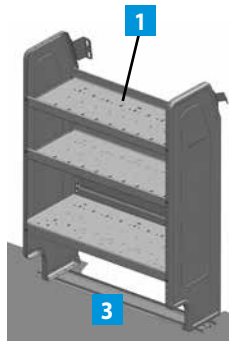
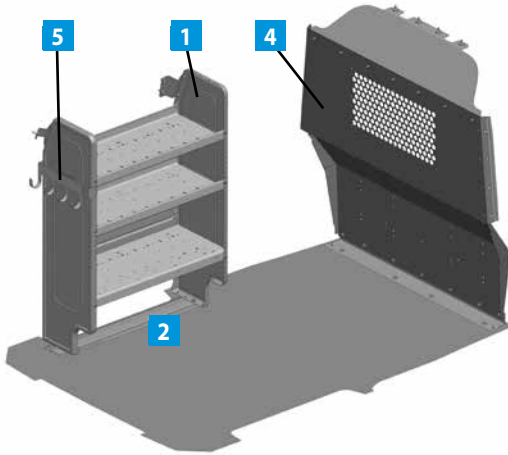

**4965**  
**CARGO MANAGEMENT PACKAGE #2**  
 Includes two 32" HD Series Shelves  
**City Express**

| ITEM | MODEL    | DESCRIPTION          | QTY |
|------|----------|----------------------|-----|
| 1    | HD-32NV2 | HD Shelf 12"x32"     | 2   |
| 2    | RKNV2-SS | Rail Kit- streetside | 1   |
| 3    | RKNV2-CS | Rail Kit- curbside   | 1   |
| 4    | P2NV2S   | Steel Partition      | 1   |
| 5    | TA1      | Hook Bar             | 1   |

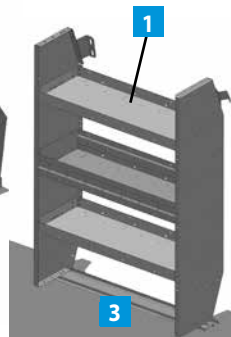
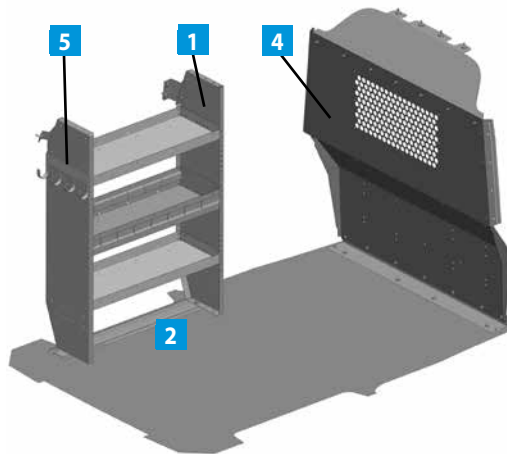

**4966**

**CARGO MANAGEMENT PACKAGE #3**

Includes two 32" & one 28" ADseries Shelves  
City Express

| ITEM | MODEL      | DESCRIPTION              | QTY |
|------|------------|--------------------------|-----|
| 1    | AD32FP     | ADseries Shelf 32"       | 2   |
| 2    | RK67NV2-SS | Rail Kit- dbl streetside | 1   |
| 3    | RKNV2-CS   | Rail Kit- curbside       | 1   |
| 4    | P2NV2S     | Steel Partition          | 1   |
| 5    | AD28NV2    | ADseries Shelf 28"       | 1   |
| 6    | TA1WAD     | Hook Bar                 | 1   |

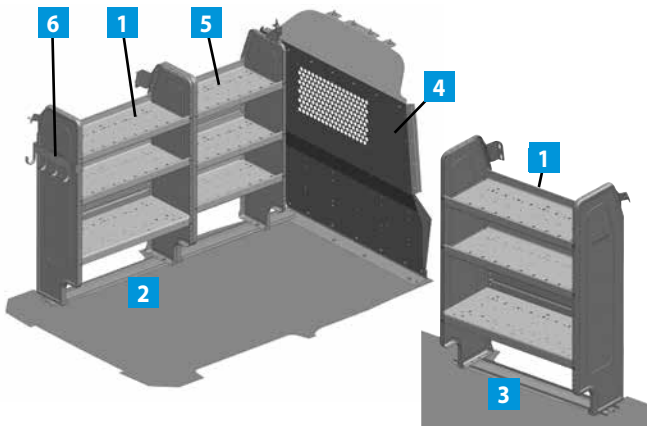

**4967**

**CARGO MANAGEMENT PACKAGE #4**

Includes two 32" & one 28" HD Series Shelves  
City Express

| ITEM | MODEL      | DESCRIPTION             | QTY |
|------|------------|-------------------------|-----|
| 1    | HD-32NV2   | HD Shelf 12"x32"        | 2   |
| 2    | RK67NV2-SS | Rail Kit-dbl streetside | 1   |
| 3    | RKNV2-CS   | Rail Kit-curbside       | 1   |
| 4    | P2NV2S     | Steel Partition         | 1   |
| 5    | HD-28NV2   | HD Shelf 12"x28"        | 1   |
| 6    | TA1        | Hook Bar                | 1   |

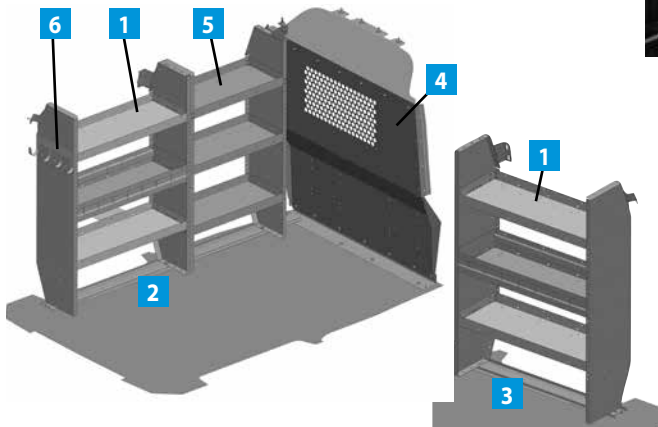

**5098  
COMMERCIAL SHELVING PACKAGE  
14" ADSERIES SHELVING  
City Express**

| ITEM | MODEL    | DESCRIPTION          | QTY |
|------|----------|----------------------|-----|
| 1    | P2NV2S   | Steel Partition,     | 1   |
| 2    | RKNV2-SS | Rail Kit- streetside | 1   |
| 3    | RKNV2-CS | Rail Kit- curbside   | 1   |
| 4    | AD32FP   | ADseries Shelf 32"   | 2   |
| 5    | DV14C8   | Divider kit of 8     | 1   |
| 6    | DK532    | Door Kit             | 1   |
| 7    | TA1WAD   | Four Hook Bar        | 1   |

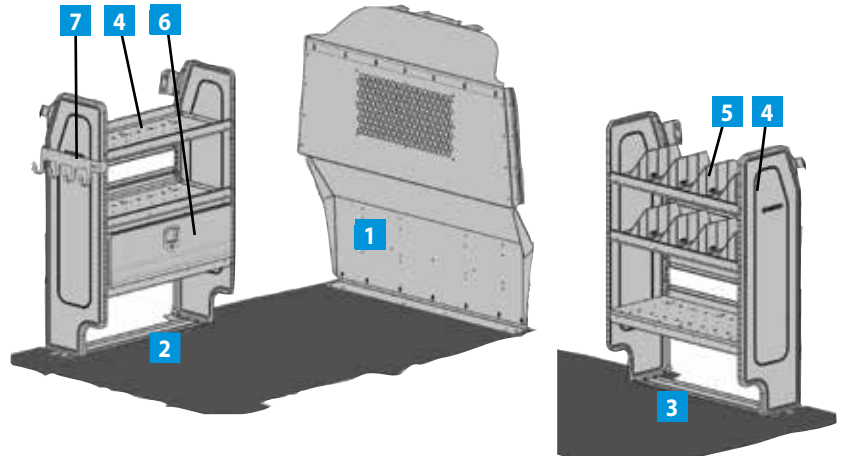

**5100  
GENERAL SERVICE PACKAGE  
14" ADSERIES SHELVING  
City Express**

| ITEM | MODEL      | DESCRIPTION         | QTY |
|------|------------|---------------------|-----|
| 1    | P2NV2S     | Steel Partition     | 1   |
| 2    | RK67NV2-SS | Rail Kit-streetside | 1   |
| 3    | RK67NV2-CS | Rail Kit- curbside  | 1   |
| 4    | AD32FP     | ADseries Shelf 32"  | 2   |
| 5    | TA1WAD     | Four Hook Bar       | 1   |
| 6    | SBIN060614 | 6" Snap-in Bin      | 6   |
| 7    | DC6        | 6" Drawer Component | 5   |
| 8    | DV14C8     | Divider kit of 8    | 1   |
| 9    | AD28NV2    | ADseries Shelf 28"  | 2   |
| 10   | 919        | 3 Drawer Combo      | 1   |

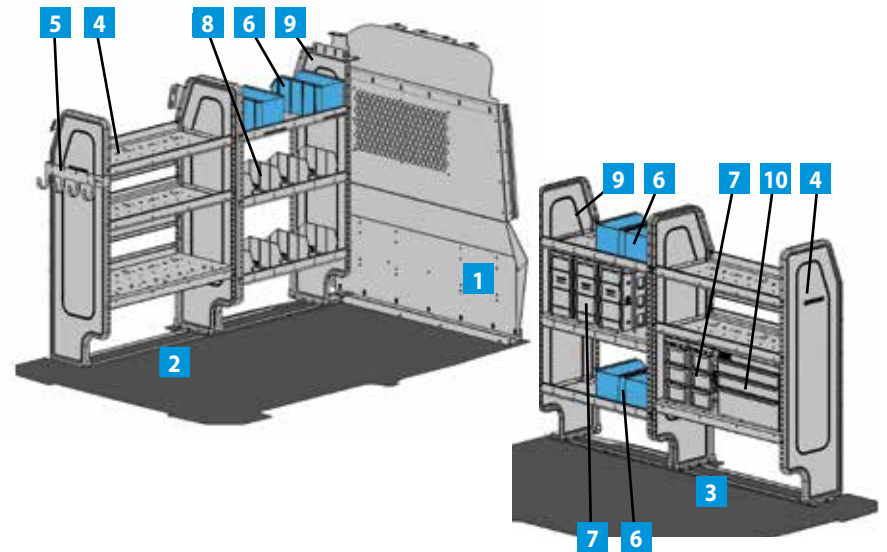

**5097  
TELECOMMUNICATIONS PACKAGE  
14" ADSERIES SHELVING  
City Express**

| ITEM | MODEL      | DESCRIPTION          | QTY |
|------|------------|----------------------|-----|
| 1    | P2NV2S     | Steel Partition      | 1   |
| 2    | RK67NV2-SS | Rail Kit- streetside | 1   |
| 3    | RKNV2-CS   | Rail Kit- curbside   | 1   |
| 4    | AD32FP     | ADseries Shelf 32"   | 2   |
| 5    | SBIN060614 | 6" Snap-in Bin       | 2   |
| 6    | DC6        | 6" Drawer Component  | 3   |
| 7    | DC12       | 12" Drawer Component | 1   |
| 8    | DV14C8     | Divider kit of 8     | 1   |
| 9    | UH50       | 5" Hook              | 2   |
| 10   | AD28NV2    | ADseries Shelf 28"   | 1   |
| 11   | DK532      | Door Kit             | 1   |
| 12   | 19         | 2 Drawer Medium      | 1   |

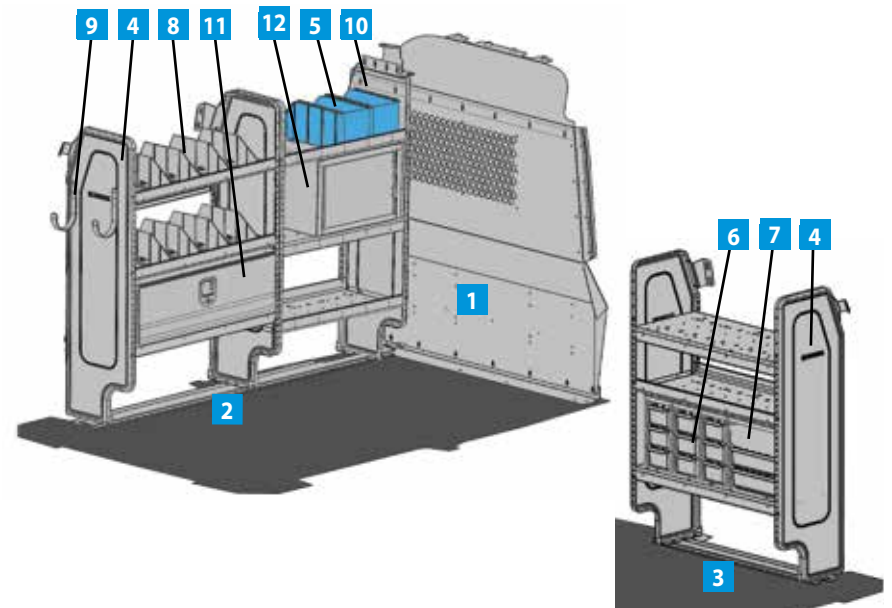

**5096  
PLUMBING PACKAGE  
14" ADSERIES SHELVING  
City Express**

| ITEM | MODEL      | DESCRIPTION            | QTY |
|------|------------|------------------------|-----|
| 1    | P2NV2S     | Steel Partition        | 1   |
| 2    | RK67NV2-SS | Rail Kit-streetside    | 1   |
| 3    | RKNV2-CS   | Rail Kit-curbside      | 1   |
| 4    | AD32FP     | ADseries Shelf 32"     | 2   |
| 5    | SBIN060614 | 6" Snap-in Bin         | 10  |
| 6    | 919        | Drawer Unit            | 1   |
| 7    | DC6        | 6" Drawer Component    | 5   |
| 8    | UH50       | 5" Hook                | 2   |
| 9    | DC12       | 12" Drawer Component   | 1   |
| 10   | AD28NV2    | ADseries Shelf 28"     | 1   |
| 11   | 9          | 4 Drawer Shallow       | 1   |
| 12   | SRAILAD32  | Bin Retention Rail 32" | 2   |
| 13   | BAGSRAIL   | Fastener Bag           | 1   |

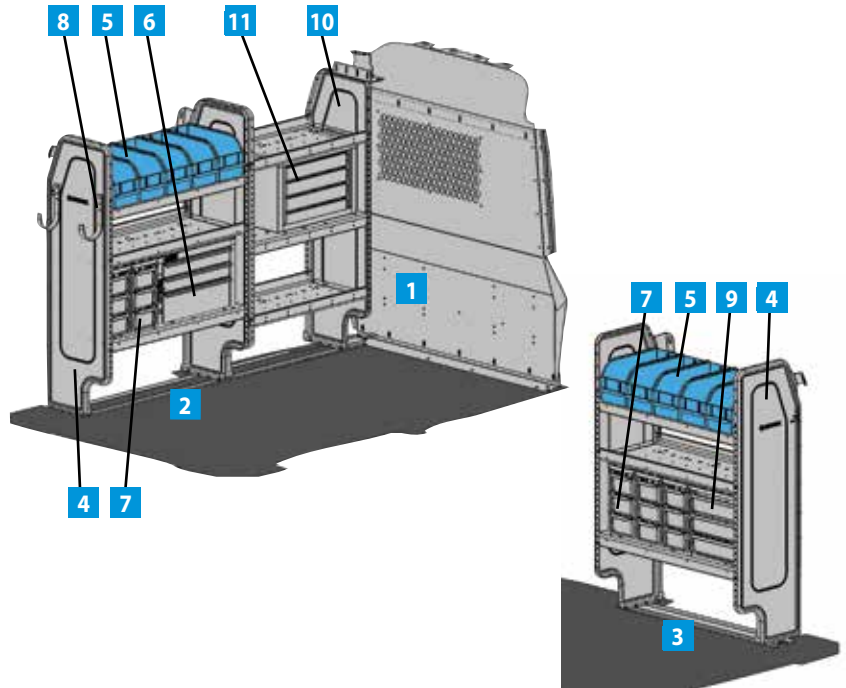

**5099  
ELECTRICAL PACKAGE  
14" ADSERIES SHELVING  
City Express**

| ITEM | MODEL      | DESCRIPTION            | QTY |
|------|------------|------------------------|-----|
| 1    | P2NV2S     | Steel Partition        | 1   |
| 2    | RK67NV2-SS | Rail Kit-streetside    | 1   |
| 3    | RKNV2-CS   | Rail Kit-curbside      | 1   |
| 4    | AD32FP     | ADseries Shelf 32"     | 2   |
| 5    | TA1WAD     | Four Hook Bar          | 2   |
| 6    | SBIN060614 | 6" Snap-in Bin         | 8   |
| 7    | DC6        | 6" Drawer Component    | 3   |
| 8    | DC12       | 12" Drawer Component   | 1   |
| 9    | DV14C8     | Divider kit of 8       | 1   |
| 10   | AD28NV2    | ADseries Shelf 28"     | 1   |
| 11   | 919        | 3 Drawer Combo         | 1   |
| 12   | DK532      | Door Kit               | 1   |
| 13   | SRAILAD32  | Bin Retention Rail 32" | 1   |
| 14   | BAGSRAIL   | Fastener Bag           | 1   |

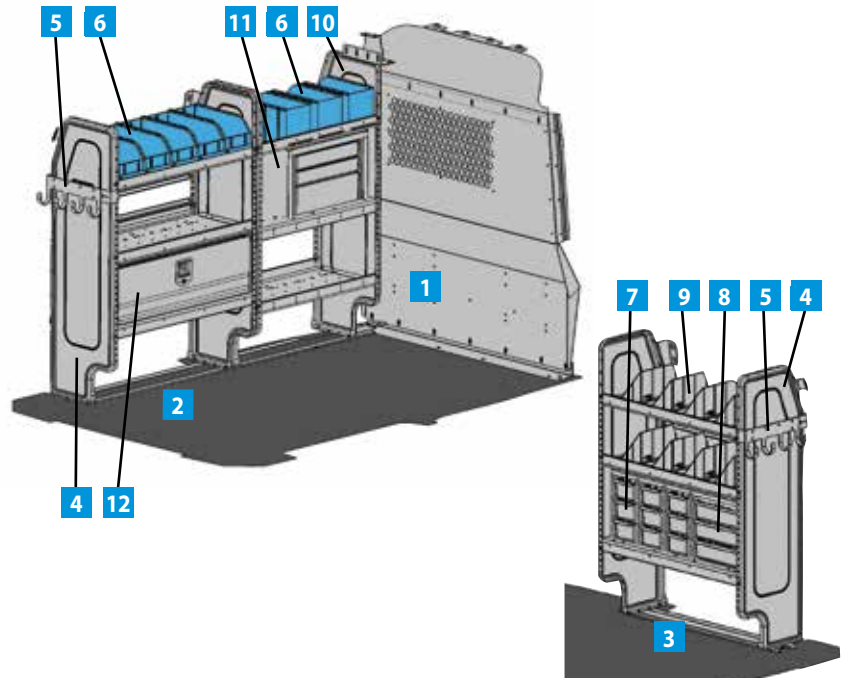

**5082  
COMMERCIAL SHELVING PACKAGE  
12" HD SERIES SHELVING  
City Express**

| ITEM | MODEL    | DESCRIPTION         | QTY |
|------|----------|---------------------|-----|
| 1    | P2NV2S   | Steel Partition     | 1   |
| 2    | RKNV2-SS | Rail Kit streetside | 1   |
| 3    | RKNV2-CS | Rail Kit curbside   | 1   |
| 4    | HD-32NV2 | HD Shelf 12"x32"    | 2   |
| 5    | DV12     | Dividers            | 6   |
| 6    | DK532    | Door Kit            | 1   |
| 7    | TA1      | Four Hook Bar       | 1   |

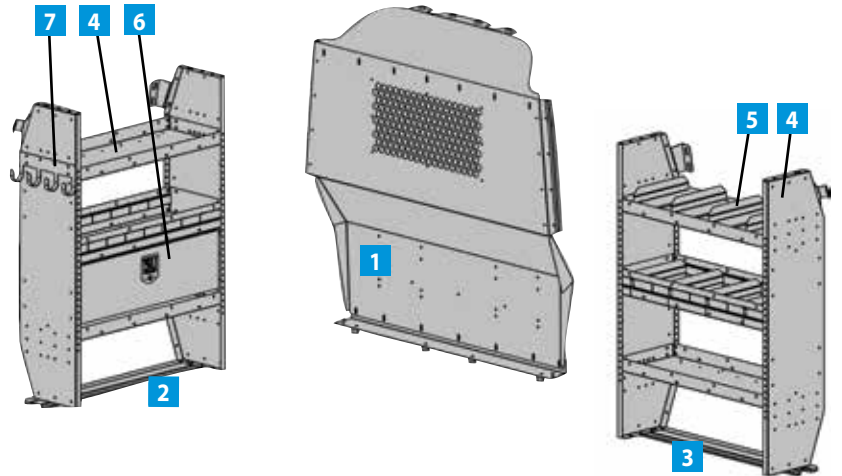

**5084  
GENERAL SERVICE PACKAGE  
12" HD SERIES SHELVING  
City Express**

| ITEM | MODEL      | DESCRIPTION         | QTY |
|------|------------|---------------------|-----|
| 1    | P2NV2S     | Steel Partition     | 1   |
| 2    | RK67NV2-SS | Rail Kit streetside | 1   |
| 3    | RK67NV2-CS | Rail Kit curbside   | 1   |
| 4    | HD-32NV2   | HD Shelf 12"x32"    | 2   |
| 5    | TA1        | Four Hook Bar       | 1   |
| 6    | 28         | Blue Bin            | 6   |
| 7    | DC6        | 6" Drawer Component | 5   |
| 8    | DV12       | Dividers            | 8   |
| 9    | HD-28NV2   | HD Shelf 12"x28"    | 2   |
| 10   | 919        | 3 Drawer Combo      | 1   |

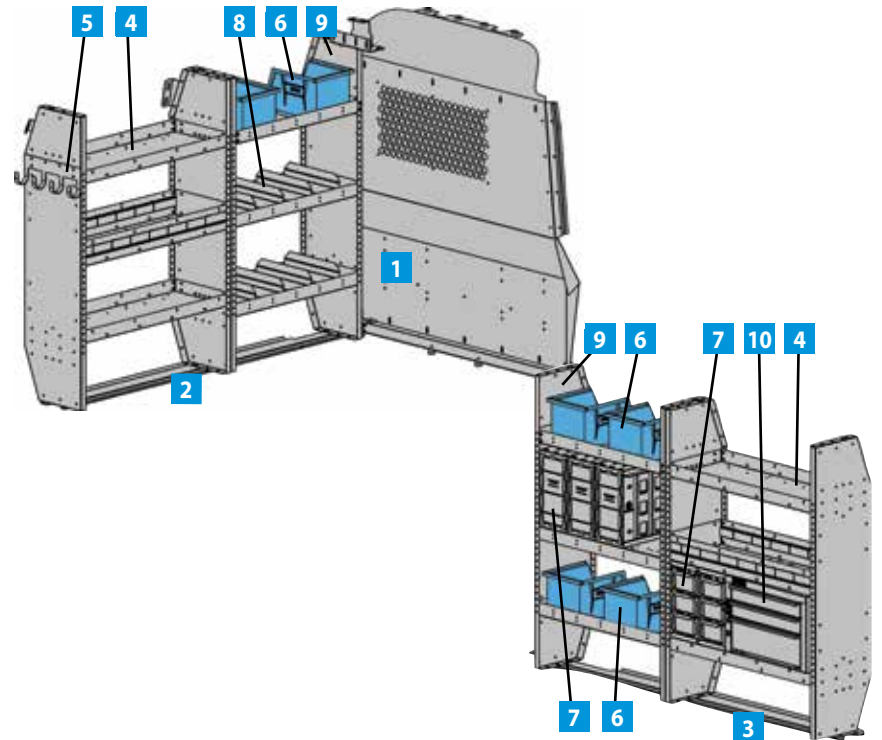

**5081  
TELECOMMUNICATIONS PACKAGE  
12" HD SERIES SHELVING  
City Express**

| ITEM | MODEL      | DESCRIPTION          | QTY |
|------|------------|----------------------|-----|
| 1    | P2NV2S     | Steel Partition      | 1   |
| 2    | RK67NV2-SS | Rail Kit streetside  | 1   |
| 3    | RKNV2-CS   | Rail Kit curbside    | 1   |
| 4    | HD-32NV2   | HD Shelf 12"x32"     | 2   |
| 5    | 28         | Blue Bin             | 2   |
| 6    | DC6        | 6" Drawer Component  | 3   |
| 7    | DC12       | 12" Drawer Component | 1   |
| 8    | DV12       | Dividers             | 8   |
| 9    | UH50       | 5" Hook              | 2   |
| 10   | HD-28NV2   | HD Shelf 12"x28"     | 1   |
| 11   | DK532      | Door Kit             | 1   |
| 12   | 19         | 2 Drawer Medium      | 1   |

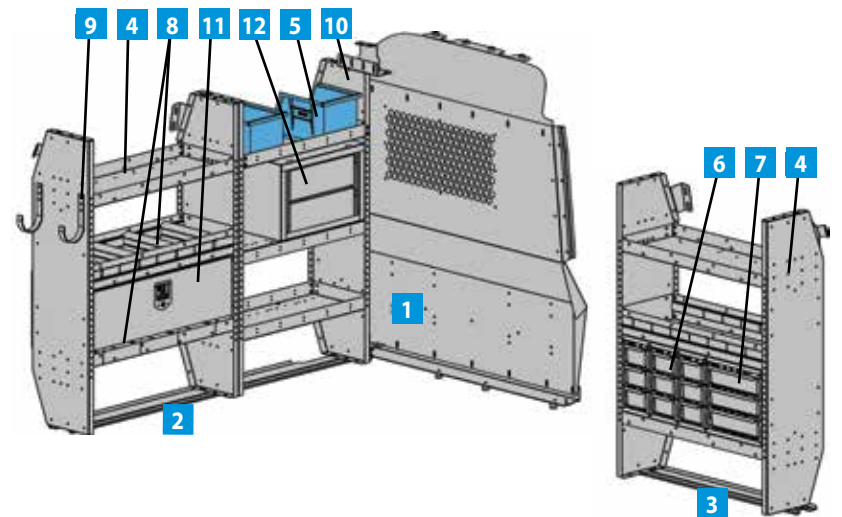

**5080  
PLUMBING PACKAGE  
12" HD SERIES SHELVING  
City Express**

| ITEM | MODEL      | DESCRIPTION          | QTY |
|------|------------|----------------------|-----|
| 1    | P2NV2S     | Steel Partition      | 1   |
| 2    | RK67NV2-SS | Rail Kit streetside  | 1   |
| 3    | RKNV2-CS   | Rail Kit curbside    | 1   |
| 4    | HD-32NV2   | HD Shelf 12"x32"     | 2   |
| 5    | 28         | Blue Bin             | 8   |
| 6    | 919        | 3 Drawer Combo       | 1   |
| 7    | DC6        | 6" Drawer Component  | 5   |
| 8    | UH50       | 5" Hook              | 2   |
| 9    | DC12       | 12" Drawer Component | 1   |
| 10   | HD-28NV2   | HD Shelf 12"x28"     | 1   |
| 11   | 9          | 4 Drawer Shallow     | 1   |

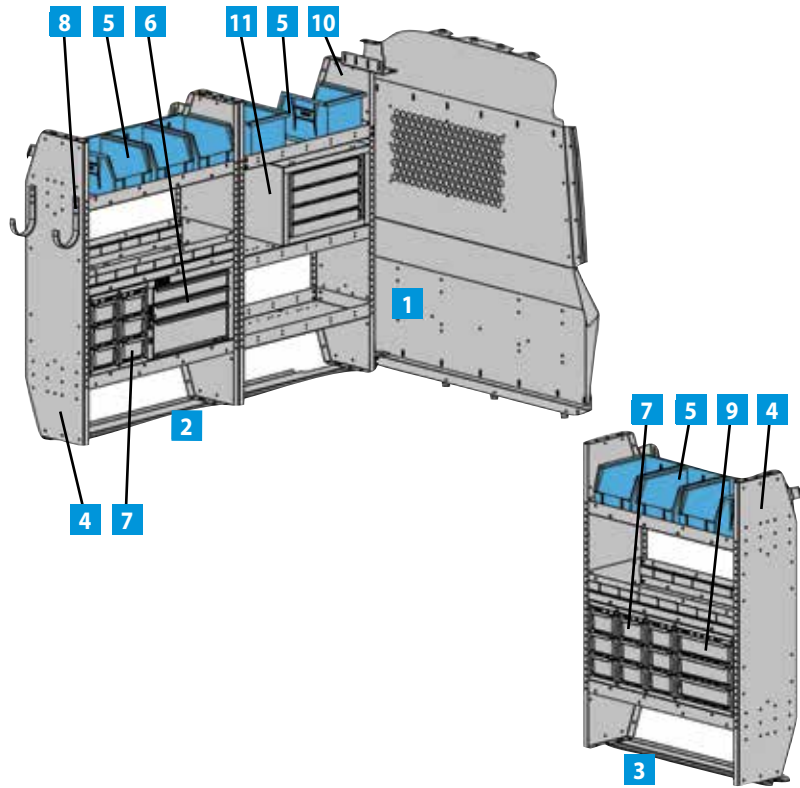

**5083  
ELECTRICAL PACKAGE  
12" HD SERIES SHELVING  
City Express**

| ITEM | MODEL      | DESCRIPTION          | QTY |
|------|------------|----------------------|-----|
| 1    | P2NV2S     | Steel Partition      | 1   |
| 2    | RK67NV2-SS | Rail Kit streetside  | 1   |
| 3    | RKNV2-CS   | Rail Kit curbside    | 1   |
| 4    | HD-32NV2   | HD Shelf 12"x32"     | 2   |
| 5    | TA1        | Four Hook Bar        | 2   |
| 6    | 28         | Blue Bin             | 8   |
| 7    | DC6        | 6" Drawer Component  | 3   |
| 8    | DC12       | 12" Drawer Component | 1   |
| 9    | DV12       | Dividers             | 8   |
| 10   | HD-28NV2   | HD Shelf 12"x28"     | 1   |
| 11   | 919        | 3 Drawer Combo       | 1   |
| 12   | DK532      | Door Kit             | 1   |

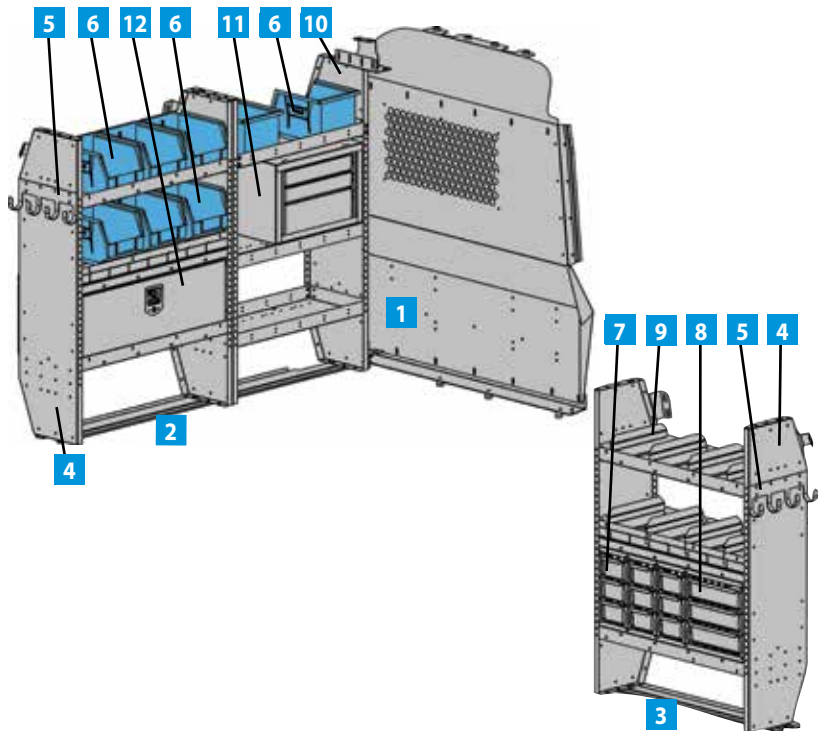



## **Partitions**

|                |   |
|----------------|---|
| Accessories    | 7 |
| City Express   | 7 |
| Express/Savana | 6 |

## **Racks**

|               |    |
|---------------|----|
| Accessories   | 21 |
| Grip-Lock     | 21 |
| Ladder Keeper | 24 |
| LoadsRite     | 20 |
| Perimeter     | 24 |
| Utility       | 23 |

## **Shelving**

|            |    |
|------------|----|
| Adjustable | 9  |
| ADseries   | 8  |
| Welded     | 10 |

## **Trade Packages - City Express**

|               |    |
|---------------|----|
| ADseries      | 37 |
| Base Shelving | 34 |
| HDseries      | 39 |
| Upgrades      | 35 |

## **Trade Packages - Express/Savana**

|                       |    |
|-----------------------|----|
| Alarm/Locksmith       | 30 |
| Auto Glass Repair     | 29 |
| Cable TV              | 28 |
| Electrical Contractor | 29 |
| General Contractor    | 25 |
| General Service       | 26 |
| PHVAC                 | 27 |
| Pro/Access            | 32 |

|                             |    |
|-----------------------------|----|
| Blue Bins                   | 18 |
| Cabinet Modules             | 13 |
| Drawer Units                | 14 |
| Files - Center Console Desk | 16 |
| Files - Literature          | 16 |
| Floor Drawers               | 17 |
| Floor Mats                  | 18 |
| Glass Racks                 | 31 |
| Graphics - CCA              | 4  |
| Liner Kits                  | 33 |
| Lock Box                    | 16 |
| Modules-Storage             | 12 |
| Portable Parts Cases        | 15 |
| Reel Holders                | 19 |
| Tank Racks                  | 18 |
| Van Accessories             | 19 |
| Window Screens              | 19 |
| Workbench Modules           | 12 |

| MODEL      | PAGE | DESCRIPTION              |
|------------|------|--------------------------|
| ACT3       | 19   | Aerosol Can Tray         |
| ACT4       | 19   | Aerosol Can Tray         |
| AD28NV2    | 8    | 28" ADseries             |
| AD32FP     | 8    | 32" ADseries             |
| AD44FP     | 8    | 44" ADseries             |
| AD50FP     | 8    | 50"ADseries              |
| AFD181236  | 17   | Aluminum Floor Drawer    |
| AFD241224  | 17   | Aluminum Floor Drawer    |
| AFD241236  | 17   | Aluminum Floor Drawer    |
| AGSCH2     | 31   | Suction Cup Holder       |
| AGSS24     | 31   | Storage Station          |
| AGTW4      | 31   | Trim Weld Storage        |
| AS12       | 24   | Auxiliary Step           |
| BH4        | 16   | Binder Holder            |
| BR36212    | 18   | Bin System               |
| BR76012    | 18   | Bin System               |
| BRK14EPS   | 8    | End Panel Bracket        |
| BS6VP      | 24   | Light Mount              |
| CB2        | 16   | Two Book File            |
| CB3        | 16   | Three Book File          |
| CB4        | 16   | Utility Storage Box      |
| CB5        | 16   | Literature Holder        |
| CB7        | 16   | Literature Holder        |
| CC17       | 24   | Center Crossbar          |
| CCD12      | 16   | Center Console Desk      |
| CCDHF12    | 16   | 12" Hanging File for CCD |
| CCDLTH     | 16   | Laptop Holder for CCD    |
| CH-EP      | 15   | Case Holder              |
| CHPPC4S    | 15   | Case Holder              |
| CHPPC5SM   | 15   | Parts Case Holder        |
| CH1514SGL  | 15   | Parts Case Shelf Single  |
| CH-1514DBL | 15   | Parts Case Shelf Double  |
| CL1446D    | 13   | Cabinet Locker           |
| CL1446R    | 13   | Cabinet Locker           |
| CRH2       | 19   | Cable Reel Holder        |
| DC6        | 14   | Drawer Component         |
| DC12       | 14   | Drawer Component         |
| DK3008     | 8    | 8" Door Kit              |
| DK3010     | 8    | 10" Door Kit             |
| DK4208     | 8    | 8" Door Kit              |
| DK4210     | 8    | 10" Door Kit             |
| DK4808     | 8    | 8" Door Kit              |
| DK4810     | 8    | 10" Door Kit             |
| DK532      | 8,11 | 32" Door Kit             |
| DK544      | 11   | Door Kit                 |
| DK550      | 11   | Door Kit                 |
| DS06212V   | 14   | Drawer System            |
| DS36012H   | 14   | Drawer System            |
| DS46012    | 14   | Drawer System            |
| DST21      | 19   | Door Storage Tray        |
| DT21       | 19   | Door Tray                |
| DTL21      | 19   | Door Tray Lid            |
| DTWL21     | 19   | Door Tray w/Lid          |
| DV19       | 17   | Divider/Stow-All         |
| DV14C1     | 8    | Divider/Single           |
| DV14C8     | 8    | Divider/8 Pack           |
| DVJ9       | 17   | Divider/Stow-All         |
| DVJ19      | 17   | Divider/Stow-All         |
| DV9        | 17   | Divider/Stow-All         |
| DV44U      | 11   | Divider/8 pack           |
| DV44U1     | 11   | Divider/upper            |
| DV44U4     | 11   | Divider/4 pack           |
| DV44L1     | 11   | Divider/lower            |
| DV44L4     | 11   | Divider/4 pack           |

| MODEL      | PAGE | DESCRIPTION                  |
|------------|------|------------------------------|
| HD-32FP    | 9    | 32" Shelf Unit               |
| HD-42FP    | 9    | 42" Shelf Unit               |
| HD-52FP    | 9    | 52" Shelf Unit               |
| JD42FP     | 9    | 42" Shelf Unit               |
| JD52FP     | 9    | 52" Shelf Unit               |
| JD48FP     | 9    | 48" Shelf Unit               |
| JD60FP     | 9    | 60" Shelf Unit               |
| KDRH1426   | 19   | End Panel Reel Holder        |
| KDRH1432   | 19   | End Panel Reel Holder        |
| KDRH1444   | 19   | End Panel Reel Holder        |
| KDRH1450   | 19   | End Panel Reel Holder        |
| KDRH2      | 19   | Reel Holder                  |
| KMB18      | 30   | 18" Key Machine Base         |
| KMB36      | 30   | 36" Key Machine Base         |
| LK8        | 30   | Ladder Keeper                |
| LKB1       | 16   | Aluminum Lock Box            |
| LKX        | 20   | Ladder Keeper Ext            |
| LR6100WCF  | 20   | LoadsRite/Single-curbiside   |
| LR6100WSF  | 20   | LoadsRite/Single-streetside  |
| LR6200WCF  | 20   | LoadsRite Add-on Kit - CS    |
| LR6200WSF  | 20   | LoadsRite Add-on Kit - SS    |
| LR6300WF   | 20   | Double LoadsRite             |
| LR6400WCF  | 20   | Combo LoadsRite - CS         |
| LR6400WSF  | 20   | Combo LoadsRite - SS         |
| LRSLK612   | 20   | Step Ladder Kit              |
| LS3VP      | 24   | Ladder Stop                  |
| MD506      | 12   | Module, Drawer Cabinet       |
| MD507      | 12   | Module, Drawer Rack          |
| MD508      | 12   | Module, Workbench            |
| MD509      | 12   | Module, Workbench            |
| MD534      | 12   | Module, Drawer Rack          |
| MD608      | 12   | Module, Workbench            |
| PA5-1      | 7    | Plexiglas Panel              |
| PA5-2      | 7    | Plexiglas Panel              |
| PA5-3GMS   | 7    | Plexiglas Kit                |
| PA5-6GMS   | 7    | Plexiglas Kit                |
| PA7        | 7    | Reflector Flare Kit          |
| PA8        | 7    | Fire Extinguisher            |
| PA9        | 7    | First Aid Tray               |
| PA10       | 7    | Practice Holder              |
| PDK1       | 7    | Partition Door Kit           |
| PPCS       | 15   | Portable Parts Case          |
| PPCL       | 15   | Portable Parts Case          |
| P2NV2FW    | 7    | Wire Partition-City Express  |
| P2NV2S     | 7    | Steel Partition-City Express |
| RKA1       | 8    | Rail Kit Adapter             |
| RKA3       | 8    | Rail Kit Adapter             |
| RKA4       | 8    | Rail Kit Adapter             |
| RKABRK1    | 8    | Rail Kit Adapter             |
| RKABRK2    | 8    | Rail Kit Adapter             |
| RKAWTR     | 8    | Rail Kit Adapter             |
| RKA919     | 8    | Rail Kit Adapter             |
| RKFSVLWB   | 8    | Rail System                  |
| RKFSVXLWB  | 8    | Rail System                  |
| RKNV2-CS   | 8    | Rail Kit-City Express        |
| RKNV2-SS   | 8    | Rail Kit-City Express        |
| RK67NV2-CS | 8    | Rail Kit-City Express        |
| RK67NV2-SS | 8    | Rail Kit-City Express        |
| RR5        | 24   | Cargo Rack Roller            |
| RS4        | 24   | Ratchet Strap                |
| S1M1C1FSV  | 6    | Partition FSV                |
| S1M1HC1FSV | 6    | Partition FSV                |
| S1M2C1FSV  | 6    | Partition FSV                |
| S1M2HC1FSV | 6    | Partition FSV                |

| MODEL      | PAGE | DESCRIPTION             |
|------------|------|-------------------------|
| S1M2C2FSV  | 6    | Partition FSV           |
| S1M2HC2FSV | 6    | Partition FSV           |
| S2M2C2FSV  | 6    | Partition FSV           |
| S2M2HC2FSV | 6    | Partition FSV           |
| SA-10      | 17   | Stow-All/Single/Deep    |
| SA-20      | 17   | Stow-All/Double/Deep    |
| SA-40      | 17   | Stow-All/Quad/Deep      |
| SAJ-10     | 17   | Stow-All/Sgl/Shallow    |
| SAJ-20     | 17   | Stow-All/Db/ Shallow    |
| SAJ-30     | 17   | Stow-All/Triple/Shallow |
| SAJ-40     | 17   | Stow-All/Quad/Shallow   |
| SBIN060614 | 18   | 6" Plastic Bin          |
| SBIN120614 | 18   | 12" Plastic Bin         |
| SBINDIV    | 18   | Plastic Bin Divider     |
| SF11218DC  | 11   | DC Unit Shelf           |
| SF11224DC  | 11   | DC Unit Shelf           |
| SF11236DC  | 11   | DC Unit Shelf           |
| SH12       | 24   | Step Handle             |
| SPT-4      | 14   | SP Tote/Combo           |
| SPT-4P     | 14   | SP Tote/Poly            |
| SPT-4S     | 14   | SP Tote/Steel           |
| SPT-5      | 14   | SPT Steel Tray          |
| SPT-P      | 14   | SPT Poly Tote           |
| SRAILAD26  | 18   | Bin Retention Rail 26"  |
| SRAILAD32  | 18   | Bin Retention Rail 32"  |
| SRAILAD44  | 18   | Bin Retention Rail 44"  |
| SRAILAD50  | 18   | Bin Retention Rail 50"  |
| SSK-BS     | 23   | Side Stop Kit           |
| SSK-BA     | 23   | Side Stop Kit           |
| SSK-WA     | 23   | Side Stop Kit           |
| SSK-WS     | 23   | Side Stop Kit           |
| STP12G     | 19   | Paint, Gray             |
| STP12W     | 19   | Paint, White            |
| STP12B     | 19   | Paint, Black            |
| TA1        | 7,19 | Hook Bar                |
| TA2        | 19   | Hard Hat Holder         |
| TA18       | 13   | Propane Tank Cab.       |
| TA19       | 13   | CO2 Tank Cabinet        |
| TA20       | 13   | Mapp Gas Cabinet        |
| TH30       | 7    | Freon Tank Holder       |
| TH50       | 7    | Freon Tank Holder       |
| TK10       | 17   | Traction Kit            |
| TK20       | 17   | Traction Kit            |
| TK30       | 17   | Traction Kit            |
| TK40       | 17   | Traction Kit            |
| UH10       | 19   | Utility Hook            |
| UH25       | 19   | Utility Hook            |
| UH50       | 19   | Utility Hook            |
| VMA36      | 19   | Vise Mount Assm.        |
| VP1        | 24   | Perimeter Rack          |
| VPE1       | 24   | Perimeter Rack Ext      |
| WKC1FSVGM  | 6    | Wing Kit                |
| WKC1FSVGM3 | 6    | Wing Kit 3"             |
| WKC2FSVGM  | 6    | Wing Kit                |
| WKC2FSVGM3 | 6    | Wing Kit 3"             |
| WKX1FSVGM  | 6    | Wing Kit                |
| WKX1FSVGM3 | 6    | Wing Kit 3"             |
| WRH5       | 19   | Wire Reel Holder        |
| WTR130250  | 18   | Tank Rack               |
| WTR230150  | 18   | Tank Rack               |
| WTR330     | 18   | Tank Rack               |
| WTR350     | 18   | Tank Rack               |
| WTR430     | 18   | Tank Rack               |
| WTRTRAY    | 18   | Top Tray                |

| MODEL  | PAGE | DESCRIPTION                 |
|--------|------|-----------------------------|
| X1FSV  | 6    | Partition                   |
| 1      | 13   | Cabinet                     |
| 1A     | 13   | Shelf                       |
| 1BAR-B | 23   | Crossbar/Black              |
| 1BAR-W | 23   | Crossbar/White              |
| 1BRS-B | 23   | Crossbar/Black              |
| 1BRS-W | 23   | Crossbar/White              |
| 2      | 14   | Drawer Unit                 |
| 2BAR-B | 23   | Utility Rack/Black          |
| 2BAR-W | 23   | Utility Rack/White          |
| 2BNV2  | 23   | Utility Rack-City Express   |
| 2BRS-B | 23   | Utility Rack/Black          |
| 2BRS-W | 23   | Utility Rack/White          |
| 3      | 9    | KD Shelf Rack               |
| 4A     | 19   | Parts Tray                  |
| 4B     | 19   | Parts Tray                  |
| 8      | 14   | Drawer Unit                 |
| 9      | 14   | Drawer Unit                 |
| 12     | 13   | Cabinet                     |
| 12A    | 13   | End Panel                   |
| 14     | 19   | Step Stool                  |
| 17A    | 16   | Catalog File                |
| 18     | 10   | Utility Shelf               |
| 19     | 14   | Drawer Unit                 |
| 25     | 14   | Divider/#2                  |
| 26     | 14   | Divider/#8                  |
| 27     | 14   | Divider/#19                 |
| 28     | 11   | Plastic Blue Bin            |
| 33     | 9    | KD Shelf Rack               |
| 33W    | 9    | Shelf Rack                  |
| 33WB   | 9    | Shelf Rack w/bins           |
| 43     | 16   | Catalog File                |
| 60-21  | 19   | Window Screen               |
| 60-22  | 19   | Window Screen               |
| 60-23  | 19   | Window Screen               |
| 60-24  | 19   | Window Screen               |
| 60-25  | 19   | Window Screen               |
| 60-26  | 19   | Window Screen               |
| 60-120 | 19   | Window Screen-City Express  |
| 60-121 | 19   | Window Screen-City Express  |
| 60-NV2 | 19   | Window Screen-City Express  |
| 61-1   | 22   | Grip-Lock Rack              |
| 61-NV2 | 22   | Grip-Lock Rack-City Express |
| 63-NV2 | 22   | Grip-Lock Rack-City Express |
| 63-1   | 22   | Grip-Lock Rack              |
| 64-1   | 22   | Grip-Lock Rack              |
| 68-3   | 22   | Step Ladder Kit             |
| 69-4   | 22   | Rack Extension Kit          |
| 70-1   | 22   | Conduit Kit                 |
| 70-2   | 22   | Conduit Kit                 |
| 71     | 28   | Tie Down Kit                |
| 76     | 22   | Rail Cover Kit              |

| MODEL   | PAGE  | DESCRIPTION                   |
|---------|-------|-------------------------------|
| 80-1    | 22,24 | Conduit Carrier               |
| 80-2    | 22,24 | Conduit Carrier               |
| 88-2    | 18    | Workmat                       |
| 88-9    | 18    | Workmat                       |
| 919     | 14    | Drawer Unit                   |
| 2251G   | 27    | PHVAC Pkg                     |
| 2252G   | 29    | Elect. Pkg                    |
| 2253G   | 30    | Alarm Pkg                     |
| 2255G   | 30    | Locksmith Pkg                 |
| 2256G   | 25    | Gen. Contr. Pkg               |
| 2257G   | 25    | Gen. Contr. Pkg               |
| 2258G   | 28    | Cable Pkg                     |
| 2261G   | 27    | PHVAC Pkg                     |
| 2262G   | 29    | Elect. Pkg                    |
| 2940G   | 32    | Access/Pro Pkg                |
| 2941G   | 32    | Access/Pro Pkg                |
| 2942G   | 32    | Access/Pro Pkg                |
| 3056G   | 34    | Protecto-Van Liner            |
| 3057G   | 34    | Protecto-Van Liner            |
| 3230G   | 28    | Cable Pkg.                    |
| 35325-G | 8     | 32" Shelf ADseries            |
| 35327-G | 8     | 44" Shelf ADseries            |
| 35328-G | 8     | 50" Shelf ADseries            |
| 4135G   | 26    | 44 Series Pkg                 |
| 4136G   | 26    | 44 Series Pkg                 |
| 4138G   | 26    | 44 Series Pkg                 |
| 4145G   | 31    | Auto Glass Pkg                |
| 4317G   | 25    | Gen Svc Pkg GM                |
| 4317GX  | 25    | Gen Svc Pkg GM                |
| 4318G   | 27    | PHVAC Pkg GM                  |
| 4318GX  | 27    | PHVAC Pkg GM                  |
| 4319G   | 29    | Electrical Pkg GM             |
| 4319GX  | 29    | Electrical Pkg GM             |
| 4432    | 11    | 32" Welded Cabinet            |
| 4442    | 11    | 42" Welded Cabinet            |
| 4450    | 11    | 50" Welded Cabinet            |
| 45047   | 31    | Burco Glass Rack              |
| 4959    | 34    | Base Pkg 1 - City Express     |
| 4960    | 34    | Base Pkg 2 - City Express     |
| 4961    | 34    | Base Pkg 3 - City Express     |
| 4962    | 34    | Base Pkg 4 - City Express     |
| 4964    | 35    | Upgrade Pkg 1 - City Express  |
| 4965    | 35    | Upgrade Pkg 2 - City Express  |
| 4966    | 36    | Upgrade Pkg 3 - City Express  |
| 4967    | 36    | Upgrade Pkg 4 - City Express  |
| 5080    | 40    | Plumbing Pkg - City Express   |
| 5081    | 39    | Telcom Pkg - City Express     |
| 5082    | 39    | Shelving Pkg - City Express   |
| 5083    | 40    | Electrical Pkg - City Express |
| 5084    | 39    | Gen Svc Pkg - City Express    |
| 5096    | 38    | Plumbing Pkg - City Express   |
| 5097    | 37    | Telcom Pkg - City Express     |

|        |    |                               |
|--------|----|-------------------------------|
| 5098   | 37 | Shelving Pkg - City Express   |
| 5099   | 38 | Electrical Pkg - City Express |
| 5100   | 37 | Gen Svc Pkg - City Express    |
| 5384G  | 34 | Liner Package                 |
| 5384GX | 34 | Liner Package                 |

# ADRIAN STEEL COMPANY



## QUALITY

- Our products are durable and reliable. Warranty claims are less than 1% of sales.
- Our warranty covers our products for three years or 36,000 miles.

## INNOVATIVE PRODUCTS WITH FEATURES THAT MATTER

- Drawers that stay closed while in transit.
- ADseries truly adjustable shelving platform.
- LoadsRite and Grip-Lock ladder racks that load and unload the safe and right way.
- Interior ladder storage.
- Plug and Play accessories.
- Anti-slam drawer latches, and much more!



## COMMITMENT

At Adrian Steel, we are committed to you beyond the upfit!

- A dedicated Customer Care Team at corporate headquarters.
- A network of highly qualified distributors to support you locally.
- Our commitment to provide the best cargo management solutions in North America.

## EXPERIENCE

- **Over One Million vans upfitted**, and counting! It's a fact that an organized vehicle increases work flow efficiencies and reduces inventory damages.
- Recognized as a National Truck Equipment Association MVP.



## SERVICE

- Adrian Steel Products can be purchased throughout North America at authorized Adrian Steel distributors.
- Adrian Steel Customer Service Representatives are available M-F, 8am - 5pm EST at **1-800-677-2726**.
- E-mail us at [info@adriansteel.com](mailto:info@adriansteel.com) with questions, comments and feedback.
- Visit [AdrianSteel.com](http://AdrianSteel.com) for the most up-to-date product information, distributor locator, product catalogs, videos and more.

## PROUDLY DISTRIBUTED BY:



906 James Street  
Adrian, Michigan 49221-3996  
517-265-6194 Fax: 517-265-5834  
Toll Free **800-677-2726**  
[adriansteel.com](http://adriansteel.com) [info@adriansteel.com](mailto:info@adriansteel.com)